

CATALOG &
TECHNICAL
GUIDE 2019.1



HOLEMAKING

> 30,000

STANDARD PRODUCTS



> 75

COUNTRIES



> 4,100

DEDICATED EMPLOYEES



Headquartered in Fagersta, Sweden and present in more than 75 countries, Seco Tools is a leading global provider of metal cutting solutions for milling, stationary tools, holemaking and tooling systems.

For more than 80 years, the company has provided the technologies, processes and support that manufacturers depend on for maximum productivity and profitability. For more information on how Seco's innovative products and expert services bring success to manufacturers across all industry segments, please visit www.secotools.com.

WELCOME TO SECO HOLEMAKING



Alphanumeric index	5-7
Guidelines	8-14
ISO Attribute information	15
Solid Carbide Drills	Range overview and technical information.....	16-26
Seco Universal / Seco Feedmax™	27-88
	Guidelines and cutting data.....	89-114
Crownloc®	Range overview and technical information.....	115-118
	Crownloc® - tools and crowns.....	119-126
	Guidelines and cutting data.....	127-138
Crownloc®Plus	Range overview and technical information.....	139-142
	Crownloc®Plus - tools and crowns.....	143-151
	Guidelines and cutting data.....	152-157
Performax®	Range overview and technical information.....	158-164
	Performax® - tools.....	165-191
	Inserts, guidelines and cutting data.....	192-225
Holders for drills	Range overview.....	226
	Holders.....	227-228
Seco Reaming	Range overview.....	229-231
Precimaster™Plus	Range overview and technical information.....	232-242
	Precimaster™Plus - heads and shanks.....	243-257
	Cutting data.....	251-253
	Guidelines.....	258-260
Nanofix™	Range overview and technical information.....	261-267
	Nanofix™ - reamers and toolholders.....	268-276
	Guidelines and cutting data.....	277-281
Bifix®	Range overview and technical information.....	282-286
	Bifix® - heads, shanks and blades.....	287-293
	Guidelines, inserts and cutting data.....	294-302
Precifix™	Range overview and technical information.....	303-307
	Precifix™ - heads, shanks and blades.....	308-319
	Guidelines, inserts and cutting data.....	320-324

Xfix™	Range overview and technical information.....	325-330
	Xfix™ - heads and shanks.....	331-354
	Guidelines and cutting data.....	355-361
Holders for reamers	Overview.....	362-363
Adjustable holders	Adjustable holders.....	364-371
	Guidelines.....	372-373
Floating holder	Range overview.....	374
	Floating holders.....	375-379
Setting fixture	380-385
Boring heads	Range overview and technical information.....	386-392
Rough boring heads, EPB 750	Heads / Holders.....	393-399
	Instructions / Assembly and operation.....	400-401
Rough boring heads, EPB 610	Range overview and technical information.....	402-404
	Heads / Holders.....	405-408
	Instructions / Assembly and operation.....	409
Fine boring heads, Axiabore™	Range overview and technical information.....	410-416
	Heads / Tools / Holders.....	417-434
	Instructions / Assembly and operation.....	435-436
Fine boring heads, radial type	Range overview and technical information.....	437-441
	Heads / Holders.....	442-449
	Instructions / Assembly and operation.....	450
Bridge bar boring heads	Range overview and technical information.....	451-462
	Holders and Adapters / Bars / Blocks / Cartridges.....	463-467
	Instructions / Assembly and operation.....	468
Custom boring solutions	469
Inserts for boring	Code key / Grades / Guidelines.....	470-473
	Inserts / Cutting data.....	474-478
	Insert locking accessories and spare parts.....	479

Drilling

Reaming

Boring heads

Holemaking
tolerances

SMG

Declaration of
conformity

Boring heads, Graflex or Seco-Capto connections	Connection locking advice and spare parts	480-482
Holemaking tolerances	483-489
SMG	Workpiecematerials SMG*	490-501
Declaration of conformity	502-504

A	
A610	405, 408
A724	447
A725	447
A726	447
A729	448
A731	463-466
A750	393, 395-399
A760	408, 417-418, 422
A761	420
A762	421
A763	421
A765	421, 423
A780	442
A782	447
A789	449
A790	444
AFG0629	428
B	
BAS25	426-427
BDA16	425
BM	227-228
BM*6100	227
BM*6101	228
BMA	191
BMH	191
C	
C.-390.140	335, 341, 347
C.-390.272	347, 353
C.-390.369	335
C.-390.410	335, 341, 347, 353
C.-390.540	335, 341, 353
C.-390.55	335
C.-390.555	335
C.-390.558	341
C.-390.58	335, 341
C.-391.01	335, 341, 347, 353
C.-391.02	335, 341
C3-390.140	335
C3-390.272	335
C3-390.369	335
C3-390.540	335
C3-390.55	335
C3-390.58	335
C3-391.0750	394
C3-391.0760	419
C3-391.0780	443
C4-391.0750	394
C4-391.0780	443
C5-390.140	341
C5-390.272	341
C5-390.369	341
C5-390.540	341
C5-390.55	341
C5-390.555	341
C5-390.58	341
C5-391.0750	394
C5-391.0760	419
C5-391.0780	443
C6-390.140	347
C6-390.272	347
C6-390.369	347
C6-390.540	347
C6-390.55	347
C6-390.555	347
C6-390.558	347
C6-390.58	347
C6-391.0750	394
C6-391.0780	443
C8-390.140	353
C8-390.272	353
C8-390.369	353
C8-390.558	353
C8-390.58	353
C8-391.02	335, 341
C8-391.0750	394
C8-391.0780	443
CPGT	474
E	
E3416731200	463
E3471731200	463
E9306731200	463
EM*3414	336, 342, 348
EM*3416	336, 342, 348, 354
EM*3469	336, 342, 348
EM*3471	336, 342, 348, 354
EM*9304	336, 342, 348
EM*9306	336, 342, 348, 354
EM4468	348
EM9306	354
G	
GL32	406, 445
GL40	406, 445
GL50	406, 445
H	
HF100	353-354
HF32	335-336
HF55	341-342
HF80	347-348
HF85	331, 337, 343, 349
HF85B	332, 338, 344, 350
HF86	333, 339, 345, 351
HF86B	334, 340, 346, 352
M	
M402	336, 342, 348, 354
N	
NF06	268-269, 271
NF10	269-271
NFQF	276
NS06	272-273, 275
NS10	273-275

P

PCGNR/L16CA	467
PF84	308, 310, 312, 314, 316, 318
PM07	309
PM08	311
PM11	313
PM15	315
PM19	317
PMX05	245
PMX06	245, 247-250
PMX06B-16B	246
PMX08	245, 248-250
PMX12	245, 247-250
PMX16	245, 247-250
PMX5	243, 256
PMX6	244, 254
PMX8	257

SSRCL	467
STGCR/L..CA	467
STRCR/L..CA	467
STSCR/L..CA	467
STTCR/L..CA	467

S

SAH	365-371
SCGL	467
SD100	126
SD101	119, 129
SD103	120, 130
SD105	121, 131
SD107	122, 132
SD1103	27-30, 101
SD1103A	31-34
SD1105A	35-39
SD110XA	101
SD200	61
SD203	75, 111
SD203A	40-44, 59-60, 64-65, 68, 70, 76, 102-103, 111
SD205	77
SD205A	45-50, 66-67, 69, 73-74, 104-105, 111
SD206	51, 107
SD206A	52, 107
SD207A	53-54, 106
SD216A	55, 108
SD22	79-83
SD230A	56, 109
SD245A	57, 109
SD26	84-88
SD265A	58, 110
SD2X	112-114
SD400	149
SD403	143-144, 152
SD405	145-146, 153
SD408	147-148, 154
SD522	165-167, 203-204
SD523	168-174, 205-206
SD524	175-180, 207-208
SD525	181, 209-210
SD542	182, 211-212
SD572	183-184, 213-214
SD602	189, 215-216
SF	360, 380-382
SFH	375-379
SR80	287-289
SR81	290-292
SR82	293

C

CCGT	474, 476
CCGW	476
CCMT	474, 476
CCMW	476
CNMG	475

L

LNEG	319, 321, 329, 356-357
------------	------------------------

P

P0	295
P00	295
P1	295
P2	295
P4	295

R

RNAX	319, 321, 329, 357
------------	--------------------

S

SCGX	196-198
SCMT	474
SD100	123-125
SD400	150-151
SPGX	196, 199-200

T

TCGT	474, 476
TCGW	476
TCMT	474, 476
TCMW	476

W

WCMX	201-202
------------	---------

At Seco we make every effort to give you the best in drilling, reaming, threading and boring. Our comprehensive range of holemaking tools are second-to-none.

We have years of experience of 'challenging' holemaking applications. Our R&D and metal cutting expertise consistently yields new and more productive solutions. But most importantly, we pride ourselves on offering the highest service level, and on being engaged in making our customers as cost-effective and competitive as possible.

Seco Tools will take responsibility and assist in all areas to create the hole, including technical troubleshooting.

We supply complete holemaking know-how, including drilling, reaming, threading and boring – finding ways and processes making you more competitive. And we offer great simplicity by streamlining administration, support and service through one contact. The result?

You don't need to worry about holemaking we take care of the complete process.

As a Seco customer, you are offered:

- One stop shopping of high quality metal cutting tools, solutions and services
- Simplicity of contacts, purchasing, stock, technical support, consultancy and process solutions
- A range of high performance holemaking tools covering drilling, reaming, threading and boring
- One supplier responsible for the quality of the finished hole - or even for the complete machining of the finished part
- Complete holemaking know-how, including drilling, reaming, threading and boring
- Greatly increased process security with close cooperation together with one knowledgeable supplier
- The highest tool quality offering great productivity and cost reduction opportunities



What are you looking for in making a hole?

	Drilling			Threading				Boring		Reaming		
	Seco Feedmax™ Seco Universal	Crownloc® Crownloc® Plus	Performax®	Threadmaster™	Threadmaster™ Taps		Thread milling 396.18/396.19	EPB 750, EPB 610 Rough boring	EPB 760, EPB 780, EPB 790, EPB 620 Fine boring	Precimaster™ Plus/ Nanofix™	Bifix®/ Precifix™	Xfix™
Page(s)	16-114	115-157	158-225	See MN Threading catalogue				389-409, 451-468	410-449	232-281	282-324	325-361
IT	7-9	9-10	12					9-10	5-6	6-8	6-7	6-7
	0,02	0,05	-		Follow the pre-bore	Follow the pre-bore		0,005	0,005	Follow the pre-bore	Follow the pre-bore	Follow the pre-bore
	0,02	0,05	-					0,02	0,01	0,007	0,005	0,005
	1,0	1,6	2,0					1,0	0,6	0,6	0,25	0,6
TCTR	-	-	-		6H 6HX 6G 2B Normal	5HX 2BX Normal-X 6HX 6GX		-	-	-	-	-
Thread form	-	-	-	M MF UNC UNF NPT NPTF BSP	M MF UNC UNF G NPT NPTF	M MF UNC UNF G	ISO UN W NPT NPTF BSPT	-	-	-	-	-



Positioning accuracy

Seco Feedmax, A750 rough boring heads and the whole range of fine boring heads are the holemaking tools that offer the best positioning accuracy.



Hole geometry

For excellent hole geometry, such as as roundness and straightness, all of Seco's drilling, boring and reaming tools offer the same high and consistent quality. Seco's boring heads will always guarantee the best results on straightness.



Surface finish

For a really smooth hole surface Bifix/Precifix is your first choice, and Seco's fine boring heads offer a full range of machining capabilities.

TCTR = Thread Tolerance Class

IT = Hole tolerance

TOOL GUIDE

Drilling

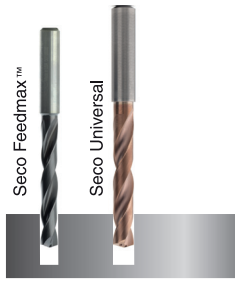

Ø 0,1-20 mm
IT 7/9

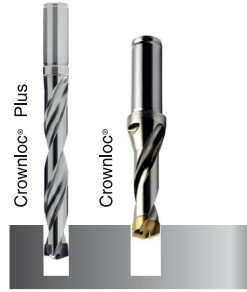

Ø 10-26 mm
IT 9/10

Boring

EPB 760
EPB 780
EPB 790
EPB 620



Reaming

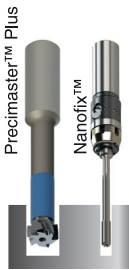

Ø 3-40 mm
IT 6/8



Ø 6-135 mm
IT 6/7



Threading

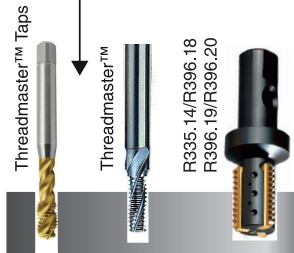

M1-M64
6G, 6H

M1-M20

12 - <

TOOL GUIDE

Cast holes

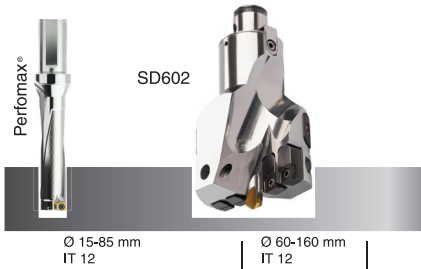

Ø 15-85 mm
IT 12

Ø 60-160 mm
IT 12



Ø 18-205 mm
IT 9/10

Rough boring

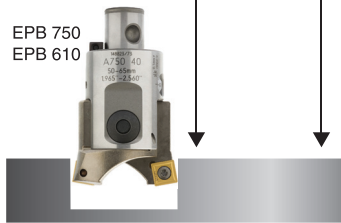

Ø 18-205 mm
IT 9/10

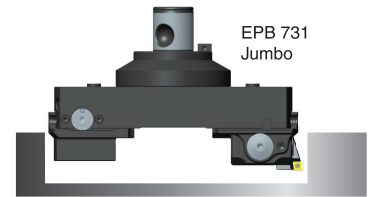

Ø 204-3205 mm
* IT 9/10
** IT 5/6

Fine boring



Ø 0,3-205 mm
IT 5/6

Seco Feedmax, Crownloc and Performax are used to drill holes from 0,1 to 160 mm in diameter, with tolerances from IT8 to IT12.

For already cast holes, rough boring or semi-finishing is often used, with Bridge Bars and Jumbo Bridge Bars used for the large diameters.

Finally, high quality holes are made with reaming and fine boring heads, reaching tolerances of IT5 or IT6.

* Rough IT9/10, ** Fine IT 5/6

Threadmaster DTM, TM, TM2, 396.18 and 396.19; The same cutter could be used for machining right and left hand threads. Metric and UN versions are only for internal threading. It's also possible to make all types of tolerances with the same cutter.

Threadmaster Tap: Available in the most popular threads and tolerances in both cutting and forming taps.

Drilling at Seco

- Seco can offer one stop shopping of high quality drills, solutions and services
- We have years of experience in 'challenging' drill applications
- Seco has a full range of drill products that fits all applications and materials in all industry segments, like Automotive, Aerospace, Energy, Medical etc.
- The wide diameter range of Seco drills from 0,1 – 160 mm with the Feedmax™ (solid carbide drills), Crownloc® (exchangeable tip drills) and Perfomax® (Indexable drills), covers the most common thread sizes in the market
- More information about the drill products can be found at, www.secotools.com

Threading at Seco

- Seco can now offer all types of threading methods
- For many years Seco have been the market leader in thread turning with the well known Snap-Tap® products
- During the last ten years Seco has been established as a leading supplier of tools for thread milling, with the solid Threadmaster™ and Drilling Threadmaster as well as 396.19 with indexable carbide inserts
- Seco is also supplier of chasers for the Oil & Gas industry
- Seco is also supplying threading taps which makes Seco's product offering for threading tools complete
- All threading products are supported by the 'Threading Wizard' machining guidance software, available from www.secotools.com

Thread tapping

- Available as both cutting and forming taps
- An easy, well known and productive threading process
- Can be used for both rotating and non-rotating applications
- Good chip control
- Easy to thread in deep holes



Drilling range – Choice of drill

Seco Feedmax™ Solid carbide drills



PRODUCTIVITY

- High feeds and cutting speeds
- Close tolerance holes
- For applications with high stability
- For all workpiece materials

Crownloc® & Crownloc®Plus Exchangeable crown drills



FLEXIBILITY

- Exchangeable carbide tips
- Geometries for different workpiece materials
- No regrinding
- Several tip diameters for each drill body

Perfomax® Indexable insert drills



COST EFFECTIVENESS

- Grades and geometries for all workpiece materials
- Square inserts for low cost/hole
- Drilling, plunging, crossing holes with angled entrance or exit, boring, etc.
- High application security

SMG – Introduction

The foundation for SMG is a classification of workpiece materials based on their type rather than their relative machinability and consequently it contains workpiece materials like composites. It is comprehensive enough, but still easy to identify to which SMG a particular material belongs. Each SMG has a specific material standard in a specific condition assigned as reference to allow easy adjustment of cutting data for any actual material compared to any Seco reference material see pages 490 - 493.

As example the reference materials EN C45E for SMG P4 and EN 42 CrMo 4 for both SMG P5 and SMG H5 see further details in the following tables.

In SMG classification of workpiece materials involves a specific material standard in a specific condition assigned as reference for easy and unambiguous adjustment of cutting data for any actual material compared to any Seco reference material. As examples the reference materials EN C45E for SMG P4 and EN 42 CrMo 4 for both SMG P5 and SMG H5 shown below in table 1 where the reference level material property is indicated.

SMG	Description	Properties	Reference	SMG	Description	Properties	Reference
P4	Low-alloy general structural steels, 0.25% < C < 0.67%wt Low-alloy Quench & Temper steels	520 < R _m < 1200	C 45E R _m = 660 N/mm ²	H5	Quenched & Tempered steels	38 < HRC < 56	42 CrMo 4 50 HRC
P5	Structural steels, 0.25% < C < 0.67%wt Quench & Temper steels	550 < R _m < 1200	42 CrMo 4 R _m = 700 N/mm ²				

Focusing specifically on EN 42 CrMo 4 in annealed condition, the ultimate tensile strength R_m may typically vary between R_m = 630 N/mm² and R_m = 780 N/mm², which provide a reference level for SMG P5. In Quenched & Tempered condition, the ultimate tensile strength R_m may typically be between R_m = 900 N/mm² and R_m = 1100 N/mm² thus still belongs to SMG P5. However, if hardened above R_m = 1200 N/mm² it now belongs to SMG H5.

SMG	EN	W.-Nr	AFNOR	BS	UNI	JIS	AISI / ASTM	GOST	Condition	R _{m, nom}	HRC _{nom}
P5	42 CrMo 4	1.1201	42 CD 4	708 M 40	42 CrMo 4	SCM 440 (H)	4142, 4140	38HM	Annealed	700	
	42 CrMo 4	1.1201	42 CD 4	708 M 40	42 CrMo 4	SCM 440 (H)	4142, 4140	38HM	Quenched & Tempered	1000	
H5	42 CrMo 4	1.1201	42 CD 4	708 M 40	42 CrMo 4	SCM 440 (H)	4142, 4140	38HM	Quenched & Tempered		45
	42 CrMo 4	1.1201	42 CD 4	708 M 40	42 CrMo 4	SCM 440 (H)	4142, 4140	38HM	Quenched & Tempered		50

The EN 42CrMo4 quench & tempered steel could be used to illustrate the machinability dependence of materials' condition.

The graphs below indicate how speed recommendations for a nominal material conditions may be adjusted for relative R_m (left diagram valid for ISO-P) and for relative HRC (valid for ISO-H).

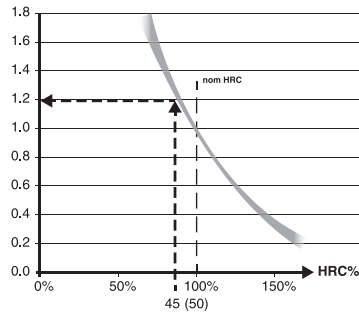
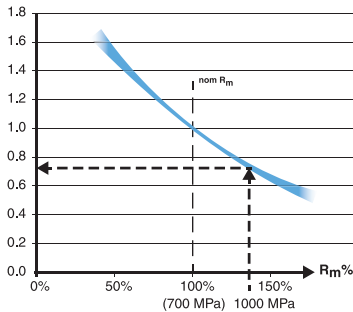

To further illustrate how the SMG P5 nominal v_c can be adjusted to a more accurate recommended v_c we need ultimate tensile strength R_m data and in this case we use the EN 42 CrMo 4 quenched & tempered to R_m = 1000 N/mm² according to above table (bold blue arrows).

Assume that we find that the SMG P5 nominal v_c = 280 m/min for a certain product and machining.

Then, actual recommended v_c = 280 m/min × 0,75 = 210 m/min.

Consequently in the SMG H5 the nominal v_c can be adjusted using the hardened EN 42 CrMo 4 at HRC 45 (smaller grey arrows).

Assume that the SMG H5 nominal v_c = 50 m/min for a certain product and machining using a coated cemented carbide tool then, actual recommended v_c = 50 m/min × 1,2 = 60 m/min.

For further workpiece material details please see page(s) 494-501 and suggested cutting data at applicable pages.

For more convenient cutting data handling we recommend applicable tools in My Pages – Suggest on www.secotools.com

ISO attribute	Explanation
ADJLN	Minimum adjustment limit
ADJLX	Maximum adjustment limit
ADJRG	Adjustment range
AN	Clearance angle major
APMX	Depth of cut maximum
AZ	Maximum plunge depth
B	Shank width
BD	Body diameter
BDX	Body diameter maximum
BLQ	Balance quality code
BN	Face land width
CBDP	Connection bore depth
CDX	Cutting depth maximum
CEDC	Cutting edge count
CHA	Cross hole angle
CHW	Corner chamfer width
CNT	Coolant entry thread size
CW	Cutting width
CZC	Connection size code
D1	Fixing hole diameter
DC	Cutting diameter
DCB	Connection bore diameter
DCBN	Connection bore diameter minimum
DCBX	Connection bore diameter maximum
DCB1	Connection bore diameter 1
DCC	Design configuration style code
DCINN	Minimum cutting diameter internal
DCINX	Maximum cutting diameter internal
DCN	Minimum cutting diameter
DCON	Connection diameter
DCX	Maximum cutting diameter
DF	Flange diameter
DMM	Shank diameter
FLGW	Flange width
GAN	Insert rake angle
GB	Face land angle
HTB	Body height
IC	Inscribed circle diameter
INSD	Insert diameter
INSL	Insert length
KRINS	Major cutting edge angle
L	Cutting edge length
LB	Body length
LCF	Chip flute length
LE	Cutting edge effective length
LF	Functional length
LFS	Secondary functional length
LH	Head length
LPR	Protruding length
LS	Shank length
LSC	Clamping length
LU	Usable length
LUX	Maximum usable length
M	M-dimension
OAL	Overall length
RE	Corner radius
S	Insert thickness
TDZ	Thread diameter size
WB	Body width
WF	Functional width

For high performance machining



High performance and Universal solutions What are you looking for in your solid drill application?

Seco Universal – Versatile general performance solid carbide drill

Seco Universal is a multi purpose general performance solid carbide drill, that can be used in a wide range of materials and applications in all industry segments. Thanks to the design with a strong self centering 140 degree drill point, polished chip flutes and the excellent quality of the drill - high capacity utilization, application security and versatility is provided at a very low cost.

With Seco Universal stock holding cost can be reduced and greater machining flexibility is offered, leading to reduced set-up time.

Seco Universal is an alternative to Seco Feedmax in operations when versatility, flexibility and reduced stock holding cost are the main targets.

Seco Feedmax™ – Productive high performance solid carbide drill

Seco Feedmax™ offers a unique combination of state-of-the-art carbide, coating- and geometry technology.

Seco Feedmax™ is designed for high productivity and low cost per hole with high feeds up to 0,70 mm/rev and high cutting speeds up to 220 m/min. With excellent centering capabilities - high hole quality is achieved with no need for centre drilling operations. Thanks to the modern coating with high hot hardness, the strong cutting edges with protective corner chamfers, high strength carbide rod, excellent chip evacuation capabilities and a superb cutting edge quality - a long and predictable tool life is achieved.

Seco Feedmax™ has a wide range of optimized geometries for different materials and applications, to obtain a good quality hole at the lowest cost.

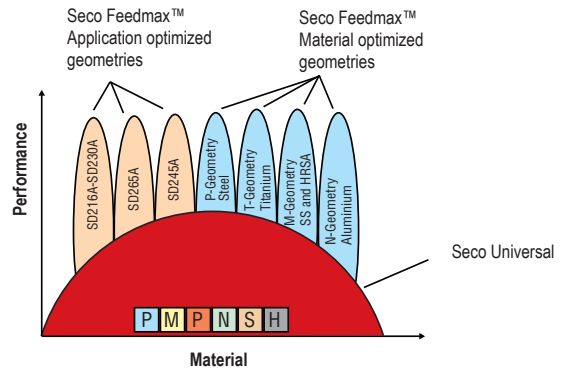
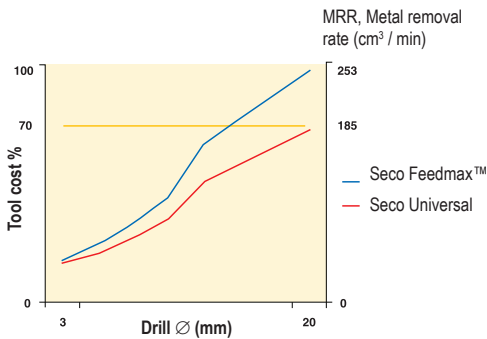

Tool life, lower cutting data

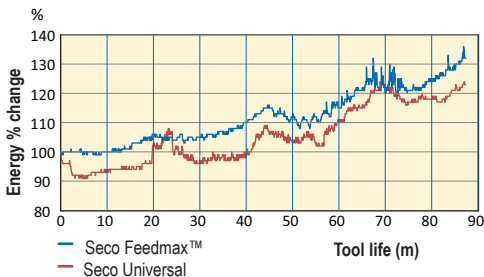

First hole is set as reference, 100% based on the spindle power Cutting data

$v_c = 90\text{m/min}$

$f = 0,15\text{ mm/rev}$

Material =SMG P5-P6, SS2244, DIN41CrMo4, AISI 4140

Tool life, high cutting data

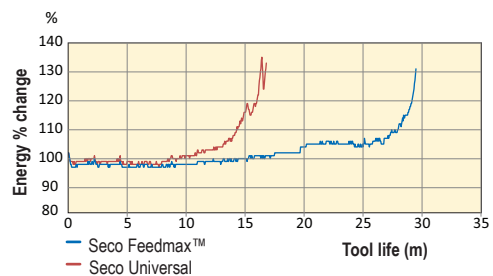

First hole is set as reference, 100% based on the spindle power Cutting data

$V_c = 160\text{ m/min}$

$f = 0,24\text{ mm/rev}$

Material =SMG P5-P6, SS2244, DIN41CrMo4, AISI 4140

Range overview

Seco Feedmax™	∅ Range	Drill depth	Drill ∅ tolerance	Hole tolerance (1)	Surface finish (2)
SD1103, SD1103A Universal  Page(s) 27-34	3-20 mm	~ 3 x D	m7	IT 8-9	R _a 1-2 μm
SD1105A Universal  Page(s) 35-39	3-20 mm	~ 5 x D	m7	IT 8-9	R _a 1-2 μm
SD203A-P  Page(s) 40-44	2-20 mm	~ 3 x D	m7	IT 8-9	R _a 1-2 μm
SD205A-P  Page(s) 45-50	2-20 mm	~ 5 x D	m7	IT 8-9	R _a 1-2 μm
SD206, SD206A  Page(s) 51-52	0,7-2,0 mm	~ 6 x D	h6	IT 9	R _a 1-2 μm

1) Variations can occur depending on the material and the cutting data used.

2) Drill depth, cutting data, coolant pressure and material can cause deterioration of the surface finish.

Range overview

Seco Feedmax™	∅ Range	Drill depth	Drill ∅ tolerance	Hole tolerance (1)	Surface finish (2)
SD207A  Page(s) 53-54	4,5-20 mm	~ 7 x D	m7	IT 9	R _a 1-3 μm
SD216A  Page(s) 55	3-12 mm	~ 16 x D	m7	IT 9	R _a 1-3 μm
SD230A  Page(s) 56	4-10 mm	~ 30 x D	m7	IT 9	R _a 1-3 μm
SD245A  Page(s) 57	5-14 mm	~ 5 x D	m7	IT 8	R _a 1-2 μm
SD265A  Page(s) 58	6-16 mm	~ 5 x D	js6	IT 7	R _a 1-2 μm

1) Variations can occur depending on the material and the cutting data used.

2) Drill depth, cutting data, coolant pressure and material can cause deterioration of the surface finish.



Range overview

Seco Feedmax™	∅ Range	Drill depth	Drill ∅ tolerance	Hole tolerance (1)	Surface finish (2)
SD203A-M, SD205A-M Superalloys  Page(s) 64-66	3-20 mm	~ 3 x D, ~ 5 x D	m7	IT 8-9	R _a 1-2 µm
SD203A-T, SD205A-T Titanium alloys  Page(s) 68-69	3-20 mm	~ 3 x D, ~ 5 x D	m7	IT 8-9	R _a 1-2 µm
SD203A-N Aluminium  Page(s) 70	2,5-14 mm	~ 3 x D	m7	IT 8-9	R _a 1-2 µm
SD205A-C1, -C2 Diamond coated drills for composites  Page(s) 73-74	3-12 mm	~ 5 x D	m7	-	-

1) Variations can occur depending on the material and the cutting data used.

2) Drill depth, cutting data, coolant pressure and material can cause deterioration of the surface finish.

Range overview

Seco Feedmax™	∅ Range	Drill depth	Drill ∅ tolerance	Hole tolerance (1)	Surface finish (2)
SD205-CX1, -CX2, -CX31 PCD drills for composites  Page(s) 75-77	4-8 mm	~ 5 x D	m7	-	-
SD22  Page(s) 79-83	0,1-2,0 mm	~ 2 x D	0,005/0	-	-
SD26  Page(s) 84-88	0,1-2,0 mm	~ 6 x D	0/-0,004	-	-

1) Variations can occur depending on the material and the cutting data used.

2) Drill depth, cutting data, coolant pressure and material can cause deterioration of the surface finish.

Code key Seco Universal

Type of drill
Solid carbide drill:
SD1103: ~3 x D
SD1105: ~5 x D

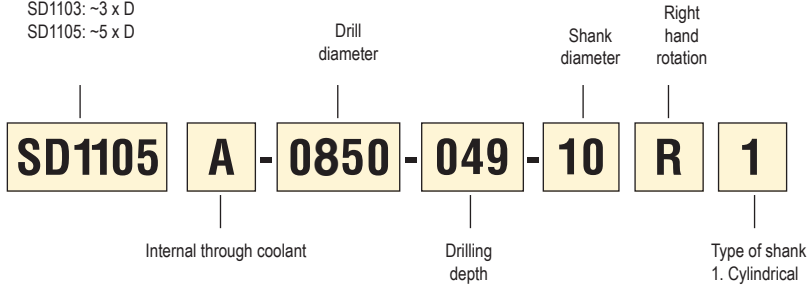

Code key Seco Feedmax™

Type of drill
Solid carbide drill:
SD203: ~3 x D
SD205: ~5 x D
SD206: ~6 x D
SD207: ~7 x D

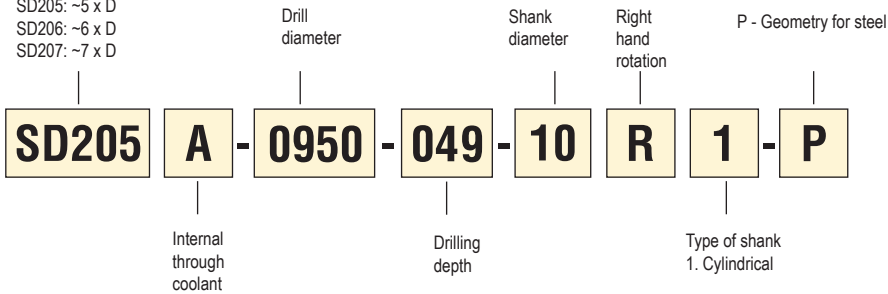

Type of drill
Solid carbide drill:
SD216: ~16 x D
SD230: ~30 x D
SD245: ~5 x D
SD265: ~5 x D
SD22: ~2 x D
SD26: ~6 x D

M - Geometry for superalloys
T - Geometry for titanium alloys
N - Geometry for aluminium
C1 - Geometry for CFRP and exiting in CFRP
C2 - Geometry for CFRP and exiting in i.e. Ti or Al
CX1/CX2/CX3 - PCD drills for CFRP and GFRP

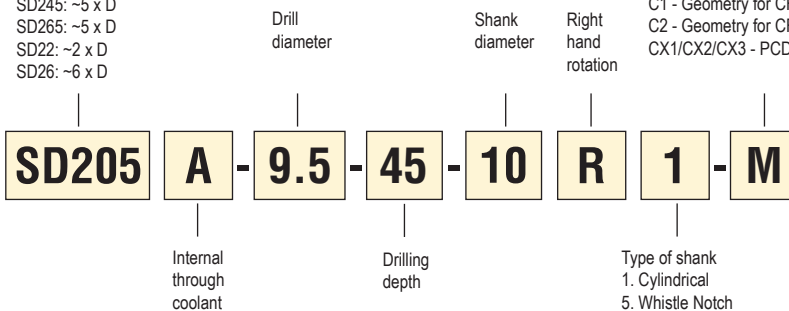

Set up

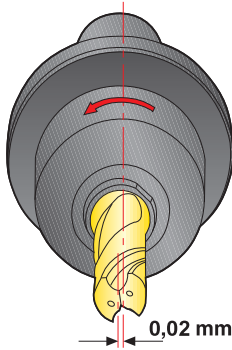

Holding/run-out

Drills with cylindrical shanks can be used with Shrinkfit holder, hydraulic chucks or collet chucks.

Keep the total indicated run-out of the drill within 0,04 mm measured in the spindle.

For best result keep run-out 0,02 mm.

Stability

The stability of the application is important to obtain the best tool life and hole accuracy. Check the condition of the machine spindle, fixture and fixturing of the component to secure maximum stability and rigidity. Unstable conditions can cause tool breakages.

Tool life

Drills should not be used with flank wear exceeding 0,1–0,3 mm measured at the largest point.

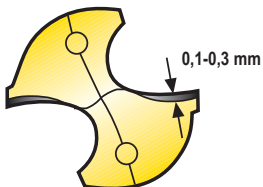

Recommended tool holders

For best result use holders:

Type 5603 - Shrinkfit holders, DIN type

Type 5834 - Hydraulic chucks

Type 5672 - High precision collet chucks

For more information see Tooling Systems catalogue

Shrinkfit holder

(For cylindrical, R1 shanks only)



Hydraulic chuck

(For cylindrical, -R1 shanks only)



High precision collet chucks

(For cylindrical, R1 shanks only)



Machining methods

Hole entrance on a machined surface

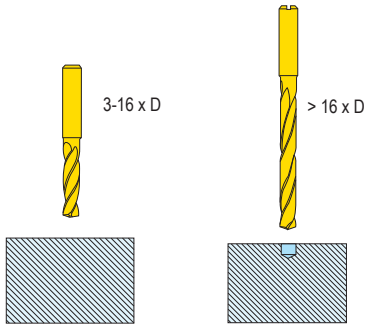

No pre-drilling or entrance feed needed.

When using a longer drill it's recommended to drill a pilot hole.

Angled hole exits

Before hole exit reduce the feed/rev by 50%.

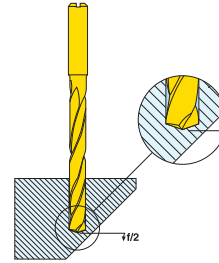

Or use SD245A drills.

Irregular/angled hole entrance

If irregular or angle entrance use pre operations accordingly

Pre drill with a short standard Feedmax

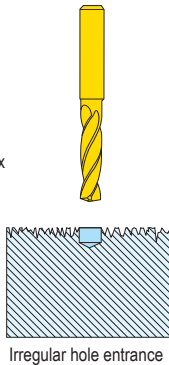

Irregular hole entrance

Pre-machining alternatives

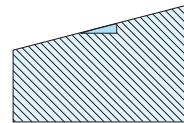

Angled hole entrance

Machine a flat using an end mill from the Seco range

Coolant recommendations

Coolant pressure*

Minimum recommended coolant pressure 10 bar with $\leq 5 \times D$

Minimum recommended coolant pressure 30 bar with $> 5 \times D$

Minimum recommended coolant pressure 40 bar with $> 16 \times D$

Coolant mix

Recommended emulsion mix 6-8%. When drilling in stainless steels, superalloys and high strength steels a mix of 10% is recommended.

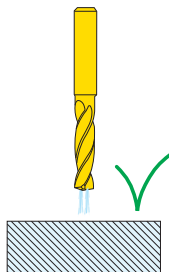

First choice

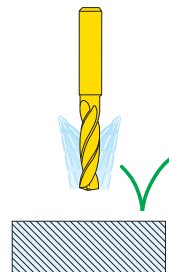

$\leq 5 \times D$

* If lower coolant pressure is used adjust by reducing cutting data accordingly.

Machining methods - SD216A (16 x D) up to SD230A (30 x D)

Step by step

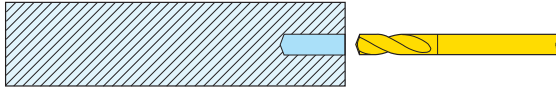

1. Drill a pilot hole 2-3 x D. Use a standard drill with the same diameter i.e. SD203A or SD1103 (with 140° point angle).

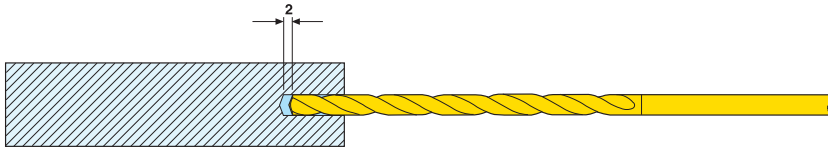

2. Enter the hole with the machine spindle stopped or use a low rpm (500). Stop 2 mm above the pilot hole depth.

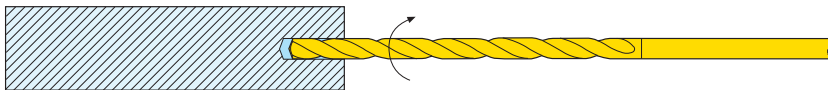

3. Start the machine spindle and the coolant, drill with the recommended cutting data. (No peck drilling).

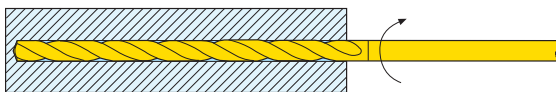

4. When reaching full depth, reduce the rpm to 500 and then retract the drill with 4 times the work feed to avoid retraction marks.

Machining methods – Micro drills

Pilot hole

SD22

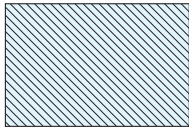

SD26

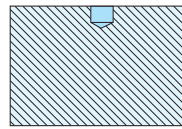

For optimal hole tolerance and positioning accuracy use an SD22 pilot drill of the same diameter.
Below 1 mm diameter drill we highly recommend to use a pilot drill.

Pecking

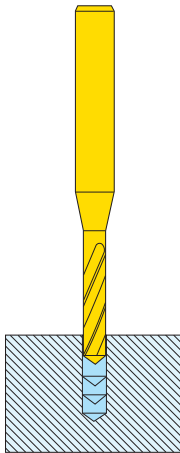

For long chipping materials a pecking cycle should be used.
Generally peck every 1 x D drilling depth.

Drilling depth ~ 3 x D

Cylindrical shank DIN 6537A



- External coolant
- Point angle: 140°
- Coating: AlCrN
- Hole tolerance: IT8-9
- For cutting data see page(s) 101

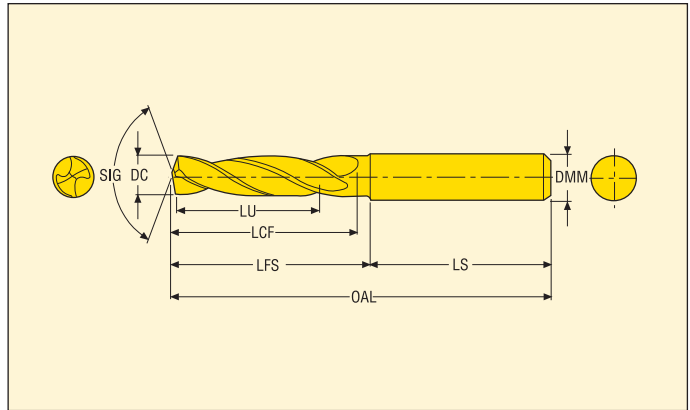

DC m7 (mm)	DC m7 (inch)	LU	Ordering and Product No.	Designation	Dimensions in mm				
					OAL	LFS	LS	LCF	DMM
3.0	–	14	02898974	SD1103-0300-014-06R1	62	26	36	20	6
3.1	–	14	02898975	SD1103-0310-014-06R1	62	26	36	20	6
3.2	–	14	02898977	SD1103-0320-014-06R1	62	26	36	20	6
3.25	–	14	02898978	SD1103-0325-014-06R1	62	26	36	20	6
3.3	–	14	02898979	SD1103-0330-014-06R1	62	26	36	20	6
3.4	–	14	02898980	SD1103-0340-014-06R1	62	26	36	20	6
3.5	–	14	02898981	SD1103-0350-014-06R1	62	26	36	20	6
3.6	–	14	02898983	SD1103-0360-014-06R1	62	26	36	20	6
3.65	–	14	02898984	SD1103-0365-014-06R1	62	26	36	20	6
3.7	–	14	02898985	SD1103-0370-014-06R1	62	26	36	20	6
3.8	–	17	02898986	SD1103-0380-017-06R1	66	30	36	24	6
3.9	–	17	02898987	SD1103-0390-017-06R1	66	30	36	24	6
4.0	–	17	02898989	SD1103-0400-017-06R1	66	30	36	24	6
4.1	–	17	02898990	SD1103-0410-017-06R1	66	30	36	24	6
4.2	–	17	02898991	SD1103-0420-017-06R1	66	30	36	24	6
4.3	–	17	02898992	SD1103-0430-017-06R1	66	30	36	24	6
4.4	–	17	02898994	SD1103-0440-017-06R1	66	30	36	24	6
4.5	–	17	02898995	SD1103-0450-017-06R1	66	30	36	24	6
4.6	–	17	02898996	SD1103-0460-017-06R1	66	30	36	24	6
4.65	–	17	02898997	SD1103-0465-017-06R1	66	30	36	24	6
4.7	–	17	02898998	SD1103-0470-017-06R1	66	30	36	24	6
4.8	–	20	02899000	SD1103-0480-020-06R1	66	30	36	28	6
4.9	–	20	02899001	SD1103-0490-020-06R1	66	30	36	28	6
5.0	–	20	02899002	SD1103-0500-020-06R1	66	30	36	28	6
5.1	–	20	02899003	SD1103-0510-020-06R1	66	30	36	28	6
5.159	13/64	20	02899004	SD1103-0516-020-06R1	66	30	36	28	6
5.2	–	20	02899005	SD1103-0520-020-06R1	66	30	36	28	6
5.3	–	20	02899006	SD1103-0530-020-06R1	66	30	36	28	6
5.4	–	20	02899007	SD1103-0540-020-06R1	66	30	36	28	6
5.5	–	20	02899008	SD1103-0550-020-06R1	66	30	36	28	6
5.55	–	20	02899009	SD1103-0555-020-06R1	66	30	36	28	6
5.6	–	20	02899011	SD1103-0560-020-06R1	66	30	36	28	6
5.7	–	20	02899012	SD1103-0570-020-06R1	66	30	36	28	6
5.8	–	20	02899013	SD1103-0580-020-06R1	66	30	36	28	6
5.9	–	20	02899014	SD1103-0590-020-06R1	66	30	36	28	6
5.953	15/64	20	02899015	SD1103-0595-020-06R1	66	30	36	28	6

Drilling depth ~ 3 x D

Cylindrical shank DIN 6537A

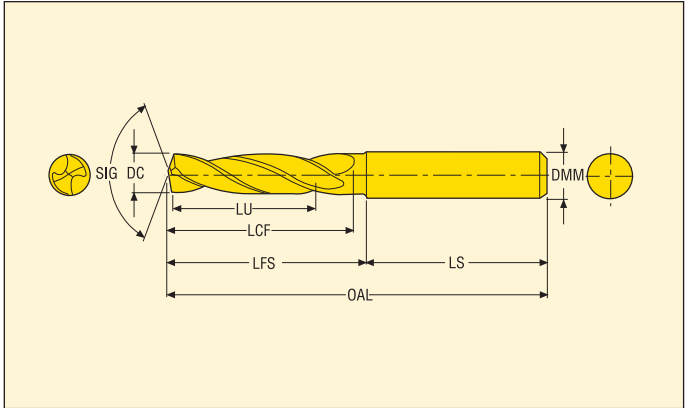

- External coolant
- Point angle: 140°
- Coating: AlCrN
- Hole tolerance: IT8-9
- For cutting data see page(s) 101

DC m7 (mm)	DC m7 (inch)	LU	Ordering and Product No.	Designation	Dimensions in mm				
					OAL	LFS	LS	LCF	DMM
6.0	–	20	02899016	SD1103-0600-020-06R1	66	30	36	28	6
6.1	–	24	02899017	SD1103-0610-024-08R1	79	43	36	34	8
6.2	–	24	02899018	SD1103-0620-024-08R1	79	43	36	34	8
6.3	–	24	02899019	SD1103-0630-024-08R1	79	43	36	34	8
6,35	1/4	24	02899020	SD1103-0635-024-08R1	79	43	36	34	8
6.4	–	24	02899021	SD1103-0640-024-08R1	79	43	36	34	8
6.5	–	24	02899022	SD1103-0650-024-08R1	79	43	36	34	8
6.6	–	24	02899024	SD1103-0660-024-08R1	79	43	36	34	8
6,747	17/64	24	02899025	SD1103-0675-024-08R1	79	43	36	34	8
6.8	–	24	02899026	SD1103-0680-024-08R1	79	43	36	34	8
6.9	–	24	02899027	SD1103-0690-024-08R1	79	43	36	34	8
7.0	–	24	02899028	SD1103-0700-024-08R1	79	43	36	34	8
7.1	–	29	02899029	SD1103-0710-029-08R1	79	43	36	41	8
7,144	9/32	29	02899030	SD1103-0714-029-08R1	79	43	36	41	8
7.2	–	29	02899031	SD1103-0720-029-08R1	79	43	36	41	8
7.3	–	29	02899032	SD1103-0730-029-08R1	79	43	36	41	8
7.4	–	29	02899033	SD1103-0740-029-08R1	79	43	36	41	8
7.5	–	29	02899034	SD1103-0750-029-08R1	79	43	36	41	8
7,55	–	29	02899036	SD1103-0755-029-08R1	79	43	36	41	8
7.6	–	29	02899037	SD1103-0760-029-08R1	79	43	36	41	8
7.7	–	29	02899038	SD1103-0770-029-08R1	79	43	36	41	8
7.8	–	29	02899040	SD1103-0780-029-08R1	79	43	36	41	8
7.9	–	29	02899041	SD1103-0790-029-08R1	79	43	36	41	8
7,938	5/16	29	02899042	SD1103-0794-029-08R1	79	43	36	41	8
8.0	–	29	02899043	SD1103-0800-029-08R1	79	43	36	41	8
8.1	–	35	02899044	SD1103-0810-035-10R1	89	49	40	47	10
8.2	–	35	02899045	SD1103-0820-035-10R1	89	49	40	47	10
8.3	–	35	02899046	SD1103-0830-035-10R1	89	49	40	47	10
8.4	–	35	02899048	SD1103-0840-035-10R1	89	49	40	47	10
8.5	–	35	02899049	SD1103-0850-035-10R1	89	49	40	47	10
8.6	–	35	02899050	SD1103-0860-035-10R1	89	49	40	47	10
8.7	–	35	02899051	SD1103-0870-035-10R1	89	49	40	47	10
8.8	–	35	02899053	SD1103-0880-035-10R1	89	49	40	47	10
8.9	–	35	02899054	SD1103-0890-035-10R1	89	49	40	47	10
9.0	–	35	02899055	SD1103-0900-035-10R1	89	49	40	47	10
9.1	–	35	02899056	SD1103-0910-035-10R1	89	49	40	47	10
9,128	23/64	35	02899058	SD1103-0913-035-10R1	89	49	40	47	10
9.2	–	35	02899059	SD1103-0920-035-10R1	89	49	40	47	10
9.3	–	35	02899060	SD1103-0930-035-10R1	89	49	40	47	10

Drilling depth ~ 3 x D

Cylindrical shank DIN 6537A



- External coolant
- Point angle: 140°
- Coating: AlCrN
- Hole tolerance: IT8-9
- For cutting data see page(s) 101

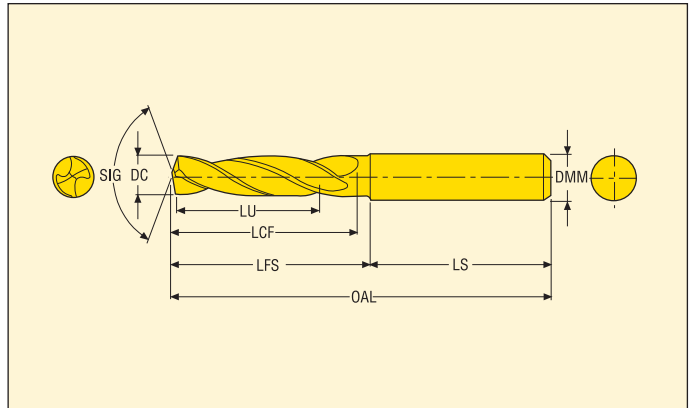

DC m7 (mm)	DC m7 (inch)	LU	Ordering and Product No.	Designation	Dimensions in mm				
					OAL	LFS	LS	LCF	DMM
9,4	-	35	02899061	SD1103-0940-035-10R1	89	49	40	47	10
9,5	-	35	02899062	SD1103-0950-035-10R1	89	49	40	47	10
9,55	-	35	02899064	SD1103-0955-035-10R1	89	49	40	47	10
9,6	-	35	02899065	SD1103-0960-035-10R1	89	49	40	47	10
9,7	-	35	02899066	SD1103-0970-035-10R1	89	49	40	47	10
9,8	-	35	02899067	SD1103-0980-035-10R1	89	49	40	47	10
9,9	-	35	02899068	SD1103-0990-035-10R1	89	49	40	47	10
9,922	25/64	35	02899069	SD1103-0992-035-10R1	89	49	40	47	10
10,0	-	35	02899070	SD1103-1000-035-10R1	89	49	40	47	10
10,2	-	40	02899071	SD1103-1020-040-12R1	102	57	45	55	12
10,319	12/32	40	02899072	SD1103-1032-040-12R1	102	57	45	55	12
10,4	-	40	02899073	SD1103-1040-040-12R1	102	57	45	55	12
10,5	-	40	02899074	SD1103-1050-040-12R1	102	57	45	55	12
10,6	-	40	02899075	SD1103-1060-040-12R1	102	57	45	55	12
10,8	-	40	02899077	SD1103-1080-040-12R1	102	57	45	55	12
10,9	-	40	02899078	SD1103-1090-040-12R1	102	57	45	55	12
11,0	-	40	02899079	SD1103-1100-040-12R1	102	57	45	55	12
11,1	-	40	02899080	SD1103-1110-040-12R1	102	57	45	55	12
11,113	7/16	40	02899081	SD1103-1111-040-12R1	102	57	45	55	12
11,2	-	40	02899082	SD1103-1120-040-12R1	102	57	45	55	12
11,3	-	40	02899083	SD1103-1130-040-12R1	102	57	45	55	12
11,4	-	40	02899084	SD1103-1140-040-12R1	102	57	45	55	12
11,5	-	40	02899085	SD1103-1150-040-12R1	102	57	45	55	12
11,509	29/64	40	02899086	SD1103-1151-040-12R1	102	57	45	55	12
11,55	-	40	02899087	SD1103-1155-040-12R1	102	57	45	55	12
11,6	-	40	02899088	SD1103-1160-040-12R1	102	57	45	55	12
11,7	-	40	02899089	SD1103-1170-040-12R1	102	57	45	55	12
11,8	-	40	02899090	SD1103-1180-040-12R1	102	57	45	55	12
11,9	-	40	02899091	SD1103-1190-040-12R1	102	57	45	55	12
12,0	-	40	02899093	SD1103-1200-040-12R1	102	57	45	55	12
12,1	-	43	02899094	SD1103-1210-043-14R1	107	62	45	60	14
12,2	-	43	02899095	SD1103-1220-043-14R1	107	62	45	60	14
12,303	31/64	43	02899096	SD1103-1230-043-14R1	107	62	45	60	14
12,4	-	43	02899097	SD1103-1240-043-14R1	107	62	45	60	14
12,5	-	43	02899098	SD1103-1250-043-14R1	107	62	45	60	14
12,6	-	43	02899099	SD1103-1260-043-14R1	107	62	45	60	14
12,7	1/2	43	02899100	SD1103-1270-043-14R1	107	62	45	60	14
12,75	-	43	02899101	SD1103-1275-043-14R1	107	62	45	60	14
12,8	-	43	02899102	SD1103-1280-043-14R1	107	62	45	60	14

Drilling depth ~ 3 x D

Cylindrical shank DIN 6537A

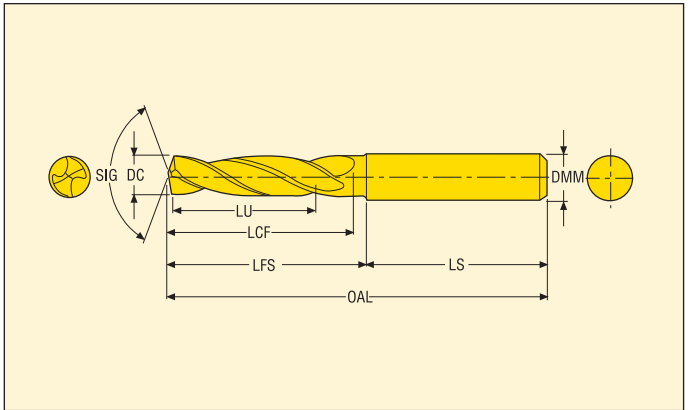

- External coolant
- Point angle: 140°
- Coating: AlCrN
- Hole tolerance: IT8-9
- For cutting data see page(s) 101

DC m7 (mm)	DC m7 (inch)	LU	Ordering and Product No.	Designation	Dimensions in mm				
					OAL	LFS	LS	LCF	DMM
12.9	-	43	02899103	SD1103-1290-043-14R1	107	62	45	60	14
13.0	-	43	02899104	SD1103-1300-043-14R1	107	62	45	60	14
13.1	-	43	02899105	SD1103-1310-043-14R1	107	62	45	60	14
13.2	-	43	02899106	SD1103-1320-043-14R1	107	62	45	60	14
13.3	-	43	02899107	SD1103-1330-043-14R1	107	62	45	60	14
13.4	-	43	02899108	SD1103-1340-043-14R1	107	62	45	60	14
13.494	17/32	43	02899109	SD1103-1349-043-14R1	107	62	45	60	14
13.5	-	43	02899110	SD1103-1350-043-14R1	107	62	45	60	14
13.6	-	43	02899111	SD1103-1360-043-14R1	107	62	45	60	14
13.7	-	43	02899112	SD1103-1370-043-14R1	107	62	45	60	14
13.8	-	43	02899113	SD1103-1380-043-14R1	107	62	45	60	14
13.9	-	43	02899114	SD1103-1390-043-14R1	107	62	45	60	14
14.0	-	43	02899115	SD1103-1400-043-14R1	107	62	45	60	14
14.2	-	45	02899116	SD1103-1420-045-16R1	115	67	48	65	16
14.5	-	45	02899119	SD1103-1450-045-16R1	115	67	48	65	16
14.7	-	45	02899120	SD1103-1470-045-16R1	115	67	48	65	16
14.75	-	45	02899121	SD1103-1475-045-16R1	115	67	48	65	16
14.8	-	45	02899122	SD1103-1480-045-16R1	115	67	48	65	16
15.0	-	45	02899123	SD1103-1500-045-16R1	115	67	48	65	16
15.1	-	45	02899124	SD1103-1510-045-16R1	115	67	48	65	16
15.3	-	45	02899125	SD1103-1530-045-16R1	115	67	48	65	16
15.5	-	45	02899126	SD1103-1550-045-16R1	115	67	48	65	16
15.7	-	45	02899127	SD1103-1570-045-16R1	115	67	48	65	16
15.8	-	45	02899128	SD1103-1580-045-16R1	115	67	48	65	16
16.0	-	45	02899130	SD1103-1600-045-16R1	115	67	48	65	16
16.5	-	51	02899131	SD1103-1650-051-18R1	123	75	48	73	18
17.0	-	51	02899132	SD1103-1700-051-18R1	123	75	48	73	18
17.5	-	51	02899133	SD1103-1750-051-18R1	123	75	48	73	18
18.0	-	51	02899134	SD1103-1800-051-18R1	123	75	48	73	18
18.5	-	55	02899135	SD1103-1850-055-20R1	131	81	50	79	20
19.0	-	55	02899136	SD1103-1900-055-20R1	131	81	50	79	20
19.05	3/4	55	02899137	SD1103-1905-055-20R1	131	81	50	79	20
19.5	-	55	02899138	SD1103-1950-055-20R1	131	81	50	79	20
20.0	-	55	02899139	SD1103-2000-055-20R1	131	81	50	79	20

Drilling depth ~ 3 x D

Cylindrical shank DIN 6537A



- Internal coolant
- Point angle: 140°
- Coating: AlCrN
- Hole tolerance: IT8-9
- For cutting data see page(s) 101

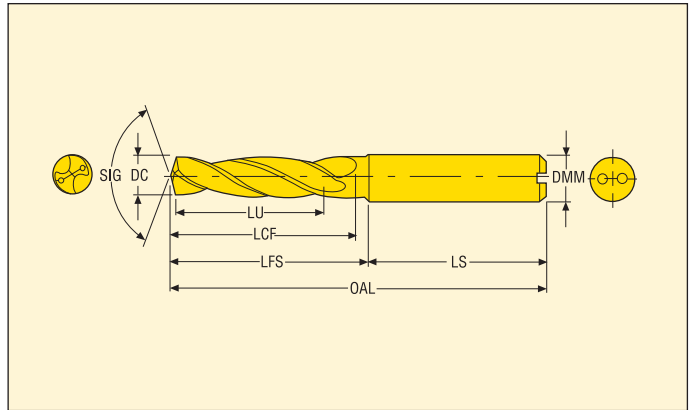

DC m7 (mm)	DC m7 (inch)	LU	Ordering and Product No.	Designation	Dimensions in mm				
					OAL	LFS	LS	LCF	DMM
3,0	–	14	02898244	SD1103A-0300-014-06R1	62	26	36	20	6
3,1	–	14	02898245	SD1103A-0310-014-06R1	62	26	36	20	6
3,175	1/8	14	02898246	SD1103A-0318-014-06R1	62	26	36	20	6
3,2	–	14	02898247	SD1103A-0320-014-06R1	62	26	36	20	6
3,25	–	14	02898248	SD1103A-0325-014-06R1	62	26	36	20	6
3,3	–	14	02898249	SD1103A-0330-014-06R1	62	26	36	20	6
3,4	–	14	02898250	SD1103A-0340-014-06R1	62	26	36	20	6
3,5	–	14	02898251	SD1103A-0350-014-06R1	62	26	36	20	6
3,572	9/64	14	02898252	SD1103A-0357-014-06R1	62	26	36	20	6
3,6	–	14	02898253	SD1103A-0360-014-06R1	62	26	36	20	6
3,65	–	14	02898254	SD1103A-0365-014-06R1	62	26	36	20	6
3,7	–	14	02898255	SD1103A-0370-014-06R1	62	26	36	20	6
3,8	–	17	02898256	SD1103A-0380-017-06R1	66	30	36	24	6
3,9	–	17	02898257	SD1103A-0390-017-06R1	66	30	36	24	6
3,969	5/32	17	02898258	SD1103A-0397-017-06R1	66	30	36	24	6
4,0	–	17	02898259	SD1103A-0400-017-06R1	66	30	36	24	6
4,1	–	17	02898260	SD1103A-0410-017-06R1	66	30	36	24	6
4,2	–	17	02898261	SD1103A-0420-017-06R1	66	30	36	24	6
4,3	–	17	02898262	SD1103A-0430-017-06R1	66	30	36	24	6
4,366	11/64	17	02898263	SD1103A-0437-017-06R1	66	30	36	24	6
4,5	–	17	02898264	SD1103A-0450-017-06R1	66	30	36	24	6
4,6	–	17	02898265	SD1103A-0460-017-06R1	66	30	36	24	6
4,65	–	17	02898266	SD1103A-0465-017-06R1	66	30	36	24	6
4,7	–	17	02898267	SD1103A-0470-017-06R1	66	30	36	24	6
4,8	–	20	02898269	SD1103A-0480-020-06R1	66	30	36	28	6
4,9	–	20	02898270	SD1103A-0490-020-06R1	66	30	36	28	6
5,0	–	20	02898271	SD1103A-0500-020-06R1	66	30	36	28	6
5,1	–	20	02898272	SD1103A-0510-020-06R1	66	30	36	28	6
5,2	–	20	02898275	SD1103A-0520-020-06R1	66	30	36	28	6
5,3	–	20	02898276	SD1103A-0530-020-06R1	66	30	36	28	6
5,4	–	20	02898277	SD1103A-0540-020-06R1	66	30	36	28	6
5,5	–	20	02898278	SD1103A-0550-020-06R1	66	30	36	28	6
5,55	7/32	20	02898280	SD1103A-0556-020-06R1	66	30	36	28	6
5,6	–	20	02898281	SD1103A-0560-020-06R1	66	30	36	28	6
5,7	–	20	02898282	SD1103A-0570-020-06R1	66	30	36	28	6
5,8	–	20	02898283	SD1103A-0580-020-06R1	66	30	36	28	6
5,9	–	20	02898284	SD1103A-0590-020-06R1	66	30	36	28	6
5,953	–	20	02898285	SD1103A-0595-020-06R1	66	30	36	28	6
6,0	–	20	02898286	SD1103A-0600-020-06R1	66	30	36	28	6

Drilling depth ~ 3 x D

Cylindrical shank DIN 6537A

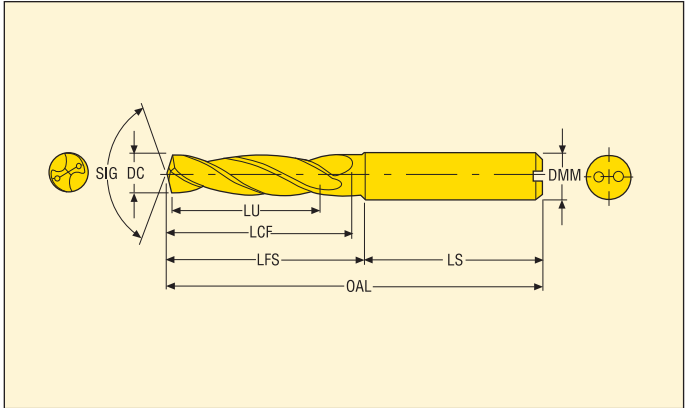

- Internal coolant
- Point angle: 140°
- Coating: AlCrN
- Hole tolerance: IT8-9
- For cutting data see page(s) 101

DC m7 (mm)	DC m7 (inch)	LU	Ordering and Product No.	Designation	Dimensions in mm				
					OAL	LFS	LS	LCF	DMM
6.1	–	24	02898287	SD1103A-0610-024-08R1	79	43	36	34	8
6.2	–	24	02898288	SD1103A-0620-024-08R1	79	43	36	34	8
6.3	–	24	02898289	SD1103A-0630-024-08R1	79	43	36	34	8
6.35	1/4	24	02898290	SD1103A-0635-024-08R1	79	43	36	34	8
6.4	–	24	02898291	SD1103A-0640-024-08R1	79	43	36	34	8
6.5	–	24	02898292	SD1103A-0650-024-08R1	79	43	36	34	8
6.6	–	24	02898293	SD1103A-0660-024-08R1	79	43	36	34	8
6.7	–	24	02898294	SD1103A-0670-024-08R1	79	43	36	34	8
6.747	17/64	24	02898295	SD1103A-0675-024-08R1	79	43	36	34	8
6.8	–	24	02898296	SD1103A-0680-024-08R1	79	43	36	34	8
6.9	–	24	02898297	SD1103A-0690-024-08R1	79	43	36	34	8
7.0	–	24	02898298	SD1103A-0700-024-08R1	79	43	36	34	8
7.1	–	29	02898299	SD1103A-0710-029-08R1	79	43	36	41	8
7.144	9/32	29	02898300	SD1103A-0714-029-08R1	79	43	36	41	8
7.2	–	29	02898301	SD1103A-0720-029-08R1	79	43	36	41	8
7.3	–	29	02898302	SD1103A-0730-029-08R1	79	43	36	41	8
7.4	–	29	02898303	SD1103A-0740-029-08R1	79	43	36	41	8
7.5	–	29	02898304	SD1103A-0750-029-08R1	79	43	36	41	8
7.55	–	29	02898306	SD1103A-0755-029-08R1	79	43	36	41	8
7.6	–	29	02898307	SD1103A-0760-029-08R1	79	43	36	41	8
7.7	–	29	02898308	SD1103A-0770-029-08R1	79	43	36	41	8
7.8	–	29	02898309	SD1103A-0780-029-08R1	79	43	36	41	8
7.9	–	29	02898310	SD1103A-0790-029-08R1	79	43	36	41	8
7.938	5/16	29	02898311	SD1103A-0794-029-08R1	79	43	36	41	8
8.0	–	29	02898312	SD1103A-0800-029-08R1	79	43	36	41	8
8.1	–	35	02898313	SD1103A-0810-035-10R1	89	49	40	47	10
8.2	–	35	02898314	SD1103A-0820-035-10R1	89	49	40	47	10
8.3	–	35	02898315	SD1103A-0830-035-10R1	89	49	40	47	10
8.334	21/64	35	02898316	SD1103A-0833-035-10R1	89	49	40	47	10
8.4	–	35	02898317	SD1103A-0840-035-10R1	89	49	40	47	10
8.5	–	35	02898318	SD1103A-0850-035-10R1	89	49	40	47	10
8.6	–	35	02898319	SD1103A-0860-035-10R1	89	49	40	47	10
8.7	–	35	02898320	SD1103A-0870-035-10R1	89	49	40	47	10
8.8	–	35	02898322	SD1103A-0880-035-10R1	89	49	40	47	10
8.9	–	35	02898323	SD1103A-0890-035-10R1	89	49	40	47	10
9.0	–	35	02898324	SD1103A-0900-035-10R1	89	49	40	47	10
9.1	–	35	02898325	SD1103A-0910-035-10R1	89	49	40	47	10
9.128	23/64	35	02898326	SD1103A-0913-035-10R1	89	49	40	47	10
9.2	–	35	02898327	SD1103A-0920-035-10R1	89	49	40	47	10
9.3	–	35	02898328	SD1103A-0930-035-10R1	89	49	40	47	10

Drilling depth ~ 3 x D

Cylindrical shank DIN 6537A

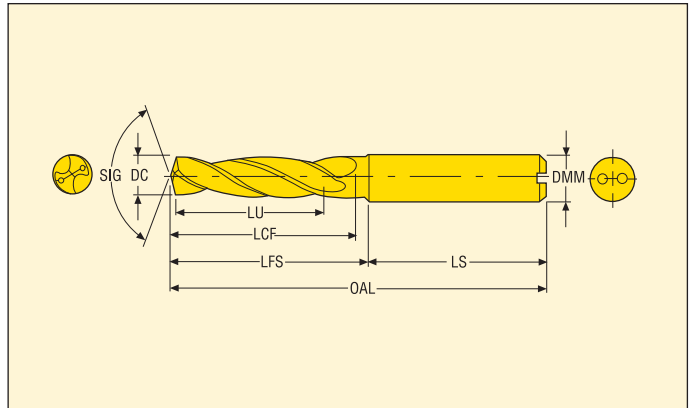

- Internal coolant
- Point angle: 140°
- Coating: AlCrN
- Hole tolerance: IT8-9
- For cutting data see page(s) 101

DC m7 (mm)	DC m7 (inch)	LU	Ordering and Product No.	Designation	Dimensions in mm				
					OAL	LFS	LS	LCF	DMM
9,4	-	35	02898329	SD1103A-0940-035-10R1	89	49	40	47	10
9,5	-	35	02898330	SD1103A-0950-035-10R1	89	49	40	47	10
9,55	-	35	02898332	SD1103A-0955-035-10R1	89	49	40	47	10
9,6	-	35	02898333	SD1103A-0960-035-10R1	89	49	40	47	10
9,7	-	35	02898334	SD1103A-0970-035-10R1	89	49	40	47	10
9,8	-	35	02898335	SD1103A-0980-035-10R1	89	49	40	47	10
9,9	-	35	02898336	SD1103A-0990-035-10R1	89	49	40	47	10
10,0	-	35	02898338	SD1103A-1000-035-10R1	89	49	40	47	10
10,2	-	40	02898339	SD1103A-1020-040-12R1	102	57	45	55	12
10,319	13/32	40	02898340	SD1103A-1032-040-12R1	102	57	45	55	12
10,4	-	40	02898341	SD1103A-1040-040-12R1	102	57	45	55	12
10,5	-	40	02898342	SD1103A-1050-040-12R1	102	57	45	55	12
10,6	-	40	02898343	SD1103A-1060-040-12R1	102	57	45	55	12
10,8	-	40	02898345	SD1103A-1080-040-12R1	102	57	45	55	12
10,9	-	40	02898346	SD1103A-1090-040-12R1	102	57	45	55	12
11,0	-	40	02898347	SD1103A-1100-040-12R1	102	57	45	55	12
11,1	-	40	02898348	SD1103A-1110-040-12R1	102	57	45	55	12
11,2	-	40	02898350	SD1103A-1120-040-12R1	102	57	45	55	12
11,3	-	40	02898351	SD1103A-1130-040-12R1	102	57	45	55	12
11,4	-	40	02898352	SD1103A-1140-040-12R1	102	57	45	55	12
11,5	-	40	02898353	SD1103A-1150-040-12R1	102	57	45	55	12
11,509	29/64	40	02898354	SD1103A-1151-040-12R1	102	57	45	55	12
11,55	-	40	02898355	SD1103A-1155-040-12R1	102	57	45	55	12
11,6	-	40	02898356	SD1103A-1160-040-12R1	102	57	45	55	12
11,7	-	40	02898357	SD1103A-1170-040-12R1	102	57	45	55	12
11,8	-	40	02898358	SD1103A-1180-040-12R1	102	57	45	55	12
11,9	-	40	02898359	SD1103A-1190-040-12R1	102	57	45	55	12
11,906	15/32	40	02898360	SD1103A-1191-040-12R1	102	57	45	55	12
12,0	-	40	02898361	SD1103A-1200-040-12R1	102	57	45	55	12
12,1	-	43	02898362	SD1103A-1210-043-14R1	107	62	45	60	14
12,2	-	43	02898363	SD1103A-1220-043-14R1	107	62	45	60	14
12,303	31/64	43	02898364	SD1103A-1230-043-14R1	107	62	45	60	14
12,4	-	43	02898365	SD1103A-1240-043-14R1	107	62	45	60	14
12,5	-	43	02898366	SD1103A-1250-043-14R1	107	62	45	60	14
12,6	-	43	02898367	SD1103A-1260-043-14R1	107	62	45	60	14
12,7	1/2	43	02898368	SD1103A-1270-043-14R1	107	62	45	60	14
12,75	-	43	02898369	SD1103A-1275-043-14R1	107	62	45	60	14
12,8	-	43	02898370	SD1103A-1280-043-14R1	107	62	45	60	14

Drilling depth ~ 3 x D

Cylindrical shank DIN 6537A

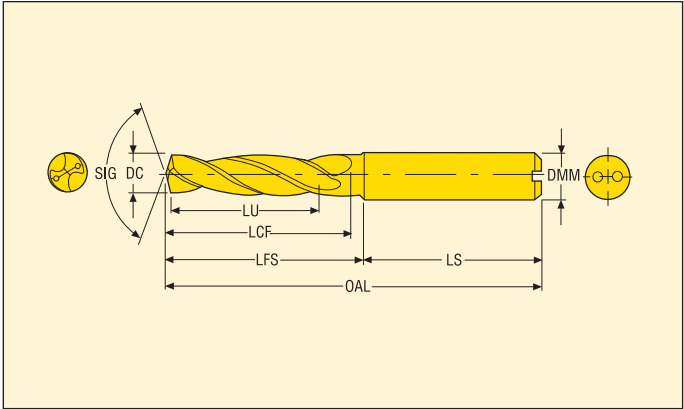

- Internal coolant
- Point angle: 140°
- Coating: AlCrN
- Hole tolerance: IT8-9
- For cutting data see page(s) 101

DC m7 (mm)	DC m7 (inch)	LU	Ordering and Product No.	Designation	Dimensions in mm				
					OAL	LFS	LS	LCF	DMM
12,9	-	43	02898371	SD1103A-1290-043-14R1	107	62	45	60	14
13,0	-	43	02898372	SD1103A-1300-043-14R1	107	62	45	60	14
13,1	-	43	02898373	SD1103A-1310-043-14R1	107	62	45	60	14
13,2	-	43	02898374	SD1103A-1320-043-14R1	107	62	45	60	14
13,3	-	43	02898375	SD1103A-1330-043-14R1	107	62	45	60	14
13,4	-	43	02898376	SD1103A-1340-043-14R1	107	62	45	60	14
13,494	17/32	43	02898377	SD1103A-1349-043-14R1	107	62	45	60	14
13,5	-	43	02898378	SD1103A-1350-043-14R1	107	62	45	60	14
13,6	-	43	02898379	SD1103A-1360-043-14R1	107	62	45	60	14
13,7	-	43	02898380	SD1103A-1370-043-14R1	107	62	45	60	14
13,8	-	43	02898381	SD1103A-1380-043-14R1	107	62	45	60	14
13,9	-	43	02898382	SD1103A-1390-043-14R1	107	62	45	60	14
14,0	-	43	02898383	SD1103A-1400-043-14R1	107	62	45	60	14
14,2	-	45	02898384	SD1103A-1420-045-16R1	115	67	48	65	16
14,5	-	45	02898386	SD1103A-1450-045-16R1	115	67	48	65	16
14,7	-	45	02898387	SD1103A-1470-045-16R1	115	67	48	65	16
14,75	-	45	02898388	SD1103A-1475-045-16R1	115	67	48	65	16
14,8	-	45	02898389	SD1103A-1480-045-16R1	115	67	48	65	16
15,0	-	45	02898390	SD1103A-1500-045-16R1	115	67	48	65	16
15,1	-	45	02898391	SD1103A-1510-045-16R1	115	67	48	65	16
15,3	-	45	02898392	SD1103A-1530-045-16R1	115	67	48	65	16
15,5	-	45	02898393	SD1103A-1550-045-16R1	115	67	48	65	16
15,7	-	45	02898394	SD1103A-1570-045-16R1	115	67	48	65	16
15,8	-	45	02898395	SD1103A-1580-045-16R1	115	67	48	65	16
16,0	-	45	02898397	SD1103A-1600-045-16R1	115	67	48	65	16
16,5	-	51	02898398	SD1103A-1650-051-18R1	123	75	48	73	18
17,0	-	51	02898399	SD1103A-1700-051-18R1	123	75	48	73	18
17,5	-	51	02898400	SD1103A-1750-051-18R1	123	75	48	73	18
18,0	-	51	02898401	SD1103A-1800-051-18R1	123	75	48	73	18
18,5	-	55	02898402	SD1103A-1850-055-20R1	131	81	50	79	20
19,0	-	55	02898403	SD1103A-1900-055-20R1	131	81	50	79	20
19,5	-	55	02898405	SD1103A-1950-055-20R1	131	81	50	79	20
20,0	-	55	02898406	SD1103A-2000-055-20R1	131	81	50	79	20

Drilling depth ~ 5 x D

Cylindrical shank DIN 6537A



- Internal coolant
- Point angle: 140°
- Coating: AlCrN
- Hole tolerance: IT8-9
- For cutting data see page(s) 101

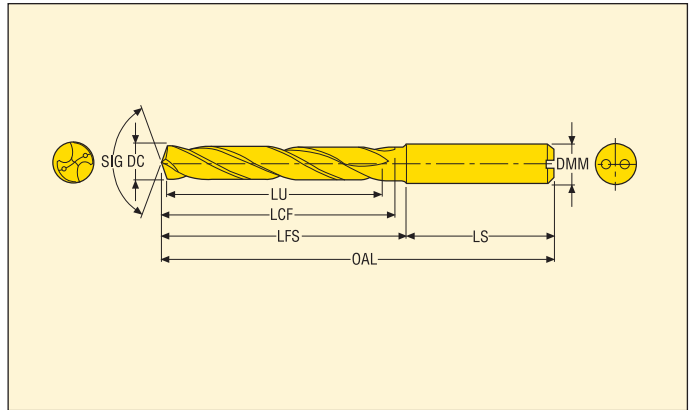

DC m7 (mm)	DC m7 (inch)	LU	Ordering and Product No.	Designation	Dimensions in mm				
					OAL	LFS	LS	LCF	DMM
3.0	-	23.0	02897845	SD1105A-0300-023-06R1	66.0	30.0	36.0	28.0	6.0
3.1	-	23.0	02897846	SD1105A-0310-023-06R1	66.0	30.0	36.0	28.0	6.0
3.2	-	23.0	02897848	SD1105A-0320-023-06R1	66.0	30.0	36.0	28.0	6.0
3.25	-	23.0	02897849	SD1105A-0325-023-06R1	66.0	30.0	36.0	28.0	6.0
3.3	-	23.0	02897850	SD1105A-0330-023-06R1	66.0	30.0	36.0	28.0	6.0
3.4	-	23.0	02897851	SD1105A-0340-023-06R1	66.0	30.0	36.0	28.0	6.0
3.5	-	23.0	02897852	SD1105A-0350-023-06R1	66.0	30.0	36.0	28.0	6.0
3.572	9/64	23.0	02897853	SD1105A-0357-023-06R1	66.0	30.0	36.0	28.0	6.0
3.6	-	23.0	02897854	SD1105A-0360-023-06R1	66.0	30.0	36.0	28.0	6.0
3.65	-	23.0	02897855	SD1105A-0365-023-06R1	66.0	30.0	36.0	28.0	6.0
3.7	-	23.0	02897856	SD1105A-0370-023-06R1	66.0	30.0	36.0	28.0	6.0
3.8	-	29.0	02897857	SD1105A-0380-029-06R1	74.0	38.0	36.0	36.0	6.0
3.9	-	29.0	02897858	SD1105A-0390-029-06R1	74.0	38.0	36.0	36.0	6.0
3.969	5/32	29.0	02897859	SD1105A-0397-029-06R1	74.0	38.0	36.0	36.0	6.0
4.0	-	29.0	02897860	SD1105A-0400-029-06R1	74.0	38.0	36.0	36.0	6.0
4.1	-	29.0	02897861	SD1105A-0410-029-06R1	74.0	38.0	36.0	36.0	6.0
4.2	-	29.0	02897862	SD1105A-0420-029-06R1	74.0	38.0	36.0	36.0	6.0
4.3	-	29.0	02897863	SD1105A-0430-029-06R1	74.0	38.0	36.0	36.0	6.0
4.4	-	29.0	02897865	SD1105A-0440-029-06R1	74.0	38.0	36.0	36.0	6.0
4.5	-	29.0	02897866	SD1105A-0450-029-06R1	74.0	38.0	36.0	36.0	6.0
4.6	-	29.0	02897867	SD1105A-0460-029-06R1	74.0	38.0	36.0	36.0	6.0
4.65	-	29.0	02897868	SD1105A-0465-029-06R1	74.0	38.0	36.0	36.0	6.0
4.7	-	29.0	02897869	SD1105A-0470-029-06R1	74.0	38.0	36.0	36.0	6.0
4.763	3/16	35.0	02897870	SD1105A-0476-035-06R1	82.0	46.0	36.0	44.0	6.0
4.8	-	35.0	02897871	SD1105A-0480-035-06R1	82.0	46.0	36.0	44.0	6.0
4.9	-	35.0	02897872	SD1105A-0490-035-06R1	82.0	46.0	36.0	44.0	6.0
5.0	-	35.0	02897873	SD1105A-0500-035-06R1	82.0	46.0	36.0	44.0	6.0
5.1	-	35.0	02897874	SD1105A-0510-035-06R1	82.0	46.0	36.0	44.0	6.0
5.159	13/64	35.0	02897875	SD1105A-0516-035-06R1	82.0	46.0	36.0	44.0	6.0
5.2	-	35.0	02897876	SD1105A-0520-035-06R1	82.0	46.0	36.0	44.0	6.0
5.3	-	35.0	02897877	SD1105A-0530-035-06R1	82.0	46.0	36.0	44.0	6.0
5.4	-	35.0	02897878	SD1105A-0540-035-06R1	82.0	46.0	36.0	44.0	6.0
5.5	-	35.0	02897879	SD1105A-0550-035-06R1	82.0	46.0	36.0	44.0	6.0
5.55	-	35.0	02897880	SD1105A-0555-035-06R1	82.0	46.0	36.0	44.0	6.0
5.6	-	35.0	02897882	SD1105A-0560-035-06R1	82.0	46.0	36.0	44.0	6.0
5.7	-	35.0	02897883	SD1105A-0570-035-06R1	82.0	46.0	36.0	44.0	6.0
5.8	-	35.0	02897884	SD1105A-0580-035-06R1	82.0	46.0	36.0	44.0	6.0
5.9	-	35.0	02897885	SD1105A-0590-035-06R1	82.0	46.0	36.0	44.0	6.0
5.953	15/64	35.0	02897886	SD1105A-0595-035-06R1	82.0	46.0	36.0	44.0	6.0

Drilling depth ~ 5 x D

Cylindrical shank DIN 6537A

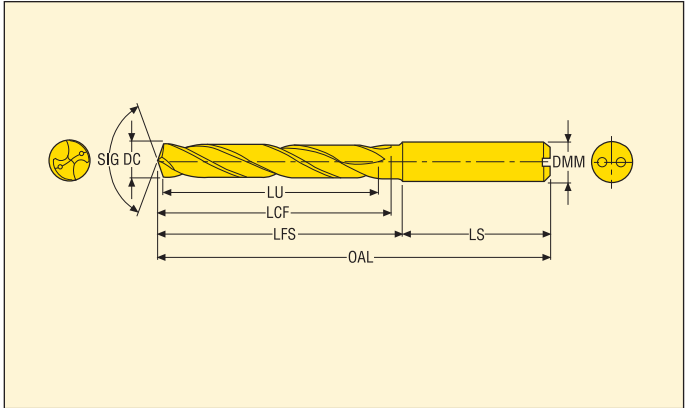

- Internal coolant
- Point angle: 140°
- Coating: AlCrN
- Hole tolerance: IT8-9
- For cutting data see page(s) 101

DC m7 (mm)	DC m7 (inch)	LU	Ordering and Product No.	Designation	Dimensions in mm				
					OAL	LFS	LS	LCF	DMM
6.0	–	35.0	02897887	SD1105A-0600-035-06R1	82.0	46.0	36.0	44.0	6.0
6.1	–	43.0	02897888	SD1105A-0610-043-08R1	91.0	55.0	36.0	53.0	8.0
6.2	–	43.0	02897889	SD1105A-0620-043-08R1	91.0	55.0	36.0	53.0	8.0
6.3	–	43.0	02897890	SD1105A-0630-043-08R1	91.0	55.0	36.0	53.0	8.0
6.35	1/4	43.0	02897891	SD1105A-0635-043-08R1	91.0	55.0	36.0	53.0	8.0
6.4	–	43.0	02897892	SD1105A-0640-043-08R1	91.0	55.0	36.0	53.0	8.0
6.5	–	43.0	02897893	SD1105A-0650-043-08R1	91.0	55.0	36.0	53.0	8.0
6.6	–	43.0	02897894	SD1105A-0660-043-08R1	91.0	55.0	36.0	53.0	8.0
6.7	–	43.0	02897895	SD1105A-0670-043-08R1	91.0	55.0	36.0	53.0	8.0
6.747	17/64	43.0	02897896	SD1105A-0675-043-08R1	91.0	55.0	36.0	53.0	8.0
6.8	–	43.0	02897897	SD1105A-0680-043-08R1	91.0	55.0	36.0	53.0	8.0
6.9	–	43.0	02897898	SD1105A-0690-043-08R1	91.0	55.0	36.0	53.0	8.0
7.0	–	43.0	02897899	SD1105A-0700-043-08R1	91.0	55.0	36.0	53.0	8.0
7.1	–	43.0	02897900	SD1105A-0710-043-08R1	91.0	55.0	36.0	53.0	8.0
7.2	–	43.0	02897902	SD1105A-0720-043-08R1	91.0	55.0	36.0	53.0	8.0
7.3	–	43.0	02897903	SD1105A-0730-043-08R1	91.0	55.0	36.0	53.0	8.0
7.4	–	43.0	02897904	SD1105A-0740-043-08R1	91.0	55.0	36.0	53.0	8.0
7.5	–	43.0	02897905	SD1105A-0750-043-08R1	91.0	55.0	36.0	53.0	8.0
7.541	19/64	43.0	02897906	SD1105A-0754-043-08R1	91.0	55.0	36.0	53.0	8.0
7.55	–	43.0	02897907	SD1105A-0755-043-08R1	91.0	55.0	36.0	53.0	8.0
7.6	–	43.0	02897908	SD1105A-0760-043-08R1	91.0	55.0	36.0	53.0	8.0
7.7	–	43.0	02897909	SD1105A-0770-043-08R1	91.0	55.0	36.0	53.0	8.0
7.8	–	43.0	02897910	SD1105A-0780-043-08R1	91.0	55.0	36.0	53.0	8.0
7.9	–	43.0	02897911	SD1105A-0790-043-08R1	91.0	55.0	36.0	53.0	8.0
7.938	5/16	43.0	02897912	SD1105A-0794-043-08R1	91.0	55.0	36.0	53.0	8.0
8.0	–	43.0	02897913	SD1105A-0800-043-08R1	91.0	55.0	36.0	53.0	8.0
8.1	–	49.0	02897914	SD1105A-0810-049-10R1	103.0	63.0	40.0	61.0	10.0
8.2	–	49.0	02897915	SD1105A-0820-049-10R1	103.0	63.0	40.0	61.0	10.0
8.3	–	49.0	02897916	SD1105A-0830-049-10R1	103.0	63.0	40.0	61.0	10.0
8.4	–	49.0	02897918	SD1105A-0840-049-10R1	103.0	63.0	40.0	61.0	10.0
8.5	–	49.0	02897919	SD1105A-0850-049-10R1	103.0	63.0	40.0	61.0	10.0
8.6	–	49.0	02897920	SD1105A-0860-049-10R1	103.0	63.0	40.0	61.0	10.0
8.7	–	49.0	02897921	SD1105A-0870-049-10R1	103.0	63.0	40.0	61.0	10.0
8.8	–	49.0	02897923	SD1105A-0880-049-10R1	103.0	63.0	40.0	61.0	10.0
8.9	–	49.0	02897924	SD1105A-0890-049-10R1	103.0	63.0	40.0	61.0	10.0
9.0	–	49.0	02897925	SD1105A-0900-049-10R1	103.0	63.0	40.0	61.0	10.0
9.1	–	49.0	02897926	SD1105A-0910-049-10R1	103.0	63.0	40.0	61.0	10.0
9.128	23/64	49.0	02897927	SD1105A-0913-049-10R1	103.0	63.0	40.0	61.0	10.0
9.2	–	49.0	02897928	SD1105A-0920-049-10R1	103.0	63.0	40.0	61.0	10.0

Drilling depth ~ 5 x D

Cylindrical shank DIN 6537A



- Internal coolant
- Point angle: 140°
- Coating: AlCrN
- Hole tolerance: IT8-9
- For cutting data see page(s) 101

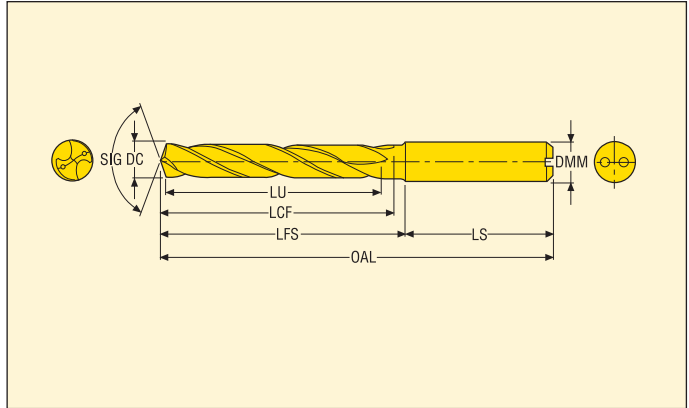

DC m7 (mm)	DC m7 (inch)	LU	Ordering and Product No.	Designation	Dimensions in mm				
					OAL	LFS	LS	LCF	DMM
9,3	-	49,0	02897929	SD1105A-0930-049-10R1	103,0	63,0	40,0	61,0	10,0
9,4	-	49,0	02897930	SD1105A-0940-049-10R1	103,0	63,0	40,0	61,0	10,0
9,5	-	49,0	02897931	SD1105A-0950-049-10R1	103,0	63,0	40,0	61,0	10,0
9,55	-	49,0	02897933	SD1105A-0955-049-10R1	103,0	63,0	40,0	61,0	10,0
9,6	-	49,0	02897934	SD1105A-0960-049-10R1	103,0	63,0	40,0	61,0	10,0
9,7	-	49,0	02897935	SD1105A-0970-049-10R1	103,0	63,0	40,0	61,0	10,0
9,8	-	49,0	02897936	SD1105A-0980-049-10R1	103,0	63,0	40,0	61,0	10,0
9,9	-	49,0	02897937	SD1105A-0990-049-10R1	103,0	63,0	40,0	61,0	10,0
10,0	-	49,0	02897939	SD1105A-1000-049-10R1	103,0	63,0	40,0	61,0	10,0
10,1	-	56,0	02897940	SD1105A-1010-056-12R1	118,0	73,0	45,0	71,0	12,0
10,2	-	56,0	02897941	SD1105A-1020-056-12R1	118,0	73,0	45,0	71,0	12,0
10,3	-	56,0	02897942	SD1105A-1030-056-12R1	118,0	73,0	45,0	71,0	12,0
10,4	-	56,0	02897944	SD1105A-1040-056-12R1	118,0	73,0	45,0	71,0	12,0
10,5	-	56,0	02897945	SD1105A-1050-056-12R1	118,0	73,0	45,0	71,0	12,0
10,6	-	56,0	02897946	SD1105A-1060-056-12R1	118,0	73,0	45,0	71,0	12,0
10,7	-	56,0	02897947	SD1105A-1070-056-12R1	118,0	73,0	45,0	71,0	12,0
10,716	27/64	56,0	02897948	SD1105A-1072-056-12R1	118,0	73,0	45,0	71,0	12,0
10,8	-	56,0	02897949	SD1105A-1080-056-12R1	118,0	73,0	45,0	71,0	12,0
10,9	-	56,0	02897951	SD1105A-1090-056-12R1	118,0	73,0	45,0	71,0	12,0
11,0	-	56,0	02897952	SD1105A-1100-056-12R1	118,0	73,0	45,0	71,0	12,0
11,1	-	56,0	02897953	SD1105A-1110-056-12R1	118,0	73,0	45,0	71,0	12,0
11,2	-	56,0	02897955	SD1105A-1120-056-12R1	118,0	73,0	45,0	71,0	12,0
11,3	-	56,0	02897956	SD1105A-1130-056-12R1	118,0	73,0	45,0	71,0	12,0
11,4	-	56,0	02897957	SD1105A-1140-056-12R1	118,0	73,0	45,0	71,0	12,0
11,5	-	56,0	02897958	SD1105A-1150-056-12R1	118,0	73,0	45,0	71,0	12,0
11,55	-	56,0	02897960	SD1105A-1155-056-12R1	118,0	73,0	45,0	71,0	12,0
11,6	-	56,0	02897961	SD1105A-1160-056-12R1	118,0	73,0	45,0	71,0	12,0
11,7	-	56,0	02897962	SD1105A-1170-056-12R1	118,0	73,0	45,0	71,0	12,0
11,8	-	56,0	02897963	SD1105A-1180-056-12R1	118,0	73,0	45,0	71,0	12,0
11,9	-	56,0	02897964	SD1105A-1190-056-12R1	118,0	73,0	45,0	71,0	12,0
12,0	-	56,0	02897966	SD1105A-1200-056-12R1	118,0	73,0	45,0	71,0	12,0
12,1	-	60,0	02897967	SD1105A-1210-060-14R1	124,0	79,0	45,0	77,0	14,0
12,2	-	60,0	02897968	SD1105A-1220-060-14R1	124,0	79,0	45,0	77,0	14,0
12,25	-	60,0	02897969	SD1105A-1225-060-14R1	124,0	79,0	45,0	77,0	14,0
12,303	31/64	60,0	02897970	SD1105A-1230-060-14R1	124,0	79,0	45,0	77,0	14,0
12,4	-	60,0	02897972	SD1105A-1240-060-14R1	124,0	79,0	45,0	77,0	14,0

Drilling depth ~ 5 x D

Cylindrical shank DIN 6537A

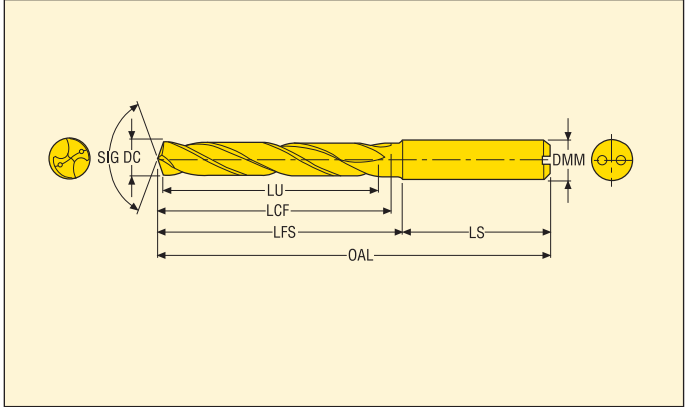

- Internal coolant
- Point angle: 140°
- Coating: AlCrN
- Hole tolerance: IT8-9
- For cutting data see page(s) 101

DC m7 (mm)	DC m7 (inch)	LU	Ordering and Product No.	Designation	Dimensions in mm				
					OAL	LFS	LS	LCF	DMM
12,5	–	60,0	02897973	SD1105A-1250-060-14R1	124,0	79,0	45,0	77,0	14,0
12,6	–	60,0	02897974	SD1105A-1260-060-14R1	124,0	79,0	45,0	77,0	14,0
12,7	1/2	60,0	02897950	SD1105A-1270-060-14R1	124,0	79,0	45,0	77,0	14,0
12,75	–	60,0	02897976	SD1105A-1275-060-14R1	124,0	79,0	45,0	77,0	14,0
12,8	–	60,0	02897977	SD1105A-1280-060-14R1	124,0	79,0	45,0	77,0	14,0
12,9	–	60,0	02897978	SD1105A-1290-060-14R1	124,0	79,0	45,0	77,0	14,0
13,0	–	60,0	02897979	SD1105A-1300-060-14R1	124,0	79,0	45,0	77,0	14,0
13,1	–	60,0	02897980	SD1105A-1310-060-14R1	124,0	79,0	45,0	77,0	14,0
13,2	–	60,0	02897981	SD1105A-1320-060-14R1	124,0	79,0	45,0	77,0	14,0
13,3	–	60,0	02897982	SD1105A-1330-060-14R1	124,0	79,0	45,0	77,0	14,0
13,4	–	60,0	02897983	SD1105A-1340-060-14R1	124,0	79,0	45,0	77,0	14,0
13,5	–	60,0	02897985	SD1105A-1350-060-14R1	124,0	79,0	45,0	77,0	14,0
13,6	–	60,0	02897986	SD1105A-1360-060-14R1	124,0	79,0	45,0	77,0	14,0
13,7	–	60,0	02897987	SD1105A-1370-060-14R1	124,0	79,0	45,0	77,0	14,0
13,8	–	60,0	02897988	SD1105A-1380-060-14R1	124,0	79,0	45,0	77,0	14,0
13,9	–	60,0	02897989	SD1105A-1390-060-14R1	124,0	79,0	45,0	77,0	14,0
14,0	–	60,0	02897990	SD1105A-1400-060-14R1	124,0	79,0	45,0	77,0	14,0
14,1	–	63,0	02897991	SD1105A-1410-063-16R1	133,0	85,0	48,0	83,0	16,0
14,2	–	63,0	02897992	SD1105A-1420-063-16R1	133,0	85,0	48,0	83,0	16,0
14,288	9/16	63,0	02897993	SD1105A-1429-063-16R1	133,0	85,0	48,0	83,0	16,0
14,3	–	63,0	02897994	SD1105A-1430-063-16R1	133,0	85,0	48,0	83,0	16,0
14,4	–	63,0	02897995	SD1105A-1440-063-16R1	133,0	85,0	48,0	83,0	16,0
14,5	–	63,0	02897996	SD1105A-1450-063-16R1	133,0	85,0	48,0	83,0	16,0
14,6	–	63,0	02897997	SD1105A-1460-063-16R1	133,0	85,0	48,0	83,0	16,0
14,7	–	63,0	02897998	SD1105A-1470-063-16R1	133,0	85,0	48,0	83,0	16,0
14,75	–	63,0	02897999	SD1105A-1475-063-16R1	133,0	85,0	48,0	83,0	16,0
14,8	–	63,0	02898000	SD1105A-1480-063-16R1	133,0	85,0	48,0	83,0	16,0
14,9	–	63,0	02898001	SD1105A-1490-063-16R1	133,0	85,0	48,0	83,0	16,0
15,0	–	63,0	02898002	SD1105A-1500-063-16R1	133,0	85,0	48,0	83,0	16,0
15,1	–	63,0	02898003	SD1105A-1510-063-16R1	133,0	85,0	48,0	83,0	16,0
15,2	–	63,0	02898004	SD1105A-1520-063-16R1	133,0	85,0	48,0	83,0	16,0
15,3	–	63,0	02898005	SD1105A-1530-063-16R1	133,0	85,0	48,0	83,0	16,0
15,4	–	63,0	02898006	SD1105A-1540-063-16R1	133,0	85,0	48,0	83,0	16,0
15,5	–	63,0	02898007	SD1105A-1550-063-16R1	133,0	85,0	48,0	83,0	16,0
15,6	–	63,0	02898008	SD1105A-1560-063-16R1	133,0	85,0	48,0	83,0	16,0
15,7	–	63,0	02898009	SD1105A-1570-063-16R1	133,0	85,0	48,0	83,0	16,0
15,8	–	63,0	02898010	SD1105A-1580-063-16R1	133,0	85,0	48,0	83,0	16,0
15,9	–	63,0	02898012	SD1105A-1590-063-16R1	133,0	85,0	48,0	83,0	16,0
16,0	–	63,0	02898013	SD1105A-1600-063-16R1	133,0	85,0	48,0	83,0	16,0
16,1	–	71,0	02898014	SD1105A-1610-071-18R1	143,0	95,0	48,0	93,0	18,0

Drilling depth ~ 5 x D

Cylindrical shank DIN 6537A



- Internal coolant
- Point angle: 140°
- Coating: AlCrN
- Hole tolerance: IT8-9
- For cutting data see page(s) 101

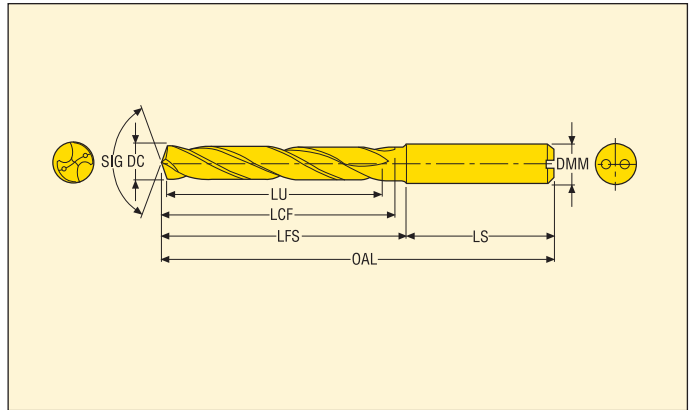

DC m7 (mm)	DC m7 (inch)	LU	Ordering and Product No.	Designation	Dimensions in mm				
					OAL	LFS	LS	LCF	DMM
16,2	-	71,0	02898015	SD1105A-1620-071-18R1	143,0	95,0	48,0	93,0	18,0
16,3	-	71,0	02898016	SD1105A-1630-071-18R1	143,0	95,0	48,0	93,0	18,0
16,4	-	71,0	02898017	SD1105A-1640-071-18R1	143,0	95,0	48,0	93,0	18,0
16,5	-	71,0	02898018	SD1105A-1650-071-18R1	143,0	95,0	48,0	93,0	18,0
16,6	-	71,0	02898019	SD1105A-1660-071-18R1	143,0	95,0	48,0	93,0	18,0
16,7	-	71,0	02898020	SD1105A-1670-071-18R1	143,0	95,0	48,0	93,0	18,0
16,75	-	71,0	02898021	SD1105A-1675-071-18R1	143,0	95,0	48,0	93,0	18,0
16,8	-	71,0	02898022	SD1105A-1680-071-18R1	143,0	95,0	48,0	93,0	18,0
16,9	-	71,0	02898023	SD1105A-1690-071-18R1	143,0	95,0	48,0	93,0	18,0
17,0	-	71,0	02898024	SD1105A-1700-071-18R1	143,0	95,0	48,0	93,0	18,0
17,1	-	71,0	02898025	SD1105A-1710-071-18R1	143,0	95,0	48,0	93,0	18,0
17,2	-	71,0	02898026	SD1105A-1720-071-18R1	143,0	95,0	48,0	93,0	18,0
17,3	-	71,0	02898027	SD1105A-1730-071-18R1	143,0	95,0	48,0	93,0	18,0
17,4	-	71,0	02898028	SD1105A-1740-071-18R1	143,0	95,0	48,0	93,0	18,0
17,5	-	71,0	02898029	SD1105A-1750-071-18R1	143,0	95,0	48,0	93,0	18,0
17,6	-	71,0	02898030	SD1105A-1760-071-18R1	143,0	95,0	48,0	93,0	18,0
17,7	-	71,0	02898031	SD1105A-1770-071-18R1	143,0	95,0	48,0	93,0	18,0
17,8	-	71,0	02898032	SD1105A-1780-071-18R1	143,0	95,0	48,0	93,0	18,0
17,9	-	71,0	02898033	SD1105A-1790-071-18R1	143,0	95,0	48,0	93,0	18,0
18,0	-	71,0	02898034	SD1105A-1800-071-18R1	143,0	95,0	48,0	93,0	18,0
18,1	-	77,0	02898035	SD1105A-1810-077-20R1	153,0	103,0	50,0	101,0	20,0
18,2	-	77,0	02898036	SD1105A-1820-077-20R1	153,0	103,0	50,0	101,0	20,0
18,3	-	77,0	02898037	SD1105A-1830-077-20R1	153,0	103,0	50,0	101,0	20,0
18,4	-	77,0	02898038	SD1105A-1840-077-20R1	153,0	103,0	50,0	101,0	20,0
18,5	-	77,0	02898039	SD1105A-1850-077-20R1	153,0	103,0	50,0	101,0	20,0
18,6	-	77,0	02898040	SD1105A-1860-077-20R1	153,0	103,0	50,0	101,0	20,0
18,7	-	77,0	02898041	SD1105A-1870-077-20R1	153,0	103,0	50,0	101,0	20,0
18,8	-	77,0	02898042	SD1105A-1880-077-20R1	153,0	103,0	50,0	101,0	20,0
18,9	-	77,0	02898043	SD1105A-1890-077-20R1	153,0	103,0	50,0	101,0	20,0
19,0	-	77,0	02898044	SD1105A-1900-077-20R1	153,0	103,0	50,0	101,0	20,0
19,1	-	77,0	02898046	SD1105A-1910-077-20R1	153,0	103,0	50,0	101,0	20,0
19,2	-	77,0	02898047	SD1105A-1920-077-20R1	153,0	103,0	50,0	101,0	20,0
19,3	-	77,0	02898048	SD1105A-1930-077-20R1	153,0	103,0	50,0	101,0	20,0
19,4	-	77,0	02898049	SD1105A-1940-077-20R1	153,0	103,0	50,0	101,0	20,0
19,5	-	77,0	02898050	SD1105A-1950-077-20R1	153,0	103,0	50,0	101,0	20,0
19,6	-	77,0	02898051	SD1105A-1960-077-20R1	153,0	103,0	50,0	101,0	20,0
19,7	-	77,0	02898052	SD1105A-1970-077-20R1	153,0	103,0	50,0	101,0	20,0
19,8	-	77,0	02898053	SD1105A-1980-077-20R1	153,0	103,0	50,0	101,0	20,0
19,9	-	77,0	02898054	SD1105A-1990-077-20R1	153,0	103,0	50,0	101,0	20,0
20,0	-	77,0	02898055	SD1105A-2000-077-20R1	153,0	103,0	50,0	101,0	20,0

Drilling depth ~ 3 x D – Metric

Cylindrical shank DIN 6537A

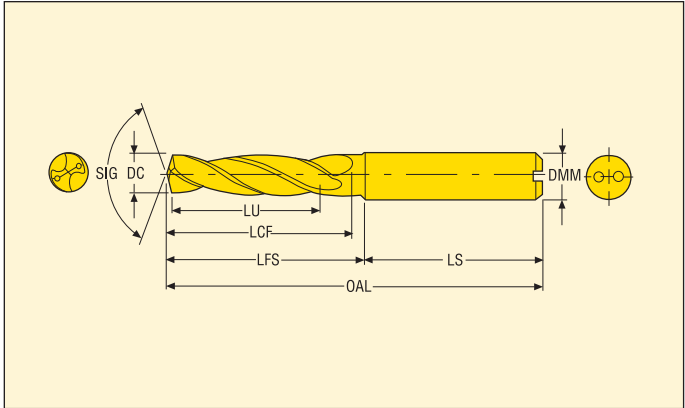

- Internal coolant
- Point angle: 140°
- Coating: TiAlN
- Hole tolerance: IT8-9
- For cutting data see page(s) 102

DC m7 (mm)	LU	Ordering and Product No.	Designation	Dimensions in mm				
				OAL	LFS	LS	LCF	DMM
2.0	7	03045918	SD203A-0200-007-04R1-P	41	14	27	11	4
2.1	7	03045919	SD203A-0210-007-04R1-P	41	14	27	11	4
2.2	7	03045920	SD203A-0220-007-04R1-P	41	14	27	11	4
2.3	8	03045921	SD203A-0230-008-04R1-P	44	17	27	13	4
2,35	8	03138154	SD203A-0235-008-04R1-P	44	17	27	13	4
2,381	8	03120476	SD203A-0238-008-04R1-P	44	17	27	13	4
2.4	8	03045922	SD203A-0240-008-04R1-P	44	17	27	13	4
2.5	8	03045923	SD203A-0250-008-04R1-P	44	17	27	13	4
2.6	8	03045924	SD203A-0260-008-04R1-P	44	17	27	13	4
2.7	9	03045925	SD203A-0270-009-04R1-P	44	17	27	15	4
2,778	9	03120495	SD203A-0278-009-04R1-P	44	17	27	15	4
2.8	9	03045926	SD203A-0280-009-04R1-P	44	17	27	15	4
2.9	9	03045927	SD203A-0290-009-04R1-P	44	17	27	15	4
3.0	14	03045928	SD203A-0300-014-06R1-P	62	26	36	20	6
3.1	14	03045929	SD203A-0310-014-06R1-P	62	26	36	20	6
3,175	14	03046061	SD203A-0318-014-06R1-P	62	26	36	20	6
3.2	14	03045930	SD203A-0320-014-06R1-P	62	26	36	20	6
3,25	14	03045931	SD203A-0325-014-06R1-P	62	26	36	20	6
3.3	14	03045932	SD203A-0330-014-06R1-P	62	26	36	20	6
3.4	14	03045933	SD203A-0340-014-06R1-P	62	26	36	20	6
3.5	14	03045934	SD203A-0350-014-06R1-P	62	26	36	20	6
3,572	14	03046062	SD203A-0357-014-06R1-P	62	26	36	20	6
3.6	14	03045935	SD203A-0360-014-06R1-P	62	26	36	20	6
3,65	14	03045936	SD203A-0365-014-06R1-P	62	26	36	20	6
3.7	14	03045937	SD203A-0370-014-06R1-P	62	26	36	20	6
3.8	17	03045938	SD203A-0380-017-06R1-P	66	30	36	24	6
3.9	17	03045939	SD203A-0390-017-06R1-P	66	30	36	24	6
3,97	17	03046063	SD203A-0397-017-06R1-P	66	30	36	24	6
4.0	17	03045940	SD203A-0400-017-06R1-P	66	30	36	24	6
4.1	17	03045941	SD203A-0410-017-06R1-P	66	30	36	24	6
4.2	17	03045942	SD203A-0420-017-06R1-P	66	30	36	24	6
4.3	17	03045943	SD203A-0430-017-06R1-P	66	30	36	24	6
4,366	17	03046064	SD203A-0437-017-06R1-P	66	30	36	24	6
4.5	17	03045944	SD203A-0450-017-06R1-P	66	30	36	24	6
4.6	17	03045945	SD203A-0460-017-06R1-P	66	30	36	24	6
4,65	17	03045946	SD203A-0465-017-06R1-P	66	30	36	24	6
4.7	17	03045947	SD203A-0470-017-06R1-P	66	30	36	24	6
4,763	20	03046065	SD203A-0476-020-06R1-P	66	30	36	28	6
4.8	20	03045948	SD203A-0480-020-06R1-P	66	30	36	28	6
4.9	20	03045949	SD203A-0490-020-06R1-P	66	30	36	28	6
5.0	20	03045950	SD203A-0500-020-06R1-P	66	30	36	28	6
5.1	20	03045951	SD203A-0510-020-06R1-P	66	30	36	28	6

For intermediate diameters see the MyDesign software.

Drilling depth ~ 3 x D – Metric

Cylindrical shank DIN 6537A

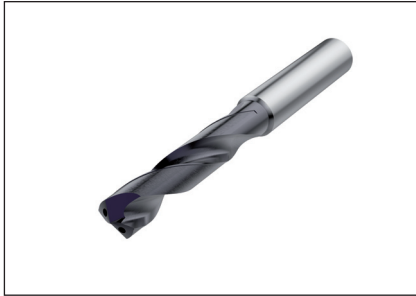

- Internal coolant
- Point angle: 140°
- Coating: TiAlN
- Hole tolerance: IT8-9
- For cutting data see page(s) 102

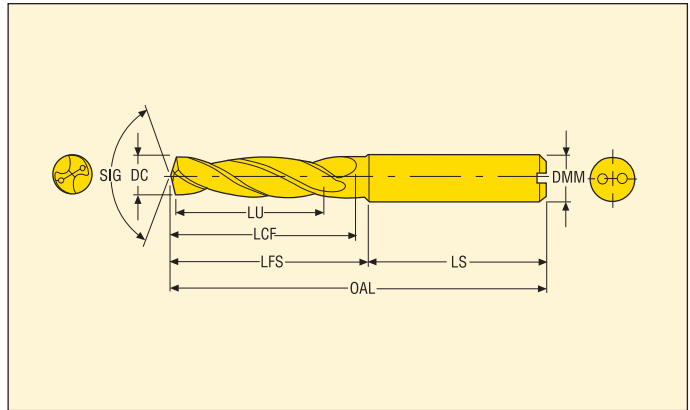

DC m7 (mm)	LU	Ordering and Product No.	Designation	Dimensions in mm				
				OAL	LFS	LS	LCF	DMM
5,159	20	03046066	SD203A-0516-020-06R1-P	66	30	36	28	6
5,2	20	03045952	SD203A-0520-020-06R1-P	66	30	36	28	6
5,3	20	03045953	SD203A-0530-020-06R1-P	66	30	36	28	6
5,4	20	03045954	SD203A-0540-020-06R1-P	66	30	36	28	6
5,5	20	03045955	SD203A-0550-020-06R1-P	66	30	36	28	6
5,55	20	03045956	SD203A-0555-020-06R1-P	66	30	36	28	6
5,556	20	03046067	SD203A-0556-020-06R1-P	66	30	36	28	6
5,6	20	03045957	SD203A-0560-020-06R1-P	66	30	36	28	6
5,7	20	03045958	SD203A-0570-020-06R1-P	66	30	36	28	6
5,8	20	03045959	SD203A-0580-020-06R1-P	66	30	36	28	6
5,9	20	03045960	SD203A-0590-020-06R1-P	66	30	36	28	6
5,953	20	03046068	SD203A-0595-020-06R1-P	66	30	36	28	6
6,0	20	03045961	SD203A-0600-020-06R1-P	66	30	36	28	6
6,1	24	03045962	SD203A-0610-024-08R1-P	79	43	36	34	8
6,2	24	03045963	SD203A-0620-024-08R1-P	79	43	36	34	8
6,3	24	03045964	SD203A-0630-024-08R1-P	79	43	36	34	8
6,35	24	03046069	SD203A-0635-024-08R1-P	79	43	36	34	8
6,4	24	03045965	SD203A-0640-024-08R1-P	79	43	36	34	8
6,5	24	03045966	SD203A-0650-024-08R1-P	79	43	36	34	8
6,6	24	03045967	SD203A-0660-024-08R1-P	79	43	36	34	8
6,7	24	03045968	SD203A-0670-024-08R1-P	79	43	36	34	8
6,747	24	03046070	SD203A-0675-024-08R1-P	79	43	36	34	8
6,8	24	03045969	SD203A-0680-024-08R1-P	79	43	36	34	8
6,9	24	03045970	SD203A-0690-024-08R1-P	79	43	36	34	8
7,0	24	03045971	SD203A-0700-024-08R1-P	79	43	36	34	8
7,1	29	03045972	SD203A-0710-029-08R1-P	79	43	36	41	8
7,144	29	03046071	SD203A-0714-029-08R1-P	79	43	36	41	8
7,2	29	03045973	SD203A-0720-029-08R1-P	79	43	36	41	8
7,3	29	03045974	SD203A-0730-029-08R1-P	79	43	36	41	8
7,4	29	03045975	SD203A-0740-029-08R1-P	79	43	36	41	8
7,5	29	03045976	SD203A-0750-029-08R1-P	79	43	36	41	8
7,541	29	03046072	SD203A-0754-029-08R1-P	79	43	36	41	8
7,55	29	03045977	SD203A-0755-029-08R1-P	79	43	36	41	8
7,6	29	03045978	SD203A-0760-029-08R1-P	79	43	36	41	8
7,7	29	03045979	SD203A-0770-029-08R1-P	79	43	36	41	8
7,8	29	03045980	SD203A-0780-029-08R1-P	79	43	36	41	8
7,9	29	03045981	SD203A-0790-029-08R1-P	79	43	36	41	8
7,938	29	03046073	SD203A-0794-029-08R1-P	79	43	36	41	8
8,0	29	03045982	SD203A-0800-029-08R1-P	79	43	36	41	8
8,1	35	03045983	SD203A-0810-035-10R1-P	89	49	40	47	10
8,2	35	03045984	SD203A-0820-035-10R1-P	89	49	40	47	10
8,3	35	03045985	SD203A-0830-035-10R1-P	89	49	40	47	10

For intermediate diameters see the MyDesign software.

Drilling depth ~ 3 x D – Metric

Cylindrical shank DIN 6537A



- Internal coolant
- Point angle: 140°
- Coating: TiAlN
- Hole tolerance: IT8-9
- For cutting data see page(s) 102-103

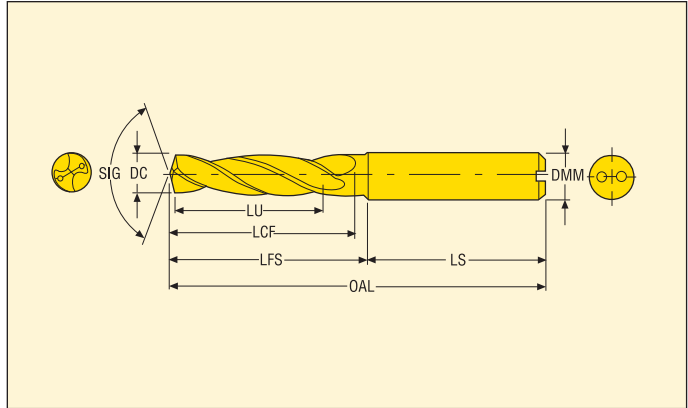

DC m7 (mm)	LU	Ordering and Product No.	Designation	Dimensions in mm				
				OAL	LFS	LS	LCF	DMM
8,334	35	03046074	SD203A-0833-035-10R1-P	89	49	40	47	10
8,4	35	03045986	SD203A-0840-035-10R1-P	89	49	40	47	10
8,5	35	03045987	SD203A-0850-035-10R1-P	89	49	40	47	10
8,6	35	03045988	SD203A-0860-035-10R1-P	89	49	40	47	10
8,7	35	03045989	SD203A-0870-035-10R1-P	89	49	40	47	10
8,731	35	03046075	SD203A-0873-035-10R1-P	89	49	40	47	10
8,8	35	03045990	SD203A-0880-035-10R1-P	89	49	40	47	10
8,9	35	03045991	SD203A-0890-035-10R1-P	89	49	40	47	10
9,0	35	03045992	SD203A-0900-035-10R1-P	89	49	40	47	10
9,1	35	03045993	SD203A-0910-035-10R1-P	89	49	40	47	10
9,128	35	03046076	SD203A-0913-035-10R1-P	89	49	40	47	10
9,2	35	03045994	SD203A-0920-035-10R1-P	89	49	40	47	10
9,3	35	03045995	SD203A-0930-035-10R1-P	89	49	40	47	10
9,4	35	03045996	SD203A-0940-035-10R1-P	89	49	40	47	10
9,5	35	03045997	SD203A-0950-035-10R1-P	89	49	40	47	10
9,525	35	03046077	SD203A-0953-035-10R1-P	89	49	40	47	10
9,55	35	03045998	SD203A-0955-035-10R1-P	89	49	40	47	10
9,6	35	03045999	SD203A-0960-035-10R1-P	89	49	40	47	10
9,7	35	03046000	SD203A-0970-035-10R1-P	89	49	40	47	10
9,8	35	03046001	SD203A-0980-035-10R1-P	89	49	40	47	10
9,9	35	03046002	SD203A-0990-035-10R1-P	89	49	40	47	10
9,922	35	03046078	SD203A-0992-035-10R1-P	89	49	40	47	10
10,0	35	03046003	SD203A-1000-035-10R1-P	89	49	40	47	10
10,2	40	03046004	SD203A-1020-040-12R1-P	102	57	45	55	12
10,319	40	03046079	SD203A-1032-040-12R1-P	102	57	45	55	12
10,4	40	03046005	SD203A-1040-040-12R1-P	102	57	45	55	12
10,5	40	03046006	SD203A-1050-040-12R1-P	102	57	45	55	12
10,6	40	03046007	SD203A-1060-040-12R1-P	102	57	45	55	12
10,716	40	03046080	SD203A-1072-040-12R1-P	102	57	45	55	12
10,8	40	03046008	SD203A-1080-040-12R1-P	102	57	45	55	12
10,9	40	03046009	SD203A-1090-040-12R1-P	102	57	45	55	12
11,0	40	03046010	SD203A-1100-040-12R1-P	102	57	45	55	12
11,1	40	03046011	SD203A-1110-040-12R1-P	102	57	45	55	12
11,113	40	03046081	SD203A-1111-040-12R1-P	102	57	45	55	12
11,2	40	03046012	SD203A-1120-040-12R1-P	102	57	45	55	12
11,3	40	03046013	SD203A-1130-040-12R1-P	102	57	45	55	12
11,4	40	03046014	SD203A-1140-040-12R1-P	102	57	45	55	12
11,5	40	03046015	SD203A-1150-040-12R1-P	102	57	45	55	12
11,509	40	03046082	SD203A-1151-040-12R1-P	102	57	45	55	12
11,55	40	03046016	SD203A-1155-040-12R1-P	102	57	45	55	12
11,6	40	03046017	SD203A-1160-040-12R1-P	102	57	45	55	12
11,7	40	03046018	SD203A-1170-040-12R1-P	102	57	45	55	12

For intermediate diameters see the MyDesign software.

Drilling depth ~ 3 x D – Metric

Cylindrical shank DIN 6537A



- Internal coolant
- Point angle: 140°
- Coating: TiAlN
- Hole tolerance: IT8-9
- For cutting data see page(s) 102-103

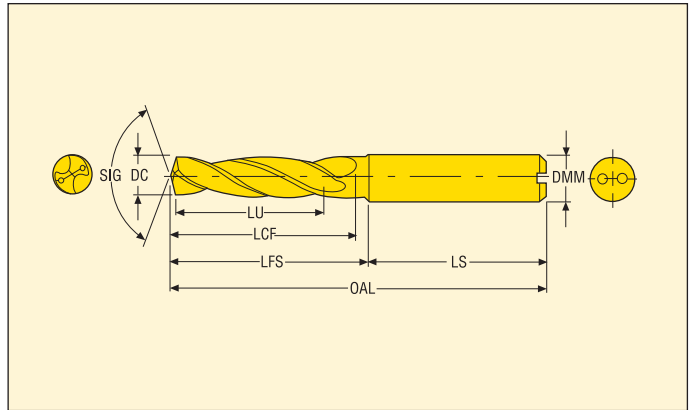

DC m7 (mm)	LU	Ordering and Product No.	Designation	Dimensions in mm				
				OAL	LFS	LS	LCF	DMM
11,8	40	03046019	SD203A-1180-040-12R1-P	102	57	45	55	12
11,9	40	03046020	SD203A-1190-040-12R1-P	102	57	45	55	12
11,906	40	03046083	SD203A-1191-040-12R1-P	102	57	45	55	12
12,0	40	03046021	SD203A-1200-040-12R1-P	102	57	45	55	12
12,1	43	03046022	SD203A-1210-043-14R1-P	107	62	45	60	14
12,2	43	03046023	SD203A-1220-043-14R1-P	107	62	45	60	14
12,303	43	03046084	SD203A-1230-043-14R1-P	107	62	45	60	14
12,4	43	03046024	SD203A-1240-043-14R1-P	107	62	45	60	14
12,5	43	03046025	SD203A-1250-043-14R1-P	107	62	45	60	14
12,6	43	03046026	SD203A-1260-043-14R1-P	107	62	45	60	14
12,7	43	03046085	SD203A-1270-043-14R1-P	107	62	45	60	14
12,75	43	03046027	SD203A-1275-043-14R1-P	107	62	45	60	14
12,8	43	03046028	SD203A-1280-043-14R1-P	107	62	45	60	14
12,9	43	03046029	SD203A-1290-043-14R1-P	107	62	45	60	14
13,0	43	03046030	SD203A-1300-043-14R1-P	107	62	45	60	14
13,1	43	03046031	SD203A-1310-043-14R1-P	107	62	45	60	14
13,2	43	03046032	SD203A-1320-043-14R1-P	107	62	45	60	14
13,3	43	03046033	SD203A-1330-043-14R1-P	107	62	45	60	14
13,4	43	03046034	SD203A-1340-043-14R1-P	107	62	45	60	14
13,494	43	03046086	SD203A-1349-043-14R1-P	107	62	45	60	14
13,5	43	03046035	SD203A-1350-043-14R1-P	107	62	45	60	14
13,6	43	03046036	SD203A-1360-043-14R1-P	107	62	45	60	14
13,7	43	03046037	SD203A-1370-043-14R1-P	107	62	45	60	14
13,8	43	03046038	SD203A-1380-043-14R1-P	107	62	45	60	14
13,9	43	03046039	SD203A-1390-043-14R1-P	107	62	45	60	14
14,0	43	03046040	SD203A-1400-043-14R1-P	107	62	45	60	14
14,2	45	03046041	SD203A-1420-045-16R1-P	115	67	48	65	16
14,25	45	03138155	SD203A-1425-045-16R1-P	115	67	48	65	16
14,288	45	03046087	SD203A-1429-045-16R1-P	115	67	48	65	16
14,5	45	03046042	SD203A-1450-045-16R1-P	115	67	48	65	16
14,7	45	03046043	SD203A-1470-045-16R1-P	115	67	48	65	16
14,75	45	03046044	SD203A-1475-045-16R1-P	115	67	48	65	16
14,8	45	03046045	SD203A-1480-045-16R1-P	115	67	48	65	16
15,0	45	03046046	SD203A-1500-045-16R1-P	115	67	48	65	16
15,1	45	03046047	SD203A-1510-045-16R1-P	115	67	48	65	16
15,3	45	03046048	SD203A-1530-045-16R1-P	115	67	48	65	16
15,5	45	03046049	SD203A-1550-045-16R1-P	115	67	48	65	16
15,7	45	03046050	SD203A-1570-045-16R1-P	115	67	48	65	16
15,8	45	03046051	SD203A-1580-045-16R1-P	115	67	48	65	16
15,875	45	03046088	SD203A-1588-045-16R1-P	115	67	48	65	16
16,0	45	03046052	SD203A-1600-045-16R1-P	115	67	48	65	16
16,5	51	03046053	SD203A-1650-051-18R1-P	123	75	48	73	18

For intermediate diameters see the MyDesign software.

Drilling depth ~ 3 x D – Metric

Cylindrical shank DIN 6537A



- Internal coolant
- Point angle: 140°
- Coating: TiAlN
- Hole tolerance: IT8-9
- For cutting data see page(s) 103

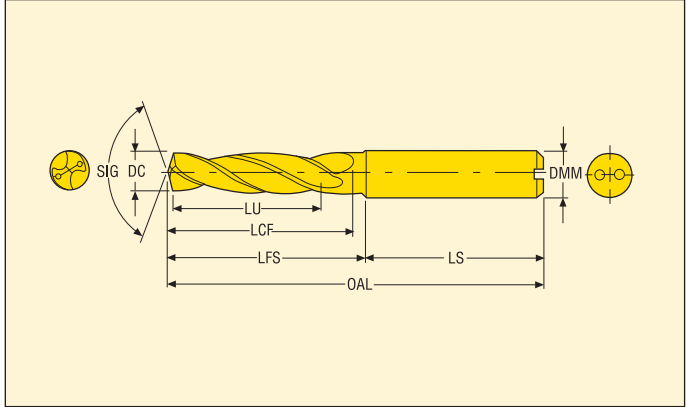

DC m7 (mm)	LU	Ordering and Product No.	Designation	Dimensions in mm				
				OAL	LFS	LS	LCF	DMM
17,0	51	03046054	SD203A-1700-051-18R1-P	123	75	48	73	18
17,5	51	03046055	SD203A-1750-051-18R1-P	123	75	48	73	18
18,0	51	03046056	SD203A-1800-051-18R1-P	123	75	48	73	18
18,5	55	03046057	SD203A-1850-055-20R1-P	131	81	50	79	20
19,0	55	03046058	SD203A-1900-055-20R1-P	131	81	50	79	20
19,05	55	03046089	SD203A-1905-055-20R1-P	131	81	50	79	20
19,5	55	03046059	SD203A-1950-055-20R1-P	131	81	50	79	20
19,8	55	03138156	SD203A-1980-055-20R1-P	131	81	50	79	20
20,0	55	03046060	SD203A-2000-055-20R1-P	131	81	50	79	20

For intermediate diameters see the MyDesign software.

Drilling depth ~ 5 x D – Metric

Cylindrical shank DIN 6537A



- Internal coolant
- Point angle: 140°
- Coating: TiAlN
- Hole tolerance: IT8-9
- For cutting data see page(s) 104

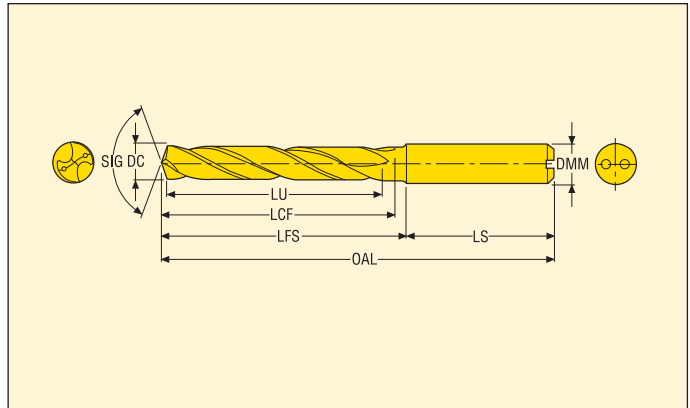

DC m7 (mm)	LU	Ordering and Product No.	Designation	Dimensions in mm				
				OAL	LFS	LS	LCF	DMM
2,0	12	03046131	SD205A-0200-012-04R1-P	46	19	27	15	4
2,1	12	03046132	SD205A-0210-012-04R1-P	46	19	27	15	4
2,2	12	03046133	SD205A-0220-012-04R1-P	46	19	27	15	4
2,3	12	03046134	SD205A-0230-012-04R1-P	46	19	27	15	4
2,381	13	03120477	SD205A-0238-013-04R1-P	50	23	27	18	4
2,4	13	03046135	SD205A-0240-013-04R1-P	50	23	27	18	4
2,5	13	03046136	SD205A-0250-013-04R1-P	50	23	27	18	4
2,6	13	03046137	SD205A-0260-013-04R1-P	50	23	27	18	4
2,7	15	03046138	SD205A-0270-015-04R1-P	50	23	27	21	4
2,778	15	03120496	SD205A-0278-015-04R1-P	50	23	27	21	4
2,8	15	03046139	SD205A-0280-015-04R1-P	50	23	27	21	4
2,9	15	03046141	SD205A-0290-015-04R1-P	50	23	27	21	4
3,0	23	03046142	SD205A-0300-023-06R1-P	66	30	36	26	6
3,1	23	03046143	SD205A-0310-023-06R1-P	66	30	36	26	6
3,175	23	03046327	SD205A-0318-023-06R1-P	66	30	36	26	6
3,2	23	03046144	SD205A-0320-023-06R1-P	66	30	36	26	6
3,25	23	03046145	SD205A-0325-023-06R1-P	66	30	36	26	6
3,3	23	03046146	SD205A-0330-023-06R1-P	66	30	36	26	6
3,4	23	03046147	SD205A-0340-023-06R1-P	66	30	36	26	6
3,5	23	03046148	SD205A-0350-023-06R1-P	66	30	36	26	6
3,572	23	03046328	SD205A-0357-023-06R1-P	66	30	36	26	6
3,6	23	03046149	SD205A-0360-023-06R1-P	66	30	36	26	6
3,65	23	03046150	SD205A-0365-023-06R1-P	66	30	36	26	6
3,7	23	03046151	SD205A-0370-023-06R1-P	66	30	36	26	6
3,8	29	03046152	SD205A-0380-029-06R1-P	74	38	36	34	6
3,9	29	03046153	SD205A-0390-029-06R1-P	74	38	36	34	6
3,97	29	03046329	SD205A-0397-029-06R1-P	74	38	36	34	6
4,0	29	03046154	SD205A-0400-029-06R1-P	74	38	36	34	6
4,1	29	03046155	SD205A-0410-029-06R1-P	74	38	36	34	6
4,2	29	03046157	SD205A-0420-029-06R1-P	74	38	36	34	6
4,3	29	03046158	SD205A-0430-029-06R1-P	74	38	36	34	6
4,366	29	03046330	SD205A-0437-029-06R1-P	74	38	36	34	6
4,4	29	03046159	SD205A-0440-029-06R1-P	74	38	36	34	6
4,5	29	03046160	SD205A-0450-029-06R1-P	74	38	36	34	6
4,6	29	03046161	SD205A-0460-029-06R1-P	74	38	36	34	6
4,65	29	03046162	SD205A-0465-029-06R1-P	74	38	36	34	6
4,7	29	03046163	SD205A-0470-029-06R1-P	74	38	36	34	6
4,763	35	03046331	SD205A-0476-035-06R1-P	82	46	36	44	6
4,8	35	03046164	SD205A-0480-035-06R1-P	82	46	36	44	6
4,9	35	03046165	SD205A-0490-035-06R1-P	82	46	36	44	6
5,0	35	03046166	SD205A-0500-035-06R1-P	82	46	36	44	6
5,1	35	03046167	SD205A-0510-035-06R1-P	82	46	36	44	6

For intermediate diameters see the MyDesign software.

Drilling depth ~ 5 x D – Metric

Cylindrical shank DIN 6537A

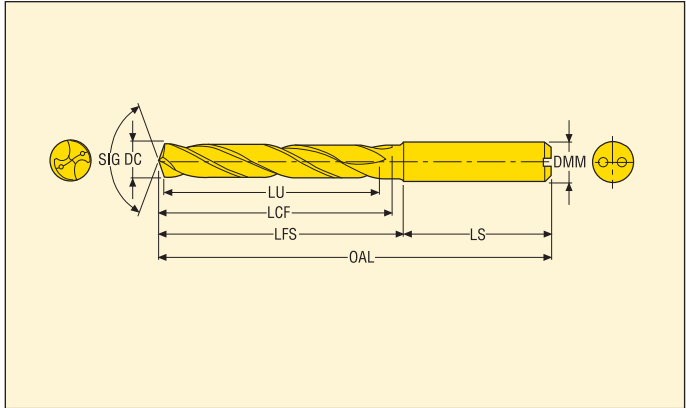

- Internal coolant
- Point angle: 140°
- Coating: TiAlN
- Hole tolerance: IT8-9
- For cutting data see page(s) 104-105

DC m7 (mm)	LU	Ordering and Product No.	Designation	Dimensions in mm				
				OAL	LFS	LS	LCF	DMM
5,159	35	03046332	SD205A-0516-035-06R1-P	82	46	36	44	6
5,2	35	03046168	SD205A-0520-035-06R1-P	82	46	36	44	6
5,3	35	03046169	SD205A-0530-035-06R1-P	82	46	36	44	6
5,4	35	03046170	SD205A-0540-035-06R1-P	82	46	36	44	6
5,5	35	03046171	SD205A-0550-035-06R1-P	82	46	36	44	6
5,55	35	03046172	SD205A-0555-035-06R1-P	82	46	36	44	6
5,556	35	03046333	SD205A-0556-035-06R1-P	82	46	36	44	6
5,6	35	03046173	SD205A-0560-035-06R1-P	82	46	36	44	6
5,7	35	03046174	SD205A-0570-035-06R1-P	82	46	36	44	6
5,8	35	03046175	SD205A-0580-035-06R1-P	82	46	36	44	6
5,9	35	03046176	SD205A-0590-035-06R1-P	82	46	36	44	6
5,953	35	03046334	SD205A-0595-035-06R1-P	82	46	36	44	6
6,0	35	03046177	SD205A-0600-035-06R1-P	82	46	36	44	6
6,1	43	03046179	SD205A-0610-043-08R1-P	91	55	36	53	8
6,2	43	03046180	SD205A-0620-043-08R1-P	91	55	36	53	8
6,3	43	03046181	SD205A-0630-043-08R1-P	91	55	36	53	8
6,35	43	03046335	SD205A-0635-043-08R1-P	91	55	36	53	8
6,4	43	03046182	SD205A-0640-043-08R1-P	91	55	36	53	8
6,5	43	03046183	SD205A-0650-043-08R1-P	91	55	36	53	8
6,6	43	03046184	SD205A-0660-043-08R1-P	91	55	36	53	8
6,7	43	03046185	SD205A-0670-043-08R1-P	91	55	36	53	8
6,747	43	03046336	SD205A-0675-043-08R1-P	91	55	36	53	8
6,8	43	03046186	SD205A-0680-043-08R1-P	91	55	36	53	8
6,9	43	03046187	SD205A-0690-043-08R1-P	91	55	36	53	8
7,0	43	03046188	SD205A-0700-043-08R1-P	91	55	36	53	8
7,1	43	03046190	SD205A-0710-043-08R1-P	91	55	36	53	8
7,144	43	03046337	SD205A-0714-043-08R1-P	91	55	36	53	8
7,2	43	03046191	SD205A-0720-043-08R1-P	91	55	36	53	8
7,3	43	03046192	SD205A-0730-043-08R1-P	91	55	36	53	8
7,4	43	03046193	SD205A-0740-043-08R1-P	91	55	36	53	8
7,5	43	03046194	SD205A-0750-043-08R1-P	91	55	36	53	8
7,541	43	03046338	SD205A-0754-043-08R1-P	91	55	36	53	8
7,55	43	03046195	SD205A-0755-043-08R1-P	91	55	36	53	8
7,6	43	03046196	SD205A-0760-043-08R1-P	91	55	36	53	8
7,7	43	03046197	SD205A-0770-043-08R1-P	91	55	36	53	8
7,8	43	03046198	SD205A-0780-043-08R1-P	91	55	36	53	8
7,9	43	03046199	SD205A-0790-043-08R1-P	91	55	36	53	8
7,938	43	03046339	SD205A-0794-043-08R1-P	91	55	36	53	8
8,0	43	03046200	SD205A-0800-043-08R1-P	91	55	36	53	8
8,1	49	03046201	SD205A-0810-049-10R1-P	103	63	40	61	10
8,2	49	03046202	SD205A-0820-049-10R1-P	103	63	40	61	10
8,3	49	03046203	SD205A-0830-049-10R1-P	103	63	40	61	10

For intermediate diameters see the MyDesign software.

Drilling depth ~ 5 x D – Metric

Cylindrical shank DIN 6537A



- Internal coolant
- Point angle: 140°
- Coating: TiAlN
- Hole tolerance: IT8-9
- For cutting and machining data see page(s) 104-105

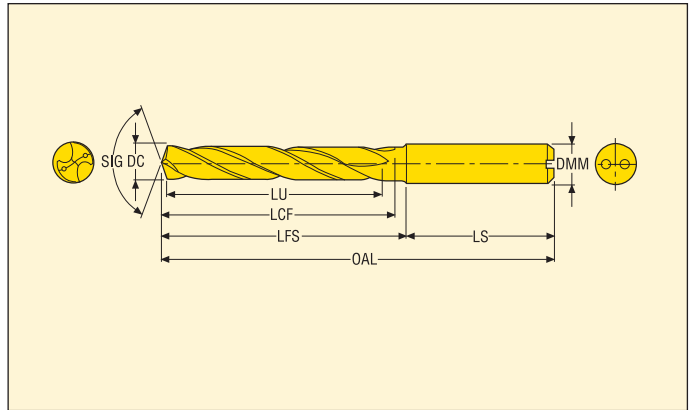

DC m7 (mm)	LU	Ordering and Product No.	Designation	Dimensions in mm				
				OAL	LFS	LS	LCF	DMM
8,334	49	03046340	SD205A-0833-049-10R1-P	103	63	40	61	10
8,4	49	03046204	SD205A-0840-049-10R1-P	103	63	40	61	10
8,5	49	03046205	SD205A-0850-049-10R1-P	103	63	40	61	10
8,6	49	03046206	SD205A-0860-049-10R1-P	103	63	40	61	10
8,7	49	03046207	SD205A-0870-049-10R1-P	103	63	40	61	10
8,731	49	03046341	SD205A-0873-049-10R1-P	103	63	40	61	10
8,8	49	03046208	SD205A-0880-049-10R1-P	103	63	40	61	10
8,9	49	03046209	SD205A-0890-049-10R1-P	103	63	40	61	10
9,0	49	03046210	SD205A-0900-049-10R1-P	103	63	40	61	10
9,1	49	03046211	SD205A-0910-049-10R1-P	103	63	40	61	10
9,128	49	03046342	SD205A-0913-049-10R1-P	103	63	40	61	10
9,2	49	03046212	SD205A-0920-049-10R1-P	103	63	40	61	10
9,3	49	03046213	SD205A-0930-049-10R1-P	103	63	40	61	10
9,4	49	03046214	SD205A-0940-049-10R1-P	103	63	40	61	10
9,5	49	03046215	SD205A-0950-049-10R1-P	103	63	40	61	10
9,525	49	03046343	SD205A-0953-049-10R1-P	103	63	40	61	10
9,55	49	03046216	SD205A-0955-049-10R1-P	103	63	40	61	10
9,6	49	03046217	SD205A-0960-049-10R1-P	103	63	40	61	10
9,7	49	03046218	SD205A-0970-049-10R1-P	103	63	40	61	10
9,8	49	03046219	SD205A-0980-049-10R1-P	103	63	40	61	10
9,9	49	03046220	SD205A-0990-049-10R1-P	103	63	40	61	10
9,922	49	03046344	SD205A-0992-049-10R1-P	103	63	40	61	10
10,0	49	03046221	SD205A-1000-049-10R1-P	103	63	40	61	10
10,1	56	03046222	SD205A-1010-056-12R1-P	118	73	45	71	12
10,2	56	03046223	SD205A-1020-056-12R1-P	118	73	45	71	12
10,3	56	03046224	SD205A-1030-056-12R1-P	118	73	45	71	12
10,319	56	03046345	SD205A-1032-056-12R1-P	118	73	45	71	12
10,4	56	03046225	SD205A-1040-056-12R1-P	118	73	45	71	12
10,5	56	03046226	SD205A-1050-056-12R1-P	118	73	45	71	12
10,6	56	03046227	SD205A-1060-056-12R1-P	118	73	45	71	12
10,7	56	03046228	SD205A-1070-056-12R1-P	118	73	45	71	12
10,716	56	03046346	SD205A-1072-056-12R1-P	118	73	45	71	12
10,8	56	03046229	SD205A-1080-056-12R1-P	118	73	45	71	12
10,9	56	03046230	SD205A-1090-056-12R1-P	118	73	45	71	12
11,0	56	03046231	SD205A-1100-056-12R1-P	118	73	45	71	12
11,1	56	03046232	SD205A-1110-056-12R1-P	118	73	45	71	12
11,113	56	03046347	SD205A-1111-056-12R1-P	118	73	45	71	12
11,2	56	03046233	SD205A-1120-056-12R1-P	118	73	45	71	12
11,3	56	03046234	SD205A-1130-056-12R1-P	118	73	45	71	12
11,4	56	03046235	SD205A-1140-056-12R1-P	118	73	45	71	12
11,5	56	03046236	SD205A-1150-056-12R1-P	118	73	45	71	12
11,509	56	03046348	SD205A-1151-056-12R1-P	118	73	45	71	12

For intermediate diameters see the MyDesign software.

Drilling depth ~ 5 x D – Metric

Cylindrical shank DIN 6537A

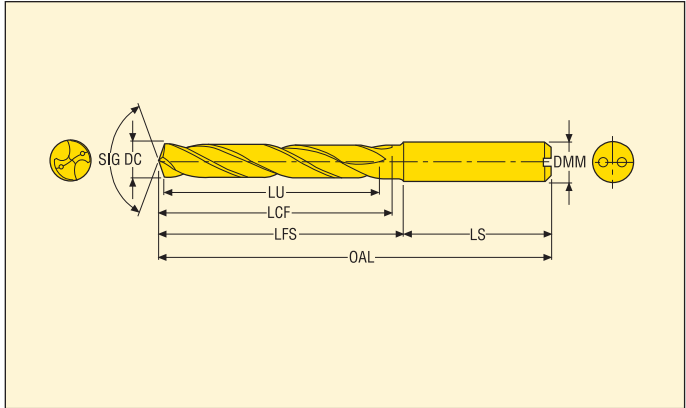

- Internal coolant
- Point angle: 140°
- Coating: TiAlN
- Hole tolerance: IT8-9
- For cutting data see page(s) 105

DC m7 (mm)	LU	Ordering and Product No.	Designation	Dimensions in mm				
				OAL	LFS	LS	LCF	DMM
11,55	56	03046237	SD205A-1155-056-12R1-P	118	73	45	71	12
11,6	56	03046238	SD205A-1160-056-12R1-P	118	73	45	71	12
11,7	56	03046239	SD205A-1170-056-12R1-P	118	73	45	71	12
11,8	56	03046240	SD205A-1180-056-12R1-P	118	73	45	71	12
11,9	56	03046241	SD205A-1190-056-12R1-P	118	73	45	71	12
11,906	56	03046349	SD205A-1191-056-12R1-P	118	73	45	71	12
12,0	56	03046242	SD205A-1200-056-12R1-P	118	73	45	71	12
12,1	60	03046243	SD205A-1210-060-14R1-P	124	79	45	77	14
12,2	60	03046244	SD205A-1220-060-14R1-P	124	79	45	77	14
12,25	60	03046245	SD205A-1225-060-14R1-P	124	79	45	77	14
12,3	60	03138157	SD205A-1230-060-14R1-P	124	79	45	77	14
12,4	60	03046246	SD205A-1240-060-14R1-P	124	79	45	77	14
12,5	60	03046247	SD205A-1250-060-14R1-P	124	79	45	77	14
12,6	60	03046248	SD205A-1260-060-14R1-P	124	79	45	77	14
12,7	60	03120497	SD205A-1270-060-14R1-P	124	79	45	77	14
12,75	60	03046249	SD205A-1275-060-14R1-P	124	79	45	77	14
12,8	60	03046250	SD205A-1280-060-14R1-P	124	79	45	77	14
12,9	60	03046251	SD205A-1290-060-14R1-P	124	79	45	77	14
13,0	60	03046252	SD205A-1300-060-14R1-P	124	79	45	77	14
13,1	60	03046253	SD205A-1310-060-14R1-P	124	79	45	77	14
13,2	60	03046254	SD205A-1320-060-14R1-P	124	79	45	77	14
13,3	60	03046255	SD205A-1330-060-14R1-P	124	79	45	77	14
13,4	60	03046256	SD205A-1340-060-14R1-P	124	79	45	77	14
13,494	60	03046350	SD205A-1349-060-14R1-P	124	79	45	77	14
13,5	60	03046257	SD205A-1350-060-14R1-P	124	79	45	77	14
13,55	60	03138158	SD205A-1355-060-14R1-P	124	79	45	77	14
13,6	60	03046258	SD205A-1360-060-14R1-P	124	79	45	77	14
13,7	60	03046259	SD205A-1370-060-14R1-P	124	79	45	77	14
13,8	60	03046260	SD205A-1380-060-14R1-P	124	79	45	77	14
13,891	60	03120498	SD205A-1389-060-14R1-P	124	79	45	77	14
13,9	60	03046261	SD205A-1390-060-14R1-P	124	79	45	77	14
14,0	60	03046262	SD205A-1400-060-14R1-P	124	79	45	77	14
14,1	63	03046263	SD205A-1410-063-16R1-P	133	85	48	83	16
14,2	63	03046264	SD205A-1420-063-16R1-P	133	85	48	83	16
14,25	63	03138159	SD205A-1425-063-16R1-P	133	85	48	83	16
14,288	63	03046351	SD205A-1429-063-16R1-P	133	85	48	83	16
14,3	63	03046265	SD205A-1430-063-16R1-P	133	85	48	83	16
14,4	63	03046266	SD205A-1440-063-16R1-P	133	85	48	83	16
14,5	63	03046267	SD205A-1450-063-16R1-P	133	85	48	83	16
14,6	63	03046268	SD205A-1460-063-16R1-P	133	85	48	83	16
14,7	63	03046269	SD205A-1470-063-16R1-P	133	85	48	83	16
14,75	63	03046270	SD205A-1475-063-16R1-P	133	85	48	83	16

For intermediate diameters see the MyDesign software.

Drilling depth ~ 5 x D – Metric

Cylindrical shank DIN 6537A



- Internal coolant
- Point angle: 140°
- Coating: TiAlN
- Hole tolerance: IT8-9
- For cutting data see page(s) 105

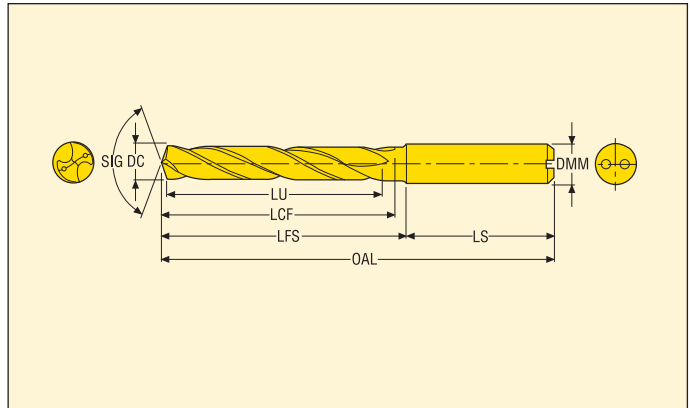

DC m7 (mm)	LU	Ordering and Product No.	Designation	Dimensions in mm				
				OAL	LFS	LS	LCF	DMM
14,8	63	03046271	SD205A-1480-063-16R1-P	133	85	48	83	16
14,9	63	03046272	SD205A-1490-063-16R1-P	133	85	48	83	16
15,0	63	03046273	SD205A-1500-063-16R1-P	133	85	48	83	16
15,1	63	03046274	SD205A-1510-063-16R1-P	133	85	48	83	16
15,2	63	03046275	SD205A-1520-063-16R1-P	133	85	48	83	16
15,25	63	03138160	SD205A-1525-063-16R1-P	133	85	48	83	16
15,3	63	03046276	SD205A-1530-063-16R1-P	133	85	48	83	16
15,4	63	03046277	SD205A-1540-063-16R1-P	133	85	48	83	16
15,5	63	03046278	SD205A-1550-063-16R1-P	133	85	48	83	16
15,6	63	03046280	SD205A-1560-063-16R1-P	133	85	48	83	16
15,7	63	03046281	SD205A-1570-063-16R1-P	133	85	48	83	16
15,8	63	03046282	SD205A-1580-063-16R1-P	133	85	48	83	16
15,875	63	03046352	SD205A-1588-063-16R1-P	133	85	48	83	16
15,9	63	03046283	SD205A-1590-063-16R1-P	133	85	48	83	16
16,0	63	03046284	SD205A-1600-063-16R1-P	133	85	48	83	16
16,1	71	03046285	SD205A-1610-071-18R1-P	143	95	48	93	18
16,2	71	03046286	SD205A-1620-071-18R1-P	143	95	48	93	18
16,25	71	03138161	SD205A-1625-071-18R1-P	143	95	48	93	18
16,3	71	03046287	SD205A-1630-071-18R1-P	143	95	48	93	18
16,4	71	03046288	SD205A-1640-071-18R1-P	143	95	48	93	18
16,5	71	03046289	SD205A-1650-071-18R1-P	143	95	48	93	18
16,6	71	03046290	SD205A-1660-071-18R1-P	143	95	48	93	18
16,669	71	03120499	SD205A-1667-071-18R1-P	143	95	48	93	18
16,7	71	03046291	SD205A-1670-071-18R1-P	143	95	48	93	18
16,75	71	03046292	SD205A-1675-071-18R1-P	143	95	48	93	18
16,8	71	03046293	SD205A-1680-071-18R1-P	143	95	48	93	18
16,9	71	03046294	SD205A-1690-071-18R1-P	143	95	48	93	18
17,0	71	03046296	SD205A-1700-071-18R1-P	143	95	48	93	18
17,1	71	03046297	SD205A-1710-071-18R1-P	143	95	48	93	18
17,2	71	03046298	SD205A-1720-071-18R1-P	143	95	48	93	18
17,3	71	03046299	SD205A-1730-071-18R1-P	143	95	48	93	18
17,4	71	03046300	SD205A-1740-071-18R1-P	143	95	48	93	18
17,463	71	03120500	SD205A-1746-071-18R1-P	143	95	48	93	18
17,5	71	03046301	SD205A-1750-071-18R1-P	143	95	48	93	18
17,6	71	03046302	SD205A-1760-071-18R1-P	143	95	48	93	18
17,7	71	03046303	SD205A-1770-071-18R1-P	143	95	48	93	18
17,8	71	03046304	SD205A-1780-071-18R1-P	143	95	48	93	18
17,9	71	03046305	SD205A-1790-071-18R1-P	143	95	48	93	18
18,0	71	03046306	SD205A-1800-071-18R1-P	143	95	48	93	18
18,1	77	03046307	SD205A-1810-077-20R1-P	153	103	50	101	20
18,2	77	03046308	SD205A-1820-077-20R1-P	153	103	50	101	20
18,3	77	03046309	SD205A-1830-077-20R1-P	153	103	50	101	20

For intermediate diameters see the MyDesign software.

Drilling depth ~ 6 x D

Cylindrical shank



- Internal coolant
- Point angle: 140°
- Coating: TiAlN
- Hole tolerance: IT9
- For cutting data see page(s) 107

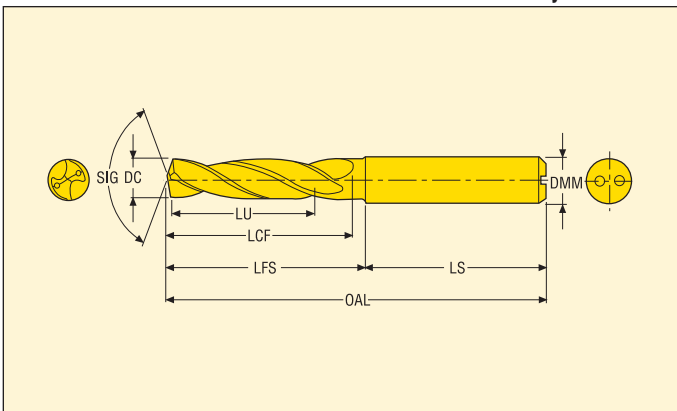

DC	LU	Ordering and Product No.	Designation	Dimensions in mm		
				OAL	LUX	DMM
1,0	6,0	02731658	SD206A-1.00-6.0-3R1	38	8,0	3
1,1	6,6	02731659	SD206A-1.10-6.6-3R1	38	8,6	3
1,2	7,2	02731660	SD206A-1.20-7.2-3R1	38	9,2	3
1,3	7,8	02731661	SD206A-1.30-7.8-3R1	38	9,8	3
1,4	8,4	02731662	SD206A-1.40-8.4-3R1	38	10,4	3
1,5	9,0	02731663	SD206A-1.50-9.0-3R1	38	11,0	3
1,6	9,6	02731664	SD206A-1.60-9.6-3R1	38	11,6	3
1,7	10,2	02731665	SD206A-1.70-10.2-3R1	38	12,2	3
1,8	10,8	02731666	SD206A-1.80-10.8-3R1	38	12,8	3
1,9	11,4	02731667	SD206A-1.90-11.4-3R1	38	13,4	3
2,0	12,0	02731668	SD206A-2.00-12.0-3R1	50	14,0	3

Drilling depth ~ 7 x D – Metric

Cylindrical shank DIN 6537A



- Internal coolant
- Point angle: 140°
- Coating: TiAlN
- Hole tolerance: IT9
- For cutting data see page(s) 106

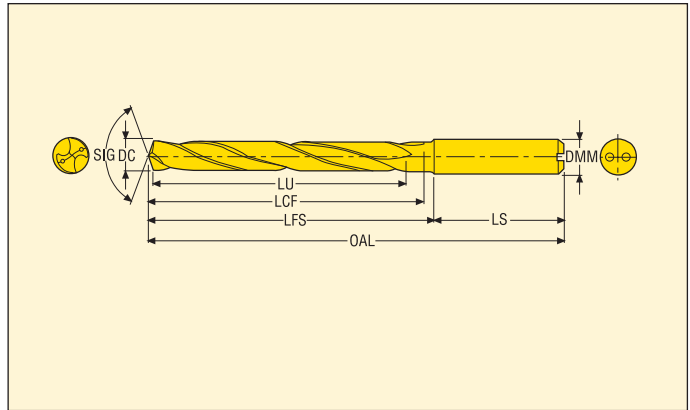

DC m7 (mm)	LU	Ordering and Product No.	Designation	Dimensions in mm				
				OAL	LFS	LS	LCF	DMM
3,0	30	03046358	SD207A-0300-030-06R1-P	74	38	36	36	6
3,3	30	03046359	SD207A-0330-030-06R1-P	74	38	36	36	6
3,5	30	03046360	SD207A-0350-030-06R1-P	74	38	36	36	6
4,0	37	03046361	SD207A-0400-037-06R1-P	82	46	36	43	6
4,5	37	03046412	SD207A-0450-037-06R1-P	82	46	36	43	6
4,8	45	03046413	SD207A-0480-045-06R1-P	94	58	36	56	6
5,0	45	03046414	SD207A-0500-045-06R1-P	94	58	36	56	6
5,2	45	03046362	SD207A-0520-045-06R1-P	94	58	36	56	6
5,5	45	03046363	SD207A-0550-045-06R1-P	94	58	36	56	6
5,8	45	03046407	SD207A-0580-045-06R1-P	94	58	36	56	6
6,0	45	03046364	SD207A-0600-045-06R1-P	94	58	36	56	6
6,35	57	03046365	SD207A-0635-057-08R1-P	110	74	36	67	8
6,5	57	03046366	SD207A-0650-057-08R1-P	110	74	36	67	8
6,8	57	03046367	SD207A-0680-057-08R1-P	110	74	36	67	8
6,9	57	03046368	SD207A-0690-057-08R1-P	110	74	36	67	8
7,0	57	03046369	SD207A-0700-057-08R1-P	110	74	36	67	8
7,5	57	03046370	SD207A-0750-057-08R1-P	110	74	36	72	8
7,8	57	03046371	SD207A-0780-057-08R1-P	110	74	36	72	8
8,0	57	03046372	SD207A-0800-057-08R1-P	110	74	36	72	8
8,5	62	03046373	SD207A-0850-062-10R1-P	122	82	40	80	10
8,6	62	03046374	SD207A-0860-062-10R1-P	122	82	40	80	10
8,7	62	03046411	SD207A-0870-062-10R1-P	122	82	40	80	10
8,8	62	03046408	SD207A-0880-062-10R1-P	122	82	40	80	10
9,0	62	03046375	SD207A-0900-062-10R1-P	122	82	40	80	10
9,5	62	03046376	SD207A-0950-062-10R1-P	122	82	40	80	10
9,525	62	03046377	SD207A-0953-062-10R1-P	122	82	40	80	10
9,75	62	03046402	SD207A-0975-062-10R1-P	122	82	40	80	10
9,8	62	03046403	SD207A-0980-062-10R1-P	122	82	40	80	10
10,0	62	03046378	SD207A-1000-062-10R1-P	122	82	40	80	10
10,2	72	03046379	SD207A-1020-072-12R1-P	141	96	45	94	12
10,4	72	03046401	SD207A-1040-072-12R1-P	141	96	45	94	12
10,5	72	03046380	SD207A-1050-072-12R1-P	141	96	45	94	12
10,8	72	03046404	SD207A-1080-072-12R1-P	141	96	45	94	12
11,0	72	03046381	SD207A-1100-072-12R1-P	141	96	45	94	12
11,5	72	03046382	SD207A-1150-072-12R1-P	141	96	45	94	12
11,8	72	03046405	SD207A-1180-072-12R1-P	141	96	45	94	12
12,0	72	03046383	SD207A-1200-072-12R1-P	141	96	45	94	12
12,25	83	03046415	SD207A-1225-083-14R1-P	155	110	45	108	14
12,5	83	03046384	SD207A-1250-083-14R1-P	155	110	45	108	14
12,7	83	03046385	SD207A-1270-083-14R1-P	155	110	45	108	14
12,8	83	03046416	SD207A-1280-083-14R1-P	155	110	45	108	14
13,0	83	03046386	SD207A-1300-083-14R1-P	155	110	45	108	14

For intermediate diameters see the MyDesign software.

Drilling depth ~ 16 x D

Cylindrical shank DIN 6537A

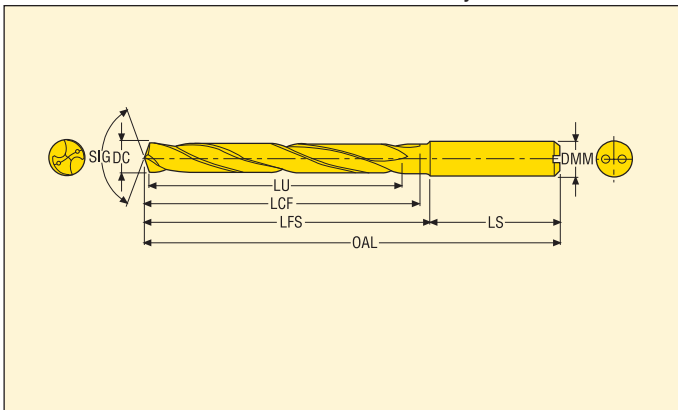

- Internal coolant
- Point angle: 136°
- Coating: TiAIN + TIN
- Hole tolerance: IT9
- For cutting data see page(s) 108

DC m7 (mm)	DC m7 (inch)	LU	Ordering and Product No.	Designation	Dimensions in mm				
					OAL	LFS	LS	LCF	DMM
3,0	–	50	02712383	SD216A-3.0-50-4R1	88	61	27	56	4
3,5	–	60	02712384	SD216A-3.5-60-4R1	99	72	27	67	4
4,0	–	60	02712385	SD216A-4.0-60-4R1	99	72	27	67	4
4,5	–	70	02712386	SD216A-4.5-70-6R1	117	81	36	79	6
5,0	–	90	02637529	SD216A-5.0-90-6R1	142	106	36	103	6
5,5	–	90	02637530	SD216A-5.5-90-6R1	142	106	36	103	6
6,0	–	90	02637531	SD216A-6.0-90-6R1	142	106	36	103	6
6,35	1/4	120	02656536	SD216A-6.35-120-8R1	177	141	36	137	8
6,5	–	120	02637532	SD216A-6.5-120-8R1	177	141	36	137	8
7,0	–	120	02637533	SD216A-7.0-120-8R1	177	141	36	137	8
7,5	–	120	02637534	SD216A-7.5-120-8R1	177	141	36	137	8
8,0	–	120	02637536	SD216A-8.0-120-8R1	177	141	36	137	8
8,5	–	150	02637539	SD216A-8.5-150-10R1	216	176	40	172	10
9,0	–	150	02637540	SD216A-9.0-150-10R1	216	176	40	172	10
9,5	–	150	02637541	SD216A-9.5-150-10R1	216	176	40	172	10
9,52	3/8	150	02656537	SD216A-9.52-150-10R1	216	176	40	172	10
10,0	–	150	02637542	SD216A-10.0-150-10R1	216	176	40	172	10
10,5	–	180	02637543	SD216A-10.5-180-12R1	256	211	45	207	12
11,0	–	180	02637544	SD216A-11.0-180-12R1	256	211	45	207	12
11,5	–	180	02637545	SD216A-11.5-180-12R1	256	211	45	207	12
12,0	–	180	02637546	SD216A-12.0-180-12R1	256	211	45	207	12

For intermediate diameters see Custom Design software.

Drilling depth ~ 5 x D

Cylindrical shank DIN 6537A



- Internal coolant
- Point angle: 140°/180°
- Coating: TiAIN + TiN
- Hole tolerance: IT8
- For cutting data see page(s) 109

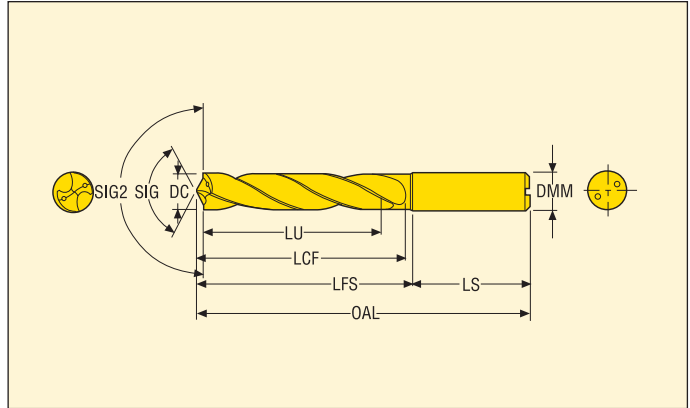

DC m7 (mm)	DC m7 (inch)	LU	Ordering and Product No.	Designation	Dimensions in mm				
					OAL	LFS	LS	LCF	DMM
5.0	—	32	02691683	SD245A-5.0-32-6R1	82	46	36	44	6
6.0	—	32	02691684	SD245A-6.0-32-6R1	82	46	36	44	6
6.35	1/4	35	02691686	SD245A-02500-138-0315R1	91	55	36	53	8
6.5	—	35	02691687	SD245A-6.5-35-8R1	91	55	36	53	8
6.747	17/64	40	02691688	SD245A-02656-157-0315R1	91	55	36	53	8
6.8	—	40	02691689	SD245A-6.8-40-8R1	91	55	36	53	8
7.0	—	40	02691690	SD245A-7.0-40-8R1	91	55	36	53	8
7.144	9/32	40	02691691	SD245A-02813-157-0315R1	91	55	36	53	8
7.5	—	40	02691692	SD245A-7.5-40-8R1	91	55	36	53	8
7.938	5/16	42	02691693	SD245A-03125-165-0315R1	91	55	36	53	8
8.0	—	42	02691694	SD245A-8.0-42-8R1	91	55	36	53	8
8.5	—	42	02691695	SD245A-8.5-42-10R1	103	63	40	61	10
9.0	—	45	02546059	SD245A-9.0-45-10R1	103	63	40	61	10
9.5	—	45	02691696	SD245A-9.5-45-10R1	103	63	40	61	10
9.525	3/8	48	02691697	SD245A-03750-189-0394R1	103	63	40	61	10
10.0	—	48	02536888	SD245A-10.0-48-10R1	103	63	40	61	10
10.2	—	48	02691699	SD245A-10.2-48-12R1	118	73	45	71	12
10.319	13/32	48	02691700	SD245A-04063-189-0472R1	118	73	45	71	12
10.5	—	48	02691701	SD245A-10.5-48-12R1	118	73	45	71	12
11.0	—	56	02561860	SD245A-11.0-56-12R1	118	73	45	71	12
11.113	7/16	56	02691702	SD245A-04375-221-0472R1	118	73	45	71	12
11.5	—	56	02691704	SD245A-11.5-56-12R1	118	73	45	71	12
12.0	—	56	02691705	SD245A-12.0-56-12R1	118	73	45	71	12
12.5	—	56	02691706	SD245A-12.5-56-14R1	124	79	45	77	14
12.7	1/2	56	02691707	SD245A-0500-221-0551R1	124	79	45	77	14
13.0	—	56	02691708	SD245A-13.0-56-14R1	124	79	45	77	14
13.494	17/32	59	02691709	SD245A-05312-232-0551R1	124	79	45	77	14
13.5	—	59	02691710	SD245A-13.5-59-14R1	124	79	45	77	14
14.0	—	59	02691711	SD245A-14.0-59-14R1	124	79	45	77	14

For intermediate diameters see Custom Design software.

Chamfer drills – M4 - M16 Thread

Cylindrical shank DIN 6537A



- Internal coolant
- Coating: TiAIN + TiN
- Hole tolerance: IT8-9
- For cutting data see page(s) 102-103

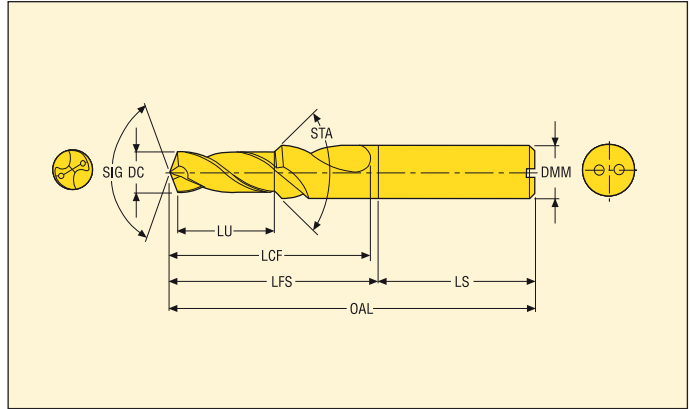

Tap thread type	DC	Tap thread type	LU	Ordering and Product No.	Designation	Dimensions in mm				
						OAL	LFS	LS	LCF	DMM
Normal pitch Metric thread	3,3	M4	11,4	02500320	SD203A-C45-3.3-11.4-6R1	66,0	26,0	36,0	20,0	6,0
	3,4	M4	11,4	02500323	SD203A-C45-3.4-11.4-6R1	66,0	26,0	36,0	20,0	6,0
	4,2	M5	13,6	02500324	SD203A-C45-4.2-13.6-6R1	66,0	30,0	36,0	24,0	6,0
	4,3	M5	13,6	02500325	SD203A-C45-4.3-13.6-6R1	66,0	30,0	36,0	24,0	6,0
	5,0	M6	16,5	02500326	SD203A-C45-5.0-16.5-8R1	79,0	43,0	36,0	28,0	8,0
	5,1	M6	16,5	02500327	SD203A-C45-5.1-16.5-8R1	79,0	43,0	36,0	28,0	8,0
	6,8	M8	21,0	02500328	SD203A-C45-6.8-21-10R1	89,0	49,0	40,0	34,0	10,0
	6,9	M8	21,0	02500330	SD203A-C45-6.9-21-10R1	89,0	49,0	40,0	34,0	10,0
	8,5	M10	25,5	02500333	SD203A-C45-8.5-25.5-12R1	102,0	57,0	45,0	47,0	12,0
	8,7	M10	25,5	02500334	SD203A-C45-8.7-25.5-12R1	102,0	57,0	45,0	47,0	12,0
	10,2	M12	30,0	02500342	SD203A-C45-10.2-30.0-14R1	107,0	62,0	45,0	55,0	14,0
	10,4	M12	30,0	02500343	SD203A-C45-10.4-30.0-14R1	107,0	62,0	45,0	55,0	14,0
	12,0	M14	34,5	02500346	SD203A-C45-12.0-34.5-16R1	115,0	70,0	45,0	60,0	16,0
	12,25	M14	34,5	02500348	SD203A-C45-12.25-34.5-16R1	115,0	70,0	45,0	60,0	16,0
14,0	M16	38,5	02500350	SD203A-C45-14.0-38.5-18R1	123,0	75,0	48,0	65,0	18,0	
14,25	M16	38,5	02500354	SD203A-C45-14.25-38.5-18R1	123,0	75,0	48,0	65,0	18,0	
Fine pitch Metric thread	7,0	M8x1.0	21,0	02500331	SD203A-C45-7.0-21-10R1	89,0	49,0	40,0	34,0	10,0
	9,0	M10x1.0	25,5	02500340	SD203A-C45-9.0-25.5-12R1	102,0	57,0	45,0	47,0	12,0
	10,5	M12x1.5	34,5	02500344	SD203A-C45-10.5-30.0-14R1	107,0	62,0	45,0	55,0	14,0
	12,5	M14x1.5	34,5	02500349	SD203A-C45-12.5-34.5-16R1	115,0	70,0	45,0	60,0	16,0
	14,5	M16x1.5	38,5	02500356	SD203A-C45-14.5-38.5-18R1	123,0	75,0	48,0	65,0	18,0

Chamfer drills – M4 - M16 Thread

Whistle Notch shank DIN6537B

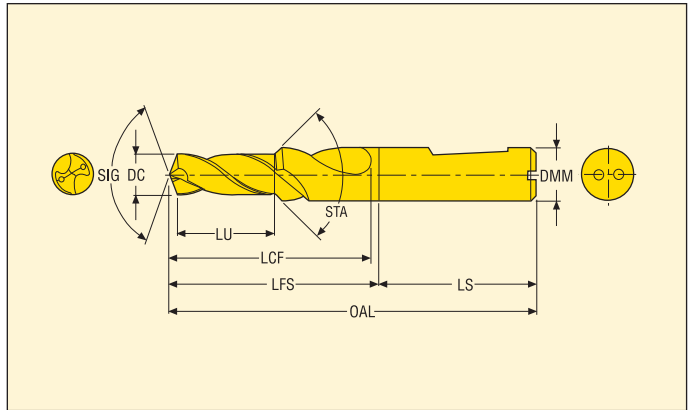

- Internal coolant
- Coating: TiAlN + TiN
- Hole tolerance: IT8-9
- For cutting data see page(s) 102-103

Tap thread type	DC	Tap thread type	LU	Ordering and Product No.	Designation	Dimensions in mm				
						OAL	LFS	LS	LCF	DMM
Normal pitch Metric thread	3,3	M4	11,4	02500382	SD203A-C45-3.3-11.4-6R5	66,0	26,0	36,0	20,0	6,0
	3,4	M4	11,4	02500383	SD203A-C45-3.4-11.4-6R5	66,0	26,0	36,0	20,0	6,0
	4,2	M5	13,6	02500391	SD203A-C45-4.2-13.6-6R5	66,0	30,0	36,0	24,0	6,0
	4,3	M5	13,6	02500392	SD203A-C45-4.3-13.6-6R5	66,0	30,0	36,0	24,0	6,0
	5,0	M6	16,5	02500393	SD203A-C45-5.0-16.5-8R5	79,0	43,0	36,0	28,0	8,0
	5,1	M6	16,5	02500394	SD203A-C45-5.1-16.5-8R5	79,0	43,0	36,0	28,0	8,0
	6,8	M8	21,0	02500395	SD203A-C45-6.8-21.0-10R5	89,0	49,0	40,0	34,0	10,0
	6,9	M8	21,0	02500396	SD203A-C45-6.9-21.0-10R5	89,0	49,0	40,0	34,0	10,0
	8,5	M10	25,5	02500401	SD203A-C45-8.5-25.5-12R5	102,0	57,0	45,0	47,0	12,0
	8,7	M10	25,5	02500403	SD203A-C45-8.7-25.5-12R5	102,0	57,0	45,0	47,0	12,0
	10,2	M12	30,0	02500412	SD203A-C45-10.2-30.0-14R5	107,0	62,0	45,0	55,0	14,0
	10,4	M12	30,0	02500414	SD203A-C45-10.4-30.0-14R5	107,0	62,0	45,0	55,0	14,0
	12,0	M14	34,5	02500417	SD203A-C45-12.0-34.5-16R5	115,0	70,0	45,0	60,0	16,0
	12,25	M14	34,5	02500418	SD203A-C45-12.25-34.5-16R5	115,0	70,0	45,0	60,0	16,0
	14,0	M16	38,5	02500423	SD203A-C45-14.0-38.5-18R5	123,0	75,0	48,0	65,0	18,0
14,25	M16	38,5	02500424	SD203A-C45-14.25-38.5-18R5	123,0	75,0	48,0	65,0	18,0	
Fine pitch Metric thread	7,0	M8x1.0	21,0	02500398	SD203A-C45-7.0-21.0-10R5	89,0	49,0	40,0	34,0	10,0
	9,0	M10x1.0	25,5	02500410	SD203A-C45-9.0-25.5-12R5	102,0	57,0	45,0	47,0	12,0
	10,5	M12x1.5	34,5	02500416	SD203A-C45-10.5-30.0-14R5	107,0	62,0	45,0	55,0	14,0
	12,5	M14x1.5	34,5	02500420	SD203A-C45-12.5-34.5-16R5	115,0	70,0	45,0	60,0	16,0
	14,5	M16x1.5	38,5	02500425	SD203A-C45-14.5-38.5-18R5	123,0	75,0	48,0	65,0	18,0

Chamfer module

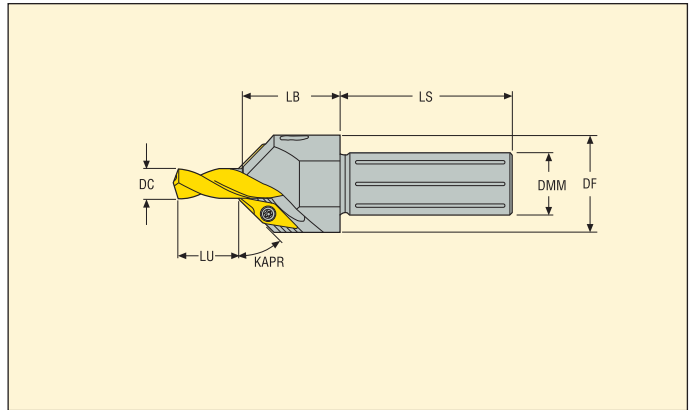

Ordering and Product No.	Designation	DC	Drill depth LU					Dimensions in mm			
			SD203 LU (min-max)	SD203A LU (min-max)	SD205A LU (min-max)	SD207A LU (min-max)	Max chamfer depth	LB	DF	LS	DMM
02510275	SD200-C45-6R1	4,01-6,1	4,0-17,0	4,0-17,0	10,0-27,0	30,0-45,0	2,8	25	21	41	12
02510278	SD200-C45-8R1	6,01-8,0	15,0-27,0	15,0-27,0	24,0-35,0	42,0-57,0	2,8	25	25	45	16
02510280	SD200-C45-10R1	8,01-10,0	17,0-31,0	17,0-31,0	34,0-48,0	47,0-62,0	2,8	25	25	45	16
02510281	SD200-C45-12R1	10,01-12,0	21,0-36,0	21,0-36,0	40,0-56,0	57,0-72,0	2,8	25	28	47	20
02510283	SD200-C45-14R1	12,01-14,0	22,0-37,0	22,0-37,0	43,0-59,0	68,0-83,0	2,8	25	30	47	20
02510285	SD200-C45-16R1	14,01-16,0	23,0-39,0	23,0-39,0	44,0-60,0	76,0-92,0	2,8	34	32	53	25

Spare Parts, included in delivery

For drill dia (mm)	Insert key	Insert screw	Locking key	Locking screw	Cassette
	Insert	Insert	Module	Module	Module
4,00 - 16,00	T07P-2	C02205-T07P	H1.5-2D	SH3040	SD200-3x7.3

Insert

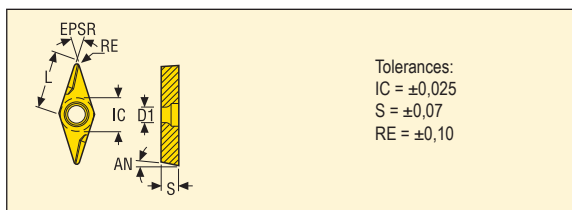

Size	Dimensions in mm				
	IC	L	S	D1	RE
C45	5,556	9,000	2,500	2,900	0,200
Designation	T400D				
SD200-C45					

Chamfer module mounting instructions

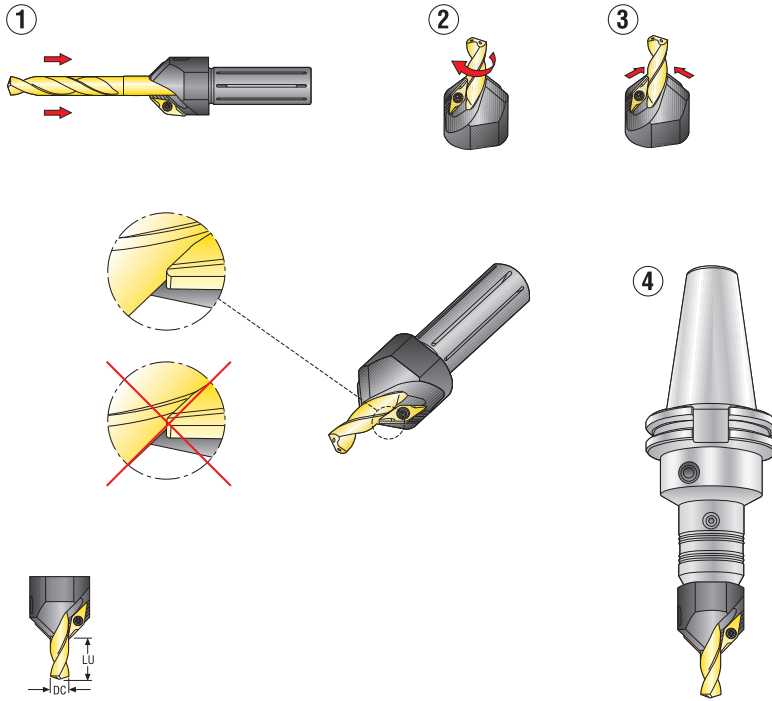

DC		LU drilling depth (min-max)									
		SD203		SD203A		SD205A		SD207A			
(mm)	(inch)	(mm)	(inch)	(mm)	(inch)	(mm)	(inch)	(mm)	(inch)		
4,00-4,75	.157-.187	4-17	.157-.669	4-17	.157-.669	10-27	.394-1.063	30-45	1.181-1.772		
4,76-6,00	.187-.236	6-20	.236-.787	6-20	.236-.787	18-32	.709-1.260	30-45	1.181-1.772		
6,01-8,00	.241-.315	15-27	.590-1.063	15-27	.590-1.063	28-42	1.102-1.653	42-57	1.653-2.244		
8,01-10,00	.315-.394	17-31	.669-1.220	17-31	.669-1.220	34-48	1.338-1.890	47-62	1.850-2.441		
10,01-12,00	.394-.472	21-36	.826-1.417	21-36	.826-1.417	40-56	1.575-2.205	57-72	2.244-2.835		
12,01-14,00	.473-.551	22-37	.866-1.457	22-37	.866-1.457	43-59	1.693-2.323	68-83	2.677-3.268		
14,01-16,00	.552-.630	23-39	.906-1.535	23-39	.906-1.535	44-60	1.732-2.362	76-92	2.992-3.622		

To be used with cylindrical shank only (R1).

Maximum chamfer depth

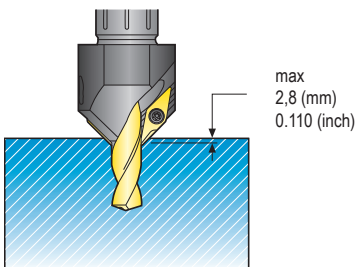

For difficult machining materials



Drilling depth ~ 3 x D

Cylindrical shank DIN 6537A

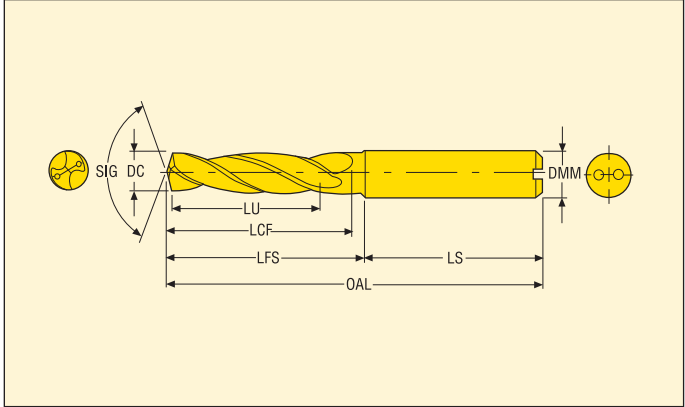

- Internal coolant
- Point angle: 140°
- Coating: TiAlN + TiN
- Hole tolerance: IT8-9
- For cutting data see page(s) 102-103

DC m7 (mm)	DC m7 (inch)	LU	Ordering and Product No.	Designation	Dimensions in mm				
					OAL	LFS	LS	LCF	DMM
3.0	–	14	02569995	SD203A-3.0-14-6R1-M	62	26	36	20	6
3.1	–	14	02570998	SD203A-3.1-14-6R1-M	62	26	36	20	6
3.3	–	14	02555958	SD203A-3.3-14-6R1-M	62	26	36	20	6
3.4	–	14	02570984	SD203A-3.4-14-6R1-M	62	26	36	20	6
3.5	–	15	02533784	SD203A-3.5-15-6R1-M	62	26	36	20	6
3.9	–	17	02570988	SD203A-3.9-17-6R1-M	66	30	36	24	6
4.0	–	17	02539902	SD203A-4.0-17-6R1-M	66	30	36	24	6
4.2	–	17	02555959	SD203A-4.2-17-6R1-M	66	30	36	24	6
4.3	–	18	02533700	SD203A-4.3-18-6R1-M	66	30	36	24	6
4.5	–	18	02570993	SD203A-4.5-18-6R1-M	66	30	36	24	6
4.763	3/16	20	02450103	SD203A-01875-079-0236R1-M	66	30	36	28	6
4.8	–	20	02570982	SD203A-4.8-20-6R1-M	66	30	36	28	6
4.9	–	20	02592709	SD203A-4.9-20-6R1-M	66	30	36	28	6
5.0	–	20	02450075	SD203A-5.0-20-6R1-M	66	30	36	28	6
5.5	–	20	02544249	SD203A-5.5-21-6R1-M	66	30	36	28	6
5.558	7/32	20	02450104	SD203A-02188-083-0236R1-M	66	30	36	28	6
5.6	–	21	02544028	SD203A-5.6-21-6R1-M	66	30	36	28	6
5.9	–	21	02515290	SD203A-5.9-21-6R1-M	66	30	36	28	6
6.0	–	21	02450076	SD203A-6.0-21-6R1-M	66	30	36	28	6
6.35	1/4	23	02450105	SD203A-02500-091-0315R1-M	79	43	36	34	8
6.5	–	23	02450077	SD203A-6.5-23-8R1-M	79	43	36	34	8
6.6	–	23	02450078	SD203A-6.6-23-8R1-M	79	43	36	34	8
6.746	17/64	25	02450106	SD203A-02656-098-0315R1-M	79	43	36	34	8
6.8	–	25	02450079	SD203A-6.8-25-8R1-M	79	43	36	34	8
6.9	–	25	02450080	SD203A-6.9-25-8R1-M	79	43	36	34	8
7.0	–	25	02450081	SD203A-7.0-25-8R1-M	79	43	36	34	8
7.145	9/32	25	02450107	SD203A-02813-098-0315R1-M	79	43	36	41	8
7.2	–	25	02537185	SD203A-7.2-25-8R1-M	79	43	36	41	8
7.3	–	25	02530109	SD203A-7.3-25-8R1-M	79	43	36	41	8
7.5	–	25	02450082	SD203A-7.5-25-8R1-M	79	43	36	41	8
7.6	–	27	02545197	SD203A-7.6-27-8R1-M	79	43	36	41	8
7.8	–	27	02450083	SD203A-7.8-27-8R1-M	79	43	36	41	8
7.938	5/16	27	02450108	SD203A-03125-106-0315R1-M	79	43	36	41	8
8.0	–	27	02450084	SD203A-8.0-27-8R1-M	79	43	36	41	8
8.5	–	27	02450085	SD203A-8.5-27-10R1-M	89	49	40	47	10
8.733	11/32	29	02450109	SD203A-03438-114-0394R1-M	89	49	40	47	10
8.8	–	29	02450086	SD203A-8.8-29-10R1-M	89	49	40	47	10
9.0	–	29	02450087	SD203A-9.0-29-10R1-M	89	49	40	47	10
9.129	23/64	29	02450110	SD203A-03594-114-0394R1-M	89	49	40	47	10
9.2	–	29	02546516	SD203A-9.2-29-10R1-M	89	49	40	47	10
9.3	–	29	02582375	SD203A-9.3-29-10R1-M	89	49	40	47	10
9.5	–	29	02450088	SD203A-9.5-29-10R1-M	89	49	40	47	10

For intermediate diameters see Custom Design software.

Drilling depth ~ 3 x D

Cylindrical shank DIN 6537A



- Internal coolant
- Point angle: 140°
- Coating: TiAlN + TiN
- Hole tolerance: IT8-9
- For cutting data see page(s) 103

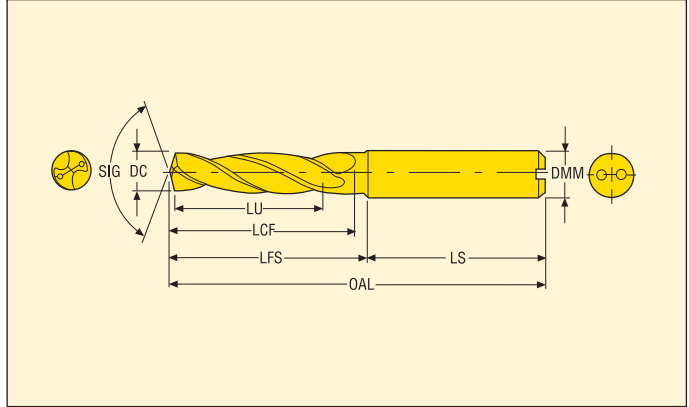

DC m7 (mm)	DC m7 (inch)	LU	Ordering and Product No.	Designation	Dimensions in mm				
					OAL	LFS	LS	LCF	DMM
9,525	3/8	29	02450111	SD203A-03750-122-0394R1-M	89	49	40	47	10
9,8	-	31	02450089	SD203A-9.8-31-10R1-M	89	49	40	47	10
9,9	-	31	02515293	SD203A-9.9-31-10R1-M	89	49	40	47	10
10,0	-	31	02450090	SD203A-10.0-31-10R1-M	89	49	40	47	10
10,2	-	31	02450091	SD203A-10.2-31-12R1-M	102	57	45	55	12
10,32	13/32	31	02450112	SD203A-04063-122-0472R1-M	102	57	45	55	12
10,4	-	31	02535267	SD203A-10.4-31-12R1-M	102	57	45	55	12
10,5	-	31	02450092	SD203A-10.5-31-12R1-M	102	57	45	55	12
10,716	27/64	33	02450113	SD203A-04219-130-0472R1-M	102	57	45	55	12
10,8	-	33	02450093	SD203A-10.8-33-12R1-M	102	57	45	55	12
11,0	-	33	02450094	SD203A-11.0-33-12R1-M	102	57	45	55	12
11,113	7/16	33	02450114	SD203A-04375-130-0472R1-M	102	57	45	55	12
11,5	-	33	02450095	SD203A-11.5-33-12R1-M	102	57	45	55	12
11,8	-	33	02450096	SD203A-11.8-33-12R1-M	102	57	45	55	12
11,908	15/32	36	02592711	SD203A-04688-142-0472R1-M	102	57	45	55	12
12,0	-	36	02450097	SD203A-12.0-36-12R1-M	102	57	45	55	12
12,25	-	36	02592712	SD203A-12.25-36-14R1-M	107	62	45	60	14
12,3	-	36	02450098	SD203A-12.3-36-14R1-M	107	62	45	60	14
12,5	-	36	02450099	SD203A-12.5-36-14R1-M	107	62	45	60	14
12,7	1/2	36	02450115	SD203A-05000-142-0551R1-M	107	62	45	60	14
12,9	-	36	02538263	SD203A-12.9-36-14R1-M	107	62	45	60	14
13,0	-	36	02450100	SD203A-13.0-36-14R1-M	107	62	45	60	14
13,5	-	37	02450101	SD203A-13.5-37-14R1-M	107	62	45	60	14
14,0	-	37	02450102	SD203A-14.0-37-14R1-M	107	62	45	60	14
14,25	-	38	02592715	SD203A-14.25-38-16R1-M	115	67	48	65	16

For intermediate diameters see Custom Design software.

Drilling depth ~ 5 x D

Cylindrical shank DIN 6537A

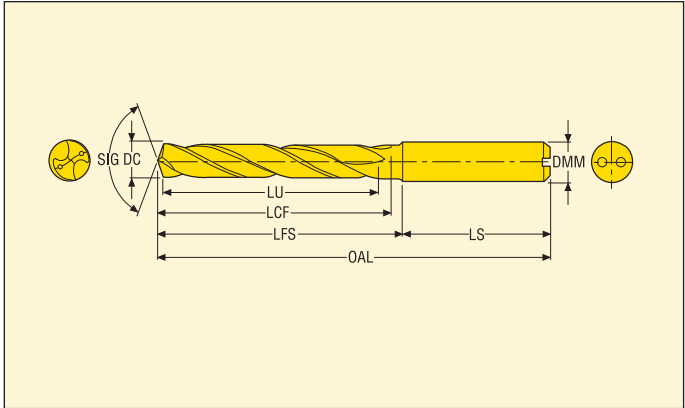

- Internal coolant
- Point angle: 140°
- Coating: TiAlN + TiN
- Hole tolerance: IT8-9
- For cutting data see page(s) 104-105

DC m7 (mm)	DC m7 (inch)	LU	Ordering and Product No.	Designation	Dimensions in mm				
					OAL	LFS	LS	LCF	DMM
2.5	–	13	02666989	SD205A-2.5-13-4R1-M	46	19	27	18	4
3.0	–	21	02556426	SD205A-3.0-21-6R1-M	66	30	36	26	6
3.1	–	21	02642448	SD205A-3.1-21-6R1-M	66	30	36	26	6
3.18	–	21	02541863	SD205A-3.18-21-6R1-M	66	30	36	26	6
3.3	–	21	02555960	SD205A-3.3-21-6R1-M	66	30	36	26	6
3.4	–	21	02554264	SD205A-3.4-21-6R1-M	66	30	36	26	6
3.5	–	21	02533780	SD205A-3.5-21-6R1-M	66	30	36	26	6
4.0	–	27	02508340	SD205A-4.0-27-6R1-M	74	38	36	34	6
4.2	–	27	02502549	SD205A-4.2-27-6R1-M	74	40	36	34	6
4.3	–	27	02592718	SD205A-4.3-27-6R1-M	74	38	36	34	6
4.5	–	27	02563659	SD205A-4.5-27-6R1-M	74	38	36	34	6
4.7	–	27	02604031	SD205A-4.7-27-6R1-M	74	40	36	34	6
4.763	3/16	32	02450062	SD205A-01875-126-0236R1-M	82	46	36	44	6
4.9	–	32	02592720	SD205A-4.9-32-6R1-M	82	46	36	44	6
5.0	–	32	02450034	SD205A-5.0-32-6R1-M	82	46	36	44	6
5.1	–	32	02600034	SD205A-5.1-32-6R1-M	82	46	36	44	6
5.2	–	32	02504408	SD205A-5.2-32-6R1-M	82	46	36	44	6
5.5	–	32	02537341	SD205A-5.5-32-6R1-M	82	46	36	44	6
5.558	7/32	32	02450063	SD205A-02188-126-0236R1-M	82	46	36	44	6
5.6	–	32	02612445	SD205A-5.6-32-6R1-M	82	46	36	44	6
5.9	–	32	02539334	SD205A-5.9-32-6R1-M	82	46	36	44	6
6.0	–	32	02450035	SD205A-6.0-32-6R1-M	82	46	36	44	6
6.2	–	35	02547543	SD205A-6.2-35-8R1-M	91	55	36	53	8
6.35	1/4	35	02450064	SD205A-02500-138-0315R1-M	91	55	36	53	8
6.4	–	35	02666488	SD205A-6.4-35-8R1-M	91	55	36	53	8
6.5	–	35	02450036	SD205A-6.5-35-8R1-M	91	55	36	53	8
6.6	–	35	02450037	SD205A-6.6-35-8R1-M	91	55	36	53	8
6.8	–	40	02450038	SD205A-6.8-40-8R1-M	91	55	36	53	8
6.9	–	40	02450039	SD205A-6.9-40-8R1-M	91	55	36	53	8
7.0	–	40	02450040	SD205A-7.0-40-8R1-M	91	55	36	53	8
7.145	9/32	40	02450066	SD205A-02813-157-0315R1-M	91	55	36	53	8
7.2	–	40	02519059	SD205A-7.2-40-8R1-M	91	55	36	53	8
7.5	–	40	02450041	SD205A-7.5-40-8R1-M	91	55	36	53	8
7.8	–	42	02450042	SD205A-7.8-42-8R1-M	91	55	36	53	8
7.938	5/16	42	02450067	SD205A-03125-165-0315R1-M	91	55	36	53	8
8.0	–	42	02450043	SD205A-8.0-42-8R1-M	91	55	36	53	8
8.1	–	42	02672327	SD205A-8.1-42-10R1-M	103	63	40	61	10
8.4	–	42	02570977	SD205A-8.4-42-10R1-M	103	63	40	61	10
8.5	–	42	02450044	SD205A-8.5-42-10R1-M	103	63	40	61	10
8.8	–	45	02450045	SD205A-8.8-45-10R1-M	103	63	40	61	10
9.0	–	45	02450046	SD205A-9.0-45-10R1-M	103	63	40	61	10
9.2	–	45	02516406	SD205A-9.2-45-10R1-M	103	42	40	61	10
9.5	–	45	02450047	SD205A-9.5-45-10R1-M	103	63	40	61	10

For intermediate diameters see Custom Design software.

Drilling depth ~ 5 x D

Cylindrical shank DIN 6537A

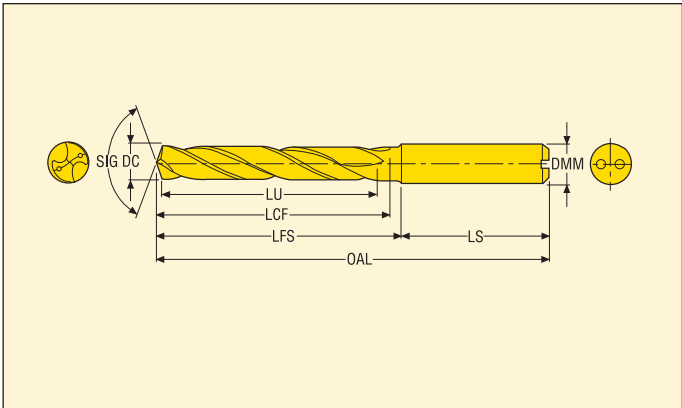

- Internal coolant
- Point angle: 140°
- Coating: TiAIN + TiN
- Hole tolerance: IT8-9
- For cutting data see page(s) 105

DC m7 (mm)	DC m7 (inch)	LU	Ordering and Product No.	Designation	Dimensions in mm				
					OAL	LFS	LS	LCF	DMM
9.525	3/8	48	02450070	SD205A-03750-189-0394R1-M	103	63	40	61	10
9.8	-	48	02450048	SD205A-9.8-48-10R1-M	103	63	40	61	10
10.0	-	48	02450049	SD205A-10.0-48-10R1-M	103	63	40	61	10
10.2	-	48	02450050	SD205A-10.2-48-12R1-M	118	73	45	71	12
10.5	-	48	02450051	SD205A-10.5-48-12R1-M	118	73	45	71	12
10.8	-	56	02450052	SD205A-10.8-56-12R1-M	118	73	45	71	12
10.9	-	56	02592725	SD205A-10.9-56-12R1-M	118	73	45	71	12
11.0	-	56	02450053	SD205A-11.0-56-12R1-M	118	73	45	71	12
11.113	7/16	56	02450073	SD205A-04375-221-0472R1-M	118	73	45	71	12
11.5	-	56	02450054	SD205A-11.5-56-12R1-M	118	73	45	71	12
11.8	-	56	02450055	SD205A-11.8-56-12R1-M	118	73	45	71	12
12.0	-	56	02450056	SD205A-12.0-56-12R1-M	118	73	45	71	12
12.5	-	56	02450058	SD205A-12.5-56-14R1-M	124	79	45	77	14
12.7	1/2	56	02450074	SD205A-05000-221-0551R1-M	124	79	45	77	14
12.9	-	56	02592729	SD205A-12.9-56-14R1-M	124	79	45	77	14
13.0	-	56	02450059	SD205A-13.0-56-14R1-M	124	79	45	77	14
13.5	-	59	02450060	SD205A-13.5-59-14R1-M	124	79	45	77	14
14.0	-	59	02450061	SD205A-14.0-59-14R1-M	124	79	45	77	14
14.25	-	60	02592732	SD205A-14.25-60-16R1-M	133	85	48	83	16
14.5	-	60	03117534	SD205A-14.5-60-16R1-M	133	85	48	83	16
15.0	-	60	02570652	SD205A-15.0-60-16R1-M	133	85	48	83	16
15.5	-	62	02543076	SD205A-15.5-62-16R1-M	133	85	48	83	16
16.0	-	62	02555961	SD205A-16.0-62-16R1-M	133	85	48	83	16

For intermediate diameters see Custom Design software.

Drilling depth ~ 3 x D

Cylindrical shank DIN 6537A



- Internal coolant
- Point angle: 140°
- Uncoated
- Hole tolerance: IT8-9
- Cutting data - www.secotools.com

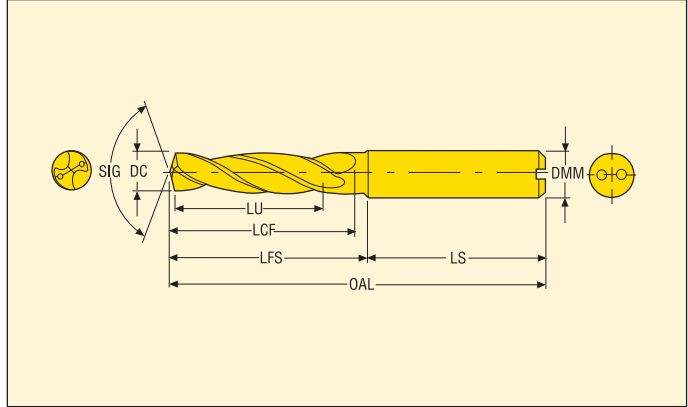

DC m7 (mm)	DC m7 (inch)	LU	Ordering and Product No.	Designation	Dimensions in mm				
					OAL	LFS	LS	LCF	DMM
4,763	3/16	20	02569147	SD203A-01875-079-0236R1-T	66	30	36	28	6
5,0	-	20	02523021	SD203A-5.0-20-6R1-T	66	30	36	28	6
5,558	7/32	20	02569156	SD203A-02188-083-0236R1-T	66	30	36	28	6
6,0	-	21	02542682	SD203A-6.0-21-6R1-T	66	30	36	28	6
6,35	1/4	23	02569149	SD203A-02500-091-0315R1-T	79	43	36	34	8
6,5	-	23	02545316	SD203A-6.5-23-8R1-T	79	43	36	34	8
6,9	-	25	02537280	SD203A-6.9-25-8R1-T	79	43	36	34	8
7,0	-	25	02525985	SD203A-7.0-25-8R1-T	79	43	36	34	8
7,145	9/32	25	02569151	SD203A-02813-098-0315R1-T	79	43	36	41	8
7,5	-	25	02527667	SD203A-7.5-25-8R1-T	79	43	36	41	8
7,938	5/16	27	02569152	SD203A-03125-106-0315R1-T	79	43	36	41	8
8,0	-	27	02513679	SD203A-8.0-27-8R1-T	79	43	36	41	8
8,5	-	27	02548250	SD203A-8.5-27-10R1-T	89	49	40	47	10
8,8	-	29	02569153	SD203A-8.8-29-10R1-T	89	49	40	47	10
9,0	-	29	02524440	SD203A-9.0-29-10R1-T	89	49	40	47	10
9,5	-	29	02545386	SD203A-9.5-29-10R1-T	89	49	40	47	10
10,0	-	31	02525984	SD203A-10.0-31-10R1-T	89	49	40	47	10
10,5	-	31	02545387	SD203A-10.5-31-12R1-T	102	57	45	55	12
11,0	-	33	02569155	SD203A-11.0-33-12R1-T	102	57	45	55	12
11,5	-	33	02567385	SD203A-11.5-33-12R1-T	102	57	45	55	12
12,0	-	36	02562784	SD203A-12.0-36-12R1-T	102	57	45	55	12

For intermediate diameters see Custom Design software.

Drilling depth ~ 5 x D

Cylindrical shank DIN 6537A



- Internal coolant
- Point angle: 140°
- Uncoated
- Hole tolerance: IT8-9
- Cutting data - www.secotools.com

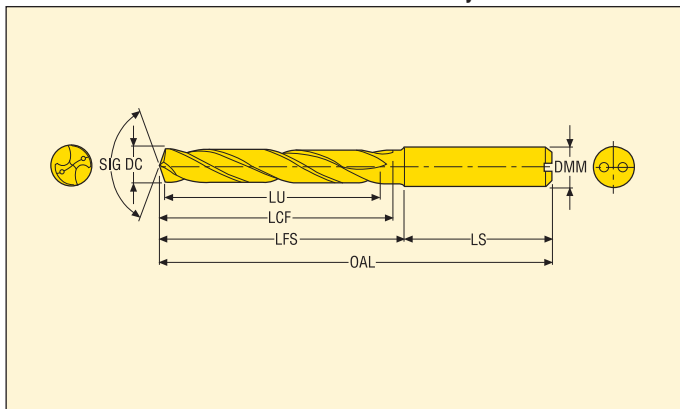

DC m7 (mm)	DC m7 (inch)	LU	Ordering and Product No.	Designation	Dimensions in mm					
					OAL	LFS	LS	LCF	DMM	
8,0	–	42	02569164	SD205A-8.0-42-8R1-T	91	55	36	53	8	
12,0	–	56	02527621	SD205A-12.0-56-12R1-T	118	73	45	71	12	

For intermediate diameters see Custom Design software.

Drilling depth ~ 3 x D

Cylindrical shank DIN 6537A

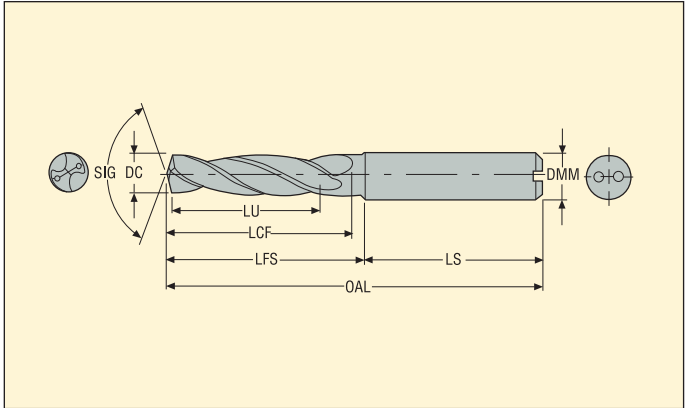

- Internal coolant
- Point angle: 140°
- DLC Coated
- Hole tolerance: IT8-9
- For cutting data see page(s) 102-103

DC m7 (mm)	DC m7 (inch)	LU	Ordering and Product No.	Designation	Dimensions in mm				
					OAL	LFS	LS	LCF	DMM
2.5	–	8	02691548	SD203A-2.5-8-4R1-N	44	16	28	13	4
3.0	–	14	02691549	SD203A-3.0-14-6R1-N	62	26	36	20	6
3.3	–	14	02691551	SD203A-3.3-14-6R1-N	62	26	36	20	6
3.5	–	15	02691552	SD203A-3.5-15-6R1-N	62	26	36	20	6
4.0	–	17	02691553	SD203A-4.0-17-6R1-N	66	30	36	24	6
4.1	–	17	02691554	SD203A-4.1-17-6R1-N	66	30	36	24	6
4.5	–	18	02691555	SD203A-4.5-18-6R1-N	66	30	36	24	6
5.0	–	20	02691556	SD203A-5.0-20-6R1-N	66	30	36	28	6
5.2	–	20	02691557	SD203A-5.2-20-6R1-N	66	30	36	28	6
5.5	–	20	02691558	SD203A-5.5-20-6R1-N	66	30	36	28	6
6.0	–	21	02691559	SD203A-6.0-21-6R1-N	66	30	36	28	6
6.35	1/4	23	02691560	SD203A-02500-091-0315R1-N	79	43	36	34	8
6.5	–	23	02691562	SD203A-6.5-23-8R1-N	79	43	36	34	8
6.746	17/64	25	02691564	SD203A-02656-098-0315R1-N	79	43	36	34	8
6.8	–	25	02691565	SD203A-6.8-25-8R1-N	79	43	36	34	8
7.0	–	25	02643590	SD203A-7.0-25-8R1-N	79	43	36	34	8
7.1	–	25	02691567	SD203A-7.1-25-8R1-N	79	43	36	34	8
7.145	9/32	25	02691568	SD203A-02813-098-0315R1-N	79	43	36	41	8
7.5	–	25	02691569	SD203A-7.5-25-8R1-N	79	43	36	41	8
7.938	5/16	27	02691570	SD203A-03125-106-0315R1-N	79	43	36	41	8
8.0	–	27	02691571	SD203A-8.0-27-8R1-N	79	43	36	41	8
8.5	–	27	02643592	SD203A-8.5-27-10R1-N	89	49	40	47	10
9.0	–	29	02691574	SD203A-9.0-29-10R1-N	89	49	40	47	10
9.5	–	29	02691575	SD203A-9.5-29-10R1-N	89	49	40	47	10
9.525	3/8	31	02691576	SD203A-03750-122-0394R1-N	89	49	40	47	10
10.0	–	31	02691577	SD203A-10.0-31-10R1-N	89	49	40	47	10
10.2	–	31	02691578	SD203A-10.2-31-12R1-N	102	57	45	55	12
10.32	13/32	31	02691579	SD203A-04063-122-0472R1-N	102	57	45	55	12
10.5	–	31	02691580	SD203A-10.5-31-12R1-N	102	57	45	55	12
11.0	–	33	02691582	SD203A-11.0-33-12R1-N	102	57	45	55	12
11.113	7/16	33	02691585	SD203A-04375-130-0472R1-N	102	57	45	55	12
11.5	–	33	02691588	SD203A-11.5-33-12R1-N	102	57	45	55	12
12.0	–	36	02691589	SD203A-12.0-36-12R1-N	102	57	45	55	12
12.5	–	36	02691591	SD203A-12.5-36-14R1-N	107	62	45	60	14
12.7	1/2	36	02691592	SD203A-05000-142-0551R1-N	107	62	45	60	14
13.0	–	36	02691594	SD203A-13.0-36-14R1-N	107	62	45	60	14
13.492	17/32	37	02691596	SD203A-05312-146-0551R1-N	107	62	45	60	14
13.5	–	37	02691597	SD203A-13.5-37-14R1-N	107	62	45	60	14
14.0	–	37	02691598	SD203A-14.0-37-14R1-N	107	62	45	60	14

For intermediate diameters see Custom Design software.

Composite machining

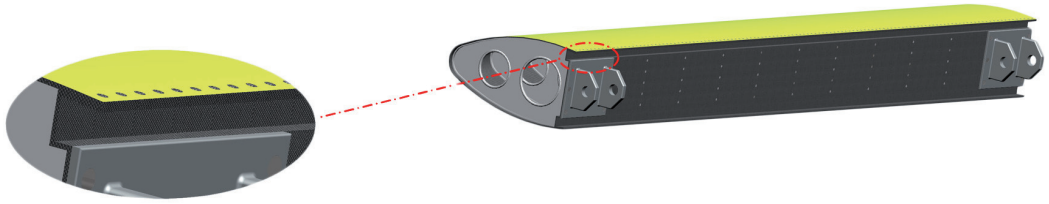

When hole quality is in focus

With issues like entrance and exit delamination and splintering, the focus has been clear; design tools specifically optimized for composite applications, and tools specifically optimised for sandwich materials. In both cases particular consideration was given to achieving excellent performance in both entering and exiting. (In sandwich material this usually involves exiting in either Al or Ti).

- No push-up delamination (entrance)
- No pull-down delamination (exit)

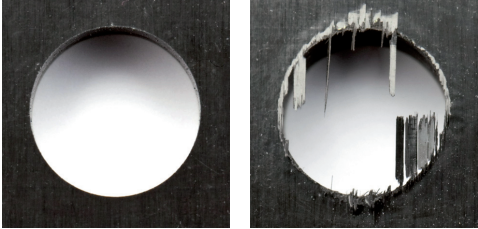

The Dura diamond coating secures good dimensional tolerance throughout the long tool life.

Application example

Plain CFRP/GFRP (exit in composite material)

CX1 geometry



Sandwich material (exit in Al/Ti)

CX2 geometry



CX31 geometry PCD
Universal geometry for both
Plain CFRP/GFRP and
Sandwich materials



Troubleshooting

Hole exit

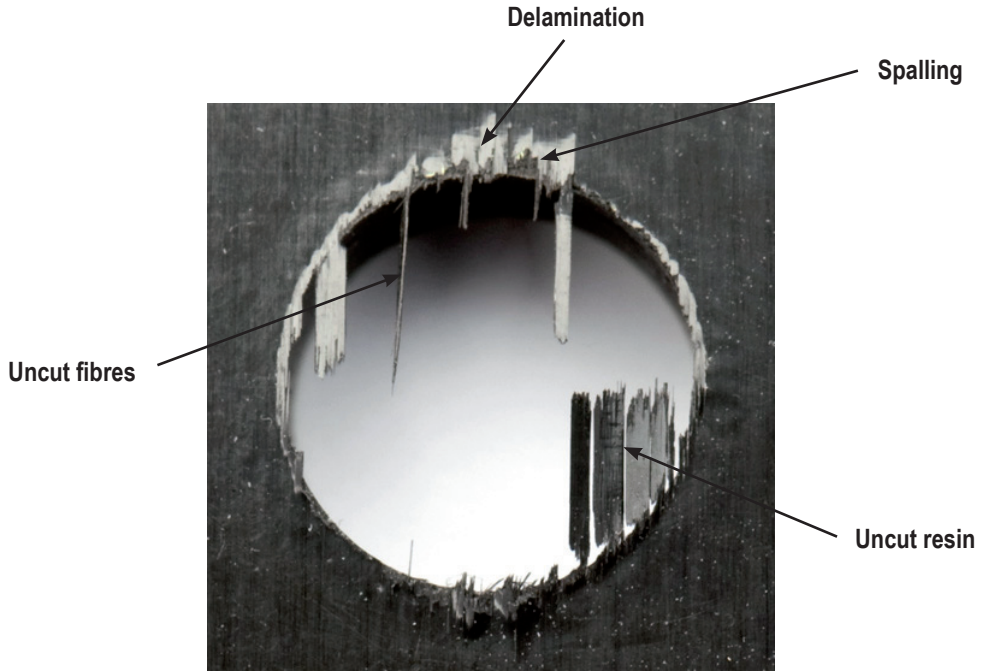

Problem:	Delamination (peel up / push down)	Spalling	Uncut fibres	Uncut resin
Solution:	Peel up <ul style="list-style-type: none"> • Use tool with more negative geometry • Reduce feed/rev. 	<ul style="list-style-type: none"> • Use tool with more positive geometry • Reduce feed/rev. 	<ul style="list-style-type: none"> • Use tool with a sharper geometry • Reduce feed/rev. 	<ul style="list-style-type: none"> • Use tool with a sharper geometry • Reduce feed/rev. • Reduce cutting speed
	Push down <ul style="list-style-type: none"> • Reduce feed/rev. 			
Problem:	Melted resin Too much heat	Poor tool life		
Solution:	<ul style="list-style-type: none"> • Reduce cutting speed 	<ul style="list-style-type: none"> • Reduce cutting speed 		

Drilling depth ~ 5 x D

Cylindrical shank DIN 6537A



- Internal coolant
- Point angle: 140°/180°
- Dura diamond coating
- For cutting data see page(s) 104-105

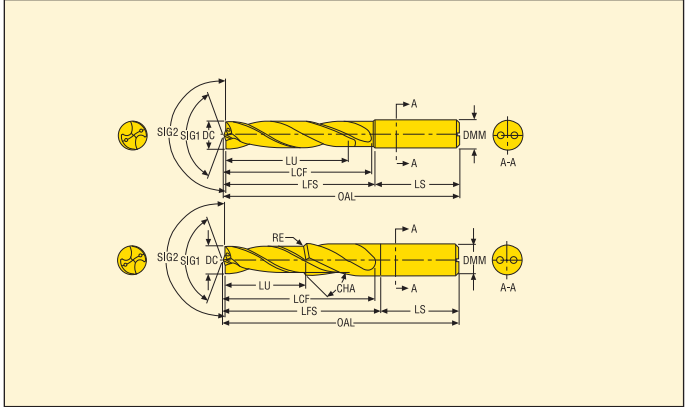

DC (mm)	DC (inch)	Expected hole tolerance	Manufacturing tolerance drill	LU	Ordering and Product No.	Designation	Dimensions in mm				
							OAL	LFS	LS	LCF	DMM
6,0	–	5,975/6,025	6,000 m7	32	02740099	SD205A-6.0-32-6R1-C2	82	46	36	44	6
9,55	3/8	9,525/9,576	9,551 m7	48	02740103	SD205A-9.55-48-10R1-C2	103	63	40	61	10

Drilling depth ~ 3 x D

Cylindrical shank DIN 6537A



- PCD cutting edges.
- Point angle: 120°/180°
- For cutting data see page(s) 102-103

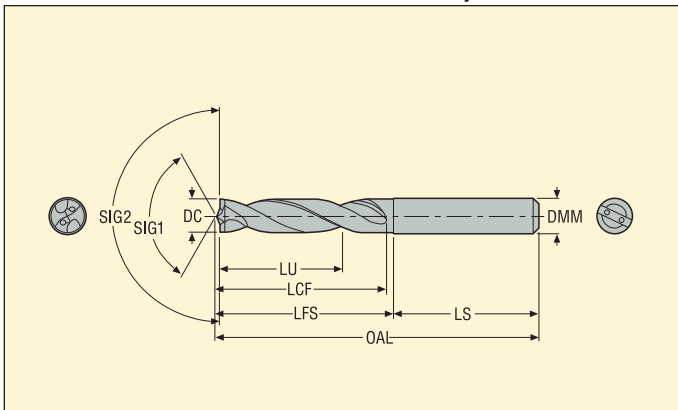

DC (mm)	DC (inch)	Expected hole tolerance	Manufacturing tolerance drill	LU	Ordering and Product No.	Designation	Dimensions in mm				
							OAL	LFS	LS	LCF	DMM
3,26	.128	3,235/3,285	3,260 m7	14	02827930	SD203A-3.26-14-6R1-CX2	62	26	36	20	6
4,17	.164	4,142/4,192	4,167 m7	17	02827931	SD203A-4.17-17-6R1-CX2	66	30	36	24	6
4,83	.190	4,805/4,855	4,830 m7	20	02827932	SD203A-4.83-20-6R1-CX2	66	30	36	28	6
6,06	.239	6,035/6,085	6,060 m7	21	02827933	SD203A-6.06-21-6R1-CX2	66	30	36	28	6
6,36	.250	6,33/6,38	6,355 m7	23	02827934	SD203A-6.36-23-8R1-CX2	79	43	36	34	8
7,94	.313	7,913/7,963	7,938 m7	27	02827935	SD203A-7.94-27-8R1-CX2	79	43	36	41	8
9,53	.375	9,504/9,554	9,529 m7	31	02827936	SD203A-9.53-31-10R1-CX2	89	49	40	47	10

Drilling depth ~ 5 x D

Cylindrical shank DIN 6537A



- PCD cutting edges.
- Point angle: 120°
- For cutting data see page(s) 104

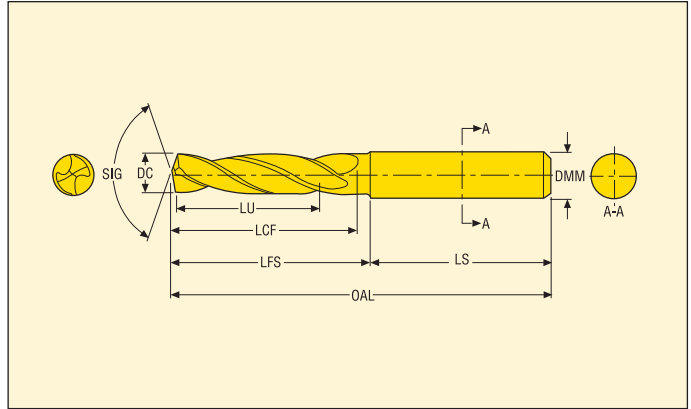

DC (mm)	DC (inch)	Expected hole tolerance	Manufacturing tolerance drill	LU	Ordering and Product No.	Designation	Dimensions in mm				
							OAL	LFS	LS	LCF	DMM
4,1	–	4,075/4,125	4,100 m7	26	02780522	SD205-4.10-26-6R1-CX31	74	38	36	37	6
4,78	3/16	4,755/4,805	4,780 m7	31	02780523	SD205-4.78-31-6R1-CX31	82	46	36	44	6
6,0	–	5,975/6,025	6,000 m7	31	02780524	SD205-6.00-31-6R1-CX31	82	46	36	44	6
6,38	1/4	6,350/6,401	6,376 m7	34	02780525	SD205-6.38-34-8R1-CX31	91	55	36	53	8
7,963	5/16	7,938/7,988	7,963 m7	40	02780527	SD205-7.963-40-8R1-CX31	91	55	36	53	8

Micro drill



Drilling depth ~ 2 x D (Pilot drill)

Cylindrical shank



- External coolant
- Point angle: 130°
- Uncoated
- For cutting data see page(s) 112-114

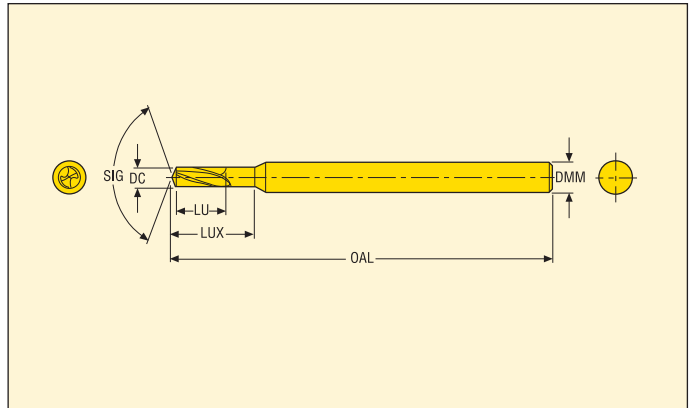

DC	LU	Ordering and Product No.	Designation	Dimensions in mm		
				OAL	LUX	DMM
0,1	0,2	02731574	SD22-0.10-0.20-3R1	38	0,55	3
0,11	0,22	02730362	SD22-0.11-0.22-3R1	38	0,55	3
0,12	0,24	02730460	SD22-0.12-0.24-3R1	38	0,55	3
0,13	0,26	02730461	SD22-0.13-0.26-3R1	38	0,6	3
0,14	0,28	02730462	SD22-0.14-0.28-3R1	38	0,6	3
0,15	0,3	02731575	SD22-0.15-0.30-3R1	38	0,6	3
0,16	0,32	02730464	SD22-0.16-0.32-3R1	38	0,6	3
0,17	0,34	02730465	SD22-0.17-0.34-3R1	38	0,7	3
0,18	0,36	02730466	SD22-0.18-0.36-3R1	38	0,7	3
0,19	0,38	02730467	SD22-0.19-0.38-3R1	38	0,7	3
0,2	0,4	02731576	SD22-0.20-0.40-3R1	38	0,75	3
0,21	0,42	02730468	SD22-0.21-0.42-3R1	38	0,75	3
0,22	0,44	02730469	SD22-0.22-0.44-3R1	38	0,8	3
0,23	0,46	02730470	SD22-0.23-0.46-3R1	38	0,8	3
0,24	0,48	02730471	SD22-0.24-0.48-3R1	38	0,8	3
0,25	0,5	02731577	SD22-0.25-0.50-3R1	38	0,9	3
0,26	0,52	02730472	SD22-0.26-0.52-3R1	38	0,9	3
0,27	0,54	02730473	SD22-0.27-0.54-3R1	38	0,9	3
0,28	0,56	02730474	SD22-0.28-0.56-3R1	38	1,0	3
0,29	0,58	02730475	SD22-0.29-0.58-3R1	38	1,0	3
0,3	0,6	02731579	SD22-0.30-0.60-3R1	38	1,2	3
0,31	0,62	02730476	SD22-0.31-0.62-3R1	38	1,2	3
0,32	0,64	02730477	SD22-0.32-0.64-3R1	38	1,2	3
0,33	0,66	02730478	SD22-0.33-0.66-3R1	38	1,2	3
0,34	0,68	02730479	SD22-0.34-0.68-3R1	38	1,35	3
0,35	0,7	02731580	SD22-0.35-0.70-3R1	38	1,35	3
0,36	0,72	02730480	SD22-0.36-0.72-3R1	38	1,35	3
0,37	0,74	02730481	SD22-0.37-0.74-3R1	38	1,35	3
0,38	0,76	02730482	SD22-0.38-0.76-3R1	38	1,5	3
0,39	0,78	02730483	SD22-0.39-0.78-3R1	38	1,5	3
0,4	0,8	02731581	SD22-0.40-0.80-3R1	38	1,6	3
0,41	0,82	02730484	SD22-0.41-0.82-3R1	38	1,6	3
0,42	0,84	02730485	SD22-0.42-0.84-3R1	38	1,6	3
0,43	0,86	02730486	SD22-0.43-0.86-3R1	38	1,6	3
0,44	0,88	02730487	SD22-0.44-0.88-3R1	38	1,6	3
0,45	0,9	02731582	SD22-0.45-0.90-3R1	38	1,6	3
0,46	0,92	02730488	SD22-0.46-0.92-3R1	38	1,7	3
0,47	0,94	02730489	SD22-0.47-0.94-3R1	38	1,7	3
0,48	0,96	02730490	SD22-0.48-0.96-3R1	38	1,7	3
0,49	0,98	02730491	SD22-0.49-0.98-3R1	38	1,7	3
0,5	1,0	02731584	SD22-0.50-1.00-3R1	38	1,7	3
0,51	1,02	02730492	SD22-0.51-1.02-3R1	38	1,8	3

Drilling depth ~ 2 x D (Pilot drill)

Cylindrical shank



- External coolant
- Point angle: 130°
- Uncoated
- For cutting data see page(s) 112-114

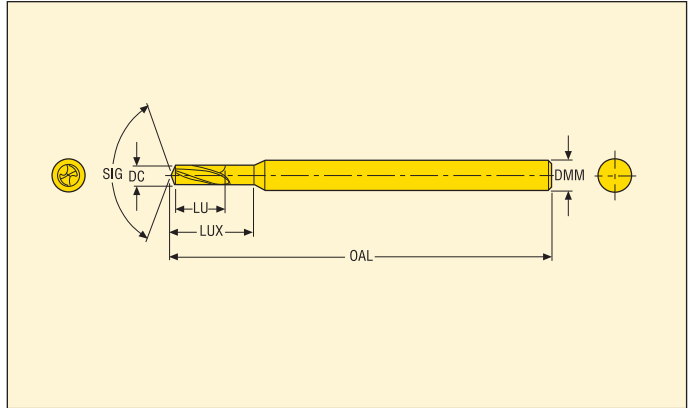

DC	LU	Ordering and Product No.	Designation	Dimensions in mm		
				OAL	LUX	DMM
0,52	1,04	02730493	SD22-0.52-1.04-3R1	38	1,8	3
0,53	1,06	02730494	SD22-0.53-1.06-3R1	38	1,8	3
0,54	1,08	02730495	SD22-0.54-1.08-3R1	38	1,8	3
0,55	1,1	02731585	SD22-0.55-1.10-3R1	38	1,8	3
0,56	1,12	02730496	SD22-0.56-1.12-3R1	38	1,9	3
0,57	1,14	02730497	SD22-0.57-1.14-3R1	38	1,9	3
0,58	1,16	02730498	SD22-0.58-1.16-3R1	38	1,9	3
0,59	1,18	02730499	SD22-0.59-1.18-3R1	38	1,9	3
0,6	1,2	02731586	SD22-0.60-1.20-3R1	38	1,9	3
0,61	1,22	02730500	SD22-0.61-1.22-3R1	38	2,0	3
0,62	1,24	02730501	SD22-0.62-1.24-3R1	38	2,0	3
0,63	1,26	02730502	SD22-0.63-1.26-3R1	38	2,0	3
0,64	1,28	02730503	SD22-0.64-1.28-3R1	38	2,0	3
0,65	1,3	02731587	SD22-0.65-1.30-3R1	38	2,0	3
0,66	1,32	02730504	SD22-0.66-1.32-3R1	38	2,1	3
0,67	1,34	02730505	SD22-0.67-1.34-3R1	38	2,1	3
0,68	1,36	02730506	SD22-0.68-1.36-3R1	38	2,1	3
0,69	1,38	02730507	SD22-0.69-1.38-3R1	38	2,1	3
0,7	1,4	02731589	SD22-0.70-1.40-3R1	38	2,1	3
0,71	1,42	02730508	SD22-0.71-1.42-3R1	38	2,2	3
0,72	1,44	02730509	SD22-0.72-1.44-3R1	38	2,2	3
0,73	1,46	02730510	SD22-0.73-1.46-3R1	38	2,2	3
0,74	1,48	02730511	SD22-0.74-1.48-3R1	38	2,2	3
0,75	1,5	02731590	SD22-0.75-1.50-3R1	38	2,2	3
0,76	1,52	02730512	SD22-0.76-1.52-3R1	38	2,3	3
0,77	1,54	02730513	SD22-0.77-1.54-3R1	38	2,3	3
0,78	1,56	02730514	SD22-0.78-1.56-3R1	38	2,3	3
0,79	1,58	02730515	SD22-0.79-1.58-3R1	38	2,3	3
0,8	1,6	02731592	SD22-0.80-1.60-3R1	38	2,3	3
0,81	1,62	02730516	SD22-0.81-1.62-3R1	38	2,4	3
0,82	1,64	02730517	SD22-0.82-1.64-3R1	38	2,4	3
0,83	1,66	02730518	SD22-0.83-1.66-3R1	38	2,4	3
0,84	1,68	02730519	SD22-0.84-1.68-3R1	38	2,4	3
0,85	1,7	02731593	SD22-0.85-1.70-3R1	38	2,4	3
0,86	1,72	02730520	SD22-0.86-1.72-3R1	38	2,5	3
0,87	1,74	02730521	SD22-0.87-1.74-3R1	38	2,5	3
0,88	1,76	02730522	SD22-0.88-1.76-3R1	38	2,5	3
0,89	1,78	02730523	SD22-0.89-1.78-3R1	38	2,5	3
0,9	1,8	02731594	SD22-0.90-1.80-3R1	38	2,5	3
0,91	1,82	02730524	SD22-0.91-1.82-3R1	38	2,6	3
0,92	1,84	02730525	SD22-0.92-1.84-3R1	38	2,6	3
0,93	1,86	02730526	SD22-0.93-1.86-3R1	38	2,6	3

Drilling depth ~ 2 x D (Pilot drill)

Cylindrical shank



- External coolant
- Point angle: 130°
- Uncoated
- For cutting data see page(s) 112-114

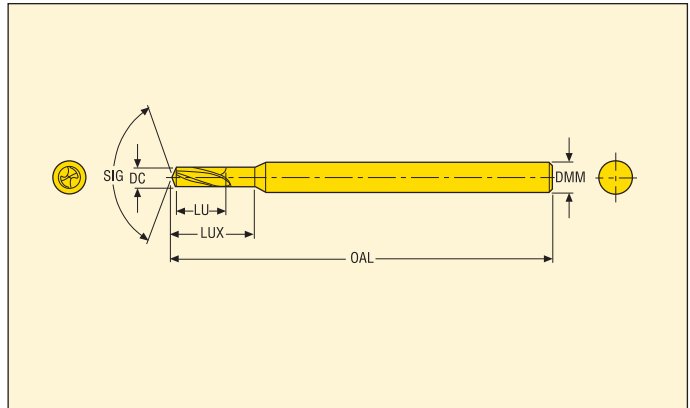

DC	LU	Ordering and Product No.	Designation	Dimensions in mm		
				OAL	LUX	DMM
0,94	1,88	02730527	SD22-0.94-1.88-3R1	38	2,6	3
0,95	1,9	02731595	SD22-0.95-1.90-3R1	38	2,6	3
0,96	1,92	02730528	SD22-0.96-1.92-3R1	38	2,7	3
0,97	1,94	02730529	SD22-0.97-1.94-3R1	38	2,7	3
0,98	1,96	02730530	SD22-0.98-1.96-3R1	38	2,7	3
0,99	1,98	02730531	SD22-0.99-1.98-3R1	38	2,7	3
1,0	2,0	02731596	SD22-1.00-2.00-3R1	38	2,7	3
1,01	2,02	02730532	SD22-1.01-2.02-3R1	38	3,5	3
1,02	2,04	02730533	SD22-1.02-2.04-3R1	38	3,5	3
1,03	2,06	02730534	SD22-1.03-2.06-3R1	38	3,5	3
1,04	2,08	02730535	SD22-1.04-2.08-3R1	38	3,5	3
1,05	2,1	02730536	SD22-1.05-2.10-3R1	38	3,5	3
1,06	2,12	02730537	SD22-1.06-2.12-3R1	38	3,6	3
1,07	2,14	02730538	SD22-1.07-2.14-3R1	38	3,6	3
1,08	2,16	02730539	SD22-1.08-2.16-3R1	38	3,6	3
1,09	2,18	02730540	SD22-1.09-2.18-3R1	38	3,6	3
1,1	2,2	02731598	SD22-1.10-2.20-3R1	38	3,6	3
1,11	2,22	02730541	SD22-1.11-2.22-3R1	38	3,7	3
1,12	2,24	02730542	SD22-1.12-2.24-3R1	38	3,7	3
1,13	2,26	02730543	SD22-1.13-2.26-3R1	38	3,7	3
1,14	2,28	02730544	SD22-1.14-2.28-3R1	38	3,7	3
1,15	2,3	02730545	SD22-1.15-2.30-3R1	38	3,7	3
1,16	2,32	02730546	SD22-1.16-2.32-3R1	38	3,8	3
1,17	2,34	02730547	SD22-1.17-2.34-3R1	38	3,8	3
1,18	2,36	02730548	SD22-1.18-2.36-3R1	38	3,8	3
1,19	2,38	02730549	SD22-1.19-2.38-3R1	38	3,8	3
1,2	2,4	02731599	SD22-1.20-2.40-3R1	38	3,8	3
1,21	2,42	02730550	SD22-1.21-2.42-3R1	38	4,2	3
1,22	2,44	02730551	SD22-1.22-2.44-3R1	38	4,2	3
1,23	2,46	02730552	SD22-1.23-2.46-3R1	38	4,2	3
1,24	2,48	02730553	SD22-1.24-2.48-3R1	38	4,2	3
1,25	2,5	02730554	SD22-1.25-2.50-3R1	38	4,2	3
1,26	2,52	02730555	SD22-1.26-2.52-3R1	38	4,3	3
1,27	2,54	02730556	SD22-1.27-2.54-3R1	38	4,3	3
1,28	2,56	02730557	SD22-1.28-2.56-3R1	38	4,3	3
1,29	2,58	02730558	SD22-1.29-2.58-3R1	38	4,3	3
1,3	2,6	02731600	SD22-1.30-2.60-3R1	38	4,3	3
1,31	2,62	02730559	SD22-1.31-2.62-3R1	38	4,4	3
1,32	2,64	02730560	SD22-1.32-2.64-3R1	38	4,4	3
1,33	2,66	02730561	SD22-1.33-2.66-3R1	38	4,4	3
1,34	2,68	02730562	SD22-1.34-2.68-3R1	38	4,4	3
1,35	2,7	02730563	SD22-1.35-2.70-3R1	38	4,4	3

Drilling depth ~ 2 x D (Pilot drill)

Cylindrical shank

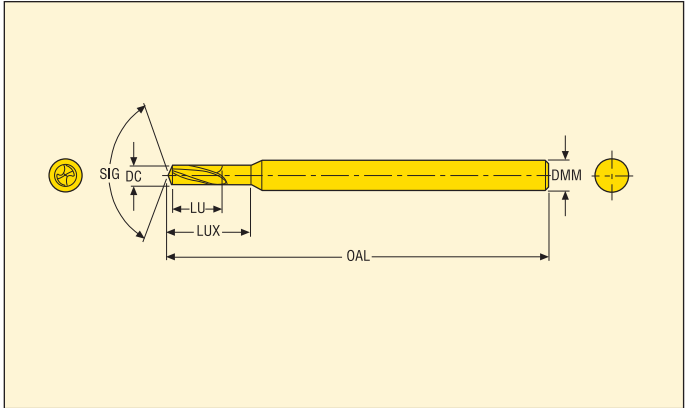

- External coolant
- Point angle: 130°
- Uncoated
- For cutting data see page(s) 112-114

DC	LU	Ordering and Product No.	Designation	Dimensions in mm		
				OAL	LUX	DMM
1,36	2,72	02730564	SD22-1.36-2.72-3R1	38	4,5	3
1,37	2,74	02730565	SD22-1.37-2.74-3R1	38	4,5	3
1,38	2,76	02730566	SD22-1.38-2.76-3R1	38	4,5	3
1,39	2,78	02730567	SD22-1.39-2.78-3R1	38	4,5	3
1,4	2,8	02731602	SD22-1.40-2.80-3R1	38	4,5	3
1,41	2,82	02730568	SD22-1.41-2.82-3R1	38	4,6	3
1,42	2,84	02730569	SD22-1.42-2.84-3R1	38	4,6	3
1,43	2,86	02730570	SD22-1.43-2.86-3R1	38	4,6	3
1,44	2,88	02730571	SD22-1.44-2.88-3R1	38	4,6	3
1,45	2,9	02730572	SD22-1.45-2.90-3R1	38	4,6	3
1,46	2,92	02730573	SD22-1.46-2.92-3R1	38	4,7	3
1,47	2,94	02730574	SD22-1.47-2.94-3R1	38	4,7	3
1,48	2,96	02730575	SD22-1.48-2.96-3R1	38	4,7	3
1,49	2,98	02730576	SD22-1.49-2.98-3R1	38	4,7	3
1,5	3,0	02731603	SD22-1.50-3.00-3R1	38	4,7	3
1,51	3,02	02730577	SD22-1.51-3.02-3R1	38	5,1	3
1,52	3,04	02730578	SD22-1.52-3.04-3R1	38	5,1	3
1,53	3,06	02730579	SD22-1.53-3.06-3R1	38	5,1	3
1,54	3,08	02730580	SD22-1.54-3.08-3R1	38	5,1	3
1,55	3,1	02730581	SD22-1.55-3.10-3R1	38	5,1	3
1,56	3,12	02730582	SD22-1.56-3.12-3R1	38	5,2	3
1,57	3,14	02730583	SD22-1.57-3.14-3R1	38	5,2	3
1,58	3,16	02730584	SD22-1.58-3.16-3R1	38	5,2	3
1,59	3,18	02730585	SD22-1.59-3.18-3R1	38	5,2	3
1,6	3,2	02731605	SD22-1.60-3.20-3R1	38	5,2	3
1,61	3,22	02730586	SD22-1.61-3.22-3R1	38	5,3	3
1,62	3,24	02730587	SD22-1.62-3.24-3R1	38	5,3	3
1,63	3,26	02730588	SD22-1.63-3.26-3R1	38	5,3	3
1,64	3,28	02730589	SD22-1.64-3.28-3R1	38	5,3	3
1,65	3,3	02730590	SD22-1.65-3.30-3R1	38	5,3	3
1,66	3,32	02730592	SD22-1.66-3.32-3R1	38	5,4	3
1,67	3,34	02730593	SD22-1.67-3.34-3R1	38	5,4	3
1,68	3,36	02730594	SD22-1.68-3.36-3R1	38	5,4	3
1,69	3,38	02730595	SD22-1.69-3.38-3R1	38	5,4	3
1,7	3,4	02731606	SD22-1.70-3.40-3R1	38	5,4	3
1,71	3,42	02730596	SD22-1.71-3.42-3R1	38	5,5	3
1,72	3,44	02730597	SD22-1.72-3.44-3R1	38	5,5	3
1,73	3,46	02730598	SD22-1.73-3.46-3R1	38	5,5	3
1,74	3,48	02730599	SD22-1.74-3.48-3R1	38	5,5	3
1,75	3,5	02730601	SD22-1.75-3.50-3R1	38	5,5	3
1,76	3,52	02730602	SD22-1.76-3.52-3R1	38	5,6	3
1,77	3,54	02730603	SD22-1.77-3.54-3R1	38	5,6	3

Drilling depth ~ 2 x D (Pilot drill)

Cylindrical shank

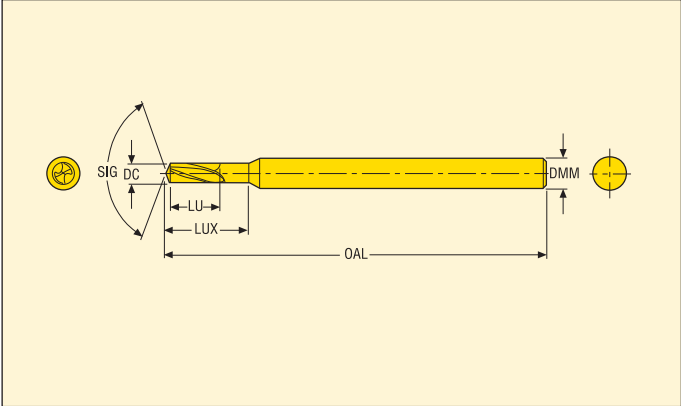

- External coolant
- Point angle: 130°
- Uncoated
- For cutting data see page(s) 112-114

DC	LU	Ordering and Product No.	Designation	Dimensions in mm		
				OAL	LUX	DMM
1,78	3,56	02730604	SD22-1.78-3.56-3R1	38	5,6	3
1,79	3,58	02730605	SD22-1.79-3.58-3R1	38	5,6	3
1,8	3,6	02731607	SD22-1.80-3.60-3R1	38	5,6	3
1,81	3,62	02730606	SD22-1.81-3.62-3R1	38	5,7	3
1,82	3,64	02730607	SD22-1.82-3.64-3R1	38	5,7	3
1,83	3,66	02730608	SD22-1.83-3.66-3R1	38	5,7	3
1,84	3,68	02730609	SD22-1.84-3.68-3R1	38	5,7	3
1,85	3,7	02730610	SD22-1.85-3.70-3R1	38	5,7	3
1,86	3,72	02730611	SD22-1.86-3.72-3R1	38	5,8	3
1,87	3,74	02730612	SD22-1.87-3.74-3R1	38	5,8	3
1,88	3,76	02730613	SD22-1.88-3.76-3R1	38	5,8	3
1,89	3,78	02730614	SD22-1.89-3.78-3R1	38	5,8	3
1,9	3,8	02731609	SD22-1.90-3.80-3R1	38	5,8	3
1,91	3,82	02730615	SD22-1.91-3.82-3R1	38	5,9	3
1,92	3,84	02730616	SD22-1.92-3.84-3R1	38	5,9	3
1,93	3,86	02730617	SD22-1.93-3.86-3R1	38	5,9	3
1,94	3,88	02730618	SD22-1.94-3.88-3R1	38	5,9	3
1,95	3,9	02730619	SD22-1.95-3.90-3R1	38	5,9	3
1,96	3,92	02730620	SD22-1.96-3.92-3R1	38	6,0	3
1,97	3,94	02730621	SD22-1.97-3.94-3R1	38	6,0	3
1,98	3,96	02730622	SD22-1.98-3.96-3R1	38	6,0	3
1,99	3,98	02730623	SD22-1.99-3.98-3R1	38	6,0	3
2,0	4,0	02731610	SD22-2.00-4.00-3R1	38	6,0	3

Drilling depth ~ 6 x D

Cylindrical shank



- External coolant
- Point angle: 130°
- Uncoated
- For cutting data see page(s) 112-114

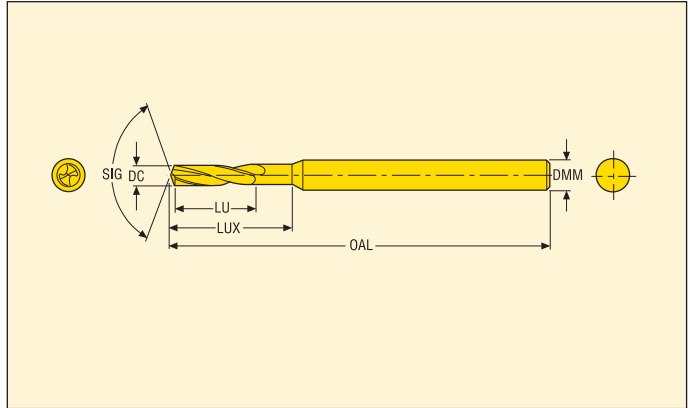

DC	LU	Ordering and Product No.	Designation	Dimensions in mm		
				OAL	LUX	DMM
0,1	0,4	02731612	SD26-0.10-0.40-3R1	38	0,7	3
0,11	0,4	02730624	SD26-0.11-0.40-3R1	38	0,7	3
0,12	0,4	02730625	SD26-0.12-0.40-3R1	38	0,7	3
0,13	0,65	02730626	SD26-0.13-0.65-3R1	38	1,0	3
0,14	0,65	02730627	SD26-0.14-0.65-3R1	38	1,0	3
0,15	0,9	02731613	SD26-0.15-0.65-3R1	38	1,4	3
0,16	0,9	02730628	SD26-0.16-0.90-3R1	38	1,4	3
0,17	0,9	02730629	SD26-0.17-0.90-3R1	38	1,4	3
0,18	0,9	02730630	SD26-0.18-0.90-3R1	38	1,4	3
0,19	0,9	02730631	SD26-0.19-0.90-3R1	38	1,4	3
0,2	1,25	02731615	SD26-0.20-1.25-3R1	38	1,8	3
0,21	1,25	02730632	SD26-0.21-1.25-3R1	38	1,8	3
0,22	1,25	02730633	SD26-0.22-1.25-3R1	38	1,8	3
0,23	1,25	02730634	SD26-0.23-1.25-3R1	38	1,8	3
0,24	1,25	02730635	SD26-0.24-1.25-3R1	38	1,8	3
0,25	1,55	02731617	SD26-0.25-1.55-3R1	38	2,2	3
0,26	1,55	02730636	SD26-0.26-1.55-3R1	38	2,2	3
0,27	1,55	02730637	SD26-0.27-1.55-3R1	38	2,2	3
0,28	1,55	02730638	SD26-0.28-1.55-3R1	38	2,2	3
0,29	1,55	02730639	SD26-0.29-1.55-3R1	38	2,2	3
0,3	1,8	02731618	SD26-0.30-1.80-3R1	38	2,4	3
0,31	1,8	02730640	SD26-0.31-1.80-3R1	38	2,4	3
0,32	1,8	02730641	SD26-0.32-1.80-3R1	38	2,4	3
0,33	1,8	02730642	SD26-0.33-1.80-3R1	38	2,4	3
0,34	1,8	02730643	SD26-0.34-1.80-3R1	38	2,4	3
0,35	2,2	02731619	SD26-0.35-2.20-3R1	38	2,8	3
0,36	2,2	02730644	SD26-0.36-2.20-3R1	38	2,8	3
0,37	2,2	02730645	SD26-0.37-2.20-3R1	38	2,8	3
0,38	2,2	02730646	SD26-0.38-2.20-3R1	38	2,8	3
0,39	2,7	02730647	SD26-0.39-2.70-3R1	38	3,6	3
0,4	2,7	02731620	SD26-0.40-2.70-3R1	38	3,6	3
0,41	2,7	02730648	SD26-0.41-2.70-3R1	38	3,6	3
0,42	2,7	02730649	SD26-0.42-2.70-3R1	38	3,6	3
0,43	2,7	02730650	SD26-0.43-2.70-3R1	38	3,6	3
0,44	2,7	02730651	SD26-0.44-2.70-3R1	38	3,6	3
0,45	2,7	02731621	SD26-0.45-2.70-3R1	38	3,6	3
0,46	2,7	02730652	SD26-0.46-2.70-3R1	38	3,6	3
0,47	2,7	02730653	SD26-0.47-2.70-3R1	38	3,6	3
0,48	2,7	02730654	SD26-0.48-2.70-3R1	38	3,6	3
0,49	3,2	02730655	SD26-0.49-3.20-3R1	38	4,0	3
0,5	3,2	02731622	SD26-0.50-3.20-3R1	38	4,0	3
0,51	3,2	02730656	SD26-0.51-3.20-3R1	38	4,0	3

Drilling depth ~ 6 x D

Cylindrical shank



- External coolant
- Point angle: 130°
- Uncoated
- For cutting data see page(s) 112-114

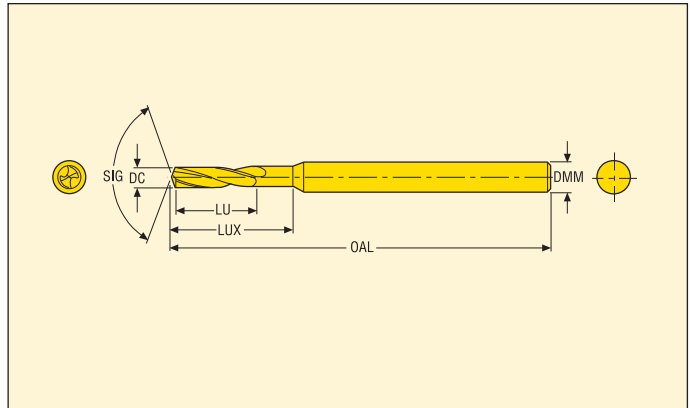

DC	LU	Ordering and Product No.	Designation	Dimensions in mm		
				OAL	LUX	DMM
0,52	3,2	02730657	SD26-0.52-3.20-3R1	38	4,0	3
0,53	3,2	02730658	SD26-0.53-3.20-3R1	38	4,0	3
0,54	3,6	02730659	SD26-0.54-3.60-3R1	38	4,5	3
0,55	3,6	02731623	SD26-0.55-3.60-3R1	38	4,5	3
0,56	3,6	02730660	SD26-0.56-3.60-3R1	38	4,5	3
0,57	3,6	02730661	SD26-0.57-3.60-3R1	38	4,5	3
0,58	3,6	02730662	SD26-0.58-3.60-3R1	38	4,5	3
0,59	3,6	02730663	SD26-0.59-3.60-3R1	38	4,5	3
0,6	3,6	02731624	SD26-0.60-3.60-3R1	38	4,5	3
0,61	3,6	02730664	SD26-0.61-3.90-3R1	38	4,5	3
0,62	3,9	02730665	SD26-0.62-3.90-3R1	38	5,0	3
0,63	3,9	02730666	SD26-0.63-3.90-3R1	38	5,0	3
0,64	3,9	02730667	SD26-0.64-3.90-3R1	38	5,0	3
0,65	3,9	02731625	SD26-0.65-3.90-3R1	38	5,0	3
0,66	3,9	02730668	SD26-0.66-3.90-3R1	38	5,0	3
0,67	3,9	02730669	SD26-0.67-3.90-3R1	38	5,0	3
0,68	4,5	02730670	SD26-0.68-4.50-3R1	38	5,6	3
0,69	4,5	02730671	SD26-0.69-4.50-3R1	38	5,6	3
0,7	4,5	02731626	SD26-0.70-4.50-3R1	38	5,6	3
0,71	4,5	02730672	SD26-0.71-4.50-3R1	38	5,6	3
0,72	4,5	02730673	SD26-0.72-4.50-3R1	38	5,6	3
0,73	4,5	02730674	SD26-0.73-4.50-3R1	38	5,6	3
0,74	4,5	02730675	SD26-0.74-4.50-3R1	38	5,6	3
0,75	4,5	02731627	SD26-0.75-4.50-3R1	38	5,6	3
0,76	5,0	02730676	SD26-0.76-5.00-3R1	38	6,3	3
0,77	5,0	02730677	SD26-0.77-5.00-3R1	38	6,3	3
0,78	5,0	02730678	SD26-0.78-5.00-3R1	38	6,3	3
0,79	5,0	02730679	SD26-0.79-5.00-3R1	38	6,3	3
0,8	5,0	02731628	SD26-0.80-5.00-3R1	38	6,3	3
0,81	5,0	02730680	SD26-0.81-5.00-3R1	38	6,3	3
0,82	5,0	02730681	SD26-0.82-5.00-3R1	38	6,3	3
0,83	5,0	02730682	SD26-0.83-5.00-3R1	38	6,3	3
0,84	5,0	02730683	SD26-0.84-5.00-3R1	38	6,3	3
0,85	5,0	02731629	SD26-0.85-5.00-3R1	38	6,3	3
0,86	5,7	02730684	SD26-0.86-5.70-3R1	38	7,1	3
0,87	5,7	02730685	SD26-0.87-5.70-3R1	38	7,1	3
0,88	5,7	02730686	SD26-0.88-5.70-3R1	38	7,1	3
0,89	5,7	02730687	SD26-0.89-5.70-3R1	38	7,1	3
0,9	5,7	02731630	SD26-0.90-5.70-3R1	38	7,1	3
0,91	5,7	02730688	SD26-0.91-5.70-3R1	38	7,1	3
0,92	5,7	02730689	SD26-0.92-5.70-3R1	38	7,1	3
0,93	5,7	02730690	SD26-0.93-5.70-3R1	38	7,1	3

Drilling depth ~ 6 x D

Cylindrical shank

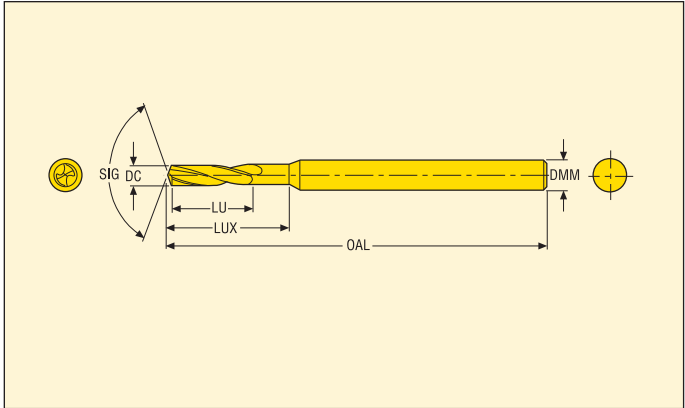

- External coolant
- Point angle: 130°
- Uncoated
- For cutting data see page(s) 112-114

DC	LU	Ordering and Product No.	Designation	Dimensions in mm		
				OAL	LUX	DMM
0,94	5,7	02730691	SD26-0.94-5.70-3R1	38	7,1	3
0,95	5,7	02731631	SD26-0.95-5.70-3R1	38	7,1	3
0,96	6,5	02730692	SD26-0.96-6.50-3R1	38	8,0	3
0,97	6,5	02730693	SD26-0.97-6.50-3R1	38	8,0	3
0,98	6,5	02730694	SD26-0.98-6.50-3R1	38	8,0	3
0,99	6,5	02730695	SD26-0.99-6.50-3R1	38	8,0	3
1,0	6,5	02731632	SD26-1.00-6.50-3R1	38	8,0	3
1,01	6,5	02730696	SD26-1.01-6.50-3R1	38	8,0	3
1,02	6,5	02730697	SD26-1.02-6.50-3R1	38	8,0	3
1,03	6,5	02730698	SD26-1.03-6.50-3R1	38	8,0	3
1,04	6,5	02730699	SD26-1.04-6.50-3R1	38	8,0	3
1,05	6,5	02730700	SD26-1.05-6.50-3R1	38	8,0	3
1,06	7,3	02730701	SD26-1.06-7.30-3R1	38	9,0	3
1,07	7,3	02730702	SD26-1.07-7.30-3R1	38	9,0	3
1,08	7,3	02730703	SD26-1.08-7.30-3R1	38	9,0	3
1,09	7,3	02730704	SD26-1.09-7.30-3R1	38	9,0	3
1,1	7,3	02731633	SD26-1.10-7.30-3R1	38	9,0	3
1,11	7,3	02730705	SD26-1.11-7.30-3R1	38	9,0	3
1,12	7,3	02730706	SD26-1.12-7.30-3R1	38	9,0	3
1,13	7,3	02730707	SD26-1.13-7.30-3R1	38	9,0	3
1,14	7,3	02730708	SD26-1.14-7.30-3R1	38	9,0	3
1,15	7,3	02730709	SD26-1.15-7.30-3R1	38	9,0	3
1,16	8,2	02730710	SD26-1.16-8.20-3R1	38	10,0	3
1,17	8,2	02730711	SD26-1.17-8.20-3R1	38	10,0	3
1,18	8,2	02730712	SD26-1.18-8.20-3R1	38	10,0	3
1,19	8,2	02730713	SD26-1.19-8.20-3R1	38	10,0	3
1,2	8,2	02731634	SD26-1.20-8.20-3R1	38	10,0	3
1,21	8,2	02730714	SD26-1.21-8.20-3R1	38	10,0	3
1,22	8,2	02730715	SD26-1.22-8.20-3R1	38	10,0	3
1,23	8,2	02730716	SD26-1.23-8.20-3R1	38	10,0	3
1,24	8,2	02730717	SD26-1.24-8.20-3R1	38	10,0	3
1,25	8,2	02730718	SD26-1.25-8.20-3R1	38	10,0	3
1,26	8,2	02730719	SD26-1.26-8.20-3R1	38	10,0	3
1,27	8,2	02730720	SD26-1.27-8.20-3R1	38	10,0	3
1,28	8,2	02730721	SD26-1.28-8.20-3R1	38	10,0	3
1,29	8,2	02730722	SD26-1.29-8.20-3R1	38	10,0	3
1,3	8,2	02731635	SD26-1.30-8.20-3R1	38	10,0	3
1,31	9,2	02730723	SD26-1.31-9.20-3R1	38	11,2	3
1,32	9,2	02730724	SD26-1.32-9.20-3R1	38	11,2	3
1,33	9,2	02730725	SD26-1.33-9.20-3R1	38	11,2	3
1,34	9,2	02730726	SD26-1.34-9.20-3R1	38	11,2	3
1,35	9,2	02730727	SD26-1.35-9.20-3R1	38	11,2	3

Drilling depth ~ 6 x D

Cylindrical shank



- External coolant
- Point angle: 130°
- Uncoated
- For cutting data see page(s) 112-114

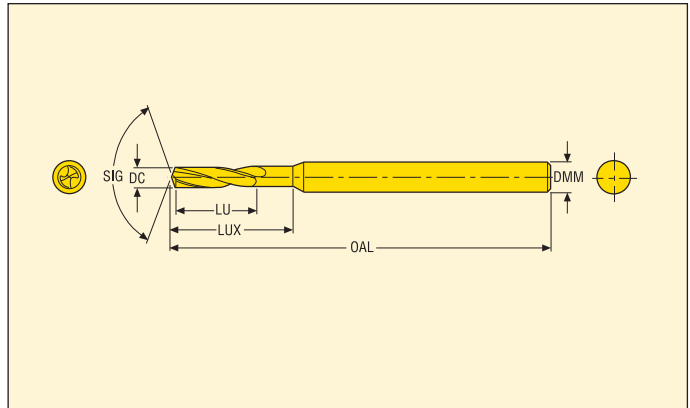

DC	LU	Ordering and Product No.	Designation	Dimensions in mm		
				OAL	LUX	DMM
1,36	9,2	02730728	SD26-1.36-9.20-3R1	38	11,2	3
1,37	9,2	02730729	SD26-1.37-9.20-3R1	38	11,2	3
1,38	9,2	02730730	SD26-1.38-9.20-3R1	38	11,2	3
1,39	9,2	02730731	SD26-1.39-9.20-3R1	38	11,2	3
1,4	9,2	02731637	SD26-1.40-9.20-3R1	38	11,2	3
1,41	9,2	02730732	SD26-1.41-9.20-3R1	38	11,2	3
1,42	9,2	02730733	SD26-1.42-9.20-3R1	38	11,2	3
1,43	9,2	02730734	SD26-1.43-9.20-3R1	38	11,2	3
1,44	9,2	02730735	SD26-1.44-9.20-3R1	38	11,2	3
1,45	9,2	02730736	SD26-1.45-9.20-3R1	38	11,2	3
1,46	9,2	02730737	SD26-1.46-9.20-3R1	38	11,2	3
1,47	9,2	02730738	SD26-1.47-9.20-3R1	38	11,2	3
1,48	9,2	02730739	SD26-1.48-9.20-3R1	38	11,2	3
1,49	9,2	02730740	SD26-1.49-9.20-3R1	38	11,2	3
1,5	9,2	02731638	SD26-1.50-9.20-3R1	38	11,2	3
1,51	11,2	02730741	SD26-1.51-11.20-3R1	38	13,4	3
1,52	11,2	02730742	SD26-1.52-11.20-3R1	38	13,4	3
1,53	11,2	02730743	SD26-1.53-11.20-3R1	38	13,4	3
1,54	11,2	02730744	SD26-1.54-11.20-3R1	38	13,4	3
1,55	11,2	02730745	SD26-1.55-11.20-3R1	38	13,4	3
1,56	11,2	02730746	SD26-1.56-11.20-3R1	38	13,4	3
1,57	11,2	02730747	SD26-1.57-11.20-3R1	38	13,4	3
1,58	11,2	02730748	SD26-1.58-11.20-3R1	38	13,4	3
1,59	11,2	02730749	SD26-1.59-11.20-3R1	38	13,4	3
1,6	11,2	02731639	SD26-1.60-11.20-3R1	38	13,4	3
1,61	11,2	02730750	SD26-1.61-11.20-3R1	38	13,4	3
1,62	11,2	02730751	SD26-1.62-11.20-3R1	38	13,4	3
1,63	11,2	02730752	SD26-1.63-11.20-3R1	38	13,4	3
1,64	11,2	02730753	SD26-1.64-11.20-3R1	38	13,4	3
1,65	11,2	02730754	SD26-1.65-11.20-3R1	38	13,4	3
1,66	11,2	02730755	SD26-1.66-11.20-3R1	38	13,4	3
1,67	11,2	02730756	SD26-1.67-11.20-3R1	38	13,4	3
1,68	11,2	02730757	SD26-1.68-11.20-3R1	38	13,4	3
1,69	11,2	02730758	SD26-1.69-11.20-3R1	38	13,4	3
1,7	11,2	02731640	SD26-1.70-11.20-3R1	38	13,4	3
1,71	11,2	02730759	SD26-1.71-11.20-3R1	38	13,4	3
1,72	11,2	02730760	SD26-1.72-11.20-3R1	38	13,4	3
1,73	11,2	02730761	SD26-1.73-11.20-3R1	38	13,4	3
1,74	11,2	02730762	SD26-1.74-11.20-3R1	38	13,4	3
1,75	11,2	02730763	SD26-1.75-11.20-3R1	38	13,4	3
1,76	11,2	02730764	SD26-1.76-11.20-3R1	38	13,4	3
1,77	11,2	02730765	SD26-1.77-11.20-3R1	38	13,4	3

Drilling depth ~ 6 x D

Cylindrical shank

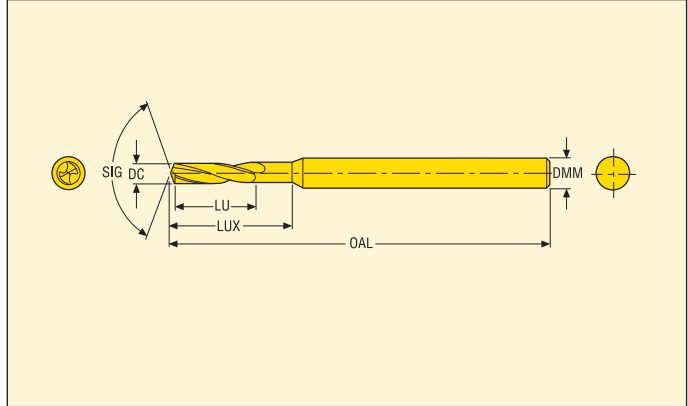

- External coolant
- Point angle: 130°
- Uncoated
- For cutting data see page(s) 112-114

DC	LU	Ordering and Product No.	Designation	Dimensions in mm		
				OAL	LUX	DMM
1,78	11,2	02730766	SD26-1.78-11.20-3R1	38	13,4	3
1,79	11,2	02730767	SD26-1.79-11.20-3R1	38	13,4	3
1,8	11,2	02731641	SD26-1.80-11.20-3R1	38	13,4	3
1,81	11,2	02730768	SD26-1.81-11.20-3R1	38	13,4	3
1,82	11,2	02730769	SD26-1.82-11.20-3R1	38	13,4	3
1,83	11,2	02730770	SD26-1.83-11.20-3R1	38	13,4	3
1,84	11,2	02730771	SD26-1.84-11.20-3R1	38	13,4	3
1,85	11,2	02730772	SD26-1.85-11.20-3R1	38	13,4	3
1,86	11,2	02730773	SD26-1.86-11.20-3R1	38	13,4	3
1,87	11,2	02730774	SD26-1.87-11.20-3R1	38	13,4	3
1,88	11,2	02730775	SD26-1.88-11.20-3R1	38	13,4	3
1,89	11,2	02730776	SD26-1.89-11.20-3R1	38	13,4	3
1,9	11,2	02731642	SD26-1.90-11.20-3R1	38	13,4	3
1,91	11,2	02730777	SD26-1.91-11.20-3R1	38	13,4	3
1,92	11,2	02730778	SD26-1.92-11.20-3R1	38	13,4	3
1,93	11,2	02730779	SD26-1.93-11.20-3R1	38	13,4	3
1,94	11,2	02730780	SD26-1.94-11.20-3R1	38	13,4	3
1,95	11,2	02730781	SD26-1.95-11.20-3R1	38	13,4	3
1,96	11,2	02730782	SD26-1.96-11.20-3R1	38	13,4	3
1,97	11,2	02730783	SD26-1.97-11.20-3R1	38	13,4	3
1,98	11,2	02730784	SD26-1.98-11.20-3R1	38	13,4	3
1,99	11,2	02730785	SD26-1.99-11.20-3R1	38	13,4	3
2,0	11,2	02731643	SD26-2.00-11.20-3R1	38	13,4	3

Custom design – No waiting for quotations! Price and delivery time available instantly!

A well defined strategy has been created for the total process for custom-made drills from quotation to finished drill. You can now design your own customised Seco Feedmax™ drill using the Custom Design software.

The concept gives you a number of advantages:

- No waiting for quotations! price and delivery time available instantly
- Directly visualises your needs. No risk of misunderstandings
- Short delivery time

CUSTOM DESIGN

Drilling >> Seco feedMAX® >> Single Diameter >> Chamfer >> Chamfer 4 Land margins
Feedback

Back
Start Page
English

[Print this page](#)

Step 1: Tool Specification
Step 2: Request for Quotation

	Min	Max	
Dc (m7)	3	19.5	<input type="text" value="12.2"/>
L4 (±0.2)	8	58	<input type="text" value="33.2"/>
Hole tolerances			H7-H8
Vch	15	84	<input type="text" value="45"/>
Type of shank			<input type="text" value="R1"/> ⓘ
Application			<input type="text" value="Universal"/> ⓘ
Through coolant			<input type="text" value="Yes"/>
Dmm (h6)			<input type="text" value="14"/>
Lc			45
L1			62
V			140
Coating			TiAlN

Designation
SD243A-C45-12.2-33.2-14R1

Delivery Time

Quantity:

Min Quantity: 2

Please contact your local Seco representative for more information.

89

Different types of custom drills – Detailed information can be found in the Custom Design software

A1. Single diameter

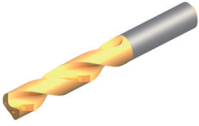

A2. Reinforced

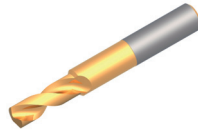

A3. Chamfer

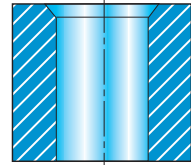
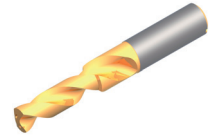

B1. Counterbore

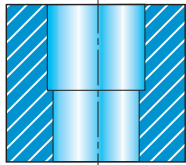
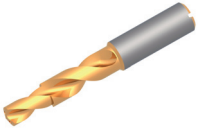

B2. Counterbore and chamfer

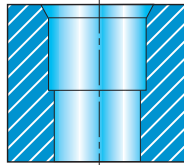
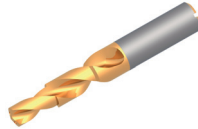

B3. Step

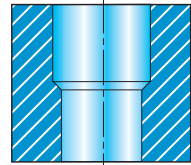
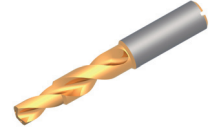

B4. Step and chamfer

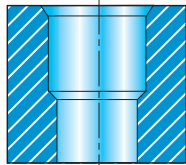
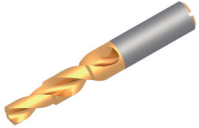

Machining data

Net power consumption

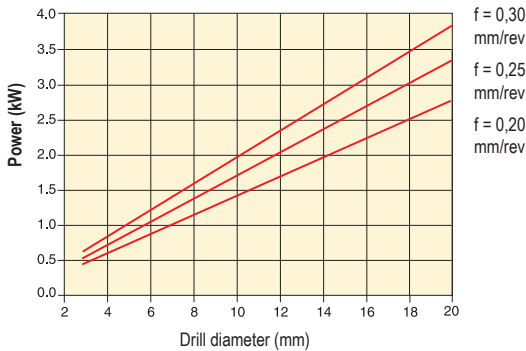

Coolant flow at different pressures

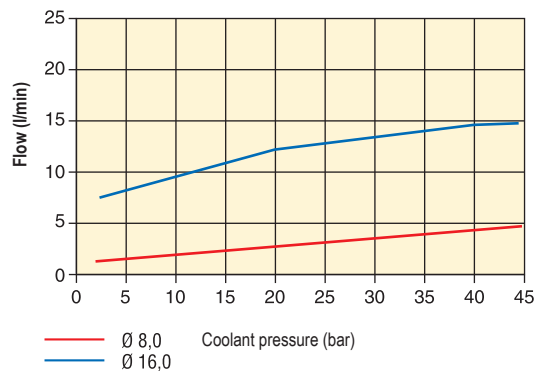

Feed force

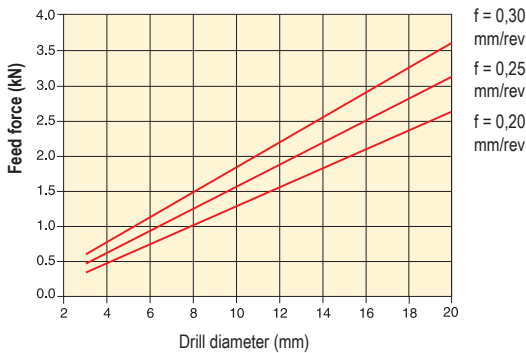

Method

Adjust feed up or down to obtain as good chip formation as possible. Increased feed/rev. gives shorter chips.

The values showing feed force and net power consumption above are basic values and vary with type of cutting data, material and tool wear.



Machining data

SD1103, SD1103A, SD1105A, SD203, SD203A, SD205A, SD206, SD206A, SD207A, SD216A, SD230A IT8-9/Ra 1-3*		
Drill Ø DC (mm)	IT9 tolerance (µm)	IT10 tolerance (µm)
<3	14	25
3-6	18	30
6-10	22	36
10-18	27	43
> 18	33	52

*Deterioration of surface finish can occur when drilling in low carbon steel or stainless steel.

Troubleshooting – Initial check points:

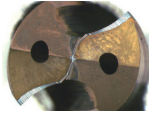
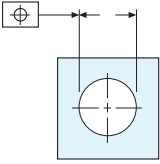
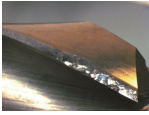
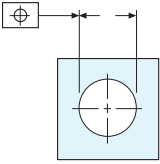
- Fixturing stability
- Machine spindle condition
- Tool holder condition
- Clamping of tool:
 - Run-out within 0,04 TIR
 - If using pre drilling within 0,04 TIR
- Chip evacuation:
 - Cutting data
- Coolant:
 - Pressure
 - Flow
 - Concentration

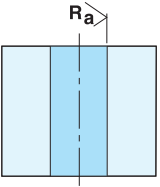
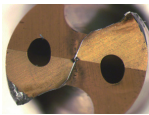
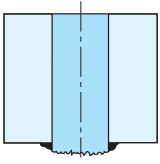
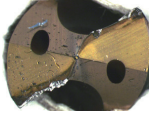
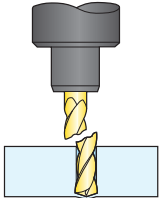
<p>Rapid flank wear</p> <ul style="list-style-type: none"> • Reduce the cutting speed • Increase coolant concentration 	<p>Unsatisfactory diameter tolerance</p> <ul style="list-style-type: none"> • Increase the feed/rev • Use a remaining operation, see page 231 • Use a boring operation, see page 387-388 
<p>Wear/Periphery land</p> <ul style="list-style-type: none"> • Reduce the cutting speed • Increase coolant concentration 	<p>Unsatisfactory positioning of the hole</p> <ul style="list-style-type: none"> • Reduce feed/rev. on entrance • Reduce feed/rev • Use a boring operation, see pages 387-388 • If drilling through rough, hard and angled surfaces - reduce the feed by 30%-50% during entrance and exit • Centre drill with a 140° point angle 
<p>Chipping/Centre</p> <ul style="list-style-type: none"> • Reduce feed during entrance • Increase coolant pressure and adjust the feed to optimize the chip formation 	<p>Unsatisfactory surface finish-Feedmax</p> <ul style="list-style-type: none"> • Reduce the feed/rev • Increase the cutting speed • Use a remaining operation, see page 231 
<p>Chipping/Outer corner, cutting edge</p> <ul style="list-style-type: none"> • Reduce feed during entrance/exit • Reduce the cutting speed • Increase coolant concentration • Regrind the drill 	<p>Burrs on exit</p> <ul style="list-style-type: none"> • Reduce the feed/rev. on exit • Reduce the width of edge preparation (BN) 
<p>Built-up edge</p> <ul style="list-style-type: none"> • If closer to the periphery increase the cutting speed • If closer to centre increase feed/rev • If the drill is worn, regrind it 	<p>Breakage on contact/at hole bottom</p> <ul style="list-style-type: none"> • Reduce the feed/rev. during entrance/exit • Adjust cutting data for improved chip evacuation 

Regrinding instructions for SD1103, SD1103A and SD1105A

1. Four facet point

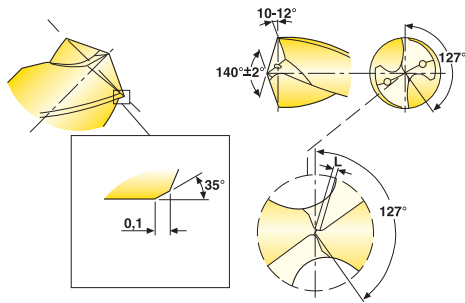

Lip height distance (axial run-out) to be within 0,02 mm

2. Web thinning

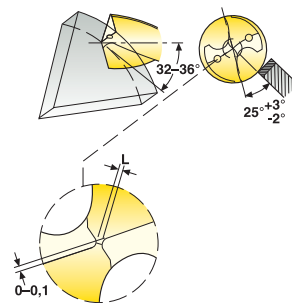

Drill Ø DC (mm)	L (mm)
2-10	0,1-0,3
10-20	0,2-0,4

3. Grinding of flat X

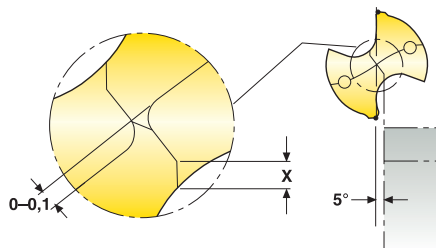

X = 0,08 x drill diameter DC

4. Edge preparation

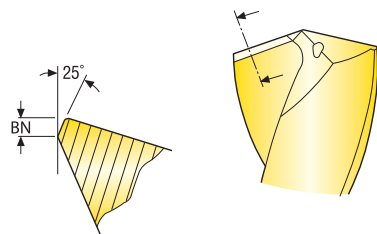

Workpiece material	BN (mm)	
	Drill Ø ≤10 (mm)	Drill Ø >10 (mm)
Steel	0,05	0,10
Stainless steel	0,05	0,05
Cast iron	0,05	0,10

Max. allowed flank wear before regrinding is 0,1-0,3 mm measured at the largest point.

Specifications

Proposed specification of diamond wheels:

- Conical clearance: Wheel shape 12A2 Grit size D54 (picture 1).
- Gashing: Wheel shape 1A1 or 1V1 Grit size D64-D46 (picture 2-3).
- Corner chamfer: Wheel shape 1A1 or 12A2 (picture 1).
- Edge treatment: grinding K-land or brushing (picture 4).

Important:

- The cutting edges must be uniform and have the same size of edge preparation.
- The edge preparation must be applied on the whole length of the cutting edges.

Regrinding instructions for SD203A, SD205A and SD207A -P geometry

1. Conical flank

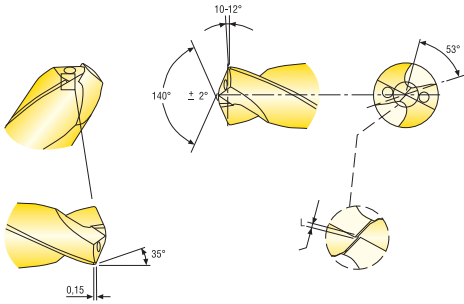

Lip height distance (axial run-out) to be within 0,02 mm

2. Web thinning

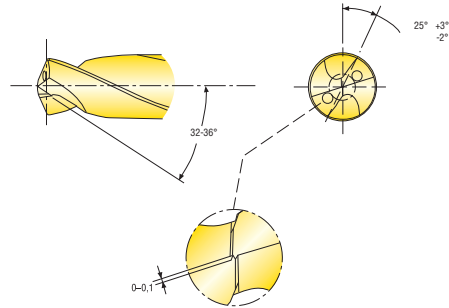

Drill Ø DC (mm)	L (mm)
2-10	0,1-0,3
10-20	0,2-0,4

3. Grinding of flat X

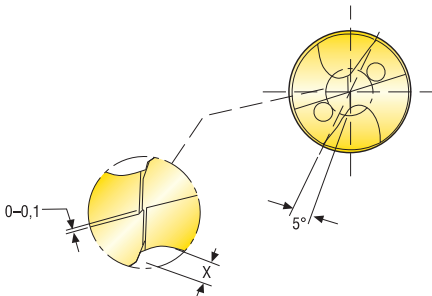

$X = 0,08 \times \text{drill diameter DC}$

4. Edge preparation

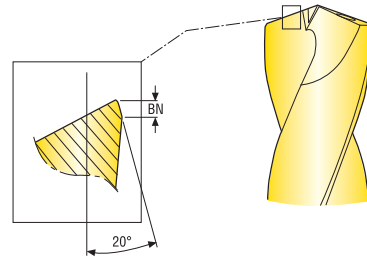

Workpiece material	BN (mm)	
	Drill Ø ≤10 (mm)	Drill Ø >10 (mm)
Steel	0,05	0,10
Stainless steel	0,05	0,05
Cast iron	0,05	0,10

Max. allowed flank wear before regrinding is 0,1–0,3 mm measured at the largest point.

Specifications

Proposed specification of diamond wheels:

- Conical clearance: Wheel shape 12A2 Grit size D54 (picture 1).
- Gashing: Wheel shape 1A1 or 1V1 Grit size D64-D46 (picture 2-3).
- Corner chamfer: Wheel shape 1A1 or 12A2 (picture 1).
- Edge treatment: grinding K-land or brushing (picture 4).

Important:

- The cutting edges must be uniform and have the same size of edge preparation.
- The edge preparation must be applied on the whole length of the cutting edges.

Regrinding instructions for SD203A, SD205A and SD207A

1. Conical flank

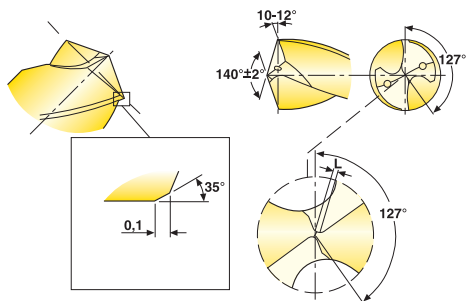

Lip height distance (axial run-out) to be within 0,02 mm

2. Web thinning

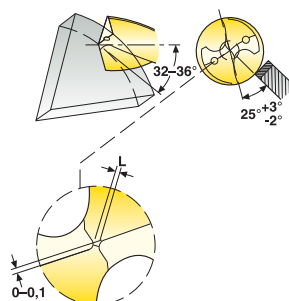

Drill Ø DC (mm)	L (mm)
2-10	0,1-0,3
10-20	0,2-0,4

3. Grinding of flat X

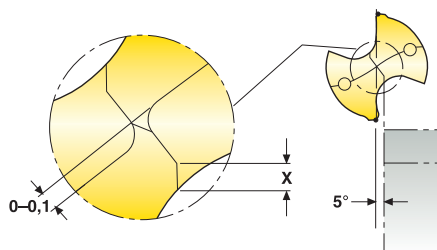

$X = 0,08 \times \text{drill diameter DC}$

4. Edge preparation

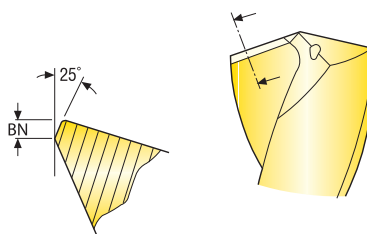

Workpiece material	BN (mm)	
	Drill Ø ≤10 (mm)	Drill Ø >10 (mm)
Steel	0,05	0,10
Stainless steel	0,05	0,05
Cast iron	0,05	0,10

Max. allowed flank wear before regrinding is 0,1–0,3 mm measured at the largest point.

Specifications

Proposed specification of diamond wheels:

Conical clearance: Wheel shape 12A2 Grit size D54 (picture 1).

Gashing: Wheel shape 1A1 or 1V1 Grit size D64-D46 (picture 2-3).

Corner chamfer: Wheel shape 1A1 or 12A2 (picture 1).

Edge treatment: grinding K-land or brushing (picture 4).

Important:

- The cutting edges must be uniform and have the same size of edge preparation.
- The edge preparation must be applied on the whole length of the cutting edges.

Regrinding instructions for chamfer drills

The regrinding instructions are the same as for SD203, SD203A, SD205A and SD207A except for the chamfer.

1. Chamfer relief

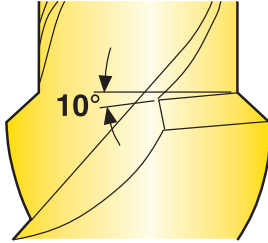

2. Edge preparation, chamfer

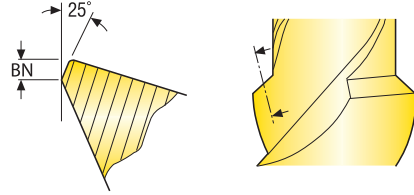

Workpiece material	BN (mm)	
	Drill $\varnothing \leq 10$ (mm)	Drill $\varnothing > 10$ (mm)
Steel	0,05	0,05
Stainless steel	0,05	0,05
Cast iron	0,05	0,05

Regrinding instructions for SD212A, SD216A, SD220A, SD225A and SD230A geometry

1. Conical flank

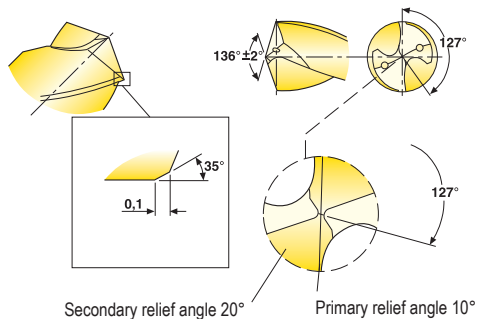

Lip height distance (axial run-out) to be within 0,02 mm

2. Web thinning

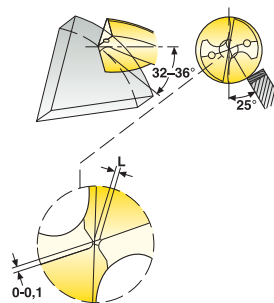

Drill Ø DC (mm)	L (mm)
2-10	0,2
10-20	0,4

3. Grinding of flat X

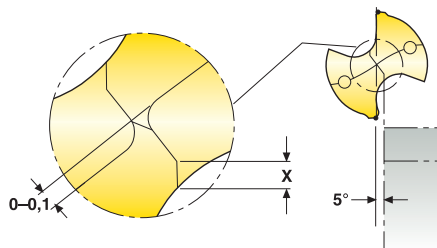

$X = 0,08 \times \text{drill diameter DC}$

4. Edge preparation

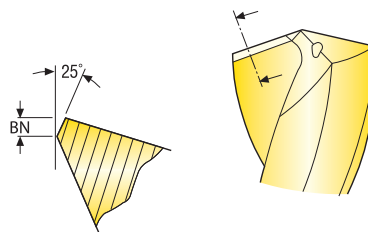

Workpiece material	BN (mm)	
	Drill Ø ≤10 (mm)	Drill Ø >10 (mm)
Steel	0,05	0,1
Stainless steel	0,05	0,05
Cast iron	0,05	0,1

Max. allowed flank wear before regrinding is 0,1–0,3 mm measured at the largest point.

Specifications

Proposed specification of diamond wheels:

Point relief: wheel shape 11V9 grit size D54 (picture 1).

Gashing: Wheel shape 1A1 or 1V1 Grit size D64-D46 (picture 2-3).

Corner chamfer: Wheel shape 1A1 or 12A2 (picture 1).

Edge treatment: grinding K-land or brushing (picture 4).

Important:

- The cutting edges must be uniform and have the same size of edge preparation.
- The edge preparation must be applied on the whole length of the cutting edges.

Regrinding instructions for SD265A

1. Conical flank

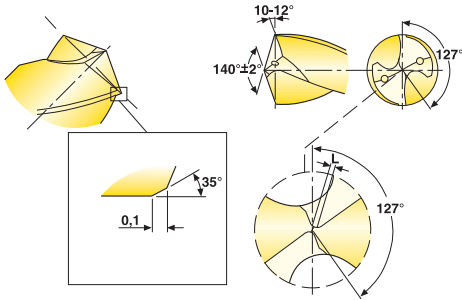

Lip height distance (axial run-out) to be within 0,02 mm

2. Web thinning

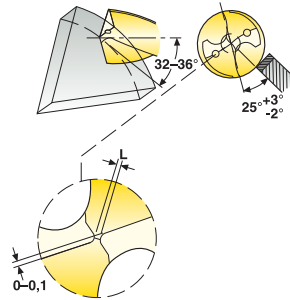

Drill \varnothing DC (mm)	L (mm)
2-10	0,1-0,3
10-20	0,2-0,4

3. Grinding of flat X

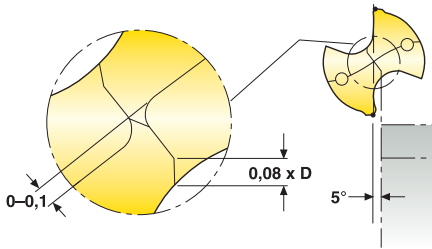

4. Edge preparation

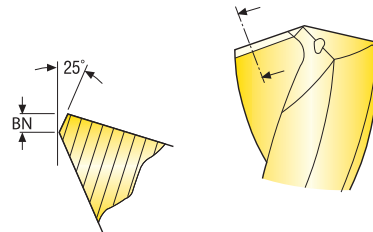

Workpiece material	Drill \varnothing \leq 10 (mm)	Drill \varnothing $>$ 10 (mm)
Steel	0,05	0,10
Stainless steel	0,05	0,05
Cast iron	0,05	0,10

Max. allowed flank wear before regrinding is 0,1–0,3 mm measured at the largest point.

Specifications

Proposed specification of diamond wheels:

Conical clearance: Wheel shape 12A2 Grit size D54 (picture 1).

Gashing: Wheel shape 1A1 or 1V1 Grit size D64-D46 (picture 2-3).

Corner chamfer: Wheel shape 1A1 or 12A2 (picture 1).

Edge treatment: grinding K-land or brushing (picture 4).

Important:

- The cutting edges must be uniform and have the same size of edge preparation.
- The edge preparation must be applied on the whole length of the cutting edges.

Regrinding instructions for -M and -T geometry

1. Conical flank

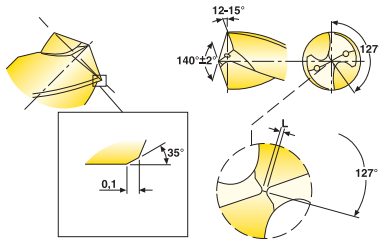

Lip height distance (axial run-out) to be within 0,01 mm

2. Web thinning

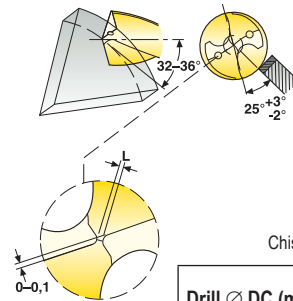

Chisel edge length L

Drill Ø DC (mm)	L (mm)
3-6	0,1-0,2
6-10	0,13-0,27
10-20	0,2-0,4

3. Grinding of flat X

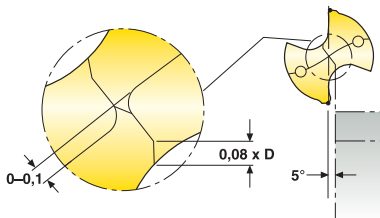

4. Edge preparation

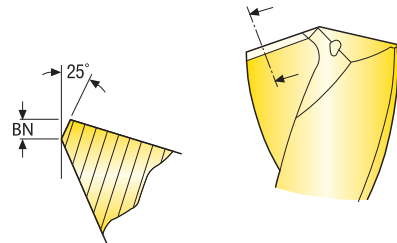

BN = 0,02

Max. allowed flank wear before regrinding is 0,1–0,3 mm measured at the largest point.

Specifications

Proposed specification of diamond wheels:

Conical clearance: Wheel shape 12A2 Grit size D54 (picture 1).

Gashing: Wheel shape 1A1 or 1V1 Grit size D64-D46 (picture 2-3).

Corner chamfer: Wheel shape 1A1 or 12A2 (picture 1).

Edge treatment: grinding K-land or brushing (picture 4).

Important:

- The cutting edges must be uniform and have the same size of edge preparation.
- The edge preparation must be applied on the whole length of the cutting edges.

Regrinding instructions for -N geometry

1. Conical flank

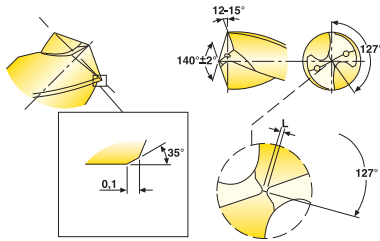

Lip height distance (axial run-out) to be within 0,01 mm

2. Web thinning

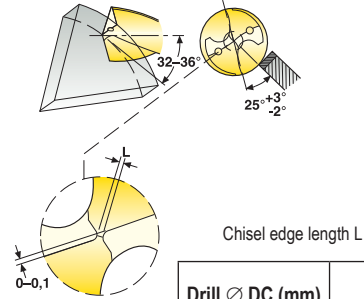

Chisel edge length L

Drill Ø DC (mm)	L (mm)
3-6	0,1-0,2
6-10	0,13-0,27
10-20	0,2-0,4

3. Grinding of flat X

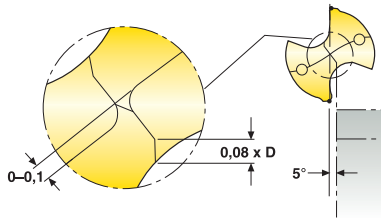

Max. allowed flank wear before regrinding is 0,1–0,3 mm measured at the largest point.

General:

X = 0,08 x drill diameter DC

Specifications

Proposed specification of diamond wheels:

Conical clearance: Wheel shape 12A2 Grit size D54 (picture 1).

Gashing: Wheel shape 1A1 or 1V1 Grit size D64-D46 (picture 2-3).

Corner chamfer: Wheel shape 1A1 or 12A2 (picture 1).

Edge treatment: grinding K-land or brushing (picture 4).

Important:

- The cutting edges must be uniform and have the same size of edge preparation.
- The edge preparation must be applied on the whole length of the cutting edges.

4. Edge preparation

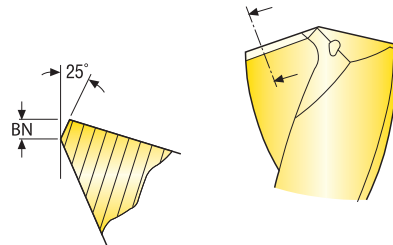

BN = 0,01-0,02

Cutting data – SD1103 – Ø3-20

SMG	f										v _c
	Ø3,00	Ø4,00	Ø6,00	Ø8,00	Ø10,00	Ø12,00	Ø14,00	Ø16,00	Ø18,00	Ø20,00	
P1	0.12	0.14	0.18	0.22	0.26	0.28	0.30	0.32	0.34	0.36	105
P2	0.12	0.14	0.18	0.22	0.26	0.28	0.32	0.34	0.36	0.36	105
P3	0.11	0.13	0.17	0.20	0.24	0.28	0.30	0.32	0.34	0.34	90
P4	0.11	0.13	0.17	0.20	0.24	0.26	0.28	0.30	0.32	0.34	80
P5	0.11	0.13	0.16	0.20	0.24	0.26	0.28	0.30	0.32	0.34	75
P6	0.11	0.12	0.16	0.20	0.24	0.26	0.28	0.30	0.32	0.34	85
P7	0.11	0.12	0.16	0.20	0.24	0.26	0.28	0.30	0.32	0.34	80
P8	0.11	0.13	0.17	0.20	0.24	0.28	0.30	0.32	0.34	0.34	75
P11	0.11	0.12	0.16	0.20	0.24	0.26	0.28	0.30	0.32	0.34	75
P12	0.075	0.085	0.11	0.14	0.16	0.18	0.19	0.20	0.22	0.22	46
M1	0.080	0.095	0.13	0.17	0.20	0.22	0.24	0.26	0.28	0.30	55
M2	0.070	0.085	0.12	0.15	0.18	0.20	0.22	0.24	0.26	0.26	45
K1	0.12	0.14	0.18	0.22	0.26	0.28	0.30	0.34	0.34	0.36	70
K2	0.11	0.13	0.16	0.20	0.24	0.26	0.28	0.30	0.32	0.34	60
K3	0.11	0.13	0.16	0.20	0.24	0.26	0.28	0.30	0.32	0.34	50
K4	0.11	0.13	0.16	0.20	0.24	0.26	0.28	0.30	0.32	0.34	49
K5	0.10	0.11	0.15	0.18	0.20	0.24	0.26	0.28	0.28	0.30	29
H3	0.048	0.055	0.075	0.090	0.10	0.12	0.13	0.14	0.14	0.15	24
H5	0.075	0.085	0.11	0.14	0.16	0.18	0.19	0.20	0.22	0.22	45
H7	0.048	0.055	0.075	0.090	0.10	0.12	0.13	0.14	0.14	0.15	24
H8	0.055	0.065	0.085	0.10	0.12	0.14	0.15	0.16	0.17	0.17	45
H11	0.075	0.085	0.11	0.14	0.16	0.18	0.19	0.20	0.22	0.22	60
H12	0.055	0.065	0.085	0.10	0.12	0.14	0.15	0.16	0.17	0.17	27

Cutting data – SD1103A & SD1105A – Ø3-20

SMG	f										v _c
	Ø3,00	Ø4,00	Ø6,00	Ø8,00	Ø10,00	Ø12,00	Ø14,00	Ø16,00	Ø18,00	Ø20,00	
P1	0.12	0.14	0.18	0.22	0.26	0.28	0.30	0.32	0.34	0.36	140
P2	0.12	0.14	0.18	0.22	0.26	0.28	0.32	0.34	0.36	0.36	140
P3	0.11	0.13	0.17	0.20	0.24	0.28	0.30	0.32	0.34	0.34	120
P4	0.11	0.13	0.17	0.20	0.24	0.26	0.28	0.30	0.32	0.34	105
P5	0.11	0.13	0.16	0.20	0.24	0.26	0.28	0.30	0.32	0.34	100
P6	0.11	0.12	0.16	0.20	0.24	0.26	0.28	0.30	0.32	0.34	110
P7	0.11	0.12	0.16	0.20	0.24	0.26	0.28	0.30	0.32	0.34	105
P8	0.11	0.13	0.17	0.20	0.24	0.28	0.30	0.32	0.34	0.34	100
P11	0.11	0.12	0.16	0.20	0.24	0.26	0.28	0.30	0.32	0.34	105
P12	0.075	0.085	0.11	0.14	0.16	0.18	0.19	0.20	0.22	0.22	60
M1	0.080	0.095	0.13	0.17	0.20	0.22	0.24	0.26	0.28	0.30	75
M2	0.070	0.085	0.12	0.15	0.18	0.20	0.22	0.24	0.26	0.26	60
M3	0.055	0.070	0.095	0.12	0.14	0.16	0.18	0.19	0.20	0.22	46
M4	0.050	0.060	0.085	0.11	0.12	0.14	0.15	0.17	0.18	0.19	34
M5	0.050	0.060	0.085	0.11	0.12	0.14	0.15	0.17	0.18	0.19	29
K1	0.12	0.14	0.18	0.22	0.26	0.28	0.30	0.34	0.34	0.36	90
K2	0.11	0.13	0.16	0.20	0.24	0.26	0.28	0.30	0.32	0.34	80
K3	0.11	0.13	0.16	0.20	0.24	0.26	0.28	0.30	0.32	0.34	65
K4	0.11	0.13	0.16	0.20	0.24	0.26	0.28	0.30	0.32	0.34	65
K5	0.10	0.11	0.15	0.18	0.20	0.24	0.26	0.28	0.28	0.30	37
N1	0.15	0.17	0.22	0.26	0.28	0.32	0.34	0.36	0.38	0.40	250
N2	0.15	0.17	0.22	0.26	0.28	0.32	0.34	0.36	0.38	0.40	160
N3	0.15	0.17	0.22	0.26	0.28	0.32	0.34	0.36	0.38	0.40	105
N11	0.15	0.17	0.22	0.26	0.28	0.32	0.34	0.36	0.38	0.40	200
H3	0.048	0.055	0.075	0.090	0.10	0.12	0.13	0.14	0.14	0.15	33
H5	0.075	0.085	0.11	0.14	0.16	0.18	0.19	0.20	0.22	0.22	60
H7	0.048	0.055	0.075	0.090	0.10	0.12	0.13	0.14	0.14	0.15	33
H8	0.055	0.065	0.085	0.10	0.12	0.14	0.15	0.16	0.17	0.17	60
H11	0.075	0.085	0.11	0.14	0.16	0.18	0.19	0.20	0.22	0.22	75
H12	0.055	0.065	0.085	0.10	0.12	0.14	0.15	0.16	0.17	0.17	36

SMG = Seco material group
 f = mm/rev
 v_c = m/min
 All cutting data are start values

Cutting data – SD203A-P – Ø2-8 – Metric

SMG		f						v _c
		Ø2,00	Ø3,00	Ø4,00	Ø5,00	Ø6,00	Ø8,00	
P1	P	0,14	0,17	0,20	0,24	0,26	0,32	185
P2	P	0,14	0,17	0,20	0,24	0,26	0,32	180
P3	P	0,14	0,16	0,19	0,22	0,25	0,32	155
P4	P	0,10	0,13	0,15	0,17	0,19	0,24	210
P5	P	0,10	0,12	0,14	0,17	0,19	0,22	205
P6	P	0,10	0,12	0,14	0,16	0,19	0,22	230
P7	P	0,10	0,12	0,14	0,16	0,19	0,22	215
P8	P	0,11	0,13	0,15	0,17	0,19	0,24	200
P11	P	0,10	0,12	0,14	0,16	0,19	0,22	210
P12	P	0,085	0,10	0,12	0,13	0,15	0,18	130
M1	M	0,075	0,095	0,11	0,13	0,15	0,19	110
M2	M	0,065	0,085	0,10	0,12	0,14	0,17	90
M3	M	0,055	0,065	0,080	0,095	0,11	0,14	70
M4	M	0,048	0,060	0,070	0,085	0,095	0,12	50
M5	M	0,048	0,060	0,070	0,085	0,095	0,12	42
K1	P	0,15	0,18	0,22	0,25	0,28	0,36	175
K2	P	0,14	0,17	0,20	0,22	0,26	0,32	150
K3	P	0,14	0,17	0,20	0,22	0,26	0,32	125
K4	P	0,14	0,17	0,20	0,22	0,26	0,32	120
K5	P	0,12	0,15	0,18	0,20	0,24	0,28	70
N1	N	0,13	0,16	0,19	0,22	0,26	0,32	350
N2	M	0,13	0,16	0,19	0,22	0,26	0,32	225
N3	M	0,13	0,16	0,19	0,22	0,26	0,32	150
N11	M	0,13	0,16	0,19	0,22	0,26	0,32	285
S1	M	0,040	0,048	0,055	0,065	0,075	0,095	39
S2	M	0,040	0,048	0,055	0,065	0,075	0,095	28
S3	M	0,040	0,048	0,055	0,065	0,075	0,095	28
S11	M	0,070	0,085	0,095	0,11	0,12	0,14	70
S12	M	0,070	0,085	0,095	0,11	0,12	0,14	55
S13	M	0,065	0,075	0,085	0,095	0,10	0,12	43
H3	P	0,055	0,070	0,080	0,090	0,10	0,12	30
H5	P	0,085	0,10	0,12	0,13	0,15	0,18	55
H7	P	0,055	0,070	0,080	0,090	0,10	0,12	30
H8	P	0,065	0,080	0,090	0,10	0,12	0,14	55
H11	P	0,085	0,10	0,12	0,13	0,15	0,18	70
H12	P	0,065	0,080	0,090	0,10	0,12	0,14	80
H21	P	0,065	0,080	0,090	0,10	0,12	0,14	55

SMG = Seco material group

f = mm/rev

v_c = m/min

All cutting data are start values

Cutting data – SD203A-P – Ø10-20 – Metric

SMG		f						v _c
		Ø10,00	Ø12,00	Ø14,00	Ø16,00	Ø18,00	Ø20,00	
P1	P	0,38	0,44	0,48	0,50	0,55	0,55	185
P2	P	0,38	0,44	0,48	0,50	0,55	0,60	180
P3	P	0,36	0,42	0,46	0,50	0,50	0,55	155
P4	P	0,28	0,30	0,34	0,36	0,38	0,40	210
P5	P	0,26	0,30	0,32	0,34	0,36	0,38	205
P6	P	0,26	0,30	0,32	0,34	0,36	0,38	230
P7	P	0,26	0,30	0,32	0,34	0,36	0,38	215
P8	P	0,28	0,32	0,34	0,36	0,38	0,40	200
P11	P	0,26	0,30	0,32	0,34	0,36	0,38	210
M1	M	0,22	0,25	0,28	0,30	0,30	0,32	110
M2	M	0,20	0,22	0,25	0,26	0,28	0,30	90
M3	M	0,16	0,18	0,20	0,22	0,22	0,24	70
M4	M	0,14	0,16	0,17	0,19	0,20	0,20	50
M5	M	0,14	0,16	0,17	0,19	0,20	0,20	42
K1	P	0,42	0,48	0,50	0,55	0,60	0,65	175
K2	P	0,38	0,42	0,48	0,50	0,55	0,55	150
K3	P	0,38	0,42	0,48	0,50	0,55	0,55	125
K4	P	0,38	0,42	0,48	0,50	0,55	0,55	120
K5	P	0,34	0,38	0,42	0,46	0,48	0,50	70
N1	N	0,38	0,42	0,46	0,50	0,55	0,55	350
N2	M	0,38	0,42	0,46	0,50	0,55	0,55	225
N3	M	0,38	0,42	0,46	0,50	0,55	0,55	150
N11	M	0,38	0,42	0,46	0,50	0,55	0,55	285
S1	M	0,11	0,13	0,15	0,16	0,17	0,19	39
S2	M	0,11	0,13	0,15	0,16	0,17	0,19	28
S3	M	0,11	0,13	0,15	0,16	0,17	0,19	28
S11	M	0,17	0,19	0,22	0,24	0,25	0,26	70
S12	M	0,17	0,19	0,22	0,24	0,25	0,26	55
S13	M	0,15	0,17	0,19	0,20	0,22	0,22	43
H3	P	0,14	0,16	0,18	0,19	0,20	0,20	30
H5	P	0,22	0,24	0,26	0,28	0,30	0,32	55
H7	P	0,14	0,16	0,18	0,19	0,20	0,20	30
H8	P	0,16	0,19	0,20	0,22	0,24	0,24	55
H11	P	0,22	0,24	0,26	0,28	0,30	0,32	70
H12	P	0,16	0,19	0,20	0,22	0,24	0,24	80
H21	P	0,16	0,19	0,20	0,22	0,24	0,24	55

SMG = Seco material group
 f = mm/rev
 v_c = m/min
 All cutting data are start values

Cutting data – SD205A-P – Ø2-8 – Metric

SMG		f						v _c
		Ø2,00	Ø3,00	Ø4,00	Ø5,00	Ø6,00	Ø8,00	
P1	P	0,14	0,17	0,20	0,24	0,26	0,32	170
P2	P	0,14	0,17	0,20	0,24	0,26	0,32	165
P3	P	0,14	0,16	0,19	0,22	0,25	0,32	140
P4	P	0,10	0,13	0,15	0,17	0,19	0,24	195
P5	P	0,10	0,12	0,14	0,17	0,19	0,22	185
P6	P	0,10	0,12	0,14	0,16	0,19	0,22	210
P7	P	0,10	0,12	0,14	0,16	0,19	0,22	200
P8	P	0,11	0,13	0,15	0,17	0,19	0,24	185
P11	P	0,10	0,12	0,14	0,16	0,19	0,22	195
M1	M	0,075	0,095	0,11	0,13	0,15	0,19	100
M2	M	0,065	0,085	0,10	0,12	0,14	0,17	80
M3	M	0,055	0,065	0,080	0,095	0,11	0,14	60
M4	M	0,048	0,060	0,070	0,085	0,095	0,12	46
M5	M	0,048	0,060	0,070	0,085	0,095	0,12	38
K1	P	0,15	0,18	0,22	0,25	0,28	0,36	160
K2	P	0,14	0,17	0,20	0,22	0,26	0,32	135
K3	P	0,14	0,17	0,20	0,22	0,26	0,32	115
K4	P	0,14	0,17	0,20	0,22	0,26	0,32	110
K5	P	0,12	0,15	0,18	0,20	0,24	0,28	65
N1	N	0,13	0,16	0,19	0,22	0,26	0,32	350
N2	M	0,13	0,16	0,19	0,22	0,26	0,32	200
N3	M	0,13	0,16	0,19	0,22	0,26	0,32	135
N11	M	0,13	0,16	0,19	0,22	0,26	0,32	255
S1	M	0,040	0,048	0,055	0,065	0,075	0,095	35
S2	M	0,040	0,048	0,055	0,065	0,075	0,095	25
S3	M	0,040	0,048	0,055	0,065	0,075	0,095	25
S11	M	0,070	0,085	0,095	0,11	0,12	0,14	65
S12	M	0,070	0,085	0,095	0,11	0,12	0,14	50
S13	M	0,065	0,075	0,085	0,095	0,10	0,12	39
H3	P	0,055	0,070	0,080	0,090	0,10	0,12	27
H5	P	0,085	0,10	0,12	0,13	0,15	0,18	50
H7	P	0,055	0,070	0,080	0,090	0,10	0,12	27
H8	P	0,065	0,080	0,090	0,10	0,12	0,14	50
H11	P	0,085	0,10	0,12	0,13	0,15	0,18	65
H12	P	0,065	0,080	0,090	0,10	0,12	0,14	70
H21	P	0,065	0,080	0,090	0,10	0,12	0,14	50

SMG = Seco material group

f = mm/rev

v_c = m/min

All cutting data are start values

Cutting data – SD205A-P – Ø10-20 – Metric

SMG		f						v _c
		Ø10,00	Ø12,00	Ø14,00	Ø16,00	Ø18,00	Ø20,00	
P1	P	0,38	0,44	0,48	0,50	0,55	0,55	170
P2	P	0,38	0,44	0,48	0,50	0,55	0,60	165
P3	P	0,36	0,42	0,46	0,50	0,50	0,55	140
P4	P	0,28	0,30	0,34	0,36	0,38	0,40	195
P5	P	0,26	0,30	0,32	0,34	0,36	0,38	185
P6	P	0,26	0,30	0,32	0,34	0,36	0,38	210
P7	P	0,26	0,30	0,32	0,34	0,36	0,38	200
P8	P	0,28	0,32	0,34	0,36	0,38	0,40	185
P11	P	0,26	0,30	0,32	0,34	0,36	0,38	195
M1	M	0,22	0,25	0,28	0,30	0,30	0,32	100
M2	M	0,20	0,22	0,25	0,26	0,28	0,30	80
M3	M	0,16	0,18	0,20	0,22	0,22	0,24	60
M4	M	0,14	0,16	0,17	0,19	0,20	0,20	46
M5	M	0,14	0,16	0,17	0,19	0,20	0,20	38
K1	P	0,42	0,48	0,50	0,55	0,60	0,65	160
K2	P	0,38	0,42	0,48	0,50	0,55	0,55	135
K3	P	0,38	0,42	0,48	0,50	0,55	0,55	115
K4	P	0,38	0,42	0,48	0,50	0,55	0,55	110
K5	P	0,34	0,38	0,42	0,46	0,48	0,50	65
N1	N	0,38	0,42	0,46	0,50	0,55	0,55	350
N2	M	0,38	0,42	0,46	0,50	0,55	0,55	200
N3	M	0,38	0,42	0,46	0,50	0,55	0,55	135
N11	M	0,38	0,42	0,46	0,50	0,55	0,55	255
S1	M	0,11	0,13	0,15	0,16	0,17	0,19	35
S2	M	0,11	0,13	0,15	0,16	0,17	0,19	25
S3	M	0,11	0,13	0,15	0,16	0,17	0,19	25
S11	M	0,17	0,19	0,22	0,24	0,25	0,26	65
S12	M	0,17	0,19	0,22	0,24	0,25	0,26	50
S13	M	0,15	0,17	0,19	0,20	0,22	0,22	39
H3	P	0,14	0,16	0,18	0,19	0,20	0,20	27
H5	P	0,22	0,24	0,26	0,28	0,30	0,32	50
H7	P	0,14	0,16	0,18	0,19	0,20	0,20	27
H8	P	0,16	0,19	0,20	0,22	0,24	0,24	50
H11	P	0,22	0,24	0,26	0,28	0,30	0,32	65
H12	P	0,16	0,19	0,20	0,22	0,24	0,24	70
H21	P	0,16	0,19	0,20	0,22	0,24	0,24	50

SMG = Seco material group
 f = mm/rev
 v_c = m/min
 All cutting data are start values

Cutting data – SD207A-P – Ø3-20 – Metric

SMG		f										v _c
		Ø3,00	Ø5,00	Ø6,00	Ø8,00	Ø10,00	Ø12,00	Ø14,00	Ø16,00	Ø18,00	Ø20,00	
P1	P	0.17	0.24	0.26	0.32	0.38	0.44	0.48	0.50	0.55	0.55	155
P2	P	0.17	0.24	0.26	0.32	0.38	0.44	0.48	0.50	0.55	0.60	155
P3	P	0.16	0.22	0.25	0.32	0.36	0.42	0.46	0.50	0.50	0.55	130
P4	P	0.13	0.17	0.19	0.24	0.28	0.30	0.34	0.36	0.38	0.40	180
P5	P	0.12	0.17	0.19	0.22	0.26	0.30	0.32	0.34	0.36	0.38	175
P6	P	0.12	0.16	0.19	0.22	0.26	0.30	0.32	0.34	0.36	0.38	195
P7	P	0.12	0.16	0.19	0.22	0.26	0.30	0.32	0.34	0.36	0.38	185
P8	P	0.13	0.17	0.19	0.24	0.28	0.32	0.34	0.36	0.38	0.40	175
P11	P	0.12	0.16	0.19	0.22	0.26	0.30	0.32	0.34	0.36	0.38	180
M1	P	0.095	0.13	0.15	0.19	0.22	0.25	0.28	0.30	0.30	0.32	50
M2	P	0.085	0.12	0.14	0.17	0.20	0.22	0.25	0.26	0.28	0.30	41
M3	P	0.065	0.095	0.11	0.14	0.16	0.18	0.20	0.22	0.22	0.24	31
M4	P	0.060	0.085	0.095	0.12	0.14	0.16	0.17	0.19	0.20	0.20	24
M5	P	0.060	0.085	0.095	0.12	0.14	0.16	0.17	0.19	0.20	0.20	20
K1	P	0.18	0.25	0.28	0.36	0.42	0.48	0.50	0.55	0.60	0.65	150
K2	P	0.17	0.22	0.26	0.32	0.38	0.42	0.48	0.50	0.55	0.55	130
K3	P	0.17	0.22	0.26	0.32	0.38	0.42	0.48	0.50	0.55	0.55	110
K4	P	0.17	0.22	0.26	0.32	0.38	0.42	0.48	0.50	0.55	0.55	105
K5	P	0.15	0.20	0.24	0.28	0.34	0.38	0.42	0.46	0.48	0.50	60
H3	P	0.070	0.090	0.10	0.12	0.14	0.16	0.18	0.19	0.20	0.20	26
H5	P	0.10	0.13	0.15	0.18	0.22	0.24	0.26	0.28	0.30	0.32	47
H7	P	0.070	0.090	0.10	0.12	0.14	0.16	0.18	0.19	0.20	0.20	26
H8	P	0.080	0.10	0.12	0.14	0.16	0.19	0.20	0.22	0.24	0.24	47
H11	P	0.10	0.13	0.15	0.18	0.22	0.24	0.26	0.28	0.30	0.32	60
H12	P	0.080	0.10	0.12	0.14	0.16	0.19	0.20	0.22	0.24	0.24	65
H21	P	0.080	0.10	0.12	0.14	0.16	0.19	0.20	0.22	0.24	0.24	47

SMG = Seco material group

f = mm/rev

v_c = m/min

All cutting data are start values

Cutting data – SD206 – Ø0,7-2

SMG		f			v _c
		Ø0,70	Ø1,00	Ø2,00	
P1	P	0,080	0,090	0,11	140
P2	P	0,085	0,090	0,12	140
P3	P	0,080	0,085	0,11	120
P4	P	0,080	0,085	0,11	105
P5	P	0,075	0,085	0,11	100
P6	P	0,075	0,080	0,10	110
P7	P	0,075	0,080	0,10	105
P8	P	0,080	0,085	0,11	100
P11	P	0,075	0,080	0,10	105
P12	P	0,050	0,055	0,070	60
K1	P	0,085	0,090	0,12	100
K2	P	0,075	0,085	0,11	85
K3	P	0,075	0,085	0,11	75
K4	P	0,075	0,085	0,11	70
K5	P	0,070	0,075	0,095	42

Cutting data – SD206A – Ø1-2

SMG		f			v _c
		Ø1,00	Ø1,50	Ø2,00	
P1	P	0,090	0,10	0,11	175
P2	P	0,090	0,10	0,12	170
P3	P	0,085	0,10	0,11	145
P4	P	0,085	0,095	0,11	130
P5	P	0,085	0,095	0,11	125
P6	P	0,080	0,095	0,10	140
P7	P	0,080	0,095	0,10	130
P8	P	0,085	0,10	0,11	125
P11	P	0,080	0,095	0,10	125
P12	P	0,055	0,065	0,070	75
M1	P	0,055	0,065	0,075	95
M2	P	0,050	0,060	0,070	75
M3	P	0,042	0,048	0,055	60
M4	P	0,036	0,042	0,048	43
M5	P	0,036	0,042	0,048	36
K1	P	0,095	0,11	0,12	115
K2	P	0,085	0,10	0,11	100
K3	P	0,085	0,10	0,11	85
K4	P	0,085	0,10	0,11	80
K5	P	0,075	0,090	0,10	47
N2	P	0,10	0,12	0,13	190
N3	P	0,10	0,12	0,13	125

SMG = Seco material group

f = mm/rev

v_c = m/min

All cutting data are start values

Cutting data – SD216A – Ø3-14

SMG		f							v _c
		Ø3,00	Ø5,00	Ø6,00	Ø8,00	Ø10,00	Ø12,00	Ø14,00	
P1	P	0,13	0,18	0,20	0,26	0,30	0,32	0,36	125
P2	P	0,14	0,18	0,20	0,26	0,30	0,34	0,36	120
P3	P	0,13	0,17	0,20	0,24	0,28	0,32	0,34	105
P4	P	0,13	0,17	0,19	0,24	0,28	0,30	0,34	90
P5	P	0,12	0,17	0,19	0,24	0,28	0,30	0,34	85
P6	P	0,12	0,17	0,19	0,24	0,26	0,30	0,32	95
P7	P	0,12	0,17	0,19	0,24	0,26	0,30	0,32	90
P8	P	0,13	0,17	0,20	0,24	0,28	0,32	0,34	85
P11	P	0,12	0,17	0,19	0,24	0,26	0,30	0,32	90
P12	P	0,085	0,11	0,13	0,16	0,18	0,20	0,22	55
M1	P	0,095	0,13	0,15	0,19	0,22	0,26	0,28	65
M2	P	0,085	0,12	0,14	0,17	0,20	0,22	0,26	55
M3	P	0,070	0,095	0,11	0,14	0,16	0,18	0,20	41
M4	P	0,060	0,085	0,095	0,12	0,14	0,16	0,18	31
M5	P	0,060	0,085	0,095	0,12	0,14	0,16	0,18	25
K1	P	0,15	0,22	0,24	0,30	0,36	0,40	0,44	80
K2	P	0,14	0,19	0,22	0,28	0,32	0,36	0,40	70
K3	P	0,14	0,19	0,22	0,28	0,32	0,36	0,40	60
K4	P	0,14	0,19	0,22	0,28	0,32	0,36	0,40	55
K5	P	0,12	0,17	0,20	0,24	0,30	0,32	0,36	33
N2	P	0,16	0,22	0,26	0,32	0,38	0,42	0,46	135
N3	P	0,16	0,22	0,26	0,32	0,38	0,42	0,46	90
H3	P	0,055	0,075	0,085	0,10	0,12	0,14	0,15	22
H5	P	0,085	0,11	0,13	0,16	0,18	0,20	0,22	40
H7	P	0,055	0,075	0,085	0,10	0,12	0,14	0,15	22
H8	P	0,065	0,085	0,10	0,12	0,14	0,16	0,17	40
H11	P	0,085	0,11	0,13	0,16	0,18	0,20	0,22	50
H12	P	0,065	0,085	0,10	0,12	0,14	0,16	0,17	31
H21	P	0,065	0,085	0,10	0,12	0,14	0,16	0,17	40

SMG = Seco material group

f = mm/rev

v_c = m/min

All cutting data are start values

Cutting data – SD230A – Ø3-12

SMG		f						v _c
		Ø3,00	Ø5,00	Ø6,00	Ø8,00	Ø10,00	Ø12,00	
P1	P	0,13	0,18	0,20	0,26	0,30	0,32	90
P2	P	0,14	0,18	0,20	0,26	0,30	0,34	90
P3	P	0,13	0,17	0,20	0,24	0,28	0,32	75
P4	P	0,13	0,17	0,19	0,24	0,28	0,30	70
P5	P	0,12	0,17	0,19	0,24	0,28	0,30	65
P6	P	0,12	0,17	0,19	0,24	0,26	0,30	75
P7	P	0,12	0,17	0,19	0,24	0,26	0,30	70
P8	P	0,13	0,17	0,20	0,24	0,28	0,32	65
P11	P	0,12	0,17	0,19	0,24	0,26	0,30	65
P12	P	0,085	0,11	0,13	0,16	0,18	0,20	39
M1	P	0,095	0,13	0,15	0,19	0,22	0,26	50
M2	P	0,085	0,12	0,14	0,17	0,20	0,22	40
M3	P	0,070	0,095	0,11	0,14	0,16	0,18	30
M4	P	0,060	0,085	0,095	0,12	0,14	0,16	23
M5	P	0,060	0,085	0,095	0,12	0,14	0,16	19
K1	P	0,15	0,22	0,24	0,30	0,36	0,40	60
K2	P	0,14	0,19	0,22	0,28	0,32	0,36	50
K3	P	0,14	0,19	0,22	0,28	0,32	0,36	44
K4	P	0,14	0,19	0,22	0,28	0,32	0,36	42
K5	P	0,12	0,17	0,20	0,24	0,30	0,32	25
N2	P	0,16	0,22	0,26	0,32	0,38	0,42	100
N3	P	0,16	0,22	0,26	0,32	0,38	0,42	65
H3	P	0,055	0,075	0,085	0,10	0,12	0,14	16
H5	P	0,085	0,11	0,13	0,16	0,18	0,20	30
H7	P	0,055	0,075	0,085	0,10	0,12	0,14	16
H8	P	0,065	0,085	0,10	0,12	0,14	0,16	30
H11	P	0,085	0,11	0,13	0,16	0,18	0,20	39
H12	P	0,065	0,085	0,10	0,12	0,14	0,16	24
H21	P	0,065	0,085	0,10	0,12	0,14	0,16	30

Cutting data – SD245A – Ø4-16

SMG		f						v _c	
		Ø4,00	Ø6,00	Ø8,00	Ø10,00	Ø12,00	Ø14,00		Ø16,00
P1	P	0,11	0,15	0,19	0,22	0,26	0,28	0,32	185
P2	P	0,11	0,15	0,19	0,22	0,26	0,30	0,32	180
P3	P	0,11	0,14	0,18	0,22	0,24	0,28	0,30	155
P4	P	0,11	0,14	0,18	0,22	0,24	0,26	0,30	135
P5	P	0,10	0,14	0,17	0,20	0,24	0,26	0,28	130
P6	P	0,10	0,14	0,17	0,20	0,24	0,26	0,28	145
P7	P	0,10	0,14	0,17	0,20	0,24	0,26	0,28	140
P8	P	0,11	0,14	0,18	0,22	0,24	0,28	0,30	130
P11	P	0,10	0,14	0,17	0,20	0,24	0,26	0,28	135
P12	P	0,070	0,095	0,12	0,14	0,16	0,18	0,20	80
M1	P	0,11	0,15	0,19	0,22	0,26	0,30	0,32	100
M2	P	0,10	0,14	0,17	0,20	0,24	0,26	0,28	80
K1	P	0,11	0,15	0,19	0,22	0,26	0,30	0,32	120
K2	P	0,10	0,14	0,17	0,20	0,24	0,26	0,28	105
K3	P	0,10	0,14	0,17	0,20	0,24	0,26	0,28	90
K4	P	0,10	0,14	0,17	0,20	0,24	0,26	0,28	85
K5	P	0,095	0,12	0,16	0,19	0,22	0,24	0,26	50
N2	P	0,14	0,19	0,24	0,28	0,34	0,38	0,40	200
N3	P	0,14	0,19	0,24	0,28	0,34	0,38	0,40	135
N11	P	0,14	0,19	0,24	0,28	0,34	0,38	0,40	255

SMG = Seco material group
 f = mm/rev
 v_c = m/min
 All cutting data are start values

Cutting data – SD265A – Ø4-16

SMG		f							v _c
		Ø4,00	Ø6,00	Ø8,00	Ø10,00	Ø12,00	Ø14,00	Ø16,00	
P1	P	0,12	0,16	0,20	0,24	0,28	0,30	0,34	180
P2	P	0,12	0,16	0,20	0,24	0,28	0,30	0,34	175
P3	P	0,11	0,15	0,19	0,22	0,26	0,30	0,32	150
P4	P	0,11	0,15	0,19	0,22	0,26	0,28	0,32	135
P5	P	0,11	0,15	0,18	0,22	0,26	0,28	0,30	130
P6	P	0,11	0,15	0,18	0,22	0,26	0,28	0,30	145
P7	P	0,11	0,15	0,18	0,22	0,26	0,28	0,30	135
P8	P	0,11	0,15	0,19	0,22	0,26	0,30	0,32	130
P11	P	0,11	0,15	0,18	0,22	0,26	0,28	0,30	130
P12	P	0,075	0,10	0,12	0,15	0,17	0,19	0,20	80
M1	P	0,12	0,16	0,20	0,24	0,28	0,30	0,34	100
M2	P	0,11	0,15	0,18	0,22	0,26	0,28	0,30	80
K1	P	0,12	0,16	0,20	0,24	0,28	0,30	0,34	120
K2	P	0,11	0,15	0,18	0,22	0,26	0,28	0,30	100
K3	P	0,11	0,15	0,18	0,22	0,26	0,28	0,30	85
K4	P	0,11	0,15	0,18	0,22	0,26	0,28	0,30	85
K5	P	0,10	0,13	0,17	0,20	0,22	0,26	0,28	49
N2	P	0,15	0,20	0,26	0,30	0,36	0,40	0,42	195
N3	P	0,15	0,20	0,26	0,30	0,36	0,40	0,42	130
N11	P	0,15	0,20	0,26	0,30	0,36	0,40	0,42	250

SMG = Seco material group

f = mm/rev

v_c = m/min

All cutting data are start values

Cutting data – SD205A-C1 – Ø3-13

SMG		f						v _c
		Ø3,00	Ø5,00	Ø7,00	Ø9,00	Ø11,00	Ø13,00	
TS2	C1	0,060	0,060	0,065	0,070	0,075	0,080	65
TS3	C1	0,060	0,060	0,065	0,070	0,075	0,080	50
TP2	C1	0,060	0,060	0,065	0,070	0,075	0,080	65
TP3	C1	0,060	0,060	0,065	0,070	0,075	0,080	50

Cutting data – SD205A-C2 – Ø3-13

SMG		f						v _c
		Ø3,00	Ø5,00	Ø7,00	Ø9,00	Ø11,00	Ø13,00	
N1	C2	0,095	0,10	0,11	0,12	0,13	0,14	80
N2	C2	0,095	0,10	0,11	0,12	0,13	0,14	50
N3	C2	0,095	0,10	0,11	0,12	0,13	0,14	33
S11	C2	0,055	0,065	0,080	0,090	0,10	0,11	50
S12	C2	0,055	0,065	0,080	0,090	0,10	0,11	40
S13	C2	0,048	0,060	0,070	0,080	0,090	0,10	31

Cutting data – SD203-CX1 – Ø3-9

SMG		f				v _c
		Ø3,00	Ø5,00	Ø7,00	Ø9,00	
TS2	CX1	0,075	0,085	0,090	0,10	150
TS3	CX1	0,075	0,085	0,090	0,10	120
TP2	CX1	0,075	0,085	0,090	0,10	150
TP3	CX1	0,075	0,085	0,090	0,10	120

Cutting data – SD203A-CX2 – Ø3-9

SMG		f				v _c
		Ø3,00	Ø5,00	Ø7,00	Ø9,00	
N1	CX2	0,048	0,050	0,055	0,060	185
N2	CX2	0,048	0,050	0,055	0,060	120
N3	CX2	0,048	0,050	0,055	0,060	80
S11	CX2	0,019	0,020	0,024	0,024	16
S12	CX2	0,019	0,020	0,024	0,024	12
S13	CX2	0,017	0,018	0,020	0,022	9

Cutting data – SD205-CX31 – Ø4-8

SMG		f					v _c
		Ø4,00	Ø5,00	Ø6,00	Ø7,00	Ø8,00	
N1	CX31	0,10	0,10	0,11	0,11	0,12	155
N2	CX31	0,10	0,10	0,11	0,11	0,12	100
N3	CX31	0,10	0,10	0,11	0,11	0,12	65
S11	CX31	0,040	0,048	0,055	0,065	0,070	16
S12	CX31	0,040	0,048	0,055	0,065	0,070	12
S13	CX31	0,034	0,042	0,048	0,055	0,065	9
TS2	CX31	0,080	0,085	0,090	0,090	0,095	125
TS3	CX31	0,080	0,085	0,090	0,090	0,095	100
TP2	CX31	0,080	0,085	0,090	0,090	0,095	125
TP3	CX31	0,080	0,085	0,090	0,090	0,095	100

SMG = Seco material group

f = mm/rev

v_c = m/min

All cutting data are start values

Cutting data depends on exiting material. N1-N3 and S11-S13 used for stack drilling application

N1-N3 = Alu

S11-S13 = Ti

TS/TP = Composite

Cutting data – SD22 & SD26 – Ø0,1-0,3

SMG	f			v _c
	Ø0,10	Ø0,20	Ø0,30	
P1	0,0011	0,0017	0,0024	11
P2	0,0011	0,0017	0,0024	11
P3	0,0010	0,0016	0,0022	10
P4	0,0010	0,0016	0,0022	8
P5	0,0010	0,0016	0,0022	8
P6	0,0010	0,0016	0,0022	9
P7	0,0010	0,0016	0,0022	8
P8	0,0010	0,0016	0,0022	8
P11	0,0010	0,0016	0,0022	8
P12	0,00070	0,0011	0,0015	5
M1	0,0011	0,0017	0,0024	2
M2	0,0010	0,0016	0,0022	2
K1	0,0011	0,0017	0,0024	6
K2	0,0010	0,0016	0,0022	5
K3	0,0010	0,0016	0,0022	4
K4	0,0010	0,0016	0,0022	4
K5	0,00090	0,0014	0,0019	3
N2	0,0014	0,0022	0,0030	15
N3	0,0014	0,0022	0,0030	10
S11	0,00080	0,0013	0,0017	4
S12	0,00080	0,0013	0,0017	3

Cutting data – SD22 & SD26 – Ø0,4-0,5

SMG	f		v _c
	Ø0,40	Ø0,50	
P1	0,0030	0,0036	14
P2	0,0030	0,0036	14
P3	0,0028	0,0034	12
P4	0,0028	0,0034	10
P5	0,0028	0,0034	10
P6	0,0028	0,0032	11
P7	0,0028	0,0032	11
P8	0,0028	0,0034	10
P11	0,0028	0,0032	10
P12	0,0019	0,0022	6
M1	0,0030	0,0036	5
M2	0,0028	0,0034	4
K1	0,0030	0,0036	10
K2	0,0028	0,0034	9
K3	0,0028	0,0034	7
K4	0,0028	0,0034	7
K5	0,0024	0,0030	4
N2	0,0038	0,0046	30
N3	0,0038	0,0046	20
S11	0,0022	0,0026	8
S12	0,0022	0,0026	6

SMG = Seco material group

f = mm/rev

v_c = m/min

All cutting data are start values

Cutting data – SD22 & SD26 – Ø0,6-0,8

SMG	f			v _c
	Ø0,60	Ø0,70	Ø0,80	
P1	0,0042	0,0048	0,0055	28
P2	0,0042	0,0050	0,0055	28
P3	0,0040	0,0046	0,0055	24
P4	0,0040	0,0046	0,0050	21
P5	0,0038	0,0044	0,0050	20
P6	0,0038	0,0044	0,0050	22
P7	0,0038	0,0044	0,0050	21
P8	0,0040	0,0046	0,0055	20
P11	0,0038	0,0044	0,0050	21
P12	0,0026	0,0030	0,0034	12
M1	0,0042	0,0050	0,0055	9
M2	0,0038	0,0044	0,0050	7
K1	0,0042	0,0050	0,0055	15
K2	0,0038	0,0044	0,0050	13
K3	0,0038	0,0044	0,0050	11
K4	0,0038	0,0044	0,0050	10
K5	0,0036	0,0040	0,0046	6
N2	0,0055	0,0065	0,0070	60
N3	0,0055	0,0065	0,0070	40
S11	0,0032	0,0036	0,0040	13
S12	0,0032	0,0036	0,0040	10

Cutting data – SD22 & SD26 – Ø0,9-1,1

SMG	f			v _c
	Ø0,90	Ø1,00	Ø1,10	
P1	0,0060	0,0065	0,0075	50
P2	0,0060	0,0070	0,0075	48
P3	0,0060	0,0065	0,0070	42
P4	0,0055	0,0065	0,0070	37
P5	0,0055	0,0060	0,0070	35
P6	0,0055	0,0060	0,0065	39
P7	0,0055	0,0060	0,0065	37
P8	0,0060	0,0065	0,0070	35
P11	0,0055	0,0060	0,0065	36
P12	0,0038	0,0042	0,0046	21
M1	0,0060	0,0070	0,0075	12
M2	0,0055	0,0060	0,0070	10
K1	0,0060	0,0070	0,0075	20
K2	0,0055	0,0060	0,0070	17
K3	0,0055	0,0060	0,0070	15
K4	0,0055	0,0060	0,0070	14
K5	0,0050	0,0055	0,0060	8
N2	0,0080	0,0085	0,0095	80
N3	0,0080	0,0085	0,0095	55
S11	0,0046	0,0050	0,0055	19
S12	0,0046	0,0050	0,0055	15

SMG = Seco material group
 f = mm/rev
 v_c = m/min
 All cutting data are start values

Cutting data – SD22 & SD26 – Ø1,2-2,0

SMG	f					v _c
	Ø1,20	Ø1,40	Ø1,60	Ø1,80	Ø2,00	
P1	0,0080	0,0090	0,010	0,012	0,013	70
P2	0,0080	0,0095	0,011	0,012	0,013	70
P3	0,0075	0,0090	0,010	0,011	0,012	60
P4	0,0075	0,0085	0,010	0,011	0,012	50
P5	0,0075	0,0085	0,0095	0,011	0,012	50
P6	0,0075	0,0085	0,0095	0,011	0,012	55
P7	0,0075	0,0085	0,0095	0,011	0,012	55
P8	0,0075	0,0090	0,010	0,011	0,012	50
P11	0,0075	0,0085	0,0095	0,011	0,012	50
P12	0,0050	0,0060	0,0065	0,0075	0,0080	30
M1	0,0080	0,0095	0,011	0,012	0,013	15
M2	0,0075	0,0085	0,0095	0,011	0,012	12
K1	0,0080	0,0095	0,011	0,012	0,013	35
K2	0,0075	0,0085	0,0095	0,011	0,012	30
K3	0,0075	0,0085	0,0095	0,011	0,012	26
K4	0,0075	0,0085	0,0095	0,011	0,012	25
K5	0,0065	0,0075	0,0085	0,010	0,011	15
N2	0,010	0,012	0,014	0,015	0,017	100
N3	0,010	0,012	0,014	0,015	0,017	65
S11	0,0060	0,0070	0,0075	0,0085	0,0095	26
S12	0,0060	0,0070	0,0075	0,0085	0,0095	20

SMG = Seco material group

f = mm/rev

v_c = m/min

All cutting data are start values



Range overview

Crownloc®	∅ Range	Drill depth	Crown tolerance	Hole tolerance (1)	Surface finish (2)
<p>SD101</p>  <p>Page(s) 110</p>	12,00–25,99 mm	~ 1,5 x D	k7	IT10	R _a 1–3 μm
<p>SD103</p>  <p>Page(s) 111</p>	10,00–25,99 mm	~ 3 x D	k7	IT10	R _a 1–3 μm
<p>SD105</p>  <p>Page(s) 112</p>	10,00–25,99 mm	~ 5 x D	k7	IT10	R _a 1–3 μm
<p>SD107</p>  <p>Page(s) 113</p>	12,00–25,99 mm	~ 7 x D	k7	IT10	R _a 1–4 μm
<p>Chamfer module</p>  <p>Page(s) 117</p>	12,00–19,99 mm	–	–	–	–

1) Variations can occur depending on the material and the cutting data used.

2) Drill depth, cutting data, coolant pressure and material can cause deterioration of the surface finish.

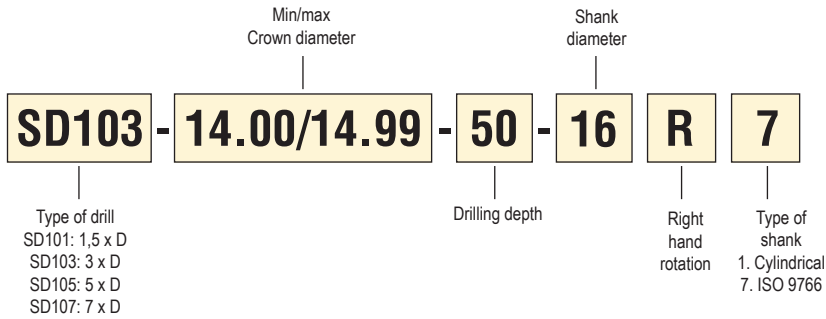

Code key Crownloc®

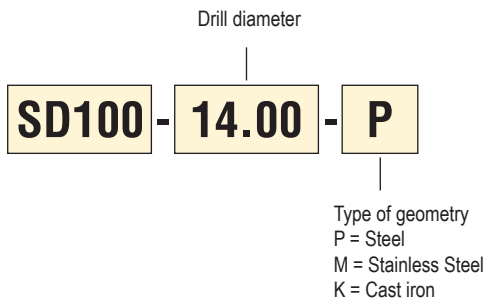

Code key Crowns



Geometries

<p>P-geometry - Universal geometry, first choice for drilling in steel</p> 	<p>M-geometry - For stainless steels and high temp alloys</p> 	<p>K-geometry - First choice for drilling in cast iron</p> 
---	--	--

Mounting instructions

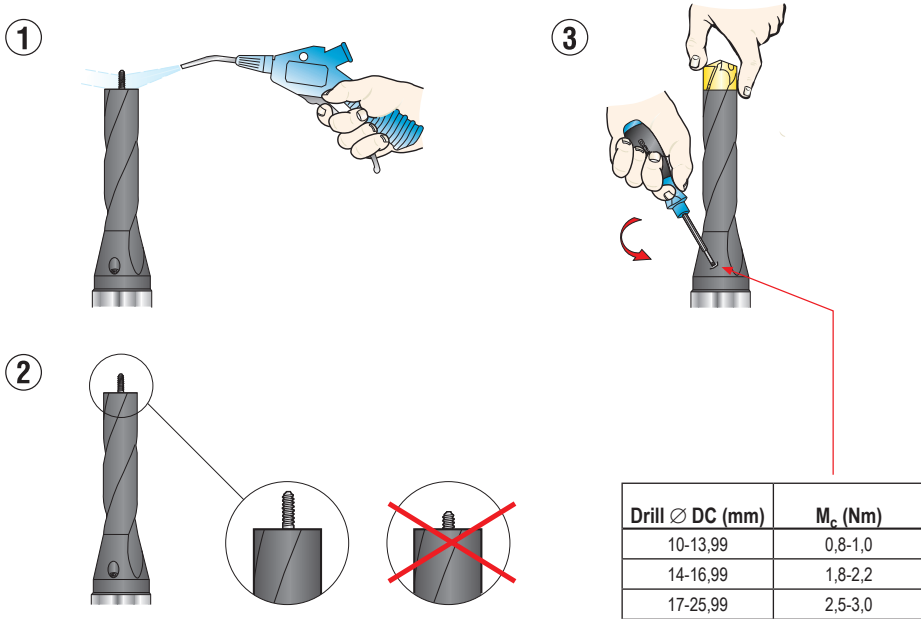

1. Clean the locking interface of the drill body carefully to remove any chips or debris.
2. Make sure that the pull rod is fully extended.
3. Mount new crown onto the pull rod and turn it until it reaches the bottom of the thread. Turn the crown slightly counterclockwise (backwards) until the locking interfaces fit. Push the crown towards the body into the right position while turning the clamping screw. Make sure the interfaces fit. Tighten the clamping screw firmly using the torque key.

Stability

The stability of the application is important in obtaining the best tool life and hole accuracy. Check the condition of the machine spindle, fixture and fixturing of the component to secure maximum stability and rigidity. Unstable conditions can cause tool breakages.

Rotating

Total Indicated Run-out (TIR) should not exceed 0,06 mm in a rotating application. Measure the run-out when the drill is mounted in the spindle.

Stationary

The distance between the drill point and the rotating centre of the workpiece should not exceed 0.03 mm radially in a stationary application.

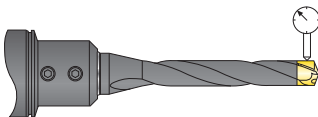

Recommended tool holders

For best results, use holders type DIN 1835 B/DIN 6535 HB (Weldon). For further information see Tooling Systems catalogue.



Weldon

Drilling depth ~ 1,5 x D

SD101 -R7 shank



- Internal coolant
- ISO9766 fits holders: Weldon 1835B, ISO 5414, DIN 60880
- For cutting data see page(s) 129

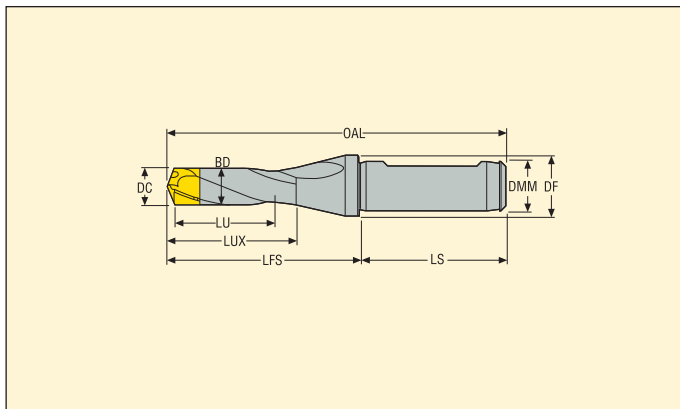

DC	LU	Ordering and Product No.	Designation	Dimensions in mm							
				OAL	BD	LUX	LFS	LS	DMM	DF	
12,0-12,49	20	02445790	SD101-12.00/12.49-20-16R7	96,0	11,5	32,0	48,0	48	16	20	
12,5-12,99	20	02445791	SD101-12.50/12.99-20-16R7	96,4	12,0	32,4	48,4	48	16	20	
13,0-13,99	20	02445792	SD101-13.00/13.99-20-16R7	96,8	12,5	32,8	48,8	48	16	20	
14,0-14,99	25	02445793	SD101-14.00/14.99-25-16R7	102,4	13,5	38,4	54,4	48	16	20	
15,0-15,99	25	02445794	SD101-15.00/15.99-25-16R7	103,3	14,5	39,3	55,3	48	16	20	
16,0-16,99	25	02445795	SD101-16.00/16.99-25-16R7	104,0	15,5	40,0	56,0	48	16	20	
17,0-17,99	30	02445796	SD101-17.00/17.99-30-20R7	110,7	16,5	44,7	60,7	50	20	25	
18,0-18,99	30	02445797	SD101-18.00/18.99-30-20R7	111,7	17,5	45,7	61,7	50	20	25	
19,0-19,99	30	02445798	SD101-19.00/19.99-30-20R7	112,5	18,5	46,5	62,5	50	20	25	
20,0-21,99	40	02462832	SD101-20.00/21.99-40-25R7	129,5	19,5	53,5	73,5	56	25	31	
22,0-23,99	40	02462833	SD101-22.00/23.99-40-25R7	129,5	21,5	53,5	73,5	56	25	31	
24,0-25,99	40	02462834	SD101-24.00/25.99-40-25R7	129,5	23,5	53,5	73,5	56	25	31	

Spare Parts

For drill dia. (mm)	Locking key	Locking screw	Spare parts set
12,00-13,99	H1.5-2D	MP6SS3X12	SD101-SP-5.0
14,00-16,99	H2.0-2D	MP6SS4X12	SD101-SP-6.0
17,00-19,99	H2.5-2D	MP6SS5X16	SD101-SP-7.0
20,00-25,99	H2.5-2D	MP6SS5X16	SD101-SP-8.0

Accessories*

Torque key	Replacement blade
H00-1509	H00-1.5
H00-2020	H00-2.0
H00-2530	H00-2.5
H00-2535	H00-2.5

*Accessories not included in delivery.

Drilling depth ~ 3 x D

SD103-R7 shank

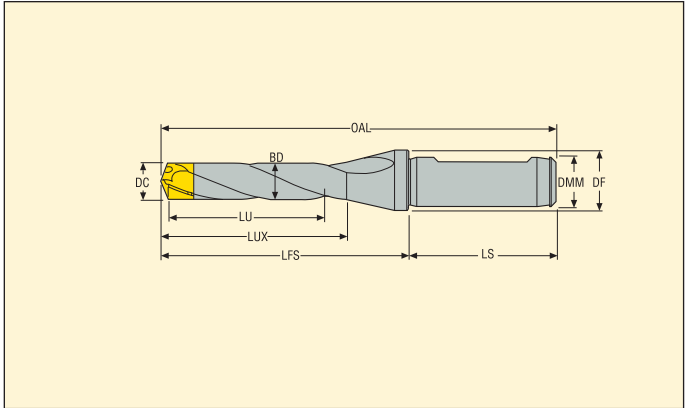

- Internal coolant
- ISO9766 fits holders: Weldon 1835B, ISO 5414, DIN 60880
- For cutting data see page(s) 130

DC	LU	Ordering and Product No.	Designation	Dimensions in mm						
				OAL	BD	LUX	LFS	LS	DMM	DF
10,0-10,49	30	02462815	SD103-10.00/10.49-30-16R7	101,0	9,5	38,0	53,0	48	16	20
10,5-10,99	30	02462818	SD103-10.50/10.99-30-16R7	101,0	10,0	38,0	53,0	48	16	20
11,0-11,49	30	02462819	SD103-11.00/11.49-30-16R7	101,0	10,5	38,0	53,0	48	16	20
11,5-11,99	30	02462820	SD103-11.50/11.99-30-16R7	101,0	11,0	38,0	53,0	48	16	20
12,0-12,49	40	02445799	SD103-12.00/12.49-40-16R7	116,0	11,5	48,0	68,0	48	16	20
12,5-12,99	40	02445800	SD103-12.50/12.99-40-16R7	116,4	12,0	48,4	68,4	48	16	20
13,0-13,99	40	02445801	SD103-13.00/13.99-40-16R7	116,8	12,5	48,8	68,8	48	16	20
14,0-14,99	50	02445802	SD103-14.00/14.99-50-16R7	127,4	13,5	59,4	79,4	48	16	20
15,0-15,99	50	02445803	SD103-15.00/15.99-50-16R7	128,3	14,5	60,3	80,3	48	16	20
16,0-16,99	50	02445804	SD103-16.00/16.99-50-16R7	129,0	15,5	61,0	81,0	48	16	20
17,0-17,99	60	02445805	SD103-17.00/17.99-60-20R7	140,7	16,5	67,7	90,7	50	20	25
18,0-18,99	60	02445806	SD103-18.00/18.99-60-20R7	141,7	17,5	68,7	91,7	50	20	25
19,0-19,99	60	02445807	SD103-19.00/19.99-60-20R7	142,5	18,5	69,5	92,7	50	20	25
20,0-21,99	75	02462836	SD103-20.00/21.99-75-25R7	164,5	19,5	88,5	108,5	56	25	31
22,0-23,99	75	02462838	SD103-22.00/23.99-75-25R7	164,5	21,5	88,5	108,5	56	25	31
24,0-25,99	75	02462841	SD103-24.00/25.99-75-25R7	164,5	23,5	88,5	108,5	56	25	31

Spare Parts

For drill dia. (mm)	Locking key	Locking screw	Spare parts set
10,00-11,99	H1.5-2D	MP6SS3X12	SD103-SP-4.0
12,00-13,99	H1.5-2D	MP6SS3X12	SD103-SP-5.0
14,00-16,99	H2.0-2D	MP6SS4X12	SD103-SP-6.0
17,00-19,99	H2.5-2D	MP6SS5X16	SD103-SP-7.0
20,00-25,99	H2.5-2D	MP6SS5X16	SD103-SP-8.0

Accessories*

Torque key	Replacement blade
H00-1509	H00-1.5
H00-1509	H00-1.5
H00-2020	H00-2.0
H00-2530	H00-2.5
H00-2535	H00-2.5

*Accessories not included in delivery.

Drilling depth ~ 5 x D

SD105-R7 shank



- Internal coolant
- ISO9766 fits holders: Weldon 1835B, ISO 5414, DIN 60880
- For cutting data see page(s) 131

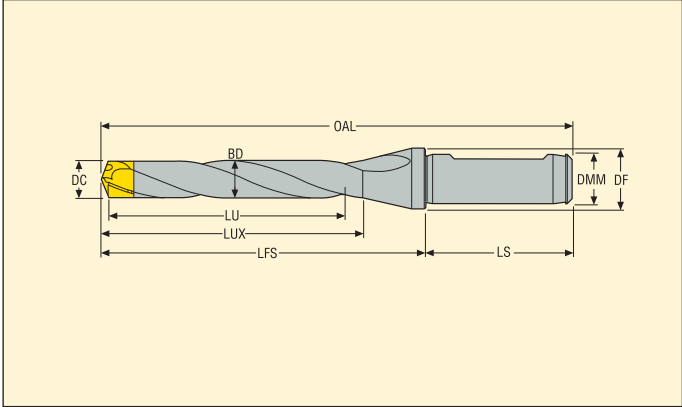

DC	LU	Ordering and Product No.	Designation	Dimensions in mm						
				OAL	BD	LUX	LFS	LS	DMM	DF
10,0-10,49	50	02462822	SD105-10.00/10.49-50-16R7	120,1	9,5	57,3	72,1	48	16	20
10,5-10,99	50	02462824	SD105-10.50/10.99-50-16R7	120,6	10,0	57,3	72,6	48	16	20
11,0-11,49	50	02462828	SD105-11.00/11.49-50-16R7	120,9	10,5	57,3	72,9	48	16	20
11,5-11,99	50	02462830	SD105-11.50/11.99-50-16R7	121,3	11,0	58,3	73,3	48	16	20
12,0-12,49	65	02445808	SD105-12.00/12.49-65-16R7	141,0	11,5	73,0	93,0	48	16	20
12,5-12,99	65	02445809	SD105-12.50/12.99-65-16R7	141,4	12,0	73,4	93,4	48	16	20
13,0-13,99	65	02445810	SD105-13.00/13.99-65-16R7	141,8	12,5	73,8	93,8	48	16	20
14,0-14,99	80	02445811	SD105-14.00/14.99-80-16R7	157,4	13,5	89,4	109,4	48	16	20
15,0-15,99	80	02445812	SD105-15.00/15.99-80-16R7	158,3	14,5	90,3	110,3	48	16	20
16,0-16,99	80	02445813	SD105-16.00/16.99-80-16R7	159,0	15,5	91,0	111,0	48	16	20
17,0-17,99	95	02445814	SD105-17.00/17.99-95-20R7	176,7	16,5	107,7	126,7	50	20	25
18,0-18,99	95	02445815	SD105-18.00/18.99-95-20R7	177,7	17,5	108,7	127,7	50	20	25
19,0-19,99	95	02445816	SD105-19.00/19.99-95-20R7	178,5	18,5	109,5	128,5	50	20	25
20,0-21,99	125	02462843	SD105-20.00/21.99-125-25R7	214,5	19,5	138,5	158,5	56	25	31
22,0-23,99	125	02462848	SD105-22.00/23.99-125-25R7	214,5	21,5	138,5	158,5	56	25	31
24,0-25,99	125	02462850	SD105-24.00/25.99-125-25R7	214,5	23,5	138,5	158,5	56	25	31

Spare Parts

For drill dia. (mm)	Locking key	Locking screw	Spare parts set
10,00-11,99	H1.5-2D	MP6SS3X12	SD105-SP-4.0
12,00-13,99	H1.5-2D	MP6SS3X12	SD105-SP-5.0
14,00-16,99	H2.0-2D	MP6SS4X12	SD105-SP-6.0
17,00-19,99	H2.5-2D	MP6SS5X16	SD105-SP-7.0
20,00-25,99	H2.5-2D	MP6SS5X16	SD105-SP-8.0

Accessories*

Torque key	Replacement blade
H00-1509	H00-1.5
H00-1509	H00-1.5
H00-2020	H00-2.0
H00-2530	H00-2.5
H00-2535	H00-2.5

*Accessories not included in delivery.

Drilling depth ~ 7 x D

SD107 -R7 shank



- Internal coolant
- ISO9766 fits holders: Weldon 1835B, ISO 5414, DIN 60880
- For cutting data see page(s) 132

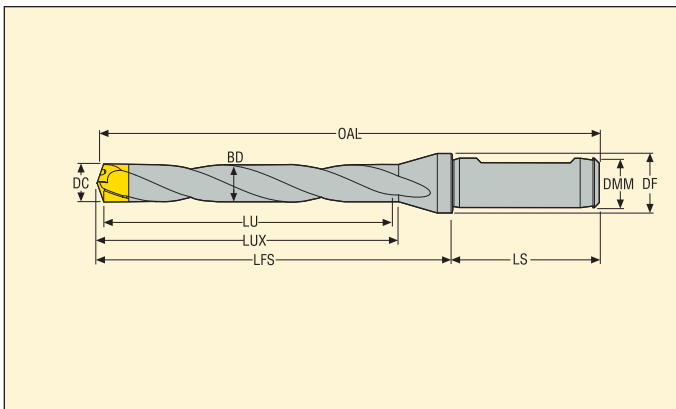

DC	LU	Ordering and Product No.	Designation	Dimensions in mm						
				OAL	BD	LUX	LFS	LS	DMM	DF
12,0-12,49	90	02427470	SD107-12.00/12.49-90-16R7	166,5	11,5	100,5	118,5	48	16	20
12,5-12,99	90	02427472	SD107-12.50/12.99-90-16R7	167,0	12,0	101,0	119,0	48	16	20
13,0-13,99	90	02427473	SD107-13.00/13.99-90-16R7	167,5	12,5	101,5	119,5	48	16	20
14,0-14,99	110	02427474	SD107-14.00/14.99-110-16R7	188,0	13,5	122,0	140,0	48	16	20
15,0-15,99	110	02427476	SD107-15.00/15.99-110-16R7	189,0	14,5	123,0	141,0	48	16	20
16,0-16,99	110	02427443	SD107-16.00/16.99-110-16R7	189,5	15,5	123,5	141,5	48	16	20
17,0-17,99	130	02427478	SD107-17.00/17.99-130-20R7	212,5	16,5	144,5	162,5	50	20	25
18,0-18,99	130	02427479	SD107-18.00/18.99-130-20R7	213,5	17,5	145,5	163,5	50	20	25
19,0-19,99	130	02427480	SD107-19.00/19.99-130-20R7	214,5	18,5	146,5	164,5	50	20	25
20,0-21,99	175	02530422	SD107-20.00/21.99-175-25R7	264,5	19,5	188,5	208,5	56	25	31
22,0-23,99	175	02530423	SD107-22.00/23.99-175-25R7	264,5	21,5	188,5	208,5	56	25	31
24,0-25,99	175	02517867	SD107-24.00/25.99-175-25R7	264,5	23,5	188,5	208,5	56	25	31

Spare Parts

For drill dia. (mm)	Locking key	Locking screw	Spare parts set
12,00-13,99	H1.5-2D	MP6SS3X12	SD107-SP-5.0
14,00-16,99	H2.0-2D	MP6SS4X12	SD107-SP-6.0
17,00-19,99	H2.5-2D	MP6SS5X16	SD107-SP-7.0
20,00-25,99	H2.5-2D	MP6SS5X16	SD107-SP-8.0

Accessories*

Torque key	Replacement blade
H00-1509	H00-1.5
H00-2020	H00-2.0
H00-2530	H00-2.5
H00-2535	H00-2.5

*Accessories not included in delivery.

Crowns – Geometry -P, -M and -K

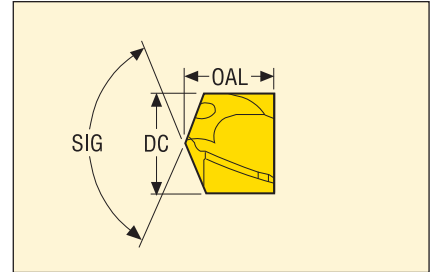
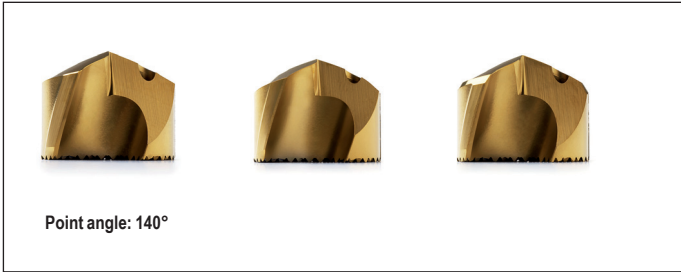

P-geometry for steel	M-geometry for stainless steels and high temp alloys	K-geometry for cast iron	DC	OAL
SD100-9.52-P	SD100-9.52-M	-	9,52	8,08
SD100-10.00-P	SD100-10.00-M	-	10,00	8,1
SD100-10.10-P	-	-	10,10	8,1
SD100-10.20-P	SD100-10.20-M	SD100-10.20-K	10,20	8,1
SD100-10.30-P	-	-	10,30	8,1
SD100-10.319-P	SD100-10.319-M	-	10,319	8,1
SD100-10.40-P	-	-	10,40	8,1
SD100-10.50-P	SD100-10.50-M	SD100-10.50-K	10,50	8,5
SD100-10.70-P	-	-	10,70	8,5
SD100-10.716-P	-	-	10,716	8,5
SD100-10.80-P	SD100-10.80-M	-	10,80	8,5
SD100-10.90-P	-	-	10,90	8,5
SD100-11.00-P	SD100-11.00-M	-	11,00	8,8
SD100-11.113-P	SD100-11.113-M	-	11,113	8,8
SD100-11.20-P	SD100-11.20-M	-	11,20	8,8
SD100-11.30-P	-	-	11,30	8,8
SD100-11.50-P	-	-	11,50	9,4
SD100-11.509-P	SD100-11.509-M	-	11,509	9,4
SD100-11.70-P	-	-	11,70	9,4
SD100-11.80-P	SD100-11.80-M	SD100-11.80-K	11,80	9,4
SD100-11.907-P	SD100-11.907-M	-	11,907	9,4
SD100-12.00-P	SD100-12.00-M	SD100-12.00-K	12,00	9,6
SD100-12.10-P	-	-	12,10	9,6
SD100-12.20-P	-	-	12,20	9,6
SD100-12.30-P	SD100-12.30-M	-	12,30	9,6
SD100-12.41-P	SD100-12.41-M	-	12,41	9,6
SD100-12.50-P	SD100-12.50-M	SD100-12.50-K	12,50	10,0
SD100-12.60-P	-	-	12,60	10,0
SD100-12.70-P	SD100-12.70-M	SD100-12.70-K	12,70	10,0
SD100-12.80-P	SD100-12.80-M	SD100-12.80-K	12,80	10,0
SD100-12.90-P	SD100-12.90-M	-	12,90	10,0
SD100-13.00-P	SD100-13.00-M	SD100-13.00-K	13,00	10,4
SD100-13.10-P	SD100-13.10-M	SD100-13.10-K	13,10	10,4
SD100-13.20-P	-	-	13,20	10,4
SD100-13.30-P	SD100-13.30-M	-	13,30	10,4
SD100-13.50-P	SD100-13.50-M	SD100-13.50-K	13,50	10,4
SD100-13.70-P	SD100-13.70-M	-	13,70	10,4
SD100-13.80-P	SD100-13.80-M	SD100-13.80-K	13,80	10,4
SD100-13.89-P	SD100-13.89-M	-	13,89	10,4
SD100-14.00-P	SD100-14.00-M	SD100-14.00-K	14,00	11,0
SD100-14.10-P	-	-	14,10	11,0
SD100-14.20-P	SD100-14.20-M	SD100-14.20-K	14,20	11,0
SD100-14.29-P	SD100-14.29-M	SD100-14.29-K	14,29	11,0
SD100-14.40-P	-	-	14,40	11,0
SD100-14.50-P	SD100-14.50-M	SD100-14.50-K	14,50	11,0
SD100-14.68-P	SD100-14.68-M	SD100-14.68-K	14,68	11,0
SD100-14.70-P	SD100-14.70-M	-	14,70	11,0
SD100-14.80-P	SD100-14.80-M	-	14,80	11,0
SD100-14.90-P	SD100-14.90-M	-	14,90	11,0
SD100-15.00-P	SD100-15.00-M	SD100-15.00-K	15,00	11,9

Crowns – Geometry -P, -M and -K

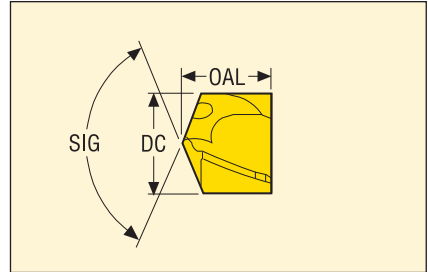
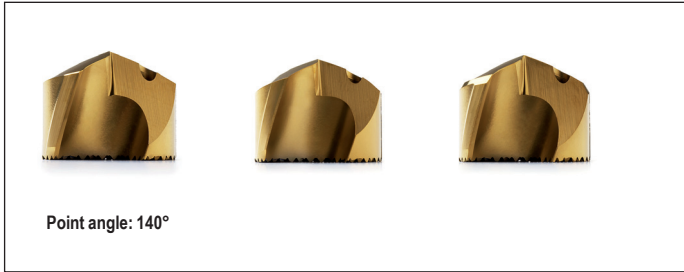

P-geometry for steel	M-geometry for stainless steels and high temp alloys	K-geometry for cast iron	DC	OAL
SD100-15.08-P	SD100-15.08-M	-	15.08	11,9
SD100-15.10-P	-	-	15.10	11,9
SD100-15.20-P	-	-	15.20	11,9
SD100-15.25-P	SD100-15.25-M	SD100-15.25-K	15.25	11,9
SD100-15.48-P	SD100-15.48-M	SD100-15.48-K	15.48	11,9
SD100-15.50-P	SD100-15.50-M	SD100-15.50-K	15.50	11,9
SD100-15.70-P	SD100-15.70-M	-	15.70	11,9
SD100-15.80-P	SD100-15.80-M	SD100-15.80-K	15.80	11,9
SD100-15.88-P	SD100-15.88-M	SD100-15.88-K	15.88	11,9
SD100-16.00-P	SD100-16.00-M	SD100-16.00-K	16.00	12,6
SD100-16.10-P	-	-	16.10	12,6
SD100-16.20-P	-	-	16.20	12,6
SD100-16.25-P	-	-	16.25	12,6
SD100-16.27-P	SD100-16.27-M	SD100-16.27-K	16.27	12,6
SD100-16.40-P	-	-	16.40	12,6
SD100-16.50-P	SD100-16.50-M	SD100-16.50-K	16.50	12,6
SD100-16.67-P	SD100-16.67-M	SD100-16.67-K	16.67	12,6
SD100-16.70-P	SD100-16.70-M	SD100-16.70-K	16.70	12,6
SD100-16.80-P	SD100-16.80-M	SD100-16.80-K	16.80	12,6
SD100-16.90-P	SD100-16.90-M	-	16.90	12,6
SD100-17.00-P	SD100-17.00-M	SD100-17.00-K	17.00	13,3
SD100-17.07-P	SD100-17.07-M	SD100-17.07-K	17.07	13,3
SD100-17.10-P	-	-	17.10	13,3
SD100-17.20-P	-	SD100-17.20-K	17.20	13,3
-	-	SD100-17.30-K	17.30	13,3
SD100-17.46-P	SD100-17.46-M	-	17.46	13,3
SD100-17.50-P	SD100-17.50-M	SD100-17.50-K	17.50	13,3
SD100-17.70-P	SD100-17.70-M	SD100-17.70-K	17.70	13,3
SD100-17.80-P	SD100-17.80-M	SD100-17.80-K	17.80	13,3
SD100-17.86-P	SD100-17.86-M	SD100-17.86-K	17.86	13,3
SD100-17.90-P	SD100-17.90-M	-	17.90	13,3
SD100-18.00-P	SD100-18.00-M	SD100-18.00-K	18.00	14,4
SD100-18.10-P	-	-	18.10	14,4
SD100-18.20-P	-	-	18.20	14,4
SD100-18.26-P	SD100-18.26-M	SD100-18.26-K	18.26	14,4
SD100-18.50-P	SD100-18.50-M	SD100-18.50-K	18.50	14,4
SD100-18.65-P	SD100-18.65-M	-	18.65	14,4
SD100-18.70-P	SD100-18.70-M	-	18.70	14,4
SD100-18.80-P	SD100-18.80-M	SD100-18.80-K	18.80	14,4
SD100-18.90-P	SD100-18.90-M	-	18.90	14,4
SD100-19.00-P	SD100-19.00-M	SD100-19.00-K	19.00	15,2
SD100-19.05-P	SD100-19.05-M	SD100-19.05-K	19.05	15,2
SD100-19.10-P	-	-	19.10	15,2
SD100-19.20-P	SD100-19.20-M	SD100-19.20-K	19.20	15,2
SD100-19.25-P	-	-	19.25	15,2
SD100-19.45-P	SD100-19.45-M	SD100-19.45-K	19.45	15,2
SD100-19.50-P	SD100-19.50-M	SD100-19.50-K	19.50	15,2
SD100-19.70-P	SD100-19.70-M	SD100-19.70-K	19.70	15,2
SD100-19.80-P	SD100-19.80-M	SD100-19.80-K	19.80	15,2
SD100-19.84-P	SD100-19.84-M	-	19.84	15,2

Crowns – Geometry -P, -M and -K

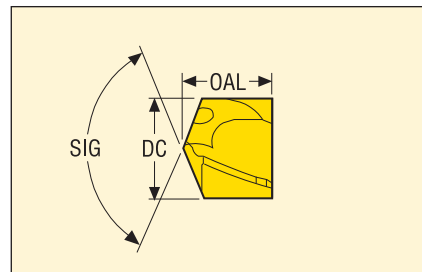
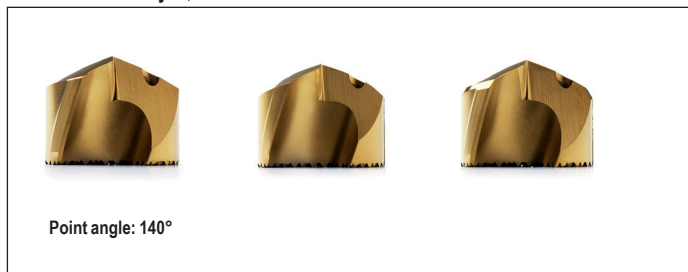

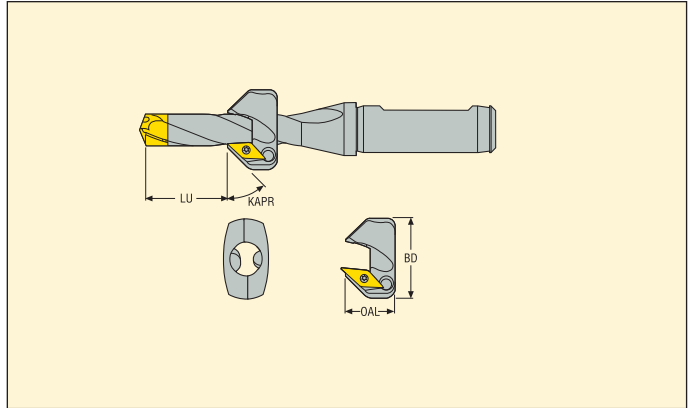

P-geometry for steel	M-geometry for stainless steels and high temp alloys	K-geometry for cast iron	DC	OAL
SD100-19.90-P	SD100-19.90-M	-	19,90	15,2
SD100-19.99-P	-	-	19,99	15,2
SD100-20.00-P	SD100-20.00-M	SD100-20.00-K	20,00	15,2
SD100-20.241-P	-	-	20,241	15,2
SD100-20.50-P	SD100-20.50-M	SD100-20.50-K	20,50	15,2
SD100-20.638-P	SD100-20.638-M	-	20,638	15,2
SD100-20.80-P	-	-	20,80	15,2
SD100-20.90-P	-	-	20,90	15,2
SD100-21.00-P	SD100-21.00-M	SD100-21.00-K	21,00	15,2
SD100-21.034-P	-	-	21,034	15,2
SD100-21.20-P	-	-	21,20	15,2
SD100-21.30-P	-	-	21,30	15,2
SD100-21.430-P	SD100-21.430-M	-	21,430	15,2
SD100-21.50-P	SD100-21.50-M	SD100-21.50-K	21,50	15,2
SD100-21.80-P	SD100-21.80-M	SD100-21.80-K	21,80	15,2
SD100-21.829-P	-	-	21,829	15,2
SD100-21.90-P	SD100-21.90-M	-	21,90	15,2
SD100-22.00-P	SD100-22.00-M	SD100-22.00-K	22,00	15,2
SD100-22.225-P	SD100-22.225-M	-	22,225	15,2
SD100-22.50-P	SD100-22.50-M	SD100-22.50-K	22,50	15,2
SD100-22.621-P	-	-	22,621	15,2
SD100-22.80-P	SD100-22.80-M	-	22,80	15,2
SD100-22.90-P	-	-	22,90	15,2
SD100-23.00-P	SD100-23.00-M	SD100-23.00-K	23,00	15,2
SD100-23.416-P	-	-	23,416	15,2
SD100-23.50-P	SD100-23.50-M	SD100-23.50-K	23,50	15,2
SD100-23.813-P	SD100-23.813-M	SD100-23.813-K	23,813	15,2
SD100-23.90-P	SD100-23.90-M	-	23,90	15,2
SD100-24.00-P	SD100-24.00-M	SD100-24.00-K	24,00	15,2
SD100-24.209-P	-	-	24,209	15,2
SD100-24.50-P	SD100-24.50-M	SD100-24.50-K	24,50	15,2
SD100-24.605-P	-	-	24,605	15,2
SD100-24.80-P	SD100-24.80-M	SD100-24.80-K	24,80	15,2
SD100-24.90-P	SD100-24.90-M	-	24,90	15,2
SD100-25.00-P	SD100-25.00-M	SD100-25.00-K	25,00	15,2
-	-	SD100-25.40-K	25,40	15,2
SD100-25.400-P	SD100-25.400-M	-	25,400	15,2
SD100-25.50-P	-	-	25,50	15,2
SD100-25.60-P	-	-	25,60	15,2
SD100-25.80-P	SD100-25.80-M	-	25,80	15,2
SD100-25.90-P	SD100-25.90-M	-	25,90	15,2
SD100-25.99-P	-	SD100-25.99-K	25,99	15,2

Chamfer module



Ordering and Product No.	Designation	For drill body	Drill depth LU					Max chamfer depth	OAL	BD
			SD101 (min-max)	SD103 (min-max)	SD105 (min-max)	SD107 (min-max)				
00014922	SD100-C45-12.00/12.49	SD10x-12.00/12.49	12,0-13,0	12,0-28,0	28,0-53,0	53,0-78,0	1,5	19	28	
00014923	SD100-C45-12.50/12.99	SD10x-12.50/12.99	12,0-14,0	12,0-29,0	29,0-54,0	54,0-79,0	1,5	19	28	
00014924	SD100-C45-13.00/13.99	SD10x-13.00/13.99	13,0-14,0	13,0-29,0	29,0-54,0	54,0-79,0	1,5	19	28	
00014928	SD100-C45-14.00/14.99	SD10x-14.00/14.99	14,0-20,0	14,0-40,0	40,0-70,0	70,0-100,0	2,0	19	31	
00014931	SD100-C45-15.00/15.99	SD10x-15.00/15.99	14,0-21,0	14,0-41,0	41,0-71,0	71,0-101,0	2,0	19	31	
00014932	SD100-C45-16.00/16.99	SD10x-16.00/16.99	15,0-22,0	15,0-42,0	42,0-72,0	72,0-102,0	2,0	19	31	
00014933	SD100-C45-17.00/17.99	SD10x-17.00/17.99	16,0-25,0	16,0-51,0	51,0-87,0	87,0-123,0	2,0	19	36	
00014935	SD100-C45-18.00/18.99	SD10x-18.00/18.99	17,0-26,0	17,0-52,0	52,0-88,0	88,0-124,0	2,0	19	36	
00014936	SD100-C45-19.00/19.99	SD10x-19.00/19.99	18,0-27,0	18,0-53,0	53,0-89,0	89,0-125,0	2,0	19	36	

Spare Parts, included in delivery

For drill dia (mm)	Insert screw	Insert key	Locking key
			
	Insert	Module	Module
SD100-12.00-16.99	C02505-T07P	C04011-T15P	T07P-2
SD100-17.00-19.99	C02505-T07P	C05012-T15P	T07P-2

Insert

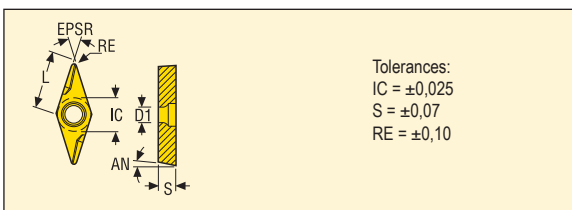

Size	Dimensions in mm				
	IC	L	S	D1	RE
09	5,556	9,000	2,500	2,900	0,2
Grade	T400D				
Designation	VCGX090202-D1				
Ordering and Product No.	00014948				

Chamfer module – Mounting instruction/placement of module

1

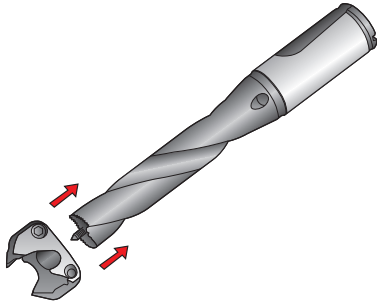

Fit the module on the drill without chamfer insert or crown mounted.

2

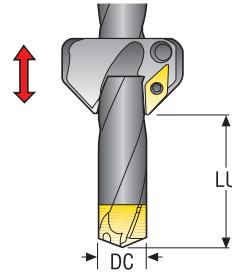

If possible, place the module as close to the shank as possible.

DC		LU drilling depth			
		SD101 (min-max)		SD103 (min-max)	
(mm)	(inch)	(mm)	(inch)	(mm)	(inch)
12	.472	12-13	.472-.512	12-28	.472-1.102
12,5	.492	12-14	.472-.551	12-29	.472-1.142
13	.512	13-14	.512-.551	13-29	.512-1.142
14	.551	14-20	.551-.787	14-40	.551-1.575
15	.591	14-21	.551-.827	14-41	.551-1.614
16	.630	15-22	.591-.866	15-42	.591-1.654
17	.669	16-25	.630-.984	16-51	.630-2.008
18	.709	17-26	.669-1.024	17-52	.669-2.047
19	.748	18-27	.709-1.063	18-53	.709-2.087

3

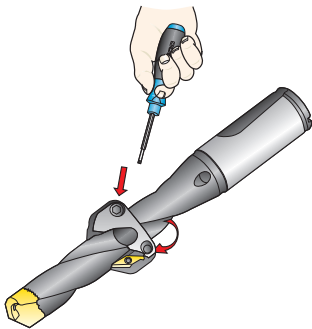

DC		M	
(mm)	(inch)	(Nm)	(in-lbs)
12-19	.472-.748	3-4	26-35

Tighten both screws according to the table above.

2

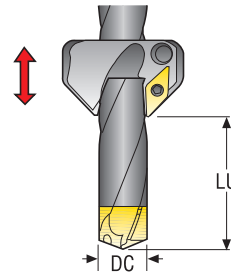

If possible, place the module as close to the shank as possible.

DC		LU drilling depth			
		SD105 (min-max)		SD107 (min-max)	
(mm)	(inch)	(mm)	(inch)	(mm)	(inch)
12	.472	28-53	1.102-2.087	53-78	2.087-3.071
12,5	.492	29-54	1.142-2.126	54-79	2.126-3.110
13	.512	29-54	1.142-2.126	54-79	2.126-3.110
14	.551	40-70	1.575-2.756	70-100	2.756-3.937
15	.591	41-71	1.614-2.785	71-101	2.795-3.976
16	.630	42-72	1.654-2.835	72-102	2.835-4.016
17	.669	51-87	2.008-3.425	87-123	3.425-4.843
18	.709	52-88	2.047-3.465	88-124	3.465-4.882
19	.748	53-89	2.087-3.504	89-125	3.504-4.921

Chamfer module – Cutting data

The recommended cutting speeds and feeds for Crownloc® on page 129-132 should also be used during the chamfering operation.

Troubleshooting

<p>Vibrations during chamfering</p>	<ul style="list-style-type: none"> • Reduce cutting speed • If possible, move the module closer to the shank of the drill. • If possible, use a shorter drill
--	--

Maximum chamfer depth

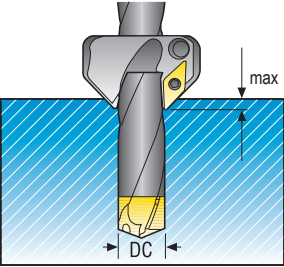

DC		Max	
(mm)	(inch)	(mm)	(inch)
12-13	.472- .512	1,5	.059
14-19	.551- .748	2	.079

Cutting data – SD101 – Ø10-26

SMG		f									v _c
		Ø10.00	Ø12.00	Ø14.00	Ø16.00	Ø18.00	Ø20.00	Ø22.00	Ø24.00	Ø26.00	
P1	P	0,20	0,24	0,26	0,28	0,30	0,32	0,34	0,34	0,36	125
P2	P	0,20	0,24	0,26	0,28	0,30	0,32	0,34	0,36	0,36	120
P3	P	0,19	0,22	0,24	0,26	0,28	0,30	0,32	0,34	0,34	105
P4	P	0,19	0,22	0,24	0,26	0,28	0,30	0,32	0,32	0,34	95
P5	P	0,19	0,22	0,24	0,26	0,28	0,30	0,30	0,32	0,34	90
P6	P	0,18	0,22	0,24	0,26	0,28	0,28	0,30	0,32	0,32	100
P7	P	0,18	0,22	0,24	0,26	0,28	0,28	0,30	0,32	0,32	95
P8	P	0,19	0,22	0,24	0,26	0,28	0,30	0,32	0,34	0,34	90
P11	P	0,18	0,22	0,24	0,26	0,28	0,28	0,30	0,32	0,32	90
P12	P	0,13	0,15	0,16	0,18	0,19	0,20	0,20	0,22	0,22	55
M1	M	0,14	0,15	0,15	0,16	0,16	0,16	0,17	0,17	0,17	85
M2	M	0,13	0,13	0,14	0,14	0,15	0,15	0,15	0,16	0,16	70
M3	M	0,10	0,11	0,11	0,11	0,12	0,12	0,12	0,12	0,13	50
M4	M	0,090	0,095	0,095	0,10	0,10	0,10	0,11	0,11	0,11	39
M5	M	0,090	0,095	0,095	0,10	0,10	0,10	0,11	0,11	0,11	33
K1	K	0,28	0,32	0,34	0,36	0,38	0,40	0,42	0,42	0,44	100
K2	K	0,26	0,28	0,30	0,32	0,34	0,36	0,38	0,38	0,40	85
K3	K	0,26	0,28	0,30	0,32	0,34	0,36	0,38	0,38	0,40	70
K4	K	0,26	0,28	0,30	0,32	0,34	0,36	0,38	0,38	0,40	70
K5	K	0,24	0,26	0,28	0,30	0,32	0,32	0,34	0,36	0,36	41
N1	M	0,18	0,19	0,19	0,20	0,20	0,20	0,22	0,22	0,22	335
N2	M	0,18	0,19	0,19	0,20	0,20	0,20	0,22	0,22	0,22	215
N3	M	0,18	0,19	0,19	0,20	0,20	0,20	0,22	0,22	0,22	145
N11	M	0,18	0,19	0,19	0,20	0,20	0,20	0,22	0,22	0,22	170
S1	M	0,090	0,095	0,095	0,10	0,10	0,10	0,11	0,11	0,11	34
S2	M	0,090	0,095	0,095	0,10	0,10	0,10	0,11	0,11	0,11	25
S3	M	0,085	0,085	0,090	0,095	0,095	0,095	0,10	0,10	0,10	25
S11	M	0,10	0,11	0,11	0,11	0,12	0,12	0,12	0,12	0,13	65
S12	M	0,10	0,11	0,11	0,11	0,12	0,12	0,12	0,12	0,13	49
S13	M	0,090	0,095	0,095	0,10	0,10	0,10	0,11	0,11	0,11	38
H3	P	0,085	0,095	0,11	0,12	0,12	0,13	0,14	0,14	0,15	27
H5	P	0,13	0,15	0,16	0,18	0,19	0,20	0,20	0,22	0,22	50
H7	P	0,085	0,095	0,11	0,12	0,12	0,13	0,14	0,14	0,15	27
H8	P	0,095	0,11	0,12	0,13	0,14	0,15	0,16	0,17	0,17	50
H11	P	0,13	0,15	0,16	0,18	0,19	0,20	0,20	0,22	0,22	65
H12	P	0,095	0,11	0,12	0,13	0,14	0,15	0,16	0,17	0,17	32
H21	P	0,095	0,11	0,12	0,13	0,14	0,15	0,16	0,17	0,17	50

SMG = Seco material group

f = mm/rev

v_c = m/min

All cutting data are start values

Cutting data – SD103 – Ø10-26

SMG		f									v _c
		Ø10.00	Ø12.00	Ø14.00	Ø16.00	Ø18.00	Ø20.00	Ø22.00	Ø24.00	Ø26.00	
P1	P	0,20	0,24	0,26	0,28	0,30	0,32	0,34	0,34	0,36	120
P2	P	0,20	0,24	0,26	0,28	0,30	0,32	0,34	0,36	0,36	115
P3	P	0,19	0,22	0,24	0,26	0,28	0,30	0,32	0,34	0,34	100
P4	P	0,19	0,22	0,24	0,26	0,28	0,30	0,32	0,32	0,34	85
P5	P	0,19	0,22	0,24	0,26	0,28	0,30	0,30	0,32	0,34	85
P6	P	0,18	0,22	0,24	0,26	0,28	0,28	0,30	0,32	0,32	95
P7	P	0,18	0,22	0,24	0,26	0,28	0,28	0,30	0,32	0,32	90
P8	P	0,19	0,22	0,24	0,26	0,28	0,30	0,32	0,34	0,34	85
P11	P	0,18	0,22	0,24	0,26	0,28	0,28	0,30	0,32	0,32	85
P12	P	0,13	0,15	0,16	0,18	0,19	0,20	0,20	0,22	0,22	50
M1	M	0,14	0,15	0,15	0,16	0,16	0,16	0,17	0,17	0,17	80
M2	M	0,13	0,13	0,14	0,14	0,15	0,15	0,15	0,16	0,16	65
M3	M	0,10	0,11	0,11	0,11	0,12	0,12	0,12	0,12	0,13	49
M4	M	0,090	0,095	0,095	0,10	0,10	0,10	0,11	0,11	0,11	37
M5	M	0,090	0,095	0,095	0,10	0,10	0,10	0,11	0,11	0,11	31
K1	K	0,28	0,32	0,34	0,36	0,38	0,40	0,42	0,42	0,44	90
K2	K	0,26	0,28	0,30	0,32	0,34	0,36	0,38	0,38	0,40	80
K3	K	0,26	0,28	0,30	0,32	0,34	0,36	0,38	0,38	0,40	65
K4	K	0,26	0,28	0,30	0,32	0,34	0,36	0,38	0,38	0,40	65
K5	K	0,24	0,26	0,28	0,30	0,32	0,32	0,34	0,36	0,36	38
N1	M	0,18	0,19	0,19	0,20	0,20	0,20	0,22	0,22	0,22	315
N2	M	0,18	0,19	0,19	0,20	0,20	0,20	0,22	0,22	0,22	200
N3	M	0,18	0,19	0,19	0,20	0,20	0,20	0,22	0,22	0,22	135
N11	M	0,18	0,19	0,19	0,20	0,20	0,20	0,22	0,22	0,22	160
S1	M	0,090	0,095	0,095	0,10	0,10	0,10	0,11	0,11	0,11	32
S2	M	0,090	0,095	0,095	0,10	0,10	0,10	0,11	0,11	0,11	23
S3	M	0,085	0,085	0,090	0,095	0,095	0,095	0,10	0,10	0,10	23
S11	M	0,10	0,11	0,11	0,11	0,12	0,12	0,12	0,12	0,13	60
S12	M	0,10	0,11	0,11	0,11	0,12	0,12	0,12	0,12	0,13	46
S13	M	0,090	0,095	0,095	0,10	0,10	0,10	0,11	0,11	0,11	36
H3	P	0,085	0,095	0,11	0,12	0,12	0,13	0,14	0,14	0,15	25
H5	P	0,13	0,15	0,16	0,18	0,19	0,20	0,20	0,22	0,22	46
H7	P	0,085	0,095	0,11	0,12	0,12	0,13	0,14	0,14	0,15	25
H8	P	0,095	0,11	0,12	0,13	0,14	0,15	0,16	0,17	0,17	46
H11	P	0,13	0,15	0,16	0,18	0,19	0,20	0,20	0,22	0,22	60
H12	P	0,095	0,11	0,12	0,13	0,14	0,15	0,16	0,17	0,17	30
H21	P	0,095	0,11	0,12	0,13	0,14	0,15	0,16	0,17	0,17	46

SMG = Seco material group

f = mm/rev

v_c = m/min

All cutting data are start values

Cutting data-SD105 - Ø10-26

SMG		f									v _c
		Ø10.00	Ø12.00	Ø14.00	Ø16.00	Ø18.00	Ø20.00	Ø22.00	Ø24.00	Ø26.00	
P1	P	0,20	0,24	0,26	0,28	0,30	0,32	0,34	0,34	0,36	110
P2	P	0,20	0,24	0,26	0,28	0,30	0,32	0,34	0,36	0,36	110
P3	P	0,19	0,22	0,24	0,26	0,28	0,30	0,32	0,34	0,34	95
P4	P	0,19	0,22	0,24	0,26	0,28	0,30	0,32	0,32	0,34	85
P5	P	0,19	0,22	0,24	0,26	0,28	0,30	0,30	0,32	0,34	80
P6	P	0,18	0,22	0,24	0,26	0,28	0,28	0,30	0,32	0,32	90
P7	P	0,18	0,22	0,24	0,26	0,28	0,28	0,30	0,32	0,32	85
P8	P	0,19	0,22	0,24	0,26	0,28	0,30	0,32	0,34	0,34	80
P11	P	0,18	0,22	0,24	0,26	0,28	0,28	0,30	0,32	0,32	80
P12	P	0,13	0,15	0,16	0,18	0,19	0,20	0,20	0,22	0,22	48
M1	M	0,14	0,15	0,15	0,16	0,16	0,16	0,17	0,17	0,17	75
M2	M	0,13	0,13	0,14	0,14	0,15	0,15	0,15	0,16	0,16	60
M3	M	0,10	0,11	0,11	0,11	0,12	0,12	0,12	0,12	0,13	46
M4	M	0,090	0,095	0,095	0,10	0,10	0,10	0,11	0,11	0,11	35
M5	M	0,090	0,095	0,095	0,10	0,10	0,10	0,11	0,11	0,11	29
K1	K	0,28	0,32	0,34	0,36	0,38	0,40	0,42	0,42	0,44	90
K2	K	0,26	0,28	0,30	0,32	0,34	0,36	0,38	0,38	0,40	75
K3	K	0,26	0,28	0,30	0,32	0,34	0,36	0,38	0,38	0,40	65
K4	K	0,26	0,28	0,30	0,32	0,34	0,36	0,38	0,38	0,40	60
K5	K	0,24	0,26	0,28	0,30	0,32	0,32	0,34	0,36	0,36	36
N1	M	0,18	0,19	0,19	0,20	0,20	0,20	0,22	0,22	0,22	300
N2	M	0,18	0,19	0,19	0,20	0,20	0,20	0,22	0,22	0,22	190
N3	M	0,18	0,19	0,19	0,20	0,20	0,20	0,22	0,22	0,22	130
N11	M	0,18	0,19	0,19	0,20	0,20	0,20	0,22	0,22	0,22	150
S1	M	0,090	0,095	0,095	0,10	0,10	0,10	0,11	0,11	0,11	30
S2	M	0,090	0,095	0,095	0,10	0,10	0,10	0,11	0,11	0,11	22
S3	M	0,085	0,085	0,090	0,095	0,095	0,095	0,10	0,10	0,10	22
S11	M	0,10	0,11	0,11	0,11	0,12	0,12	0,12	0,12	0,13	55
S12	M	0,10	0,11	0,11	0,11	0,12	0,12	0,12	0,12	0,13	44
S13	M	0,090	0,095	0,095	0,10	0,10	0,10	0,11	0,11	0,11	34
H3	P	0,085	0,095	0,11	0,12	0,12	0,13	0,14	0,14	0,15	24
H5	P	0,13	0,15	0,16	0,18	0,19	0,20	0,20	0,22	0,22	44
H7	P	0,085	0,095	0,11	0,12	0,12	0,13	0,14	0,14	0,15	24
H8	P	0,095	0,11	0,12	0,13	0,14	0,15	0,16	0,17	0,17	44
H11	P	0,13	0,15	0,16	0,18	0,19	0,20	0,20	0,22	0,22	55
H12	P	0,095	0,11	0,12	0,13	0,14	0,15	0,16	0,17	0,17	29
H21	P	0,095	0,11	0,12	0,13	0,14	0,15	0,16	0,17	0,17	44

SMG = Seco material group

f = mm/rev

v_c = m/min

All cutting data are start values

Cutting data – SD107 – Ø12-26

SMG		f								v _c
		Ø12.00	Ø14.00	Ø16.00	Ø18.00	Ø20.00	Ø22.00	Ø24.00	Ø26.00	
P1	P	0,24	0,26	0,28	0,30	0,32	0,34	0,34	0,36	110
P2	P	0,24	0,26	0,28	0,30	0,32	0,34	0,36	0,36	105
P3	P	0,22	0,24	0,26	0,28	0,30	0,32	0,34	0,34	90
P4	P	0,22	0,24	0,26	0,28	0,30	0,32	0,32	0,34	80
P5	P	0,22	0,24	0,26	0,28	0,30	0,30	0,32	0,34	75
P6	P	0,22	0,24	0,26	0,28	0,28	0,30	0,32	0,32	85
P7	P	0,22	0,24	0,26	0,28	0,28	0,30	0,32	0,32	80
P8	P	0,22	0,24	0,26	0,28	0,30	0,32	0,34	0,34	75
P11	P	0,22	0,24	0,26	0,28	0,28	0,30	0,32	0,32	80
P12	P	0,15	0,16	0,18	0,19	0,20	0,20	0,22	0,22	47
M1	M	0,15	0,15	0,16	0,16	0,16	0,17	0,17	0,17	75
M2	M	0,13	0,14	0,14	0,15	0,15	0,15	0,16	0,16	60
M3	M	0,11	0,11	0,11	0,12	0,12	0,12	0,12	0,13	45
M4	M	0,095	0,095	0,10	0,10	0,10	0,11	0,11	0,11	34
M5	M	0,095	0,095	0,10	0,10	0,10	0,11	0,11	0,11	28
K1	K	0,32	0,34	0,36	0,38	0,40	0,42	0,42	0,44	85
K2	K	0,28	0,30	0,32	0,34	0,36	0,38	0,38	0,40	75
K3	K	0,28	0,30	0,32	0,34	0,36	0,38	0,38	0,40	60
K4	K	0,28	0,30	0,32	0,34	0,36	0,38	0,38	0,40	60
K5	K	0,26	0,28	0,30	0,32	0,32	0,34	0,36	0,36	35
N1	M	0,19	0,19	0,20	0,20	0,20	0,22	0,22	0,22	290
N2	M	0,19	0,19	0,20	0,20	0,20	0,22	0,22	0,22	185
N3	M	0,19	0,19	0,20	0,20	0,20	0,22	0,22	0,22	125
N11	M	0,19	0,19	0,20	0,20	0,20	0,22	0,22	0,22	145
S1	M	0,095	0,095	0,10	0,10	0,10	0,11	0,11	0,11	29
S2	M	0,095	0,095	0,10	0,10	0,10	0,11	0,11	0,11	21
S3	M	0,085	0,090	0,095	0,095	0,095	0,10	0,10	0,10	21
S11	M	0,11	0,11	0,11	0,12	0,12	0,12	0,12	0,13	55
S12	M	0,11	0,11	0,11	0,12	0,12	0,12	0,12	0,13	42
S13	M	0,095	0,095	0,10	0,10	0,10	0,11	0,11	0,11	33
H3	P	0,095	0,11	0,12	0,12	0,13	0,14	0,14	0,15	23
H5	P	0,15	0,16	0,18	0,19	0,20	0,20	0,22	0,22	43
H7	P	0,095	0,11	0,12	0,12	0,13	0,14	0,14	0,15	23
H8	P	0,11	0,12	0,13	0,14	0,15	0,16	0,17	0,17	43
H11	P	0,15	0,16	0,18	0,19	0,20	0,20	0,22	0,22	55
H12	P	0,11	0,12	0,13	0,14	0,15	0,16	0,17	0,17	28
H21	P	0,11	0,12	0,13	0,14	0,15	0,16	0,17	0,17	43

SMG = Seco material group

f = mm/rev

v_c = m/min

All cutting data are start values

Custom design – No waiting for quotations – Short delivery time

You can now design your own customised Crownloc® drill body or Crownloc® crown using the Custom Design software.

The concept gives you a number of advantages:

- No waiting for quotations! price and delivery time available instantly
- Directly visualises your needs. No risk of misunderstandings
- Short delivery time



CUSTOM DESIGN

Drilling >> CrownLoc® >> Single Diameter >> Single Diameter >> Single Diameter
[Feedback](#)

[Back](#)
[Start Page](#)
English ▼

[Print this page](#)

Step 1: Tool Specification

Step 2: Request for Quotation

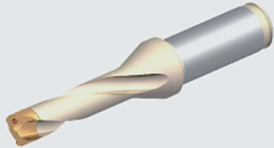
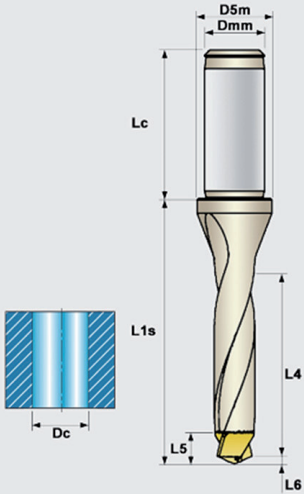
	Min	Max	
Dc	10	25.99	20.3
L4	20	175	106
With flange	<input checked="" type="checkbox"/>		
Type of shank	ISO 9766 (R7) i		
Shank size	25 ▼		
L1s (±0.5)	139		
Lc	56		
L5	15.2		
L6	3.7		
Dmm (h6)	25		
D5m	32		

Previous
Next

Spare Parts / Inserts

Note Inserts have to be ordered separately

Designation
 SD109-20.00/21.99-106-25R7

Delivery Time

Quantity: Get data

Please contact your local Seco representative for more information.

Different types of custom drills – Detailed information can be found in the Custom Design software

A1. Single diameter

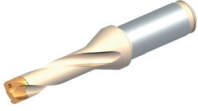

A2. Reinforced

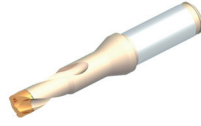

A3. Chamfer

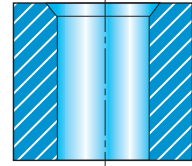
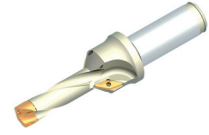

A4. Face

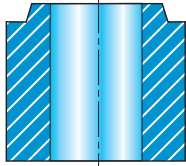
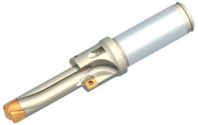

A5. Face with chamfer

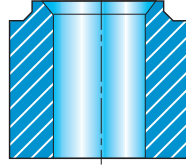
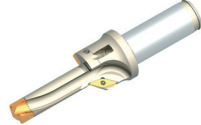

A6. Straight chip flutes

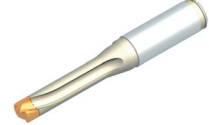

B1. Counterbore

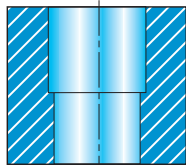
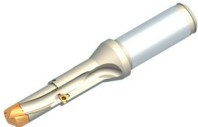

B2. Counterbore and chamfer

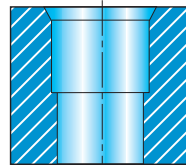
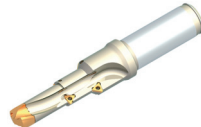





CUSTOM DESIGN

Drilling >> CrownLoc® Inserts >> Bottom profile >> Step
Feedback

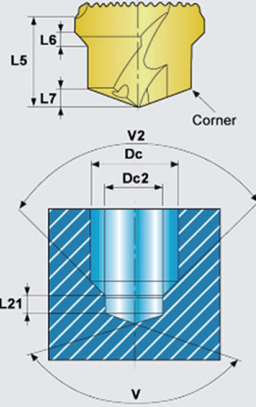

Back
Start Page
English

 [Print this page](#)

Step 1: Tool Specification

Step 2: Request for Quotation

	Min	Max	
Dc (k7)	10	25.99	19.7
Hole tolerances			H9-H11
V (±2°)	100	140	140
Dc2 (k7)	14	19.7	16.4
V2 (±2°)	60	180	132
L21 (±0.1)	0	8.8	5.8
Application			P 
Corner			Standard 
L5			13.44
L6			0.73
L7			2.98
Coating			TiAlN
Edge preparation			Medium

Previous
Next

Designation
SD100-B3-19.70-3570480-P

Delivery Time
Quantity: Get data
Min Quantity: 2

Please contact your local Seco representative for more information.

Different types of custom drills – Detailed information can be found in the Custom Design software

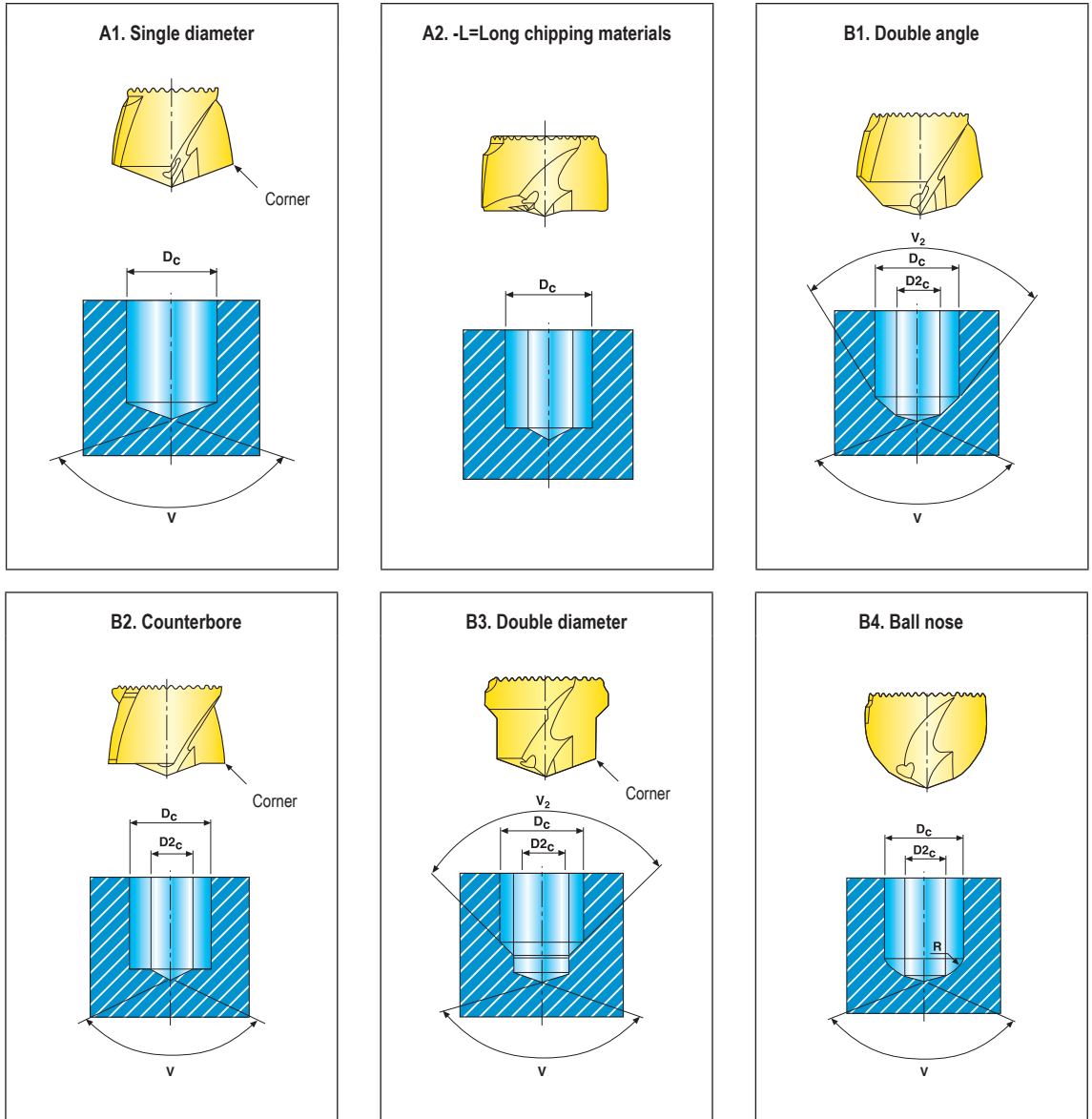

Drilling diameter,
 $D_c = 10,00 - 25,99$
 Geometry: P = Steel
 M = Stainless Steel
 K = Cast iron
 L = Long chipping materials
 N = Non-ferrous materials
 H = Hardened steels
 Corner: Standard, chamfer, radius
 V: 100–150° (standard = 140°)

Available with 10 and 13 percent cobalt
 for more wear resistance.
 Ex: SD100-15.00-K10.

Machining data

The values in the graphs vary with e.g. cutting data, material, efficiency of the machine and tool wear. The graphs below are valid for Seco Material Group (SMG) P5-P6 and cutting speed 90 m/min.

Net power consumption

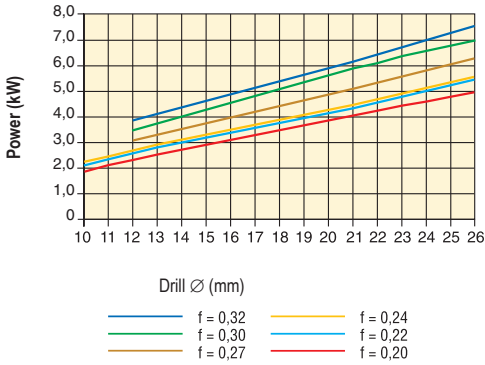

Drilling torque

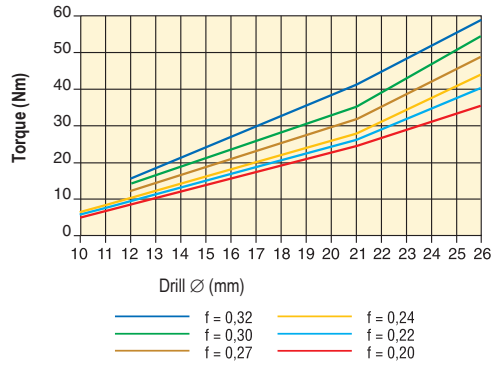

Feed force

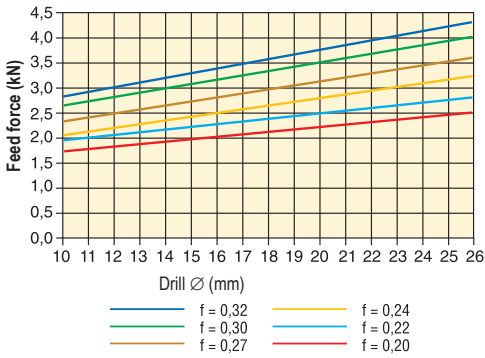

Coolant flow at different pressures

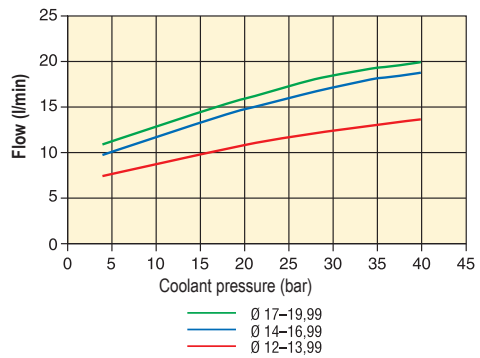

Hole tolerances/Surface finish

SD101, SD103, SD105 and SD107 IT9-10 / R _a 1-4*		
Drill Ø DC (mm)	IT9 tolerance (µm)	IT10 tolerance (µm)
10-18	43	70
18-30	52	84

*Deterioration of surface finish and hole tolerance can occur when drilling in low carbon steel or stainless steel. Use the shortest drill possible for best hole quality.

Recommended coolant flow Dx1 l/min

Minimum coolant flow D/2 l/min

D = Drill diameter

Minimum recommended coolant pressure 10 bar with < 3 x D

Minimum recommended coolant pressure 20 bar with > 3 x D

Minimum recommended coolant pressure 40 bar with > 5 x D

Coolant mix

Recommended emulsion mix is 6-8%.

When drilling in stainless steels, superalloys and high strength steels a mix of 10% is recommended.





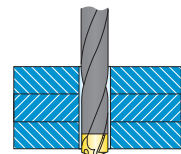

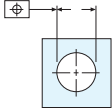

Machining recommendations

It is possible to drill stacked material as long as the pieces are securely clamped together, so that there are no air gaps between the parts. Air gaps can affect chip evacuation, and thereby damage the drill.

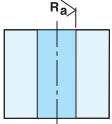

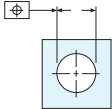

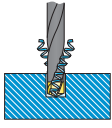
Troubleshooting – Initial check points:

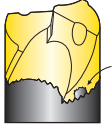
- Fixturing stability
- Machine spindle condition
- Tool holder condition
- Clamping of tool:
 - Run-out within 0.06 TIR
- Chip evacuation:
 - Cutting data
- Coolant:
 - Pressure
 - Flow
 - Concentration

<p>Cutting edges get chipped</p> <ul style="list-style-type: none"> • Reduce the feed/rev • If the drill vibrates, reduce the cutting speed and increase the feed rate • When drilling through rough, hard or angled surfaces, reduce the feed rate by 30%-50% during entrance and exit 	<p>Unsatisfactory diameter tolerance</p> <ul style="list-style-type: none"> • Increase the feed/rev • Use a Seco Feedmax solid carbide drill, see page(s) 18-21 • Use a reaming operation, see page(s) 231 • Use a boring operation, see page(s) 387-388 
<p>Too fast flank wear</p> <ul style="list-style-type: none"> • Check that correct geometry is used • Reduce the cutting speed 	<p>Unsatisfactory surface finish</p> <ul style="list-style-type: none"> • Reduce the feed/rev • Increase the cutting speed • Check that the correct geometry is used • Use a Seco Feedmax solid carbide drill, see page(s) 18-21 • Use a reaming operation, see page(s) 231 
<p>Groove wear</p> <ul style="list-style-type: none"> • Reduce the feed /rev • Reduce the cutting speed • Increase the coolant concentration 	<p>Unsatisfactory positioning of the hole</p> <ul style="list-style-type: none"> • Reduce the feed/rev • If drilling through rough, hard and angled surface - reduce the feed by 30%-50% during entrance and exit • Pre drill with a 140° point angle • Use a Seco Feedmax solid carbide drill see Feedmax page(s) 18-21 • Use a boring operation, see page(s) 387-388 
<p>Wear of peripheral land margins</p> <ul style="list-style-type: none"> • Check that the correct geometry is used • Reduce the cutting speed • Increase the coolant concentration • When drilling through rough, hard or angled surfaces, reduce the feed rate by 30%-50% during entrance and exit 	<p>Chip jamming due to long chips</p> <ul style="list-style-type: none"> • Increase the feed • In long chipping materials SMG P1-P4, SMG M1-M2: <ul style="list-style-type: none"> - Increase cutting speed and reduce feed/rev - Use the L geometry (Custom Design) 
<p>Breakage at hole exit</p> <ul style="list-style-type: none"> • If the crown connection breaks when the crown is just about to break through the material. The failure is caused by: <ul style="list-style-type: none"> • The interface has not been cleaned thoroughly and there is still dirt or chips left between crown and drill body • The crown has not been clamped securely. Use the torque key • Too few threads are holding the crown 	<p>Chipping of the locking interface</p> <ul style="list-style-type: none"> • Minor chipping is not hazardous to the locking system. It will not affect the drilling result • If major chipping occurs when using a high feed rate or when drilling through angled surfaces - reduce the feed rate 



Range overview

Crownloc® Plus	∅ Range	Drill depth	Crown tolerance	Hole tolerance (1)	Surface finish (2)
<p>SD403</p>  <p>Page(s) 134-135</p>	12,00–19,99 mm	~ 3 x D	k7	IT9-10	R _a 1–3 μm
<p>SD405</p>  <p>Page(s) 136-137</p>	12,00–19,99 mm	~ 5 x D	k7	IT10	R _a 1–3 μm
<p>SD408</p>  <p>Page(s) 138-139</p>	12,00–19,99 mm	~ 8 x D	k7	IT10	R _a 1–3 μm

1) Variations can occur depending on the material and the cutting data used.

2) Drill depth, cutting data, coolant pressure and material can cause deterioration of the surface finish.

Code key Crownloc® Plus

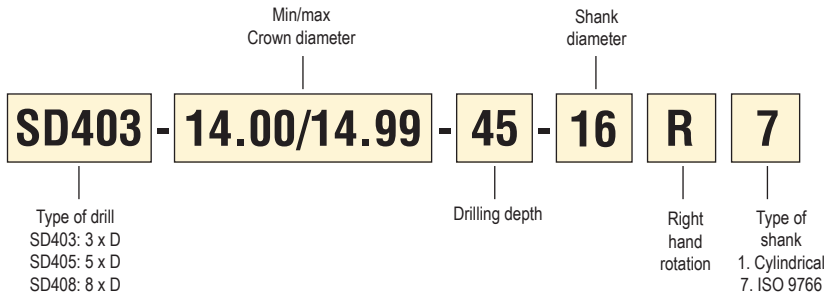

Code key Crowns

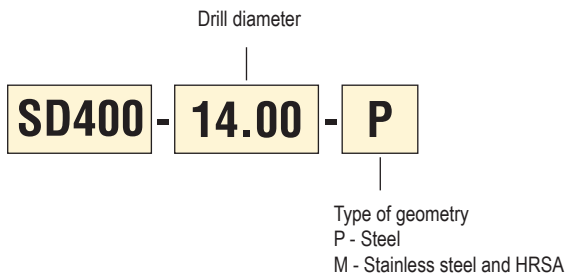

Mounting instructions

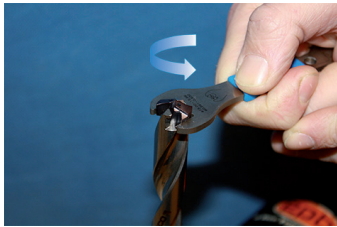
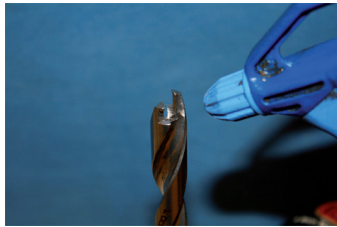
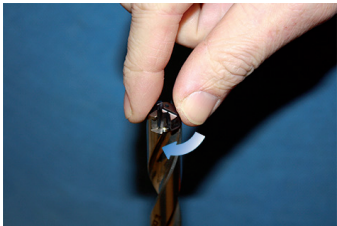
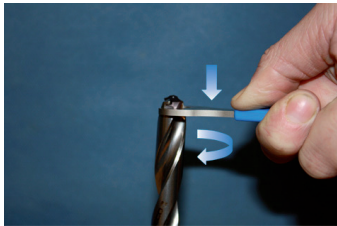
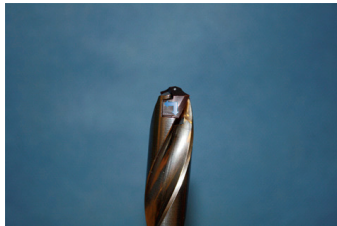
<p>1.</p>  <p>To unclamp the crown, find the two flats on the Crown for the key.</p>	<p>2.</p>  <p>Turn the key counterclockwise to unclamp it with a quarter of a turn.</p>	<p>3.</p>  <p>Clean the connection, before mounting the crown.</p>
<p>4.</p>  <p>Pre-clamp the crown with your fingers for easier clamping, before using the key.</p>	<p>5.</p>  <p>Simultaneously press down the crown when clamping on a quarter of a turn clockwise using the key and keep it perpendicular to the drill body.</p>	<p>6.</p>  <p>When the crown is mounted in the drill body, full contact should be achieved in the connection between the supporting surfaces of the drill body and the Crown, see picture.</p>

1. Stability

The stability of the application is important to obtain the best tool life and hole accuracy. Check the condition of the machine spindle, fixture and fixturing of the component to secure maximum stability and rigidity. Unstable conditions can cause tool breakages.

2. Rotating

Total Indicated Run-out (TIR) should not exceed 0,06 mm in a rotating application. Measure the run-out when turning the drill 360° in the spindle.

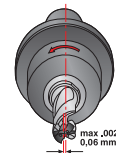

3. Stationary

The distance between the drill point and the rotating centre of the workpiece should not exceed 0.03 mm radially in a stationary application.

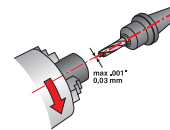

4. Recommended tool holders

For best results, use holders type BT JIS B 6339-ADB, Type 5672, High precision chuck. For further information see Tooling Systems catalogue.



Weldon



Hydraulic chuck
(For cylindrical, -R1 shanks only)



High precision collet chuck
(For cylindrical, -R1 shanks only)

Drilling depth ~ 3 x D

SD403 -R7 shank

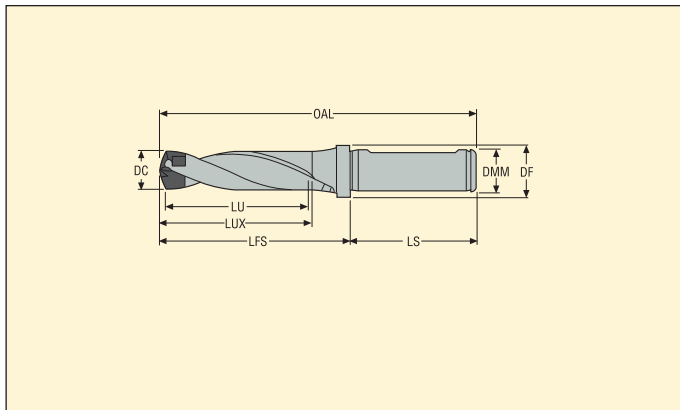

- Internal coolant
- ISO9766 fits holders: Weldon 1835B, ISO 5414, DIN 60880
- For cutting data see page(s) 152

DC	LU	Ordering and Product No.	Designation	Dimensions in mm					
				OAL	LUX	LFS	LS	DMM	DF
12,0-12,49	38	02622894	SD403-12.00/12.49-38-16R7	106,2	46,2	58,2	48	16	20
12,5-12,99	39	02622895	SD403-12.50/12.99-39-16R7	108,0	47,5	60,0	48	16	20
13,0-13,99	42	02622896	SD403-13.00/13.99-42-16R7	111,9	50,9	63,9	48	16	20
14,0-14,99	45	02622898	SD403-14.00/14.99-45-16R7	116,5	54,5	68,5	48	16	20
15,0-15,99	48	02622899	SD403-15.00/15.99-48-16R7	121,2	58,2	73,2	48	16	20
16,0-16,99	51	02622900	SD403-16.00/16.99-51-20R7	127,9	61,9	77,9	50	20	24
17,0-17,99	54	02622902	SD403-17.00/17.99-54-20R7	132,6	65,6	82,6	50	20	24
18,0-18,99	57	02622903	SD403-18.00/18.99-57-20R7	137,3	69,3	87,3	50	20	24
19,0-19,99	60	02622905	SD403-19.00/19.99-60-20R7	142,0	73,0	92,0	50	20	24

Accessories*

For drill dia. (mm)	Key	
12,00-12,99	SD400-K05	
13,00-14,99	SD400-K06	
15,00-16,99	SD400-K07	
17,00-18,99	SD400-K08	
19,00-19,99	SD400-K09	

*Accessories not included in delivery.

Drilling depth ~ 3 x D

SD403-R1 shank



- Internal coolant
- Cylindrical shank (R1) fits holders: 5834 and 5672
- For cutting data see page(s) 152

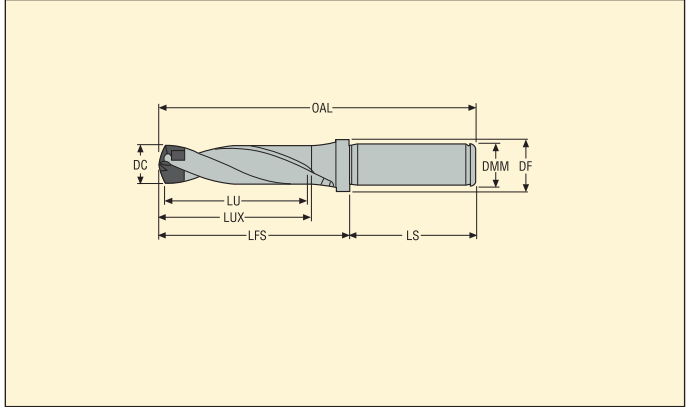

DC	LU	Ordering and Product No.	Designation	Dimensions in mm					
				OAL	LUX	LFS	LS	DMM	DF
12,0-12,49	38	02622920	SD403-12.00/12.49-38-16R1	106,2	46,2	58,2	48	16	20
12,5-12,99	39	02622921	SD403-12.50/12.99-39-16R1	108,0	47,5	60,0	48	16	20
13,0-13,99	42	02622922	SD403-13.00/13.99-42-16R1	111,9	50,9	63,9	48	16	20
14,0-14,99	45	02622923	SD403-14.00/14.99-45-16R1	116,5	54,5	68,5	48	16	20
15,0-15,99	48	02622924	SD403-15.00/15.99-48-16R1	121,2	58,2	73,2	48	16	20
16,0-16,99	51	02622927	SD403-16.00/16.99-51-20R1	127,9	61,9	77,9	50	20	24
17,0-17,99	54	02622928	SD403-17.00/17.99-54-20R1	132,6	65,6	82,6	50	20	24
18,0-18,99	57	02622930	SD403-18.00/18.99-57-20R1	137,3	69,3	87,3	50	20	24
19,0-19,99	60	02622931	SD403-19.00/19.99-60-20R1	142,0	73,0	92,0	50	20	24

Accessories*

For drill dia. (mm)	Key	
12,00-12,99	SD400-K05	
13,00-14,99	SD400-K06	
15,00-16,99	SD400-K07	
17,00-18,99	SD400-K08	
19,00-19,99	SD400-K09	

*Accessories not included in delivery.

Drilling depth ~ 5 x D

SD405-R7 shank

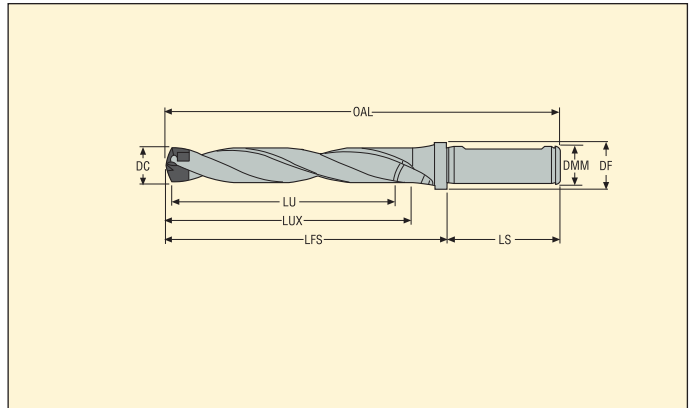

- Internal coolant
- ISO9766 fits holders: Weldon 1835B, ISO 5414, DIN 60880
- For cutting data see page(s) 153

DC	LU	Ordering and Product No.	Designation	Dimensions in mm					
				OAL	LUX	LFS	LS	DMM	DF
12,0-12,49	63	02623554	SD405-12.00/12.49-63-16R7	131,2	71,2	83,2	48	16	20
12,5-12,99	65	02623555	SD405-12.50/12.99-65-16R7	134,0	73,5	86,0	48	16	20
13,0-13,99	70	02623556	SD405-13.00/13.99-70-16R7	139,9	78,9	91,9	48	16	20
14,0-14,99	75	02623557	SD405-14.00/14.99-75-16R7	146,5	84,5	98,5	48	16	20
15,0-15,99	80	02623558	SD405-15.00/15.99-80-16R7	153,2	90,2	105,2	48	16	20
16,0-16,99	85	02623559	SD405-16.00/16.99-85-20R7	161,9	95,9	111,9	50	20	24
17,0-17,99	90	02623560	SD405-17.00/17.99-90-20R7	168,6	101,6	118,6	50	20	24
18,0-18,99	95	02623561	SD405-18.00/18.99-95-20R7	175,3	107,3	125,3	50	20	24
19,0-19,99	100	02623562	SD405-19.00/19.99-100-20R7	182,0	113,0	132,0	50	20	24

Accessories*

For drill dia. (mm)	Key	
12,00-12,99	SD400-K05	
13,00-14,99	SD400-K06	
15,00-16,99	SD400-K07	
17,00-18,99	SD400-K08	
19,00-19,99	SD400-K09	

*Accessories not included in delivery.

SD405-R1 shank

SD405-R1 shank



- Internal coolant
- Cylindrical shank (R1) fits holders: 5834 and 5672
- For cutting data see page(s) 153

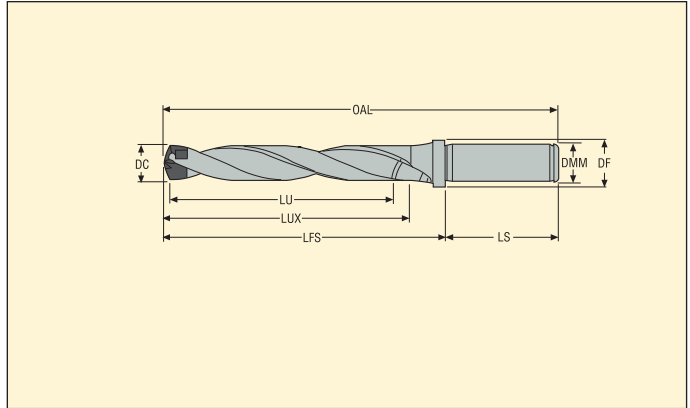

DC	LU	Ordering and Product No.	Designation	Dimensions in mm					
				OAL	LUX	LFS	LS	DMM	DF
12,0-12,49	63	02623570	SD405-12.00/12.49-63-16R1	131,2	71,2	83,2	48	16	20
12,5-12,99	65	02623571	SD405-12.50/12.99-65-16R1	134,0	73,5	86,0	48	16	20
13,0-13,99	70	02623572	SD405-13.00/13.99-70-16R1	139,9	78,9	91,9	48	16	20
14,0-14,99	75	02623573	SD405-14.00/14.99-75-16R1	146,5	84,5	98,5	48	16	20
15,0-15,99	80	02623574	SD405-15.00/15.99-80-16R1	153,2	90,2	105,2	48	16	20
16,0-16,99	85	02623575	SD405-16.00/16.99-85-20R1	161,9	95,9	111,9	50	20	24
17,0-17,99	90	02623576	SD405-17.00/17.99-90-20R1	168,6	101,6	118,6	50	20	24
18,0-18,99	95	02623577	SD405-18.00/18.99-95-20R1	175,3	107,3	125,3	50	20	24
19,0-19,99	100	02623578	SD405-19.00/19.99-100-20R1	182,0	113,0	132,0	50	20	24

Accessories*

For drill dia. (mm)	Key	
12,00-12,99	SD400-K05	
13,00-14,99	SD400-K06	
15,00-16,99	SD400-K07	
17,00-18,99	SD400-K08	
19,00-19,99	SD400-K09	

*Accessories not included in delivery.

Drilling depth 8 x D

SD408 -R7 shank

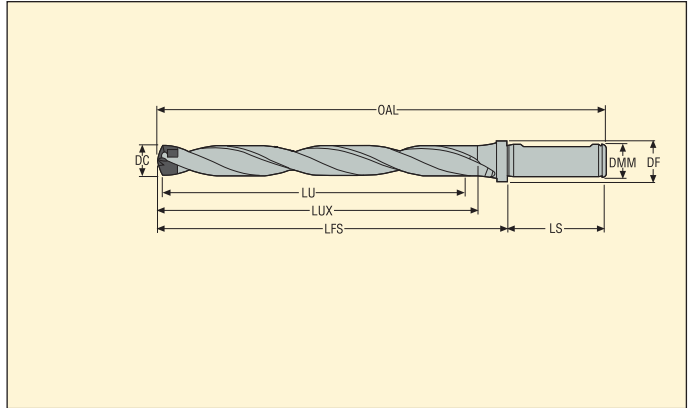

- Internal coolant
- ISO9766 fits holders: Weldon 1835B, ISO 5414, DIN 60880
- For cutting data see page(s) 154

DC	LU	Ordering and Product No.	Designation	Dimensions in mm					
				OAL	LUX	LFS	LS	DMM	DF
12,0-12,49	100	02623615	SD408-12.00/12.49-100-16R7	168,2	108,2	120,2	48	16	20
12,5-12,99	104	02623616	SD408-12.50/12.99-104-16R7	173,0	112,5	125,0	48	16	20
13,0-13,99	112	02623617	SD408-13.00/13.99-112-16R7	181,9	120,9	133,9	48	16	20
14,0-14,99	120	02623618	SD408-14.00/14.99-120-16R7	191,5	129,5	143,5	48	16	20
15,0-15,99	128	02623619	SD408-15.00/15.99-128-16R7	201,2	138,2	153,2	48	16	20
16,0-16,99	136	02623620	SD408-16.00/16.99-136-20R7	212,9	146,9	162,9	50	20	24
17,0-17,99	144	02623621	SD408-17.00/17.99-144-20R7	222,6	155,6	172,6	50	20	24
18,0-18,99	152	02623622	SD408-18.00/18.99-152-20R7	232,3	164,3	182,3	50	20	24
19,0-19,99	160	02623623	SD408-19.00/19.99-160-20R7	242,0	173,0	192,0	50	20	24

Accessories*

For drill dia. (mm)	Key	
12,00-12,99	SD400-K05	
13,00-14,99	SD400-K06	
15,00-16,99	SD400-K07	
17,00-18,99	SD400-K08	
19,00-19,99	SD400-K09	

*Accessories not included in delivery.

Drilling depth 8 x D

SD408 -R1 shank

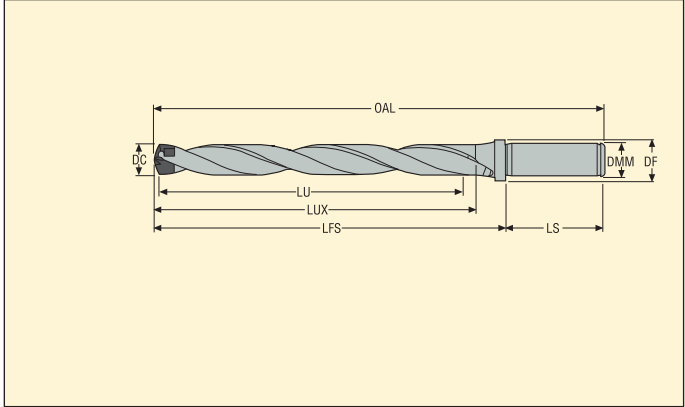

- Internal coolant
- Cylindrical shank (R1) fits holders: 5834 and 5672
- For cutting data see page(s) 154

DC	LU	Ordering and Product No.	Designation	Dimensions in mm					
				OAL	LUX	LFS	LS	DMM	DF
12,0-12,49	100	02623627	SD408-12.00/12.49-100-16R1	168,2	108,2	120,2	48	16	20
12,5-12,99	104	02623628	SD408-12.50/12.99-104-16R1	173,0	112,5	125,0	48	16	20
13,0-13,99	112	02623629	SD408-13.00/13.99-112-16R1	181,9	120,9	133,9	48	16	20
14,0-14,99	120	02623630	SD408-14.00/14.99-120-16R1	191,5	129,5	143,5	48	16	20
15,0-15,99	128	02623631	SD408-15.00/15.99-128-16R1	201,2	138,2	153,2	48	16	20
16,0-16,99	136	02623632	SD408-16.00/16.99-136-20R1	212,9	146,9	162,9	50	20	24
17,0-17,99	144	02623633	SD408-17.00/17.99-144-20R1	222,6	155,6	172,6	50	20	24
18,0-18,99	152	02623634	SD408-18.00/18.99-152-20R1	232,3	164,3	182,3	50	20	24
19,0-19,99	160	02623635	SD408-19.00/19.99-160-20R1	242,0	173,0	192,0	50	20	24

Accessories*

For drill dia. (mm)	Key	
12,00-12,99	SD400-K05	
13,00-14,99	SD400-K06	
15,00-16,99	SD400-K07	
17,00-18,99	SD400-K08	
19,00-19,99	SD400-K09	

*Accessories not included in delivery.

Chamfer module

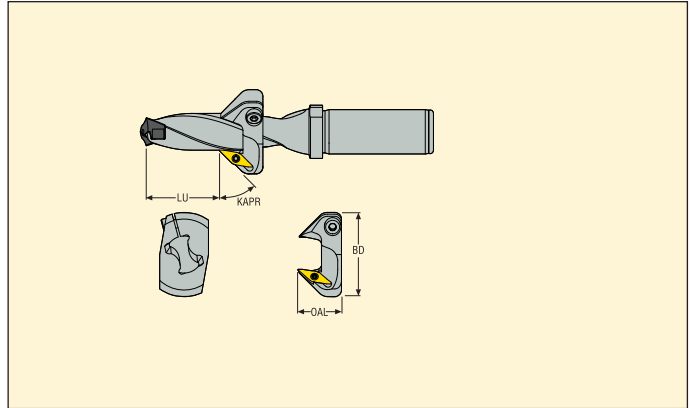

Ordering and Product No.	Designation	For drill body	Drill depth LU				OAL	BD
			SD403 (min-max)	SD405 (min-max)	SD408 (min-max)	Max chamfer depth		
02846075	SD400-C45-12.00/12.49	SD40x-12.00/12.49	6,0-22,0	6,0-47,0	47,0-84,0	1,5	20	34
02846076	SD400-C45-12.50/12.99	SD40x-12.50/12.99	7,0-23,0	7,0-48,0	48,0-88,0	1,5	20	34
02846077	SD400-C45-13.00/13.99	SD40x-13.00/13.99	7,0-27,0	7,0-55,0	55,0-97,0	1,5	20	34
02846078	SD400-C45-14.00/14.99	SD40x-14.00/14.99	7,0-33,0	7,0-60,0	60,0-105,0	1,5	20	36
02846079	SD400-C45-15.00/15.99	SD40x-15.00/15.99	8,0-35,0	8,0-67,0	67,0-114,0	1,5	20	36
02846080	SD400-C45-16.00/16.99	SD40x-16.00/16.99	8,0-38,0	8,0-72,0	72,0-123,0	1,5	20	38
02846117	SD400-C45-17.00/17.99	SD40x-17.00/17.99	9,0-43,0	9,0-79,0	79,0-132,0	1,5	20	38
02846082	SD400-C45-18.00/18.99	SD40x-18.00/18.99	9,0-45,0	9,0-83,0	83,0-140,0	1,5	20	40
02846083	SD400-C45-19.00/19.99	SD40x-19.00/19.99	10,0-49,0	10,0-89,0	89,0-149,0	1,5	20	40

Spare Parts, included in delivery

For drill dia (mm)	Insert key	Insert screw	Locking key	Locking key	Locking screw 1	Locking screw 2
SD400-C45...	T07P-2	C02505-T07P	2SMS795	3SMS795	MC6S4X8	P6SS4X8

Insert

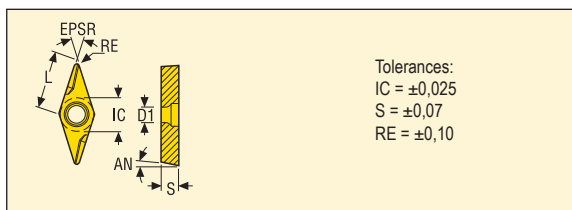

Size	Dimensions in mm				
	IC	L	S	D1	RE
09	5,556	9,000	2,500	2,900	0,2
Grade	T400D				
Designation	VCGX090202-D1				
Ordering and Product No.	00014948				

Crowns – Geometry -P and -M

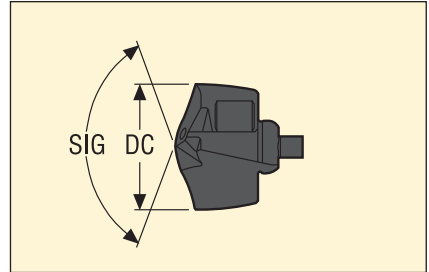

P-geometry for steel	M-geometry for stainless steels and high temp alloys	DC (inch)	DC (mm)
SD400-12.00-P	SD400-12.00-M	0.472	12,00
SD400-12.10-P	-	0.476	12,10
SD400-12.20-P	-	0.480	12,20
SD400-12.30-P	SD400-12.30-M	0.484	12,30
SD400-12.41-P	SD400-12.41-M	0.489	12,41
SD400-12.50-P	SD400-12.50-M	0.492	12,50
SD400-12.60-P	-	0.496	12,60
SD400-12.70-P	SD400-12.70-M	0.500	12,70
SD400-12.80-P	SD400-12.80-M	0.504	12,80
SD400-12.90-P	SD400-12.90-M	0.508	12,90
SD400-13.00-P	SD400-13.00-M	0.512	13,00
SD400-13.10-P	SD400-13.10-M	0.516	13,10
SD400-13.20-P	-	0.520	13,20
SD400-13.30-P	SD400-13.30-M	0.524	13,30
SD400-13.50-P	SD400-13.50-M	0.531	13,50
SD400-13.70-P	SD400-13.70-M	0.539	13,70
SD400-13.80-P	SD400-13.80-M	0.543	13,80
SD400-13.89-P	SD400-13.89-M	0.547	13,89
SD400-14.00-P	SD400-14.00-M	0.551	14,00
SD400-14.10-P	-	0.555	14,10
SD400-14.20-P	SD400-14.20-M	0.559	14,20
SD400-14.288-P	SD400-14.288-M	0.563	14,288
SD400-14.40-P	-	0.567	14,40
SD400-14.50-P	SD400-14.50-M	0.571	14,50
SD400-14.68-P	SD400-14.68-M	0.578	14,68
SD400-14.70-P	SD400-14.70-M	0.579	14,70
SD400-14.80-P	SD400-14.80-M	0.583	14,80
SD400-14.90-P	SD400-14.90-M	0.587	14,90
SD400-15.00-P	SD400-15.00-M	0.591	15,00
SD400-15.08-P	SD400-15.08-M	0.594	15,08
SD400-15.10-P	-	0.594	15,10
SD400-15.20-P	-	0.598	15,20
SD400-15.25-P	SD400-15.25-M	0.600	15,25
SD400-15.478-P	SD400-15.478-M	0.609	15,478
SD400-15.50-P	SD400-15.50-M	0.610	15,50
SD400-15.70-P	SD400-15.70-M	0.618	15,70
SD400-15.80-P	SD400-15.80-M	0.622	15,80
SD400-15.875-P	SD400-15.875-M	0.625	15,875
SD400-16.00-P	SD400-16.00-M	0.630	16,00
SD400-16.10-P	-	0.634	16,10
SD400-16.20-P	-	0.638	16,20
SD400-16.25-P	-	0.640	16,25
SD400-16.27-P	SD400-16.27-M	0.641	16,27
SD400-16.40-P	-	0.646	16,40
SD400-16.50-P	SD400-16.50-M	0.650	16,50

Crowns – Geometry -P and -M



Point angle: 140°

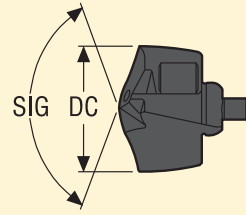

P-geometry for steel	M-geometry for stainless steels and high temp alloys	DC (inch)	DC (mm)
SD400-16.669-P	SD400-16.669-M	0.656	16,669
SD400-16.70-P	SD400-16.70-M	0.657	16,70
SD400-16.80-P	SD400-16.80-M	0.661	16,80
SD400-16.90-P	-	0.665	16,90
SD400-17.00-P	SD400-17.00-M	0.669	17,00
SD400-17.065-P	SD400-17.065-M	0.672	17,065
SD400-17.10-P	-	0.673	17,10
SD400-17.20-P	-	0.677	17,20
SD400-17.35-P	-	0.683	17,35
SD400-17.463-P	SD400-17.463-M	0.688	17,463
SD400-17.50-P	SD400-17.50-M	0.689	17,50
SD400-17.70-P	SD400-17.70-M	0.697	17,70
SD400-17.80-P	SD400-17.80-M	0.701	17,80
SD400-17.859-P	SD400-17.859-M	0.703	17,859
SD400-17.90-P	SD400-17.90-M	0.705	17,90
SD400-18.00-P	SD400-18.00-M	0.709	18,00
SD400-18.10-P	-	0.713	18,10
SD400-18.20-P	-	0.717	18,20
SD400-18.256-P	SD400-18.256-M	0.719	18,256
SD400-18.50-P	SD400-18.50-M	0.728	18,50
SD400-18.653-P	SD400-18.653-M	0.734	18,653
SD400-18.70-P	SD400-18.70-M	0.736	18,70
SD400-18.80-P	SD400-18.80-M	0.740	18,80
SD400-18.90-P	SD400-18.90-M	0.744	18,90
SD400-19.00-P	SD400-19.00-M	0.748	19,00
SD400-19.05-P	SD400-19.05-M	0.750	19,05
SD400-19.10-P	-	0.752	19,10
SD400-19.20-P	SD400-19.20-M	0.756	19,20
-	SD400-19.25-M	0.758	19,25
SD400-19.447-P	SD400-19.447-M	0.766	19,447
SD400-19.50-P	SD400-19.50-M	0.768	19,50
SD400-19.70-P	SD400-19.70-M	0.776	19,70
SD400-19.80-P	SD400-19.80-M	0.780	19,80
SD400-19.844-P	SD400-19.844-M	0.781	19,844
SD400-19.90-P	SD400-19.90-M	0.783	19,90

Cutting data – SD403 – Ø12-20

SMG		f					v _c
		Ø12,00	Ø14,00	Ø16,00	Ø18,00	Ø20,00	
P1	P	0,30	0,32	0,34	0,36	0,36	155
P2	P	0,30	0,32	0,34	0,36	0,38	150
P3	P	0,28	0,30	0,32	0,34	0,36	130
P4	P	0,28	0,30	0,32	0,34	0,34	115
P5	P	0,28	0,30	0,32	0,32	0,34	110
P6	P	0,28	0,30	0,30	0,32	0,34	120
P7	P	0,28	0,30	0,30	0,32	0,34	115
P8	P	0,28	0,30	0,32	0,34	0,36	110
P11	P	0,28	0,30	0,30	0,32	0,34	110
P12	P	0,19	0,20	0,22	0,22	0,24	65
M1	M	0,17	0,19	0,20	0,22	0,22	95
M2	M	0,16	0,17	0,18	0,19	0,20	80
M3	M	0,13	0,14	0,14	0,15	0,16	60
M4	M	0,11	0,12	0,13	0,13	0,14	45
M5	M	0,11	0,12	0,13	0,13	0,14	37
K1	P	0,28	0,30	0,32	0,34	0,36	110
K2	P	0,26	0,28	0,30	0,32	0,32	95
K3	P	0,26	0,28	0,30	0,32	0,32	80
K4	P	0,26	0,28	0,30	0,32	0,32	75
K5	P	0,24	0,26	0,26	0,28	0,30	45
N2	M	0,26	0,28	0,30	0,32	0,34	215
N3	M	0,26	0,28	0,30	0,32	0,34	145
N11	M	0,26	0,28	0,30	0,32	0,34	170
S1	M	0,095	0,11	0,12	0,13	0,13	34
S2	M	0,095	0,11	0,12	0,13	0,13	24
S3	M	0,095	0,11	0,12	0,13	0,13	24
S11	M	0,16	0,17	0,19	0,20	0,22	65
S12	M	0,16	0,17	0,19	0,20	0,22	49
S13	M	0,14	0,15	0,17	0,18	0,19	38
H3	P	0,12	0,13	0,14	0,15	0,15	32
H5	P	0,19	0,20	0,22	0,22	0,24	60
H7	P	0,12	0,13	0,14	0,15	0,15	32
H8	P	0,14	0,15	0,16	0,17	0,18	60
H11	P	0,19	0,20	0,22	0,22	0,24	75
H12	P	0,14	0,15	0,16	0,17	0,18	39
H21	P	0,14	0,15	0,16	0,17	0,18	60

SMG = Seco material group

f = mm/rev

v_c = m/min

All cutting data are start values

Cutting data – SD405 – Ø12-20

SMG		f					v _c
		Ø12,00	Ø14,00	Ø16,00	Ø18,00	Ø20,00	
P1	P	0,30	0,32	0,34	0,36	0,36	125
P2	P	0,30	0,32	0,34	0,36	0,38	120
P3	P	0,28	0,30	0,32	0,34	0,36	105
P4	P	0,28	0,30	0,32	0,34	0,34	95
P5	P	0,28	0,30	0,32	0,32	0,34	90
P6	P	0,28	0,30	0,30	0,32	0,34	100
P7	P	0,28	0,30	0,30	0,32	0,34	95
P8	P	0,28	0,30	0,32	0,34	0,36	90
P11	P	0,28	0,30	0,30	0,32	0,34	90
P12	P	0,19	0,20	0,22	0,22	0,24	55
M1	M	0,17	0,19	0,20	0,22	0,22	80
M2	M	0,16	0,17	0,18	0,19	0,20	65
M3	M	0,13	0,14	0,14	0,15	0,16	49
M4	M	0,11	0,12	0,13	0,13	0,14	37
M5	M	0,11	0,12	0,13	0,13	0,14	31
K1	P	0,28	0,30	0,32	0,34	0,36	90
K2	P	0,26	0,28	0,30	0,32	0,32	75
K3	P	0,26	0,28	0,30	0,32	0,32	65
K4	P	0,26	0,28	0,30	0,32	0,32	60
K5	P	0,24	0,26	0,26	0,28	0,30	37
N2	M	0,26	0,28	0,30	0,32	0,34	175
N3	M	0,26	0,28	0,30	0,32	0,34	120
N11	M	0,26	0,28	0,30	0,32	0,34	140
S1	M	0,095	0,11	0,12	0,13	0,13	28
S2	M	0,095	0,11	0,12	0,13	0,13	20
S3	M	0,095	0,11	0,12	0,13	0,13	20
S11	M	0,16	0,17	0,19	0,20	0,22	50
S12	M	0,16	0,17	0,19	0,20	0,22	40
S13	M	0,14	0,15	0,17	0,18	0,19	31
H3	P	0,12	0,13	0,14	0,15	0,15	26
H5	P	0,19	0,20	0,22	0,22	0,24	49
H7	P	0,12	0,13	0,14	0,15	0,15	26
H8	P	0,14	0,15	0,16	0,17	0,18	49
H11	P	0,19	0,20	0,22	0,22	0,24	60
H12	P	0,14	0,15	0,16	0,17	0,18	32
H21	P	0,14	0,15	0,16	0,17	0,18	49

SMG = Seco material group

f = mm/rev

v_c = m/min

All cutting data are start values

Cutting data – SD408 – Ø12-20

SMG		f					v _c
		Ø12,00	Ø14,00	Ø16,00	Ø18,00	Ø20,00	
P1	P	0,30	0,32	0,34	0,36	0,36	100
P2	P	0,30	0,32	0,34	0,36	0,38	100
P3	P	0,28	0,30	0,32	0,34	0,36	85
P4	P	0,28	0,30	0,32	0,34	0,34	75
P5	P	0,28	0,30	0,32	0,32	0,34	70
P6	P	0,28	0,30	0,30	0,32	0,34	80
P7	P	0,28	0,30	0,30	0,32	0,34	75
P8	P	0,28	0,30	0,32	0,34	0,36	70
P11	P	0,28	0,30	0,30	0,32	0,34	75
P12	P	0,19	0,20	0,22	0,22	0,24	43
M1	M	0,17	0,19	0,20	0,22	0,22	65
M2	M	0,16	0,17	0,18	0,19	0,20	50
M3	M	0,13	0,14	0,14	0,15	0,16	39
M4	M	0,11	0,12	0,13	0,13	0,14	29
M5	M	0,11	0,12	0,13	0,13	0,14	24
K1	P	0,28	0,30	0,32	0,34	0,36	70
K2	P	0,26	0,28	0,30	0,32	0,32	60
K3	P	0,26	0,28	0,30	0,32	0,32	50
K4	P	0,26	0,28	0,30	0,32	0,32	49
K5	P	0,24	0,26	0,26	0,28	0,30	29
N2	M	0,26	0,28	0,30	0,32	0,34	140
N3	M	0,26	0,28	0,30	0,32	0,34	95
N11	M	0,26	0,28	0,30	0,32	0,34	110
S1	M	0,095	0,11	0,12	0,13	0,13	22
S2	M	0,095	0,11	0,12	0,13	0,13	16
S3	M	0,095	0,11	0,12	0,13	0,13	16
S11	M	0,16	0,17	0,19	0,20	0,22	42
S12	M	0,16	0,17	0,19	0,20	0,22	32
S13	M	0,14	0,15	0,17	0,18	0,19	25
H3	P	0,12	0,13	0,14	0,15	0,15	21
H5	P	0,19	0,20	0,22	0,22	0,24	39
H7	P	0,12	0,13	0,14	0,15	0,15	21
H8	P	0,14	0,15	0,16	0,17	0,18	39
H11	P	0,19	0,20	0,22	0,22	0,24	49
H12	P	0,14	0,15	0,16	0,17	0,18	26
H21	P	0,14	0,15	0,16	0,17	0,18	39

SMG = Seco material group

f = mm/rev

v_c = m/min

All cutting data are start values

Application information

Machined surface

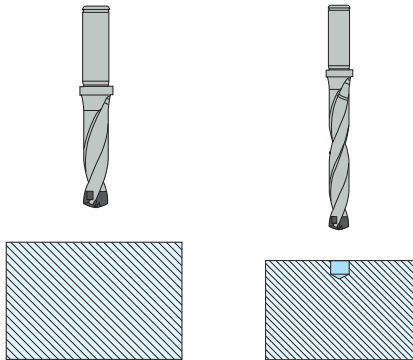

No pre-drilling or entrance feed needed when using SD403 and SD405. When using a SD408 drill body pre-drilling is always recommended. (When using SD405 in stainless steel a pre-drilling operation might be needed).

Stacked material

It is possible to drill stacked material as long as the pieces are securely clamped together, so that there are no air gaps between the parts. Air gaps can affect chip evacuation, and thereby damage the drill.

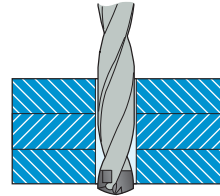

Irregular/Angled hole entrance

Pre-drilling operation alternatives

If irregular or angle entrance use pre operations accordingly.

When using drills >3 x D pre-drilling with a standard tool e.g. SD403 is recommended

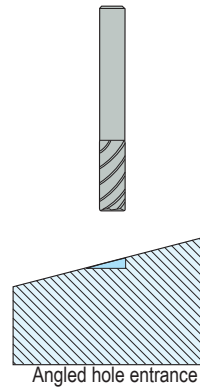
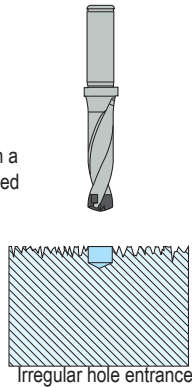

Machine a flat using an end mill from the Seco range.

Coolant recommendations

Coolant pressure

Minimum recommended coolant pressure 10 bar with $\leq 3 \times D$
 Minimum recommended coolant pressure 30 bar with $> 3 \times D$

Coolant mix

Recommended emulsion mix 6-8%. When drilling in stainless steels, superalloys and high strength steels a mix of 10% is recommended

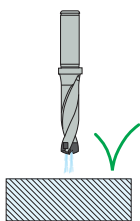

First choice

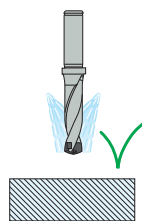

< 3 x D

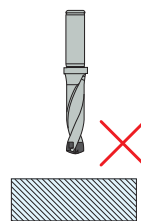

Machining data

The values in the graphs vary with e.g. cutting data, material, efficiency of the machine and tool wear. The graphs below are valid for Seco Material Group (SMG) P5-P6 and cutting speed 90 m/min.

Net power consumption

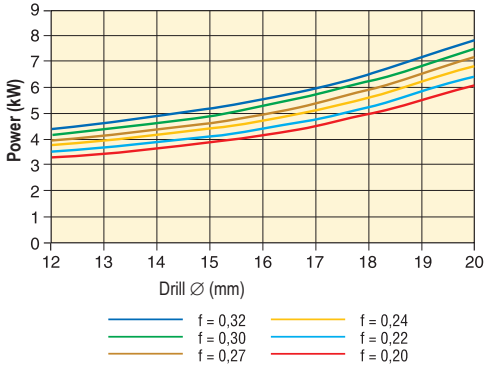

Drilling torque

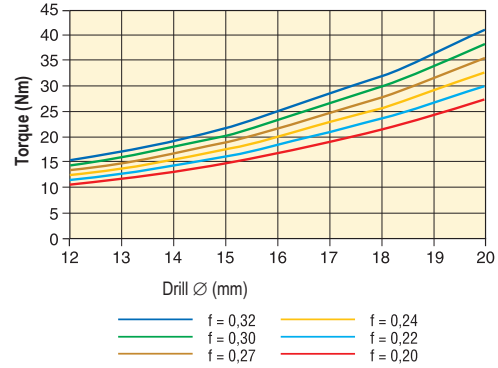

Feed force

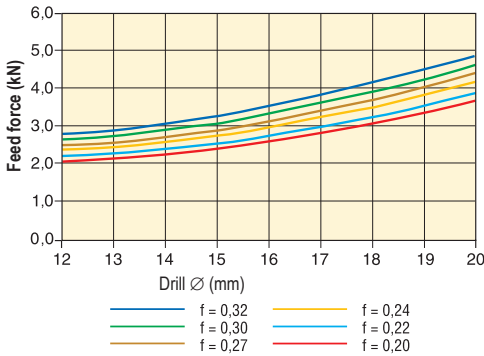

Coolant flow at different pressures

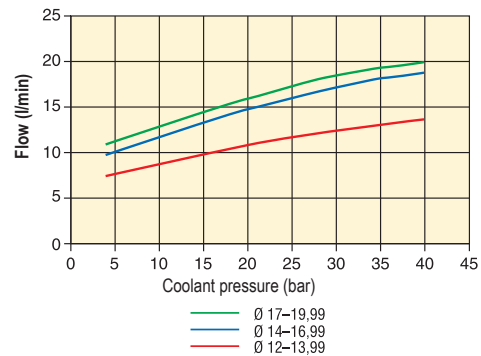

Hole tolerances/Surface finish

SD403, SD405 and SD408 IT9-10 / R _a 1-4*		
Drill Ø DC (mm)	IT9 tolerance (µm)	IT10 tolerance (µm)
10-18	43	70
18-30	52	84

Recommended coolant flow Dx1 l/min

Minimum coolant flow D/2 l/min

D = Drill diameter

Minimum recommended coolant pressure 10 bar with $\leq 3 \times D$

Minimum recommended coolant pressure 20 bar with $\leq 5 \times D$

Minimum recommended coolant pressure 40 bar with $> 5 \times D$

Coolant mix

Recommended emulsion mix is 6-8%.





When drilling in stainless steels, superalloys and high strength steels a mix of 10% is recommended.

*Deterioration of surface finish and hole tolerance can occur when drilling in low carbon steel or stainless steel.

Use the shortest drill possible for best hole quality.

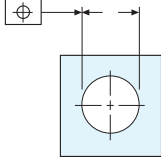
Troubleshooting

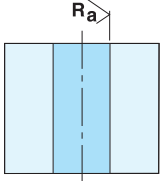
- Fixturing stability
- Machine spindle condition
- Tool holder condition
- Clamping of tool:
 - Run-out within 0.06 TIR
- Chip evacuation:
- Cutting data
- Coolant:
 - Pressure
 - Flow
 - Concentration

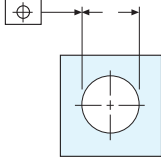
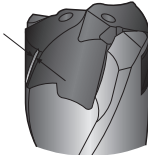
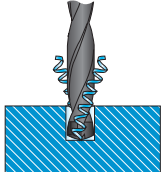
<p>Cutting edges get chipped</p> <ul style="list-style-type: none"> • Reduce the feed/rev • If the drill vibrates, reduce the cutting speed and increase the feed rate • When drilling through rough or hard surfaces, reduce the feed rate by 30%-50% during entrance and exit 	<p>Unsatisfactory diameter tolerance</p> <ul style="list-style-type: none"> • Increase the feed/rev. • Use a Seco Feedmax solid carbide drill, see page(s) 18-21 • Use a reaming operation, see page(s) 231 • Use a boring operation, see page(s) 387-388 
<p>Too fast flank wear</p> <ul style="list-style-type: none"> • Check that the correct geometry is used • Reduce the cutting speed 	<p>Unsatisfactory surface finish</p> <ul style="list-style-type: none"> • Reduce the feed/rev. • Increase the cutting speed. • Check that the correct geometry is used. • Use a Seco Feedmax solid carbide drill, see page(s) 18-21 • Use a reaming operation, see page(s) 231 
<p>Groove wear</p> <ul style="list-style-type: none"> • Reduce the feed/rev • Reduce the cutting speed • Increase the coolant concentration 	<p>Unsatisfactory positioning of the hole</p> <ul style="list-style-type: none"> • Reduce the feed/rev • If drilling through rough, hard and angled surfaces - reduce the feed by 30%-50% during entrance and exit • Pre drill with a 140° point angle • Use a Seco Feedmax solid carbide drill see Feedmax page(s) 18-21 • Use a boring operation, see page(s) 387-388 
<p>Wear of peripheral land margins</p> <ul style="list-style-type: none"> • Check that the correct geometry is used • Reduce the cutting speed • Increase the coolant concentration • When drilling through rough or hard surfaces, reduce the feed rate by 30%-50% during entrance and exit 	<p>Chip jamming due to long chips</p> <ul style="list-style-type: none"> • Increase the feed • In long chipping materials SMGP1-P4, SMGM1-M2: <ul style="list-style-type: none"> - Increase cutting speed and reduce feed/rev - Use the -L geometry 



Indexable insert drill



Range overview

Perfomax®	∅ Range	Drill depth	Drill ∅ tolerance	Hole tolerance
<p>SD522</p>  <p>Page(s) 165-167</p>	15-59 mm	~ 2 x D	+/-0,1	+0/+0,2
<p>SD523</p>  <p>Page(s) 168-174</p>	15-59 mm	~ 3 x D	+/-0,1	+0/+0,3
<p>SD524</p>  <p>Page(s) 175-180</p>	17-59 mm	~ 4 x D	+/- 0,1	+0/+0,4
<p>SD525</p>  <p>Page(s) 181</p>	19-45 mm	~ 5 x D	+/- 0,1	+0/+0,5
<p>SD542</p>  <p>Page(s) 182</p>	60-85 mm	~ 2,5 x D	+/- 0,1	+0/+0,3

Range overview

Perfomax®	∅ Range	Drill depth	Drill ∅ tolerance	Hole tolerance
<p>SD572</p>  <p>Page(s) 183-184</p>	15-47 mm	2 x D	+/- 0,1	+0/+0,2
<p>SD602</p>  <p>Page(s) 189-190</p>	60-160 mm	1 – 10 x D	+/- 0,2	-

Code key - Indexable insert drill – Metric

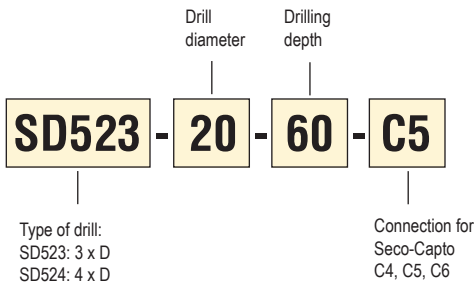
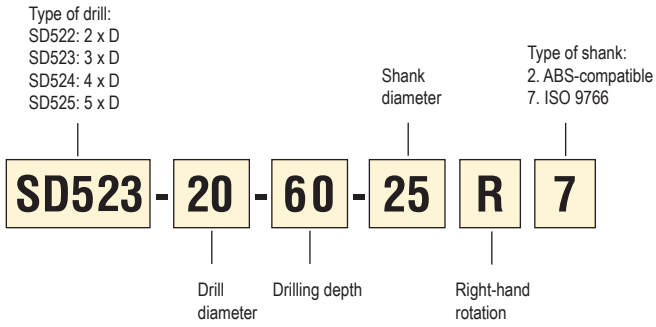

Shanks

ISO 9766

Universal choice fits into most holders on the market such as:

- Weldon 1835B
- ISO 5414
- DIN 69880

Coolant inlet at the back end of the drill.

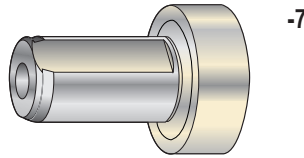

Shank with two flats

Centre insert
cutting edge
above workpiece
centre line

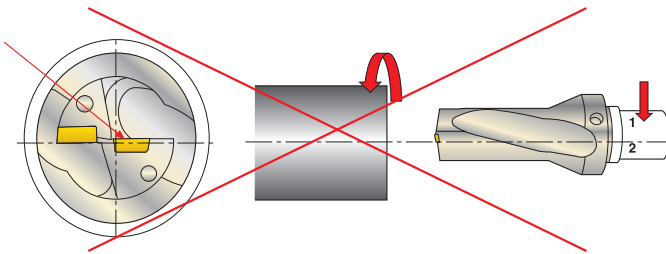

For non rotating applications:

An additional flat is added to the shank for increased flexibility in lathe applications. In such applications the workpiece centre line and the drill centre line must align. If they don't the centre insert could be located above the workpiece centre line resulting in poor performance of the drill.

Centre insert
cutting edge
below workpiece
centre line

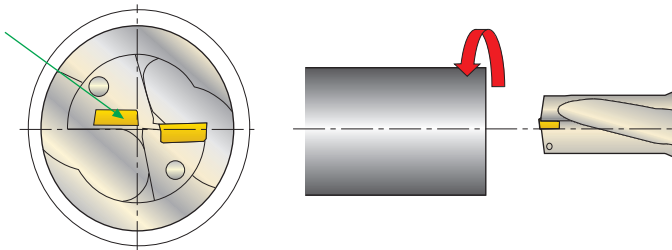

By turning the drill 180 degrees the second flat gives the possibility to compensate for this misalignment in a fast and simple way.

NOTE! If a drill with -7 shank is used in a rotating application together with our adjustable holder, the flat located on the same side as the centre insert must be used. Otherwise the drill diameter will be positioned in the wrong way.

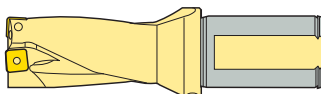

Shanks

Seco-Capto

- Flexible - Same tool holder can easily be used in different machines
- Modular - Possibility to build tools with extension adapters
- High torque transmission - Torque load is spread symmetrically
- High rigidity - Tight press fit guarantees that there is no play in the coupling
- Accurate - Tapered polygon coupling produces a strong, self centering joint within 2 microns

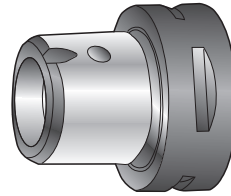

-C
(4, 5, 6)

Graflex

- Fits directly into Graflex holders and locked with two ball headed locking screws placed 120°.
- Short overhang - rigidity and productivity
- Cylinder/face connection - great accuracy
- Coolant inlet at the back end of the drill

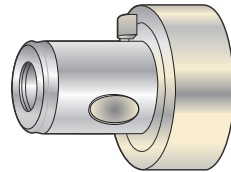

-G

ABS 50

- An ABS 50 Compatible shank
- Fits directly into ABS 50 holder with one locking screw
- Coolant inlet at the back end of the drill

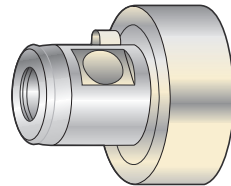

-2

VDI30 and VDI 40

- VDI compatible shank
- Fits directly into holders for
 - VDI 3425 bl.2
 - DIN 69880

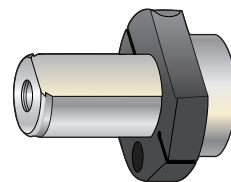



-8

NOTE! The coolant ring must ordered separately

Shanks

Available in:

VDI 30	VDI 40
	
Accessories Coolant ring	Accessories Coolant ring
SDA5-30R8	SDA5-40R8

1. Fit the ring around the drill but do not tighten the locking screw

2. Lock the drill in the collet

3. Tighten the locking screw in the coolant ring

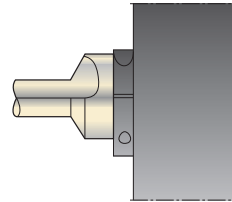
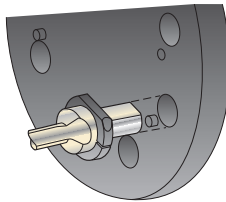
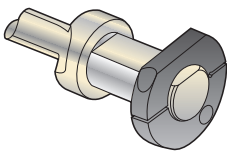

Coolant ring

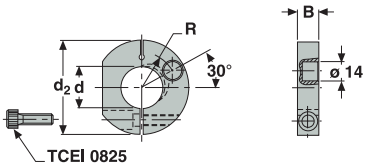

Drilling depth ~ 2 X D – Metric

ISO 9766 shank, -7



- Internal coolant
- For insert information see page(s) 197-200
- For cutting data see page(s) 203-204
- Spare parts and accessories see page(s) 185

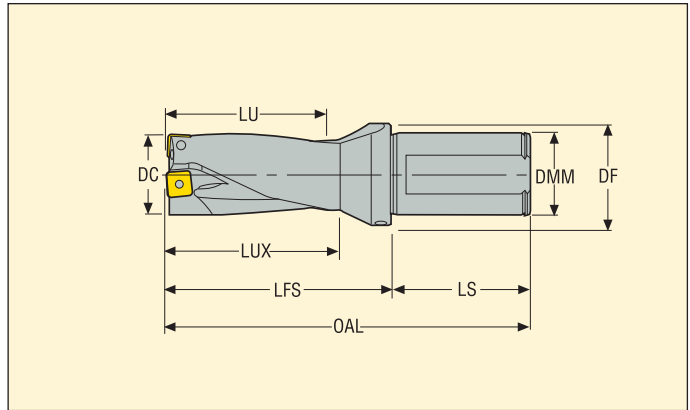

DC (mm)	LU	Ordering and Product No.	Designation	Dimensions in mm						Insert		Radial adjustment	
				OAL	LFS	LS	LUX	DMM	DF	Centre insert	Periph insert	-	+
15,0	30	03080744	SD522-15-30-20R7	110	60	50	35	20	30	SPGX0502	SCGX050204	0,22	0,31
15,0	30	03080745	SD522-15-30-25R7	116	60	56	35	25	35	SPGX0502	SCGX050204	0,22	0,31
15,5	31	03080740	SD522-15.5-31-20R7	111	61	50	36	20	30	SPGX0502	SCGX050204	0,17	0,36
15,5	31	03080741	SD522-15.5-31-25R7	117	61	56	36	25	35	SPGX0502	SCGX050204	0,17	0,36
16,0	32	03080749	SD522-16-32-20R7	112	62	50	37	20	30	SPGX0502	SCGX050204	0,12	0,41
16,0	32	03080750	SD522-16-32-25R7	118	62	56	37	25	35	SPGX0502	SCGX050204	0,12	0,41
16,5	33	03080746	SD522-16.5-33-20R7	113	63	50	38	20	30	SPGX0502	SCGX050204	0,07	0,46
16,5	33	03080747	SD522-16.5-33-25R7	119	63	56	38	25	35	SPGX0502	SCGX050204	0,07	0,46
17,0	34	03080754	SD522-17-34-20R7	114	64	50	39	20	30	SPGX0502	SCGX050204	0,02	0,5
17,0	34	03080755	SD522-17-34-25R7	120	64	56	39	25	35	SPGX0502	SCGX050204	0,02	0,5
17,5	35	03080752	SD522-17.5-35-20R7	115	65	50	40	20	30	SPGX0602	SCGX050204	0,43	0,1
17,5	35	03080753	SD522-17.5-35-25R7	121	65	56	40	25	35	SPGX0602	SCGX050204	0,43	0,1
18,0	36	03080760	SD522-18-36-20R7	116	66	50	41	20	30	SPGX0602	SCGX050204	0,32	0,21
18,0	36	03080761	SD522-18-36-25R7	122	66	56	41	25	35	SPGX0602	SCGX050204	0,32	0,21
18,5	37	03080758	SD522-18.5-37-20R7	117	67	50	42	20	30	SPGX0602	SCGX050204	0,22	0,31
18,5	37	03080759	SD522-18.5-37-25R7	123	67	56	42	25	35	SPGX0602	SCGX050204	0,22	0,31
19,0	38	03080765	SD522-19-38-20R7	118	68	50	43	20	30	SPGX0602	SCGX050204	0,11	0,42
19,0	38	03080766	SD522-19-38-25R7	124	68	56	43	25	35	SPGX0602	SCGX050204	0,11	0,42
19,5	39	03080764	SD522-19.5-39-20R7	119	69	50	44	20	30	SPGX0602	SCGX060204	0,11	0,42
20,0	40	03080771	SD522-20-40-25R7	126	70	56	45	25	35	SPGX0602	SCGX060204	0,07	0,46
21,0	42	03080775	SD522-21-42-25R7	128	72	56	47	25	35	SPGX0602	SCGX060204	0,01	0,5
22,0	44	03080777	SD522-22-44-25R7	130	74	56	49	25	35	SPGX0703	SCGX060204	0,44	0,46
23,0	46	03080781	SD522-23-46-25R7	132	76	56	51	25	35	SPGX0703	SCGX070308	0,33	0,5
23,5	47	03192517	SD522-23.5-47-25R7	133	77	56	52	25	35	SPGX0703	SCGX070308	0,23	0,5
24,0	48	03080785	SD522-24-48-25R7	134	78	56	53	25	35	SPGX0703	SCGX070308	0,11	0,5
25,0	50	03080788	SD522-25-50-32R7	140	80	60	55	32	42	SPGX0703	SCGX070308	0,11	0,5
26,0	52	03080790	SD522-26-52-32R7	142	82	60	57	32	42	SPGX0903	SCGX070308	0,5	0,11
27,0	54	03080792	SD522-27-54-32R7	144	84	60	59	32	42	SPGX0903	SCGX070308	0,5	0,26
28,0	56	03080795	SD522-28-56-32R7	146	86	60	61	32	42	SPGX0903	SCGX070308	0,28	0,5
29,0	58	03080796	SD522-29-58-32R7	148	88	60	63	32	42	SPGX0903	SCGX09T308	0,18	0,5
30,0	60	03080798	SD522-30-60-32R7	150	90	60	65	32	42	SPGX0903	SCGX09T308	0,12	0,5
31,0	62	03080801	SD522-31-62-32R7	152	92	60	67	32	42	SPGX0903	SCGX09T308	0,12	0,5
32,0	64	03080802	SD522-32-64-32R7	154	94	60	69	32	42	SPGX11T3	SCGX09T308	0,5	0,31
32,0	64	03080803	SD522-32-64-40R7	162	94	68	69	40	50	SPGX11T3	SCGX09T308	0,5	0,31
33,0	66	03080805	SD522-33-66-32R7	156	96	60	71	32	42	SPGX11T3	SCGX09T308	0,5	0,46
33,0	66	03080806	SD522-33-66-40R7	164	96	68	71	40	50	SPGX11T3	SCGX09T308	0,5	0,46
34,0	68	03080808	SD522-34-68-32R7	158	98	60	73	32	42	SPGX11T3	SCGX09T308	0,22	0,5
34,0	68	03080809	SD522-34-68-40R7	166	98	68	73	40	50	SPGX11T3	SCGX09T308	0,22	0,5
35,0	70	03080810	SD522-35-70-32R7	160	100	60	75	32	42	SPGX11T3	SCGX11T308	0,22	0,5
35,0	70	03080811	SD522-35-70-40R7	168	100	68	75	40	50	SPGX11T3	SCGX11T308	0,22	0,5
36,0	72	03080813	SD522-36-72-32R7	162	102	60	77	32	42	SPGX11T3	SCGX11T308	0,09	0,5

For intermediate diameters see the MyDesign software.

Drilling depth ~ 2 X D - Metric

ISO 9766 shank, -7

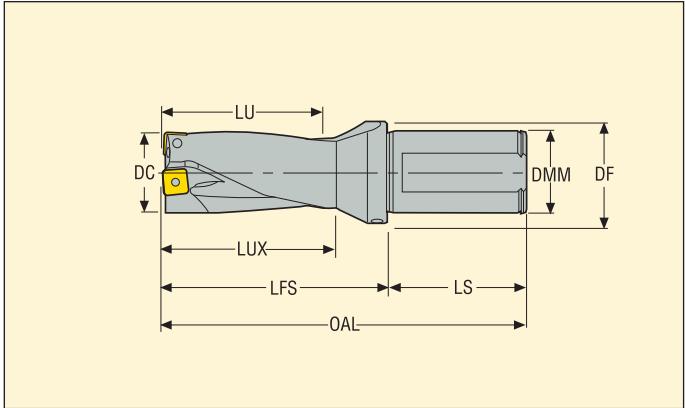

- Internal coolant
- For insert information see page(s) 197-200
- For cutting data see page(s) 203-204
- Spare parts and accessories see page(s) 185

DC (mm)	LU	Ordering and Product No.	Designation	Dimensions in mm						Insert		Radial adjustment	
				OAL	LFS	LS	LUX	DMM	DF	Centre insert	Periph insert	-	+
36,0	72	03080814	SD522-36-72-40R7	170	102	68	77	40	50	SPGX11T3	SCGX11T308	0,09	0,5
37,0	74	03080816	SD522-37-74-32R7	164	104	60	79	32	42	SPGX11T3	SCGX11T308	0,09	0,5
37,0	74	03080817	SD522-37-74-40R7	172	104	68	79	40	50	SPGX11T3	SCGX11T308	0,09	0,5
38,0	76	03080818	SD522-38-76-32R7	166	106	60	81	32	42	SPGX12T3	SCGX11T308	0,5	0,5
38,0	76	03080819	SD522-38-76-40R7	174	106	68	81	40	50	SPGX12T3	SCGX11T308	0,5	0,5
39,0	78	03080821	SD522-39-78-32R7	168	108	60	83	32	42	SPGX12T3	SCGX11T308	0,39	0,5
39,0	78	03080822	SD522-39-78-40R7	176	108	68	83	40	50	SPGX12T3	SCGX11T308	0,39	0,5
40,0	80	03080823	SD522-40-80-32R7	170	110	60	85	32	50	SPGX12T3	SCGX11T308	0,19	0,5
40,0	80	03080824	SD522-40-80-40R7	178	110	68	85	40	50	SPGX12T3	SCGX11T308	0,19	0,5
41,0	82	03080826	SD522-41-82-40R7	180	112	68	87	40	50	SPGX12T3	SCGX120408	0,19	0,5
42,0	84	03080828	SD522-42-84-40R7	182	114	68	89	40	50	SPGX12T3	SCGX120408	0,19	0,5
43,0	86	03080830	SD522-43-86-40R7	184	116	68	91	40	50	SPGX12T3	SCGX120408	0,05	0,5
44,0	88	03080832	SD522-44-88-40R7	186	118	68	93	40	50	SPGX1504	SCGX120408	0,5	0,41
45,0	90	03080834	SD522-45-90-40R7	188	120	68	95	40	50	SPGX1504	SCGX150512	0,5	0,41
46,0	92	03080835	SD522-46-92-40R7	190	122	68	97	40	50	SPGX1504	SCGX150512	0,5	0,5
47,0	94	03080836	SD522-47-94-40R7	192	124	68	99	40	50	SPGX1504	SCGX150512	0,5	0,5
48,0	96	03080837	SD522-48-96-40R7	194	126	68	101	40	59	SPGX1504	SCGX150512	0,45	0,5
49,0	98	03080838	SD522-49-98-40R7	196	128	68	103	40	59	SPGX1504	SCGX150512	0,2	0,5
50,0	100	03080839	SD522-50-100-40R7	198	130	68	105	40	59	SPGX1504	SCGX150512	0,2	0,5
51,0	102	03080840	SD522-51-102-40R7	200	132	68	107	40	59	SPGX1504	SCGX150512	0,2	0,5
52,0	104	03080841	SD522-52-104-40R7	202	134	68	109	40	59	SPGX1904	SCGX150512	0,5	0,42
53,0	106	03080842	SD522-53-106-40R7	204	136	68	111	40	59	SPGX1904	SCGX150512	0,5	0,42
54,0	108	03080843	SD522-54-108-40R7	206	138	68	113	40	59	SPGX1904	SCGX150512	0,5	0,5
55,0	110	03080844	SD522-55-110-40R7	208	140	68	115	40	59	SPGX1904	SCGX150512	0,5	0,5
56,0	112	03080845	SD522-56-112-40R7	210	142	68	117	40	59	SPGX1904	SCGX150512	0,5	0,5
57,0	114	03080846	SD522-57-114-40R7	212	144	68	119	40	59	SPGX1904	SCGX150512	0,39	0,5
58,0	116	03080847	SD522-58-116-40R7	214	146	68	121	40	63	SPGX1904	SCGX150512	0,09	0,5
59,0	118	03080848	SD522-59-118-40R7	216	148	68	123	40	63	SPGX1904	SCGX150512	0,09	0,5

For intermediate diameters see the MyDesign software.

Drilling depth ~ 2 X D – Metric

ABS 50 compatible shank, -2



- Internal coolant
- For insert information see page(s) 197-200
- For cutting data see page(s) 203-204
- Spare parts and accessories see page(s) 185

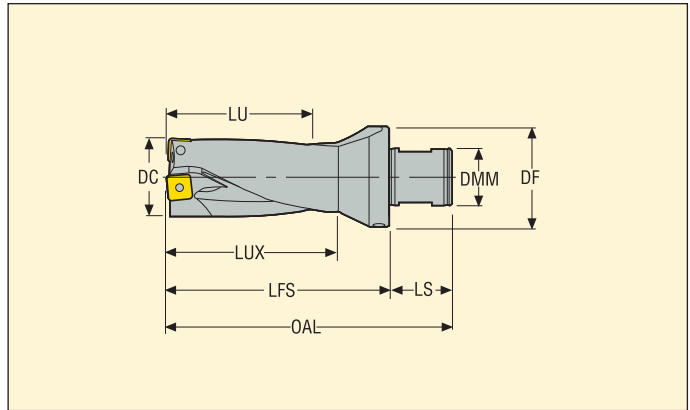

DC (mm)	LU	Ordering and Product No.	Designation	Dimensions in mm						Insert		Radial adjustment	
				OAL	LFS	LS	LUX	DMM	DF	Centre insert	Periph insert	-	+
15,0	30	03081056	SD522-15-30-50R2	91	60	31	35	28	50	SPGX0502	SCGX050204	0,22	0,31
15,5	31	03081057	SD522-15.5-31-50R2	92	61	31	36	28	50	SPGX0502	SCGX050204	0,17	0,36
16,0	32	03080751	SD522-16-32-50R2	93	62	31	37	28	50	SPGX0502	SCGX050204	0,12	0,41
16,5	33	03081058	SD522-16.5-33-50R2	94	63	31	38	28	50	SPGX0502	SCGX050204	0,07	0,46
17,0	34	03081059	SD522-17-34-50R2	95	64	31	39	28	50	SPGX0502	SCGX050204	0,02	0,5
17,5	35	03081060	SD522-17.5-35-50R2	96	65	31	40	28	50	SPGX0602	SCGX050204	0,43	0,1
18,0	36	03080762	SD522-18-36-50R2	97	66	31	41	28	50	SPGX0602	SCGX050204	0,32	0,21
18,5	37	03081061	SD522-18.5-37-50R2	98	67	31	42	28	50	SPGX0602	SCGX050204	0,22	0,31
19,0	38	03080767	SD522-19-38-50R2	99	68	31	43	28	50	SPGX0602	SCGX050204	0,11	0,42
20,0	40	03080772	SD522-20-40-50R2	101	70	31	45	28	50	SPGX0602	SCGX060204	0,07	0,46
20,62	42	03080768	SD522-20.62-42-50R2	103	72	31	47	28	50	SPGX0602	SCGX060204	0,03	0,5
21,0	42	03081062	SD522-21-42-50R2	103	72	31	47	28	50	SPGX0602	SCGX060204	0,01	0,5
22,0	44	03080778	SD522-22-44-50R2	105	74	31	49	28	50	SPGX0703	SCGX060204	0,44	0,46
22,23	45	03080776	SD522-22.23-45-50R2	106	75	31	50	28	50	SPGX0703	SCGX060204	0,39	0,5
23,0	46	03080782	SD522-23-46-50R2	107	76	31	51	28	50	SPGX0703	SCGX070308	0,33	0,5
24,0	48	03080786	SD522-24-48-50R2	109	78	31	53	28	50	SPGX0703	SCGX070308	0,11	0,5
25,0	50	03080789	SD522-25-50-50R2	111	80	31	55	28	50	SPGX0703	SCGX070308	0,11	0,5
25,4	51	03080787	SD522-25.40-51-50R2	112	81	31	56	28	50	SPGX0703	SCGX070308	0,11	0,5
26,0	52	03080791	SD522-26-52-50R2	113	82	31	57	28	50	SPGX0903	SCGX070308	0,5	0,11
27,0	54	03080793	SD522-27-54-50R2	115	84	31	59	28	50	SPGX0903	SCGX070308	0,5	0,26
28,0	56	03081087	SD522-28-56-50R2	117	86	31	61	28	50	SPGX0903	SCGX070308	0,28	0,5
28,59	58	03080794	SD522-28.59-58-50R2	119	88	31	63	28	50	SPGX0903	SCGX09T308	0,21	0,5
29,0	58	03080797	SD522-29-58-50R2	119	88	31	63	28	50	SPGX0903	SCGX09T308	0,18	0,5
30,0	60	03080799	SD522-30-60-50R2	121	90	31	65	28	50	SPGX0903	SCGX09T308	0,12	0,5
31,0	62	03081063	SD522-31-62-50R2	123	92	31	67	28	50	SPGX0903	SCGX09T308	0,12	0,5
31,75	64	03080800	SD522-31.75-64-50R2	125	94	31	69	28	50	SPGX11T3	SCGX09T308	0,5	0,28
32,0	64	03080804	SD522-32-64-50R2	125	94	31	69	28	50	SPGX11T3	SCGX09T308	0,5	0,31
33,0	66	03080807	SD522-33-66-50R2	127	96	31	71	28	50	SPGX11T3	SCGX09T308	0,5	0,46
34,0	68	03081064	SD522-34-68-50R2	129	98	31	73	28	50	SPGX11T3	SCGX09T308	0,22	0,5
35,0	70	03080812	SD522-35-70-50R2	131	100	31	75	28	50	SPGX11T3	SCGX11T308	0,22	0,5
36,0	72	03080815	SD522-36-72-50R2	133	102	31	77	28	50	SPGX11T3	SCGX11T308	0,09	0,5
37,0	74	03081065	SD522-37-74-50R2	135	104	31	79	28	50	SPGX11T3	SCGX11T308	0,09	0,5
38,0	76	03080820	SD522-38-76-50R2	137	106	31	81	28	50	SPGX12T3	SCGX11T308	0,5	0,5
39,0	78	03081066	SD522-39-78-50R2	139	108	31	83	28	50	SPGX12T3	SCGX11T308	0,39	0,5
40,0	80	03080825	SD522-40-80-50R2	141	110	31	85	28	50	SPGX12T3	SCGX11T308	0,19	0,5
41,0	82	03080827	SD522-41-82-50R2	143	112	31	87	28	50	SPGX12T3	SCGX120408	0,19	0,5
42,0	84	03080829	SD522-42-84-50R2	145	114	31	89	28	50	SPGX12T3	SCGX120408	0,19	0,5
43,0	86	03081067	SD522-43-86-50R2	147	116	31	91	28	50	SPGX12T3	SCGX120408	0,05	0,5
44,45	89	03080831	SD522-44.45-89-50R2	150	119	31	94	50	50	SPGX1504	SCGX120408	0,5	0,41

For intermediate diameters see the MyDesign software.

Drilling depth ~ 3 x D – Metric

ISO 9766 shank, -7



- Internal coolant
- For insert information see page(s) 197-200
- For cutting data see page(s) 205-206
- Spare parts and accessories see page(s) 185

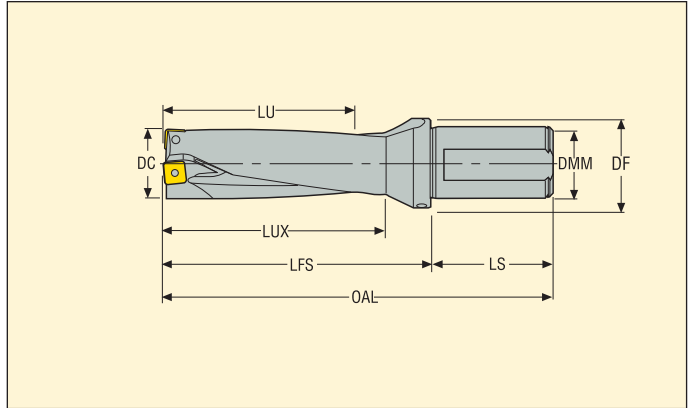

DC (mm)	LU	Ordering and Product No.	Designation	Dimensions in mm						Insert		Radial adjustment	
				OAL	LFS	LS	LUX	DMM	DF	Centre insert	Periph insert	-	+
15,0	45	03080548	SD523-15-45-20R7	125	75	50	50	20	30	SPGX0502	SCGX050204	0,22	0,31
15,0	45	03080549	SD523-15-45-25R7	131	75	56	50	25	35	SPGX0502	SCGX050204	0,22	0,31
15,5	47	03080544	SD523-15.5-47-20R7	127	77	50	52	20	30	SPGX0502	SCGX050204	0,17	0,36
15,5	47	03080545	SD523-15.5-47-25R7	133	77	56	52	25	35	SPGX0502	SCGX050204	0,17	0,36
16,0	48	03080557	SD523-16-48-20R7	128	78	50	53	20	30	SPGX0502	SCGX050204	0,12	0,41
16,0	48	03080558	SD523-16-48-25R7	134	78	56	53	25	35	SPGX0502	SCGX050204	0,12	0,41
16,5	50	03080552	SD523-16.5-50-20R7	130	80	50	55	20	30	SPGX0502	SCGX050204	0,07	0,46
16,5	50	03080554	SD523-16.5-50-25R7	136	80	56	55	25	35	SPGX0502	SCGX050204	0,07	0,46
17,0	51	03080568	SD523-17-51-20R7	131	81	50	56	20	30	SPGX0502	SCGX050204	0,02	0,5
17,0	51	03080569	SD523-17-51-25R7	137	81	56	56	25	35	SPGX0502	SCGX050204	0,02	0,5
17,5	53	03080562	SD523-17.5-53-20R7	133	83	50	58	20	30	SPGX0602	SCGX050204	0,43	0,1
17,5	53	03080563	SD523-17.5-53-25R7	139	83	56	58	25	35	SPGX0602	SCGX050204	0,43	0,1
18,0	54	03080574	SD523-18-54-20R7	134	84	50	59	20	30	SPGX0602	SCGX050204	0,32	0,21
18,0	54	03080575	SD523-18-54-25R7	140	84	56	59	25	35	SPGX0602	SCGX050204	0,32	0,21
18,5	56	03080570	SD523-18.5-56-20R7	136	86	50	61	20	30	SPGX0602	SCGX050204	0,22	0,31
18,5	56	03080571	SD523-18.5-56-25R7	142	86	56	61	25	35	SPGX0602	SCGX050204	0,22	0,31
19,0	57	03080583	SD523-19-57-20R7	137	87	50	62	20	30	SPGX0602	SCGX050204	0,11	0,42
19,0	57	03080584	SD523-19-57-25R7	143	87	56	62	25	35	SPGX0602	SCGX050204	0,11	0,42
19,5	59	03080579	SD523-19.5-59-20R7	139	89	50	64	20	30	SPGX0602	SCGX060204	0,11	0,42
19,5	59	03080580	SD523-19.5-59-25R7	145	89	56	64	25	35	SPGX0602	SCGX060204	0,11	0,42
20,0	60	03080590	SD523-20-60-25R7	146	90	56	65	25	35	SPGX0602	SCGX060204	0,07	0,46
20,5	62	03080586	SD523-20.5-62-25R7	148	92	56	67	25	35	SPGX0602	SCGX060204	0,04	0,49
21,0	63	03080599	SD523-21-63-25R7	149	93	56	68	25	35	SPGX0602	SCGX060204	0,01	0,5
21,5	65	03080595	SD523-21.5-65-25R7	151	95	56	70	25	35	SPGX0703	SCGX060204	0,5	0,36
22,0	66	03080605	SD523-22-66-25R7	152	96	56	71	25	35	SPGX0703	SCGX060204	0,44	0,46
22,5	68	03080602	SD523-22.5-68-25R7	154	98	56	73	25	35	SPGX0703	SCGX070308	0,42	0,47
23,0	69	03080608	SD523-23-69-25R7	155	99	56	74	25	35	SPGX0703	SCGX070308	0,33	0,5
23,5	71	03080607	SD523-23.5-71-25R7	157	101	56	76	25	35	SPGX0703	SCGX070308	0,23	0,5
24,0	72	03080612	SD523-24-72-25R7	158	102	56	77	25	35	SPGX0703	SCGX070308	0,11	0,5
24,5	74	03080611	SD523-24.5-74-25R7	160	104	56	79	25	35	SPGX0703	SCGX070308	0,11	0,5
25,0	75	03080616	SD523-25-75-32R7	165	105	60	80	32	42	SPGX0703	SCGX070308	0,11	0,5
25,5	77	03080615	SD523-25.5-77-32R7	167	107	60	82	32	42	SPGX0903	SCGX070308	0,5	0,11
26,0	78	03080619	SD523-26-78-32R7	168	108	60	83	32	42	SPGX0903	SCGX070308	0,5	0,11
26,5	80	03080618	SD523-26.5-80-32R7	170	110	60	85	32	42	SPGX0903	SCGX070308	0,5	0,19
27,0	81	03080622	SD523-27-81-32R7	171	111	60	86	32	42	SPGX0903	SCGX070308	0,5	0,26
27,5	83	03080621	SD523-27.5-83-32R7	173	113	60	88	32	42	SPGX0903	SCGX070308	0,46	0,44
28,0	84	03080626	SD523-28-84-32R7	174	114	60	89	32	42	SPGX0903	SCGX070308	0,28	0,5
28,5	86	03080624	SD523-28.5-86-32R7	176	116	60	91	32	42	SPGX0903	SCGX09T308	0,21	0,5
29,0	87	03080629	SD523-29-87-32R7	177	117	60	92	32	42	SPGX0903	SCGX09T308	0,18	0,5
29,5	89	03080628	SD523-29.5-89-32R7	179	119	60	94	32	42	SPGX0903	SCGX09T308	0,15	0,5
30,0	90	03080632	SD523-30-90-32R7	180	120	60	95	32	42	SPGX0903	SCGX09T308	0,12	0,5

For intermediate diameters see the MyDesign software.

Drilling depth ~ 3 x D – Metric

ISO 9766 shank, -7



- Internal coolant
- For insert information see page(s) 197-200
- For cutting data see page(s) 205-206
- Spare parts and accessories see page(s) 185

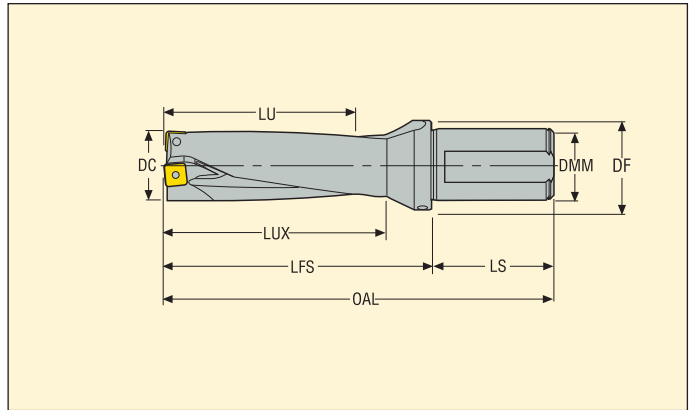

DC (mm)	LU	Ordering and Product No.	Designation	Dimensions in mm						Insert		Radial adjustment	
				OAL	LFS	LS	LUX	DMM	DF	Centre insert	Periph insert	-	+
30,5	92	03080631	SD523-30.5-92-32R7	182	122	60	97	32	42	SPGX0903	SCGX09T308	0,12	0,5
31,0	93	03080636	SD523-31-93-32R7	183	123	60	98	32	42	SPGX0903	SCGX09T308	0,12	0,5
31,5	95	03080634	SD523-31.5-95-32R7	185	125	60	100	32	42	SPGX11T3	SCGX09T308	0,5	0,24
32,0	96	03080638	SD523-32-96-32R7	186	126	60	101	32	42	SPGX11T3	SCGX09T308	0,5	0,31
32,0	96	03080639	SD523-32-96-40R7	194	126	68	101	40	50	SPGX11T3	SCGX09T308	0,5	0,31
33,0	99	03080641	SD523-33-99-32R7	189	129	60	104	32	42	SPGX11T3	SCGX09T308	0,5	0,46
33,0	99	03080642	SD523-33-99-40R7	197	129	68	104	40	50	SPGX11T3	SCGX09T308	0,5	0,46
34,0	102	03080644	SD523-34-102-32R7	192	132	60	107	32	42	SPGX11T3	SCGX09T308	0,22	0,5
34,0	102	03080645	SD523-34-102-40R7	200	132	68	107	40	50	SPGX11T3	SCGX09T308	0,22	0,5
35,0	105	03080648	SD523-35-105-32R7	195	135	60	110	32	42	SPGX11T3	SCGX11T308	0,22	0,5
35,0	105	03080649	SD523-35-105-40R7	203	135	68	110	40	50	SPGX11T3	SCGX11T308	0,22	0,5
35,5	107	03080647	SD523-35.5-107-40R7	205	137	68	112	40	50	SPGX11T3	SCGX11T308	0,09	0,5
36,0	108	03080651	SD523-36-108-32R7	198	138	60	113	32	42	SPGX11T3	SCGX11T308	0,09	0,5
36,0	108	03080652	SD523-36-108-40R7	206	138	68	113	40	50	SPGX11T3	SCGX11T308	0,09	0,5
37,0	111	03080653	SD523-37-111-32R7	201	141	60	116	32	42	SPGX11T3	SCGX11T308	0,09	0,5
37,0	111	03080654	SD523-37-111-40R7	209	141	68	116	40	50	SPGX11T3	SCGX11T308	0,09	0,5
38,0	114	03080655	SD523-38-114-32R7	204	144	60	119	32	42	SPGX12T3	SCGX11T308	0,5	0,5
38,0	114	03080656	SD523-38-114-40R7	212	144	68	119	40	50	SPGX12T3	SCGX11T308	0,5	0,5
39,0	117	03080658	SD523-39-117-32R7	207	147	60	122	32	42	SPGX12T3	SCGX11T308	0,39	0,5
39,0	117	03080659	SD523-39-117-40R7	215	147	68	122	40	50	SPGX12T3	SCGX11T308	0,39	0,5
40,0	120	03080661	SD523-40-120-32R7	210	150	60	125	32	50	SPGX12T3	SCGX11T308	0,19	0,5
40,0	120	03080662	SD523-40-120-40R7	218	150	68	125	40	50	SPGX12T3	SCGX11T308	0,19	0,5
41,0	123	03080665	SD523-41-123-40R7	221	153	68	128	40	50	SPGX12T3	SCGX120408	0,19	0,5
41,5	125	03080663	SD523-41.5-125-40R7	223	155	68	130	40	50	SPGX12T3	SCGX120408	0,19	0,5
42,0	126	03080666	SD523-42-126-40R7	224	156	68	131	40	50	SPGX12T3	SCGX120408	0,19	0,5
43,0	129	03080667	SD523-43-129-40R7	227	159	68	134	40	50	SPGX12T3	SCGX120408	0,05	0,5
44,0	132	03080670	SD523-44-132-40R7	230	162	68	137	40	50	SPGX1504	SCGX120408	0,5	0,41
44,5	134	03080669	SD523-44.5-134-40R7	232	164	68	139	40	50	SPGX1504	SCGX150512	0,5	0,41
45,0	135	03080672	SD523-45-135-40R7	233	165	68	140	40	50	SPGX1504	SCGX150512	0,5	0,41
46,0	138	03080673	SD523-46-138-40R7	236	168	68	143	40	50	SPGX1504	SCGX150512	0,5	0,5
47,0	141	03080675	SD523-47-141-40R7	239	171	68	146	40	50	SPGX1504	SCGX150512	0,5	0,5
47,5	143	03080674	SD523-47.5-143-40R7	241	173	68	148	40	50	SPGX1504	SCGX150512	0,5	0,5
48,0	144	03080676	SD523-48-144-40R7	242	174	68	149	40	59	SPGX1504	SCGX150512	0,45	0,5
49,0	147	03080677	SD523-49-147-40R7	245	177	68	152	40	59	SPGX1504	SCGX150512	0,2	0,5
50,0	150	03080678	SD523-50-150-40R7	248	180	68	155	40	59	SPGX1504	SCGX150512	0,2	0,5
51,0	153	03080679	SD523-51-153-40R7	251	183	68	158	40	59	SPGX1504	SCGX150512	0,2	0,5
52,0	156	03080680	SD523-52-156-40R7	254	186	68	161	40	59	SPGX1904	SCGX150512	0,5	0,42
53,0	159	03080681	SD523-53-159-40R7	257	189	68	164	40	59	SPGX1904	SCGX150512	0,5	0,42
54,0	162	03080682	SD523-54-162-40R7	260	192	68	167	40	59	SPGX1904	SCGX150512	0,5	0,5
55,0	165	03080683	SD523-55-165-40R7	263	195	68	170	40	59	SPGX1904	SCGX150512	0,5	0,5
56,0	168	03080684	SD523-56-168-40R7	266	198	68	173	40	59	SPGX1904	SCGX150512	0,5	0,5

For intermediate diameters see the MyDesign software.

Drilling depth ~ 3 x D – Metric

ISO 9766 shank, -7

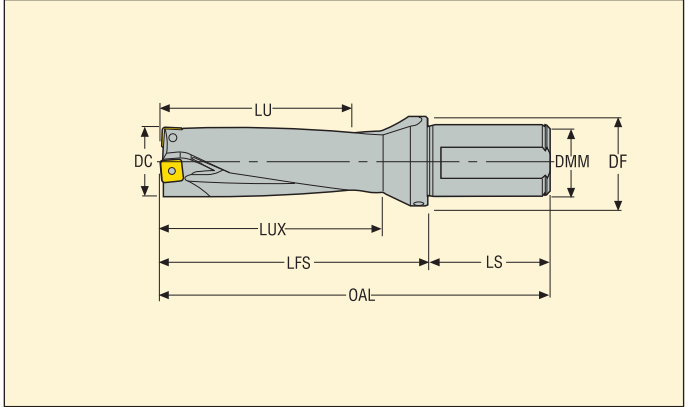

- Internal coolant
- For insert information see page(s) 197-200
- For cutting data see page(s) 205-206
- Spare parts and accessories see page(s) 185

DC (mm)	LU	Ordering and Product No.	Designation	Dimensions in mm						Insert		Radial adjustment	
				OAL	LFS	LS	LUX	DMM	DF	Centre insert	Periph insert	-	+
57.0	171	03080685	SD523-57-171-40R7	269	201	68	176	40	59	SPGX1904	SCGX150512	0,39	0,5
58.0	174	03080686	SD523-58-174-40R7	272	204	68	179	40	63	SPGX1904	SCGX150512	0,09	0,5
59.0	177	03080687	SD523-59-177-40R7	275	207	68	182	40	63	SPGX1904	SCGX150512	0,09	0,5

For intermediate diameters see the MyDesign software.

Drilling depth ~ 3 x D – Metric

ABS 50 compatible shank, -2



- Internal coolant
- For insert information see page(s) 197-200
- For cutting data see page(s) 205-206
- Spare parts and accessories see page(s) 185

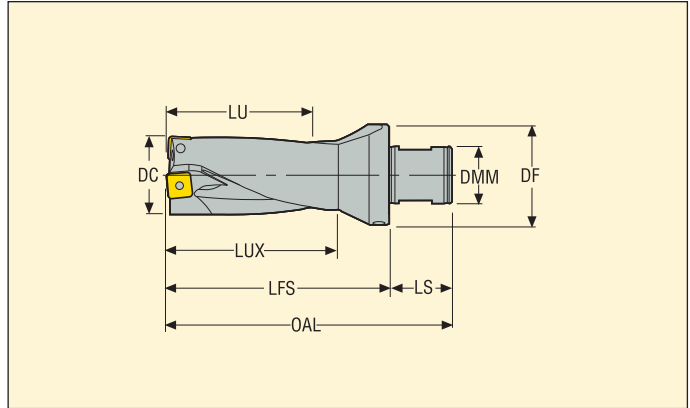

DC (mm)	LU	Ordering and Product No.	Designation	Dimensions in mm						Insert		Radial adjustment	
				OAL	LFS	LS	LUX	DMM	DF	Centre insert	Periph insert	-	+
15,0	45	03080864	SD523-15-45-50R2	106	75	31	50	28	50	SPGX0502	SCGX050204	0,22	0,31
15,5	47	03080865	SD523-15.5-47-50R2	108	77	31	52	28	50	SPGX0502	SCGX050204	0,17	0,36
16,0	48	03080559	SD523-16-48-50R2	109	78	31	53	28	50	SPGX0502	SCGX050204	0,12	0,41
16,5	50	03080866	SD523-16.5-50-50R2	111	80	31	55	28	50	SPGX0502	SCGX050204	0,07	0,46
17,0	51	03080867	SD523-17-51-50R2	112	81	31	56	28	50	SPGX0502	SCGX050204	0,02	0,5
17,5	53	03080564	SD523-17.5-53-50R2	114	83	31	58	28	50	SPGX0602	SCGX050204	0,43	0,1
18,0	54	03080576	SD523-18-54-50R2	115	84	31	59	28	50	SPGX0602	SCGX050204	0,32	0,21
18,5	56	03080868	SD523-18.5-56-50R2	117	86	31	61	28	50	SPGX0602	SCGX050204	0,22	0,31
19,0	57	03080585	SD523-19-57-50R2	118	87	31	62	28	50	SPGX0602	SCGX050204	0,11	0,42
20,0	60	03080591	SD523-20-60-50R2	121	90	31	65	28	50	SPGX0602	SCGX060204	0,07	0,46
20,62	62	03080587	SD523-20.62-62-50R2	123	92	31	67	28	50	SPGX0602	SCGX060204	0,03	0,5
21,0	63	03080600	SD523-21-63-50R2	124	93	31	68	28	50	SPGX0602	SCGX060204	0,01	0,5
22,0	66	03080606	SD523-22-66-50R2	127	96	31	71	28	50	SPGX0703	SCGX060204	0,44	0,46
22,23	67	03080601	SD523-22.23-67-50R2	128	97	31	72	28	50	SPGX0703	SCGX060204	0,39	0,5
23,0	69	03080869	SD523-23-69-50R2	130	99	31	74	28	50	SPGX0703	SCGX070308	0,33	0,5
24,0	72	03080613	SD523-24-72-50R2	133	102	31	77	28	50	SPGX0703	SCGX070308	0,11	0,5
25,0	75	03080617	SD523-25-75-50R2	136	105	31	80	28	50	SPGX0703	SCGX070308	0,11	0,5
25,4	77	03080614	SD523-25.4-77-50R2	138	107	31	82	28	50	SPGX0703	SCGX070308	0,11	0,5
26,0	78	03080620	SD523-26-78-50R2	139	108	31	83	28	50	SPGX0903	SCGX070308	0,5	0,11
27,0	81	03080623	SD523-27-81-50R2	142	111	31	86	28	50	SPGX0903	SCGX070308	0,5	0,26
28,0	84	03080627	SD523-28-84-50R2	145	114	31	89	28	50	SPGX0903	SCGX070308	0,28	0,5
28,59	86	03080625	SD523-28.59-86-50R2	147	116	31	91	28	50	SPGX0903	SCGX09T308	0,21	0,5
29,0	87	03080630	SD523-29-87-50R2	148	117	31	92	28	50	SPGX0903	SCGX09T308	0,18	0,5
30,0	90	03080633	SD523-30-90-50R2	151	120	31	95	28	50	SPGX0903	SCGX09T308	0,12	0,5
31,0	93	03080637	SD523-31-93-50R2	154	123	31	98	28	50	SPGX0903	SCGX09T308	0,12	0,5
31,75	96	03080635	SD523-31.75-96-50R2	157	126	31	101	28	50	SPGX11T3	SCGX09T308	0,5	0,28
32,0	96	03080640	SD523-32-96-50R2	157	126	31	101	28	50	SPGX11T3	SCGX09T308	0,5	0,31
33,0	99	03080643	SD523-33-99-50R2	160	129	31	104	28	50	SPGX11T3	SCGX09T308	0,5	0,46
34,0	102	03080646	SD523-34-102-50R2	163	132	31	107	28	50	SPGX11T3	SCGX09T308	0,22	0,5
35,0	105	03080650	SD523-35-105-50R2	166	135	31	110	28	50	SPGX11T3	SCGX11T308	0,22	0,5
36,0	108	03080870	SD523-36-108-50R2	169	138	31	113	28	50	SPGX11T3	SCGX11T308	0,09	0,5
37,0	111	03080871	SD523-37-111-50R2	172	141	31	116	28	50	SPGX11T3	SCGX11T308	0,09	0,5
38,0	114	03080657	SD523-38-114-50R2	175	144	31	119	28	50	SPGX12T3	SCGX11T308	0,5	0,5
39,0	117	03080660	SD523-39-117-50R2	178	147	31	122	28	50	SPGX12T3	SCGX11T308	0,39	0,5
40,0	120	03080872	SD523-40-120-50R2	181	150	31	125	28	50	SPGX12T3	SCGX11T308	0,19	0,5
41,0	123	03080873	SD523-41-123-50R2	184	153	31	128	28	50	SPGX12T3	SCGX120408	0,19	0,5
42,0	126	03080874	SD523-42-126-50R2	187	156	31	131	28	50	SPGX12T3	SCGX120408	0,19	0,5
43,0	129	03080875	SD523-43-129-50R2	190	159	31	134	28	50	SPGX12T3	SCGX120408	0,05	0,5
44,0	132	03080671	SD523-44-132-50R2	193	162	31	137	28	50	SPGX1504	SCGX120408	0,5	0,41
44,45	134	03080668	SD523-44.45-134-50R2	195	164	31	139	28	50	SPGX1504	SCGX120408	0,5	0,41

For intermediate diameters see the MyDesign software.

Drilling depth ~ 3 x D – Metric

Seco-Capto™ C4 shank



- Internal coolant
- For insert information see page(s) 197-200
- For cutting data see page(s) 205-206
- Spare parts and accessories see page(s) 185

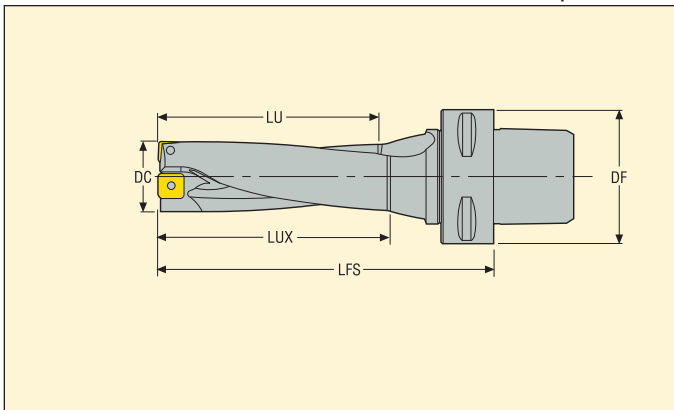

DC (mm)	LU	Ordering and Product No.	Designation	Dimensions in mm			Insert		Radial adjustment	
				LUX	LFS	DF	Centre insert	Periph insert	-	+
15,0	45	03080920	SD523-15-45-C4	50	82	40	SPGX0502	SCGX050204	0,22	0,31
15,5	47	03080921	SD523-15.5-47-C4	52	84	40	SPGX0502	SCGX050204	0,17	0,36
16,0	48	03080922	SD523-16-48-C4	53	86	40	SPGX0502	SCGX050204	0,12	0,41
16,5	50	03080923	SD523-16.5-50-C4	55	88	40	SPGX0502	SCGX050204	0,07	0,46
17,0	51	03080925	SD523-17-51-C4	56	89	40	SPGX0502	SCGX050204	0,02	0,5
17,5	53	03080926	SD523-17.5-53-C4	58	92	40	SPGX0602	SCGX050204	0,43	0,1
18,0	54	03080927	SD523-18-54-C4	59	93	40	SPGX0602	SCGX050204	0,32	0,21
18,5	56	03080928	SD523-18.5-56-C4	61	95	40	SPGX0602	SCGX050204	0,22	0,31
19,0	57	03080929	SD523-19-57-C4	62	96	40	SPGX0602	SCGX050204	0,11	0,42
20,0	60	03080930	SD523-20-60-C4	65	101	40	SPGX0602	SCGX060204	0,07	0,46
20,62	62	03081006	SD523-20.62-62-C4	67	103	40	SPGX0602	SCGX060204	0,03	0,5
21,0	63	03080931	SD523-21-63-C4	68	104	40	SPGX0602	SCGX060204	0,01	0,5
22,0	66	03080932	SD523-22-66-C4	71	107	40	SPGX0703	SCGX060204	0,44	0,46
22,23	67	03081008	SD523-22.23-67-C4	72	108	40	SPGX0703	SCGX060204	0,39	0,5
23,0	69	03080933	SD523-23-69-C4	74	111	40	SPGX0703	SCGX070308	0,33	0,5
24,0	72	03080934	SD523-24-72-C4	77	115	40	SPGX0703	SCGX070308	0,11	0,5
25,0	75	03080935	SD523-25-75-C4	80	119	40	SPGX0703	SCGX070308	0,11	0,5
25,4	77	03081009	SD523-25.4-77-C4	82	121	40	SPGX0703	SCGX070308	0,11	0,5
26,0	78	03080936	SD523-26-78-C4	83	122	40	SPGX0903	SCGX070308	0,5	0,11
27,0	81	03080937	SD523-27-81-C4	86	125	40	SPGX0903	SCGX070308	0,5	0,26
28,0	84	03080938	SD523-28-84-C4	89	129	40	SPGX0903	SCGX070308	0,28	0,5
28,59	86	03081010	SD523-28.59-86-C4	91	131	40	SPGX0903	SCGX09T308	0,21	0,5
29,0	87	03080939	SD523-29-87-C4	92	132	40	SPGX0903	SCGX09T308	0,18	0,5
30,0	90	03080940	SD523-30-90-C4	95	135	40	SPGX0903	SCGX09T308	0,12	0,5

For intermediate diameters see the MyDesign software.

Drilling depth ~ 3 x D – Metric

Seco-Capto™ C5 shank

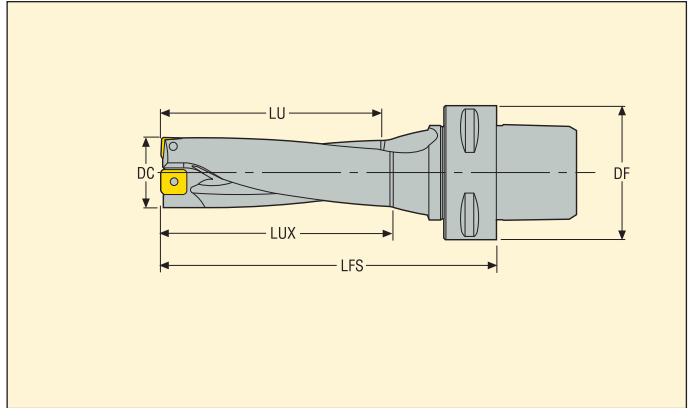

- Internal coolant
- For insert information see page(s) 197-200
- For cutting data see page(s) 205-206
- Spare parts and accessories see page(s) 185

DC (mm)	LU	Ordering and Product No.	Designation	Dimensions in mm			Insert		Radial adjustment	
				LUX	LFS	DF	Centre insert	Periph insert	-	+
15,0	45	03080941	SD523-15-45-C5	50	82	50	SPGX0502	SCGX050204	0,22	0,31
15,5	47	03080942	SD523-15.5-47-C5	52	84	50	SPGX0502	SCGX050204	0,17	0,36
16,0	48	03080943	SD523-16-48-C5	53	86	50	SPGX0502	SCGX050204	0,12	0,41
16,5	50	03080944	SD523-16.5-50-C5	55	88	50	SPGX0502	SCGX050204	0,07	0,46
17,0	51	03080945	SD523-17-51-C5	56	89	50	SPGX0502	SCGX050204	0,02	0,5
17,5	53	03080946	SD523-17.5-53-C5	58	92	50	SPGX0602	SCGX050204	0,43	0,1
18,0	54	03080947	SD523-18-54-C5	59	93	50	SPGX0602	SCGX050204	0,32	0,21
18,5	56	03080948	SD523-18.5-56-C5	61	95	50	SPGX0602	SCGX050204	0,22	0,31
19,0	57	03080949	SD523-19-57-C5	62	96	50	SPGX0602	SCGX050204	0,11	0,42
20,0	60	03080950	SD523-20-60-C5	65	101	50	SPGX0602	SCGX060204	0,07	0,46
20,62	62	03081001	SD523-20.62-62-C5	67	103	50	SPGX0602	SCGX060204	0,03	0,5
21,0	63	03080951	SD523-21-63-C5	68	104	50	SPGX0602	SCGX060204	0,01	0,5
22,0	66	03080952	SD523-22-66-C5	71	107	50	SPGX0703	SCGX060204	0,44	0,46
22,23	67	03081002	SD523-22.23-67-C5	72	108	50	SPGX0703	SCGX060204	0,39	0,5
23,0	69	03080953	SD523-23-69-C5	74	111	50	SPGX0703	SCGX070308	0,33	0,5
24,0	72	03080954	SD523-24-72-C5	77	115	50	SPGX0703	SCGX070308	0,11	0,5
25,0	75	03080955	SD523-25-75-C5	80	119	50	SPGX0703	SCGX070308	0,11	0,5
25,4	77	03081003	SD523-25.4-77-C5	82	121	50	SPGX0703	SCGX070308	0,11	0,5
26,0	78	03080956	SD523-26-78-C5	83	122	50	SPGX0903	SCGX070308	0,5	0,11
27,0	81	03080957	SD523-27-81-C5	86	125	50	SPGX0903	SCGX070308	0,5	0,26
28,0	84	03080958	SD523-28-84-C5	89	129	50	SPGX0903	SCGX070308	0,28	0,5
28,59	86	03081004	SD523-28.59-86-C5	91	131	50	SPGX0903	SCGX09T308	0,21	0,5
29,0	87	03080959	SD523-29-87-C5	92	132	50	SPGX0903	SCGX09T308	0,18	0,5
30,0	90	03080960	SD523-30-90-C5	95	135	50	SPGX0903	SCGX09T308	0,12	0,5
31,0	93	03080961	SD523-31-93-C5	98	138	50	SPGX0903	SCGX09T308	0,12	0,5
31,75	96	03081005	SD523-31.75-96-C5	101	142	50	SPGX11T3	SCGX09T308	0,5	0,28
32,0	96	03080962	SD523-32-96-C5	101	142	50	SPGX11T3	SCGX09T308	0,5	0,31
33,0	99	03080963	SD523-33-99-C5	104	145	50	SPGX11T3	SCGX09T308	0,5	0,46
34,0	102	03080964	SD523-34-102-C5	107	148	50	SPGX11T3	SCGX09T308	0,22	0,5
35,0	105	03080965	SD523-35-105-C5	110	151	50	SPGX11T3	SCGX11T308	0,22	0,5
36,0	108	03080966	SD523-36-108-C5	113	154	50	SPGX11T3	SCGX11T308	0,09	0,5
37,0	111	03080967	SD523-37-111-C5	116	157	50	SPGX11T3	SCGX11T308	0,09	0,5
38,0	114	03080968	SD523-38-114-C5	119	160	50	SPGX12T3	SCGX11T308	0,5	0,5
39,0	117	03080969	SD523-39-117-C5	122	163	50	SPGX12T3	SCGX11T308	0,39	0,5
40,0	120	03080970	SD523-40-120-C5	125	166	50	SPGX12T3	SCGX11T308	0,19	0,5

For intermediate diameters see the MyDesign software.

Drilling depth ~ 3 x D – Metric

Seco-Capto™ C6 shank

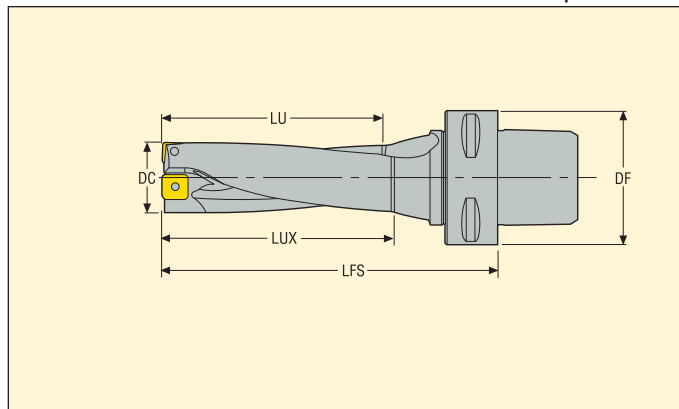

- Internal coolant
- For insert information see page(s) 197-200
- For cutting data see page(s) 205-206
- Spare parts and accessories see page(s) 185

DC (mm)	LU	Ordering and Product No.	Designation	Dimensions in mm			Insert		Radial adjustment	
				LUX	LFS	DF	Centre insert	Periph insert	-	+
15,0	45	03080971	SD523-15-45-C6	50	84	63	SPGX0502	SCGX050204	0,22	0,31
15,5	47	03080972	SD523-15.5-47-C6	52	86	63	SPGX0502	SCGX050204	0,17	0,36
16,0	48	03080973	SD523-16-48-C6	53	88	63	SPGX0502	SCGX050204	0,12	0,41
16,5	50	03080974	SD523-16.5-50-C6	55	90	63	SPGX0502	SCGX050204	0,07	0,46
17,0	51	03080975	SD523-17-51-C6	56	91	63	SPGX0502	SCGX050204	0,02	0,5
17,5	53	03080976	SD523-17.5-53-C6	58	94	63	SPGX0602	SCGX050204	0,43	0,1
18,0	54	03080977	SD523-18-54-C6	59	95	63	SPGX0602	SCGX050204	0,32	0,21
18,5	56	03080978	SD523-18.5-56-C6	61	97	63	SPGX0602	SCGX050204	0,22	0,31
19,0	57	03080979	SD523-19-57-C6	62	98	63	SPGX0602	SCGX050204	0,11	0,42
20,0	60	03080980	SD523-20-60-C6	65	103	63	SPGX0602	SCGX060204	0,07	0,46
20,62	62	03081011	SD523-20.62-62-C6	67	105	63	SPGX0602	SCGX060204	0,03	0,5
21,0	63	03080981	SD523-21-63-C6	68	106	63	SPGX0602	SCGX060204	0,01	0,5
22,0	66	03080982	SD523-22-66-C6	71	109	63	SPGX0703	SCGX060204	0,44	0,46
22,23	67	03081012	SD523-22.23-67-C6	72	110	63	SPGX0703	SCGX060204	0,39	0,5
23,0	69	03080983	SD523-23-69-C6	74	113	63	SPGX0703	SCGX070308	0,33	0,5
24,0	72	03080984	SD523-24-72-C6	77	117	63	SPGX0703	SCGX070308	0,11	0,5
25,0	75	03080985	SD523-25-75-C6	80	121	63	SPGX0703	SCGX070308	0,11	0,5
25,4	77	03081013	SD523-25.4-77-C6	82	123	63	SPGX0703	SCGX070308	0,11	0,5
26,0	78	03080986	SD523-26-78-C6	83	124	63	SPGX0903	SCGX070308	0,5	0,11
27,0	81	03080987	SD523-27-81-C6	86	127	63	SPGX0903	SCGX070308	0,5	0,26
28,0	84	03080988	SD523-28-84-C6	89	131	63	SPGX0903	SCGX070308	0,28	0,5
28,59	86	03081014	SD523-28.59-86-C6	91	133	63	SPGX0903	SCGX09T308	0,21	0,5
29,0	87	03080989	SD523-29-87-C6	92	134	63	SPGX0903	SCGX09T308	0,18	0,5
30,0	90	03080990	SD523-30-90-C6	95	137	63	SPGX0903	SCGX09T308	0,12	0,5
31,0	93	03080991	SD523-31-93-C6	98	140	63	SPGX0903	SCGX09T308	0,12	0,5
31,75	96	03081015	SD523-31.75-96-C6	101	144	63	SPGX11T3	SCGX09T308	0,5	0,28
32,0	96	03080992	SD523-32-96-C6	101	144	63	SPGX11T3	SCGX09T308	0,5	0,31
33,0	99	03080993	SD523-33-99-C6	104	147	63	SPGX11T3	SCGX09T308	0,5	0,46
34,0	102	03080994	SD523-34-102-C6	107	150	63	SPGX11T3	SCGX09T308	0,22	0,5
35,0	105	03080995	SD523-35-105-C6	110	153	63	SPGX11T3	SCGX11T308	0,22	0,5
36,0	108	03080996	SD523-36-108-C6	113	156	63	SPGX11T3	SCGX11T308	0,09	0,5
37,0	111	03080997	SD523-37-111-C6	116	159	63	SPGX11T3	SCGX11T308	0,09	0,5
38,0	114	03080998	SD523-38-114-C6	119	162	63	SPGX12T3	SCGX11T308	0,5	0,5
39,0	117	03080999	SD523-39-117-C6	122	165	63	SPGX12T3	SCGX11T308	0,39	0,5
40,0	120	03081000	SD523-40-120-C6	125	168	63	SPGX12T3	SCGX11T308	0,19	0,5

For intermediate diameters see the MyDesign software.

Drilling depth ~ 4 x D – Metric

ISO 9766 shank, -7



- Internal coolant
- For insert information see page(s) 197-200
- For cutting data see page(s) 208
- Spare parts and accessories see page(s) 185

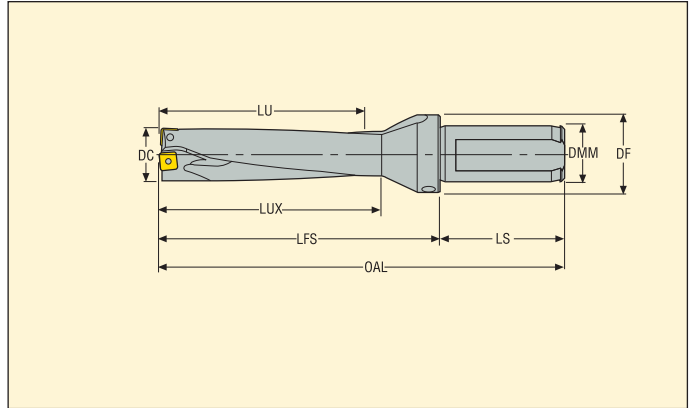

DC (mm)	LU	Ordering and Product No.	Designation	Dimensions in mm						Insert	
				OAL	LFS	LS	LUX	DMM	DF	Centre insert	Periph insert
17,0	68	03080330	SD524-17-68-25R7	154	98	56	73	25	35	SPGX0502	SCGX050204
17,5	70	03080326	SD524-17.5-70-25R7	156	100	56	75	25	35	SPGX0602	SCGX050204
18,0	72	03080333	SD524-18-72-25R7	158	102	56	77	25	35	SPGX0602	SCGX050204
18,5	74	03080331	SD524-18.5-74-25R7	160	104	56	79	25	35	SPGX0602	SCGX050204
19,0	76	03080336	SD524-19-76-25R7	162	106	56	81	25	35	SPGX0602	SCGX050204
20,0	80	03080340	SD524-20-80-25R7	166	110	56	85	25	35	SPGX0602	SCGX060204
21,0	84	03080344	SD524-21-84-25R7	170	114	56	89	25	35	SPGX0602	SCGX060204
22,0	88	03080348	SD524-22-88-25R7	174	118	56	93	25	35	SPGX0703	SCGX060204
23,0	92	03080351	SD524-23-92-25R7	178	122	56	97	25	35	SPGX0703	SCGX070308
24,0	96	03080352	SD524-24-96-25R7	182	126	56	101	25	35	SPGX0703	SCGX070308
25,0	100	03080353	SD524-25-100-32R7	190	130	60	105	32	42	SPGX0703	SCGX070308
26,0	104	03080354	SD524-26-104-32R7	194	134	60	109	32	42	SPGX0903	SCGX070308
27,0	108	03080355	SD524-27-108-32R7	198	138	60	113	32	42	SPGX0903	SCGX070308
28,0	112	03080356	SD524-28-112-32R7	202	142	60	117	32	42	SPGX0903	SCGX070308
29,0	116	03080357	SD524-29-116-32R7	206	146	60	121	32	42	SPGX0903	SCGX09T308
30,0	120	03080358	SD524-30-120-32R7	210	150	60	125	32	42	SPGX0903	SCGX09T308
31,0	124	03080360	SD524-31-124-32R7	214	154	60	129	32	42	SPGX0903	SCGX09T308
32,0	128	03080361	SD524-32-128-40R7	226	158	68	133	40	50	SPGX11T3	SCGX09T308
33,0	132	03080362	SD524-33-132-40R7	230	162	68	137	40	50	SPGX11T3	SCGX09T308
34,0	136	03080363	SD524-34-136-40R7	234	166	68	141	40	50	SPGX11T3	SCGX09T308
35,0	140	03080364	SD524-35-140-40R7	238	170	68	145	40	50	SPGX11T3	SCGX11T308
36,0	144	03080365	SD524-36-144-40R7	242	174	68	149	40	50	SPGX11T3	SCGX11T308
37,0	148	03080366	SD524-37-148-40R7	246	178	68	153	40	50	SPGX11T3	SCGX11T308
38,0	152	03080367	SD524-38-152-40R7	250	182	68	157	40	50	SPGX12T3	SCGX11T308
39,0	156	03080368	SD524-39-156-40R7	254	186	68	161	40	50	SPGX12T3	SCGX11T308
40,0	160	03080369	SD524-40-160-40R7	258	190	68	165	40	50	SPGX12T3	SCGX11T308
41,0	164	03080370	SD524-41-164-40R7	262	194	68	169	40	50	SPGX12T3	SCGX120408
42,0	168	03080371	SD524-42-168-40R7	266	198	68	173	40	50	SPGX12T3	SCGX120408
43,0	172	03080372	SD524-43-172-40R7	270	202	68	177	40	50	SPGX12T3	SCGX120408
44,0	176	03080373	SD524-44-176-40R7	274	206	68	181	40	50	SPGX1504	SCGX120408
45,0	180	03080374	SD524-45-180-40R7	278	210	68	185	40	50	SPGX1504	SCGX150512
46,0	184	03080375	SD524-46-184-40R7	282	214	68	189	40	50	SPGX1504	SCGX150512
47,0	188	03080376	SD524-47-188-40R7	286	218	68	193	40	50	SPGX1504	SCGX150512
48,0	192	03080377	SD524-48-192-40R7	290	222	68	197	40	59	SPGX1504	SCGX150512
49,0	196	03080378	SD524-49-196-40R7	294	226	68	201	40	59	SPGX1504	SCGX150512
50,0	200	03080379	SD524-50-200-40R7	298	230	68	205	40	59	SPGX1504	SCGX150512
51,0	204	03080380	SD524-51-204-40R7	302	234	68	209	40	59	SPGX1504	SCGX150512
52,0	208	03080381	SD524-52-208-40R7	306	238	68	213	40	59	SPGX1904	SCGX150512
53,0	212	03080382	SD524-53-212-40R7	310	242	68	217	40	59	SPGX1904	SCGX150512
54,0	216	03080383	SD524-54-216-40R7	314	246	68	221	40	59	SPGX1904	SCGX150512
55,0	220	03080384	SD524-55-220-40R7	318	250	68	225	40	59	SPGX1904	SCGX150512

For intermediate diameters see the MyDesign software.

Drilling depth ~ 4 x D – Metric

ABS 50 compatible shank, -2



- Internal coolant
- For insert information see page(s) 197-200
- For cutting data see page(s) 208
- Spare parts and accessories see page(s) 185

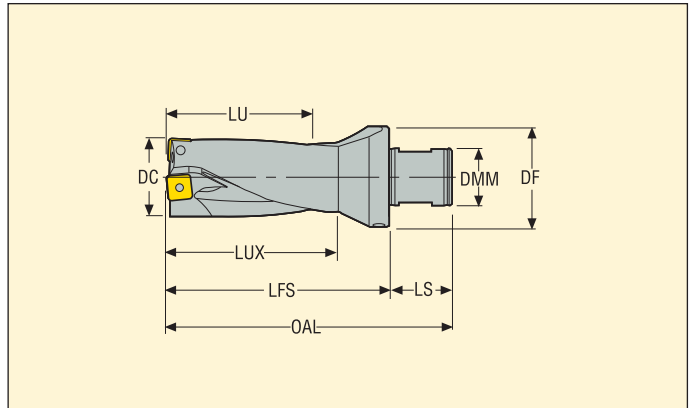

DC (mm)	LU	Ordering and Product No.	Designation	Dimensions in mm						Insert	
				OAL	LFS	LS	LUX	DMM	DF	Centre insert	Periph insert
17,0	68	03080208	SD524-17-68-50R2	129	98	31	73	28	50	SPGX0502	SCGX050204
17,5	70	03080327	SD524-17.5-70-50R2	131	100	31	75	28	50	SPGX0602	SCGX050204
18,0	72	03080209	SD524-18-72-50R2	133	102	31	77	28	50	SPGX0602	SCGX050204
18,5	74	03080210	SD524-18.5-74-50R2	135	104	31	79	28	50	SPGX0602	SCGX050204
19,0	76	03080422	SD524-19-76-50R2	137	106	31	81	28	50	SPGX0602	SCGX050204
20,0	80	03080341	SD524-20-80-50R2	141	110	31	85	28	50	SPGX0602	SCGX060204
20,62	83	03080215	SD524-20.62-83-50R2	144	113	31	88	28	50	SPGX0602	SCGX060204
21,0	84	03080345	SD524-21-84-50R2	145	114	31	89	28	50	SPGX0602	SCGX060204
22,0	88	03080193	SD524-22-88-50R2	149	118	31	93	28	50	SPGX0703	SCGX060204
22,23	89	03080216	SD524-22.23-89-50R2	150	119	31	94	28	50	SPGX0703	SCGX060204
23,0	92	03080194	SD524-23-92-50R2	153	122	31	97	28	50	SPGX0703	SCGX070308
24,0	96	03080195	SD524-24-96-50R2	157	126	31	101	28	50	SPGX0703	SCGX070308
25,0	100	03080196	SD524-25-100-50R2	161	130	31	105	28	50	SPGX0703	SCGX070308
25,4	102	03080217	SD524-25.4-102-50R2	163	132	31	107	28	50	SPGX0703	SCGX070308
26,0	104	03080423	SD524-26-104-50R2	165	134	31	109	28	50	SPGX0903	SCGX070308
27,0	108	03080197	SD524-27-108-50R2	169	138	31	113	28	50	SPGX0903	SCGX070308
28,0	112	03080424	SD524-28-112-50R2	173	142	31	117	28	50	SPGX0903	SCGX070308
28,59	115	03080218	SD524-28.59-115-50R2	176	145	31	120	28	50	SPGX0903	SCGX070308
29,0	116	03080198	SD524-29-116-50R2	177	146	31	121	28	50	SPGX0903	SCGX09T308
30,0	120	03080199	SD524-30-120-50R2	181	150	31	125	28	50	SPGX0903	SCGX09T308
31,0	124	03080200	SD524-31-124-50R2	185	154	31	129	28	50	SPGX0903	SCGX09T308
31,75	127	03080359	SD524-31.75-127-50R2	188	157	31	132	50	50	SPGX11T3	SCGX09T308
32,0	128	03080425	SD524-32-128-50R2	189	158	31	133	28	50	SPGX11T3	SCGX09T308
33,0	132	03080201	SD524-33-132-50R2	193	162	31	137	28	50	SPGX11T3	SCGX09T308
34,0	136	03080207	SD524-34-136-50R2	197	166	31	141	28	50	SPGX11T3	SCGX09T308
35,0	140	03080202	SD524-35-140-50R2	201	170	31	145	28	50	SPGX11T3	SCGX11T308
36,0	144	03080203	SD524-36-144-50R2	205	174	31	149	28	50	SPGX11T3	SCGX11T308
37,0	148	03080204	SD524-37-148-50R2	209	178	31	153	28	50	SPGX11T3	SCGX11T308
38,0	152	03080426	SD524-38-152-50R2	213	182	31	157	28	50	SPGX12T3	SCGX11T308
39,0	156	03080205	SD524-39-156-50R2	217	186	31	161	28	50	SPGX12T3	SCGX11T308
40,0	160	03080206	SD524-40-160-50R2	221	190	31	165	28	50	SPGX12T3	SCGX11T308

For intermediate diameters see the MyDesign software.

Drilling depth ~ 4 x D – Metric

Seco-Capto™ C4 shank

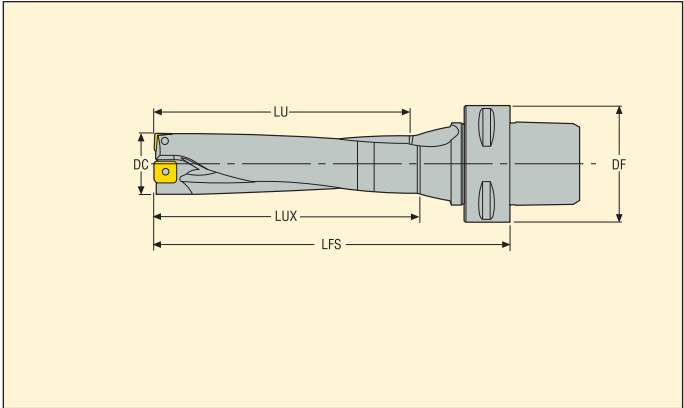

- Internal coolant
- For insert information see page(s) 197-200
- For cutting data see page(s) 208
- Spare parts and accessories see page(s) 185

DC (mm)	LU	Ordering and Product No.	Designation	Dimensions in mm			Insert	
				LUX	LFS	DF	Centre insert	Periph insert
17,0	68	03080219	SD524-17-68-C4	73	106	40	SPGX0502	SCGX050204
17,5	70	03080220	SD524-17.5-70-C4	75	109	40	SPGX0602	SCGX050204
18,0	72	03080221	SD524-18-72-C4	77	111	40	SPGX0602	SCGX050204
18,5	74	03080222	SD524-18.5-74-C4	79	113	40	SPGX0602	SCGX050204
19,0	76	03080223	SD524-19-76-C4	81	115	40	SPGX0602	SCGX050204
20,0	80	03080224	SD524-20-80-C4	85	121	40	SPGX0602	SCGX060204
20,62	83	03080413	SD524-20.62-83-C4	88	124	40	SPGX0602	SCGX060204
21,0	84	03080225	SD524-21-84-C4	89	125	40	SPGX0602	SCGX060204
22,0	88	03080226	SD524-22-88-C4	93	129	40	SPGX0703	SCGX060204
22,23	89	03080414	SD524-22.23-89-C4	94	130	40	SPGX0703	SCGX060204
23,0	92	03080227	SD524-23-92-C4	97	134	40	SPGX0703	SCGX070308
24,0	96	03080228	SD524-24-96-C4	101	139	40	SPGX0703	SCGX070308
25,0	100	03080229	SD524-25-100-C4	105	144	40	SPGX0703	SCGX070308
25,4	102	03080415	SD524-25.4-102-C4	107	146	40	SPGX0703	SCGX070308
26,0	104	03080230	SD524-26-104-C4	109	148	40	SPGX0903	SCGX070308
27,0	108	03080231	SD524-27-108-C4	113	152	40	SPGX0903	SCGX070308
28,0	112	03080232	SD524-28-112-C4	117	157	40	SPGX0903	SCGX070308
28,59	115	03080416	SD524-28.59-115-C4	120	160	40	SPGX0903	SCGX070308
29,0	116	03080233	SD524-29-116-C4	121	161	40	SPGX0903	SCGX09T308
30,0	120	03080234	SD524-30-120-C4	125	165	40	SPGX0903	SCGX09T308

For intermediate diameters see the MyDesign software.

Drilling depth ~ 4 x D – Metric

Seco-Capto™ C5 shank



- Internal coolant
- For insert information see page(s) 197-200
- For cutting data see page(s) 208
- Spare parts and accessories see page(s) 185

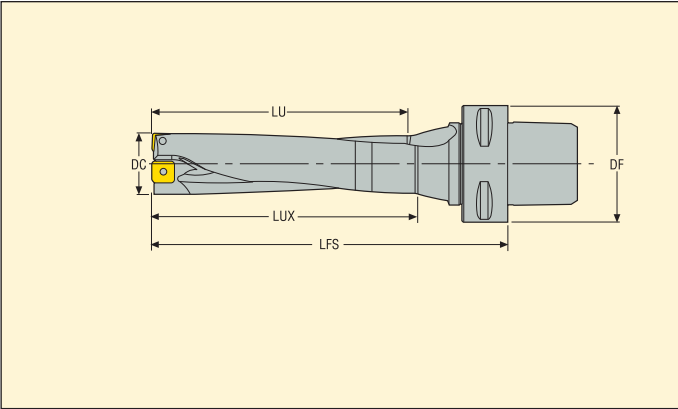

DC (mm)	LU	Ordering and Product No.	Designation	Dimensions in mm			Insert	
				LUX	LFS	DF	Centre insert	Periph insert
17,0	68	03080235	SD524-17-68-C5	73	106	50	SPGX0502	SCGX050204
17,5	70	03080237	SD524-17.5-70-C5	75	109	50	SPGX0602	SCGX050204
18,0	72	03080238	SD524-18-72-C5	77	111	50	SPGX0602	SCGX050204
18,5	74	03080239	SD524-18.5-74-C5	79	113	50	SPGX0602	SCGX050204
19,0	76	03080240	SD524-19-76-C5	81	115	50	SPGX0602	SCGX050204
20,0	80	03080241	SD524-20-80-C5	85	121	50	SPGX0602	SCGX060204
20,62	83	03080408	SD524-20.62-83-C5	88	124	50	SPGX0602	SCGX060204
21,0	84	03080242	SD524-21-84-C5	89	125	50	SPGX0602	SCGX060204
22,0	88	03080243	SD524-22-88-C5	93	129	50	SPGX0703	SCGX060204
22,23	89	03080409	SD524-22.23-89-C5	94	130	50	SPGX0703	SCGX060204
23,0	92	03080244	SD524-23-92-C5	97	134	50	SPGX0703	SCGX070308
24,0	96	03080245	SD524-24-96-C5	101	139	50	SPGX0703	SCGX070308
25,0	100	03080246	SD524-25-100-C5	105	144	50	SPGX0703	SCGX070308
25,4	102	03080410	SD524-25.4-102-C5	107	146	50	SPGX0703	SCGX070308
26,0	104	03080247	SD524-26-104-C5	109	148	50	SPGX0903	SCGX070308
27,0	108	03080248	SD524-27-108-C5	113	152	50	SPGX0903	SCGX070308
28,0	112	03080249	SD524-28-112-C5	117	157	50	SPGX0903	SCGX070308
28.59	115	03080411	SD524-28.59-115-C5	120	160	50	SPGX0903	SCGX070308
29,0	116	03080250	SD524-29-116-C5	121	161	50	SPGX0903	SCGX09T308
30,0	120	03080251	SD524-30-120-C5	125	165	50	SPGX0903	SCGX09T308
31,0	124	03080252	SD524-31-124-C5	129	169	50	SPGX0903	SCGX09T308
31.75	127	03080412	SD524-31.75-127-C5	132	173	50	SPGX11T3	SCGX09T308
32,0	128	03080253	SD524-32-128-C5	133	174	50	SPGX11T3	SCGX09T308
33,0	132	03080254	SD524-33-132-C5	137	178	50	SPGX11T3	SCGX09T308
34,0	136	03080255	SD524-34-136-C5	141	182	50	SPGX11T3	SCGX09T308
35,0	140	03080256	SD524-35-140-C5	145	186	50	SPGX11T3	SCGX11T308
36,0	144	03080257	SD524-36-144-C5	149	190	50	SPGX11T3	SCGX11T308
37,0	148	03080258	SD524-37-148-C5	153	194	50	SPGX11T3	SCGX11T308
38,0	152	03080259	SD524-38-152-C5	157	198	50	SPGX12T3	SCGX11T308
39,0	156	03080260	SD524-39-156-C5	161	202	50	SPGX12T3	SCGX11T308
40,0	160	03080261	SD524-40-160-C5	165	206	50	SPGX12T3	SCGX11T308

For intermediate diameters see the MyDesign software.

Drilling depth ~ 4 x D – Metric

Seco-Capto™ C6 shank

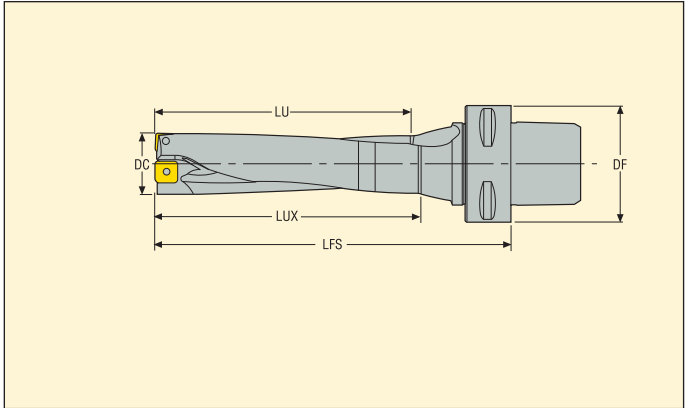

- Internal coolant
- For insert information see page(s) 197-200
- For cutting data see page(s) 207-208
- Spare parts and accessories see page(s) 185

DC (mm)	LU	Ordering and Product No.	Designation	Dimensions in mm			Insert	
				LUX	LFS	DF	Centre insert	Periph insert
17,0	68	03080262	SD524-17-68-C6	73	108	63	SPGX0502	SCGX050204
17,5	70	03080263	SD524-17.5-70-C6	75	111	63	SPGX0602	SCGX050204
18,0	72	03080265	SD524-18-72-C6	77	113	63	SPGX0602	SCGX050204
18,5	74	03080266	SD524-18.5-74-C6	79	115	63	SPGX0602	SCGX050204
19,0	76	03080267	SD524-19-76-C6	81	117	63	SPGX0602	SCGX050204
20,0	80	03080268	SD524-20-80-C6	85	123	63	SPGX0602	SCGX060204
20,62	83	03080417	SD524-20.62-83-C6	88	126	63	SPGX0602	SCGX060204
21,0	84	03080269	SD524-21-84-C6	89	127	63	SPGX0602	SCGX060204
22,0	88	03080270	SD524-22-88-C6	93	131	63	SPGX0703	SCGX060204
22,23	89	03080418	SD524-22.23-89-C6	94	132	63	SPGX0703	SCGX060204
23,0	92	03080271	SD524-23-92-C6	97	136	63	SPGX0703	SCGX070308
24,0	96	03080272	SD524-24-96-C6	101	141	63	SPGX0703	SCGX070308
25,0	100	03080392	SD524-25-100-C6	105	146	63	SPGX0703	SCGX070308
25,4	102	03080419	SD524-25.4-102-C6	107	148	63	SPGX0703	SCGX070308
26,0	104	03080393	SD524-26-104-C6	109	150	63	SPGX0903	SCGX070308
27,0	108	03080394	SD524-27-108-C6	113	154	63	SPGX0903	SCGX070308
28,0	112	03080395	SD524-28-112-C6	117	159	63	SPGX0903	SCGX070308
28,59	115	03080420	SD524-28.59-115-C6	120	162	63	SPGX0903	SCGX070308
29,0	116	03080396	SD524-29-116-C6	121	163	63	SPGX0903	SCGX09T308
30,0	120	03080397	SD524-30-120-C6	125	167	63	SPGX0903	SCGX09T308
31,0	124	03080398	SD524-31-124-C6	129	171	63	SPGX0903	SCGX09T308
31,75	127	03080421	SD524-31.75-127-C6	132	175	63	SPGX0903	SCGX09T308
32,0	128	03080399	SD524-32-128-C6	133	176	63	SPGX11T3	SCGX09T308
33,0	132	03080400	SD524-33-132-C6	137	180	63	SPGX11T3	SCGX09T308
34,0	136	03080401	SD524-34-136-C6	141	184	63	SPGX11T3	SCGX09T308
35,0	140	03080402	SD524-35-140-C6	145	188	63	SPGX11T3	SCGX11T308
36,0	144	03080403	SD524-36-144-C6	149	192	63	SPGX11T3	SCGX11T308
37,0	148	03080404	SD524-37-148-C6	153	196	63	SPGX11T3	SCGX11T308
38,0	152	03080405	SD524-38-152-C6	157	200	63	SPGX12T3	SCGX11T308
39,0	156	03080406	SD524-39-156-C6	161	204	63	SPGX12T3	SCGX11T308
40,0	160	03080407	SD524-40-160-C6	165	208	63	SPGX12T3	SCGX11T308

For intermediate diameters see the MyDesign software.

Drilling depth ~ 5 x D – Metric

ISO 9766 shank, -7



- Internal coolant
- For insert information see page(s) 197-200
- For cutting data see page(s) 209-210
- Spare parts and accessories see page(s) 185

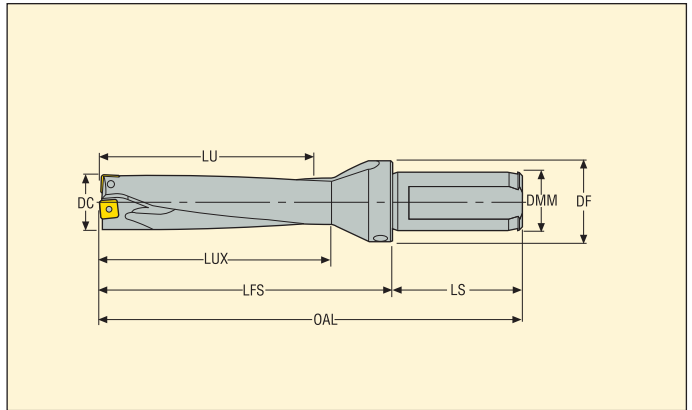

DC (mm)	LU	Ordering and Product No.	Designation	Dimensions in mm						Insert	
				OAL	LFS	LS	LUX	DMM	DF	Centre insert	Periph insert
19	95	03079580	SD525-19-95-25R7	181	125	56	100	25	35	SPGX0602	SCGX050204
20	100	03079582	SD525-20-100-25R7	186	130	56	105	25	35	SPGX0602	SCGX060204
21	105	03079583	SD525-21-105-25R7	191	135	56	110	25	35	SPGX0602	SCGX060204
22	110	03079584	SD525-22-110-25R7	196	140	56	115	25	35	SPGX0703	SCGX060204
23	115	03079585	SD525-23-115-25R7	201	145	56	120	25	35	SPGX0703	SCGX070308
24	120	03079586	SD525-24-120-25R7	206	150	56	125	25	35	SPGX0703	SCGX070308
25	125	03079587	SD525-25-125-32R7	215	155	60	130	32	42	SPGX0703	SCGX070308
26	130	03079588	SD525-26-130-32R7	220	160	60	135	32	42	SPGX0903	SCGX070308
27	135	03079589	SD525-27-135-32R7	225	165	60	140	32	42	SPGX0903	SCGX070308
28	140	03079590	SD525-28-140-32R7	230	170	60	145	32	42	SPGX0903	SCGX070308
29	145	03079591	SD525-29-145-32R7	235	175	60	150	32	42	SPGX0903	SCGX09T308
30	150	03079592	SD525-30-150-32R7	240	180	60	155	32	42	SPGX0903	SCGX09T308
31	155	03079593	SD525-31-155-32R7	245	185	60	160	32	42	SPGX0903	SCGX09T308
32	160	03079595	SD525-32-160-40R7	258	190	68	165	40	50	SPGX11T3	SCGX09T308
33	165	03079596	SD525-33-165-40R7	263	195	68	170	40	50	SPGX11T3	SCGX09T308
34	170	03079597	SD525-34-170-40R7	268	200	68	175	40	50	SPGX11T3	SCGX09T308
35	175	03079598	SD525-35-175-40R7	273	205	68	180	40	50	SPGX11T3	SCGX11T308
36	180	03079599	SD525-36-180-40R7	278	210	68	185	40	50	SPGX11T3	SCGX11T308
37	185	03079600	SD525-37-185-40R7	283	215	68	190	40	50	SPGX11T3	SCGX11T308
38	190	03079601	SD525-38-190-40R7	288	220	68	195	40	50	SPGX12T3	SCGX11T308
39	195	03079602	SD525-39-195-40R7	293	225	68	200	40	50	SPGX12T3	SCGX11T308
40	200	03079603	SD525-40-200-40R7	298	230	68	205	40	50	SPGX12T3	SCGX11T308
41	205	03079604	SD525-41-205-40R7	303	235	68	210	40	50	SPGX12T3	SCGX120408
42	210	03079605	SD525-42-210-40R7	308	240	68	215	40	50	SPGX12T3	SCGX120408
43	215	03079606	SD525-43-215-40R7	313	245	68	220	40	50	SPGX12T3	SCGX120408
44	220	03079607	SD525-44-220-40R7	318	250	68	225	40	50	SPGX1504	SCGX120408
45	225	03079608	SD525-45-225-40R7	323	255	68	230	40	50	SPGX1504	SCGX150512

For intermediate diameters see the MyDesign software.

Drilling depth ~ 2,5 X D

ISO 9766 shank, -7



- Internal 'through' coolant
- For insert information see page(s) 197-200
- For cutting data see page(s) 211-212
- Spare parts and accessories see page(s) 185

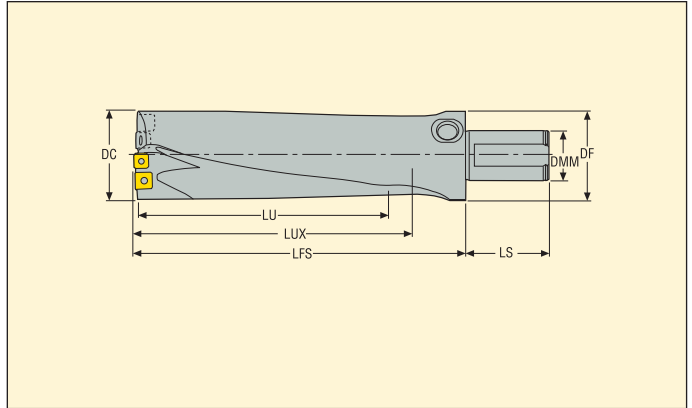

DC	LU	Ordering and Product No.	Designation	Dimensions in mm					Insert	
				LFS	LS	LUX	DMM	DF	Centre insert	Periph insert
60	150,0	02590456	SD542-60-150-40R7	201,5	68	156,0	40	79	SPGX0903-C1	SCGX09T308..
65	162,5	02590457	SD542-65-162.5-40R7	214,0	68	169,5	40	79	SPGX11T3-C1	SCGX09T308..
70	175,0	02590458	SD542-70-175-40R7	226,5	68	182,5	40	79	SPGX11T3-C1	SCGX120408..
75	187,5	02590459	SD542-75-187.5-50R7	239,0	78	196,0	50	79	SPGX11T3-C1	SCGX120408..
80	200,0	02590460	SD542-80-200-50R7	251,5	78	210,0	50	79	SPGX12T3-C1	SCGX120408..
85	212,5	02590461	SD542-85-212.5-50R7	264,0	78	221,0	50	89	SPGX12T3-C1	SCGX120408..

For intermediate diameters see Custom Design software.

Drilling depth ~ 2 X D

Seco-Capto™ C5 shank



- Internal coolant
- For insert information see page(s) 201-202
- For cutting data see page(s) 213-214
- Spare parts and accessories see page(s) 185

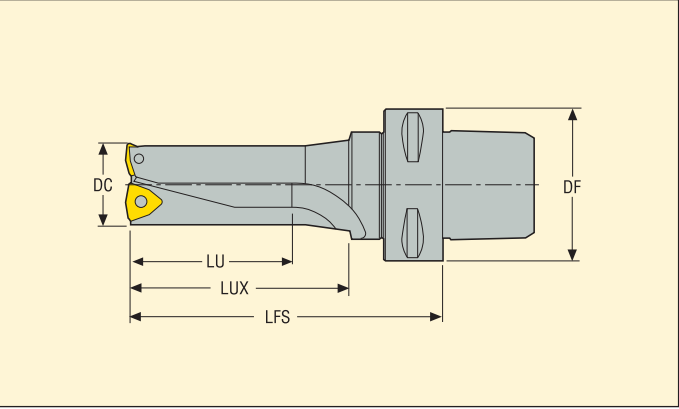



DC	Hole dia min-max (mm)	LU	Ordering and Product No.	Designation	Dimensions in mm			Insert	
					LFS	LUX	DF	Centre insert	Periph insert
15	14,8-18	30	02595831	SD572-15-30-C5	85	35	50	WCMX030208-86	WCMX030208..
16	15,8-18	32	02595832	SD572-16-32-C5	87	37	50	WCMX030208-86	WCMX030208..
17	16,8-19	34	02595833	SD572-17-34-C5	89	39	50	WCMX030208-86	WCMX030208..
19	18,8-22	38	02595834	SD572-19-38-C5	93	43	50	WCMX040208-86	WCMX030208..
22	21,8-27	44	02595835	SD572-22-44-C5	99	49	50	WCMX050308-86	WCMX040208..
27	26,8-33	54	02595836	SD572-27-54-C5	109	59	50	WCMX06T308-86	WCMX050308..
33	32,8-41	66	02595837	SD572-33-66-C5	121	71	50	WCMX080412-86	WCMX06T308..
41	40,8-47	82	02595838	SD572-41-82-C5	157	87	50	WCMX080412-86	WCMX080412..
47	46,8-52	94	02595839	SD572-47-94-C5	169	99	50	WCMX080412-86	WCMX080412..

For intermediate diameters see Custom Design software.

Spare Parts – metric – SD522, SD523, SD524 & SD525

For drill dia. (mm)	Insert screw		Insert key
	Centre insert	Periph insert	
15,00-17,45	C02245-T07P	C02245-T07P	T07P-2
17,46-19,49	C02205-T07P	C02245-T07P	T07P-2
19,50-21,24	C02205-T07P	C02205-T07P	T07P-2
21,25-22,49	C02506-T08P	C02506-T08P	T08P-2
22,50-25,49	C02507-T08P	C03007-T08P	T08P-2
25,50-28,49	C03007-T09P	C03007-T09P	T09P-2
28,50-31,49	C03007-T09P	C03009-T09P	T09P-2
31,50-40,49	C03508-T15P	C03508-T15P	T15P-2D
40,50-43,24	C03508-T15P	C05012-T15P	T15P-2D
43,25-59,00	C04011-T15P	C05012-T15P	T15P-2D

Accessories

Torque wrench	Replacement blade	Torque value
		
T00-07P09	T00-07P	0,9 Nm
T00-07P09	T00-07P	0,9 Nm
T00-07P09	T00-07P	0,9 Nm
T00-08P12	T00-08P	1,2 Nm
T00-08P12	T00-08P	1,2 Nm
T00-09P20	T00-09P	2,0 Nm
T00-09P20	T00-09P	2,0 Nm
T00-15P30	T00-15P	3,0 Nm
T00-15P30	T00-15P	3,0 Nm
T00-15P30	T00-15P	3,0 Nm

Spare Parts – metric – SD542

For drill dia. (mm)	Insert screw		Insert key	Plug	Hose adapter	Torque wrench	Replacement blade	Torque value
	Centre insert	Periph insert						
60,00-64,99	C03007-T09P	C03009-T09P	T09P-2	R3/8	R3/8-HA	T00-09P20	T00-09P	3,0 Nm
65,00-68,99	C03508-T15P	C03508-T15P	T15P-2D	R3/8	R3/8-HA	T00-15P30	T00-15P	3,0 Nm
69,00-86,99	C03508-T15P	C05012-T15P	T15P-2D	R3/8	R3/8-HA	T00-15P30	T00-15P	3,0 Nm

Accessories

Spare Parts – metric – SD572

For drill dia. (mm)	Insert screw		Insert key	Plug	Hose adapter	Torque wrench	Replacement blade	Torque value
	Centre insert	Periph insert						
15,00-20,50	C02205-T07P	C02205-T07P	T07P-2	R1/4	1310	T00-07P09	T00-07P	0,9 Nm
20,51-24,50	C03007-T08P	C02506-T08P	T08P-2	R1/4	1310	T00-08P12	T00-08P	1,2 Nm
24,51-32,50	C03508-T15P	C03007-T08P	T08P-2, T15P-2D	R1/4	1310	T00-08P12	T00-08P	1,2 Nm
32,51-36,50	C03508-T15P	C03508-T15P	T15P-2D	R1/4	1310	T00-15P30	T00-15P	3,0 Nm
36,51-59,00	C04011-T15P	C04011-T15P	T15P-2D	R1/4	1310	T00-15P30	T00-15P	3,0 Nm

Accessories

Accessories, to be ordered separately

*Including blade.



Code key – Drill bodies

Type of drill:
SD602 Pilot drill and cassette
SD612 Without pilot drill and cassette

Flange diameter

Connection for Graflex

SD602 - 89/90 - 50 RG

Possible drill diameter
89 - Lower diameter
90 - Nominal diameter



Code key – Pilot drill

Drill diameter

SD601 - 1 - 10 - R

0=Solid carbide
1=HSS

Right-hand rotation



Code key – Cassette

N - Nominal diameter

SD600 - C - 07 - N

C - Centre
P - Periphery

Insert size:
SCGX07
SCGX09
SCGX12
SCGX15



-N



Code key – Kit

Periphery

SD602 - 1 - P - 07 - N

0 = incl 2 pads (\varnothing 135 mm)
1 = incl 4 pads ($\geq \varnothing$ 135 mm)

Insert size
SCGX07
SCGX09
SCGX12
SCGX15

N - Nominal diameter
U - Undersize diameter



-N



-U

Code key – Pad

PAD - L20R25 - N

N - Nominal diameter



Modular drill head assembly

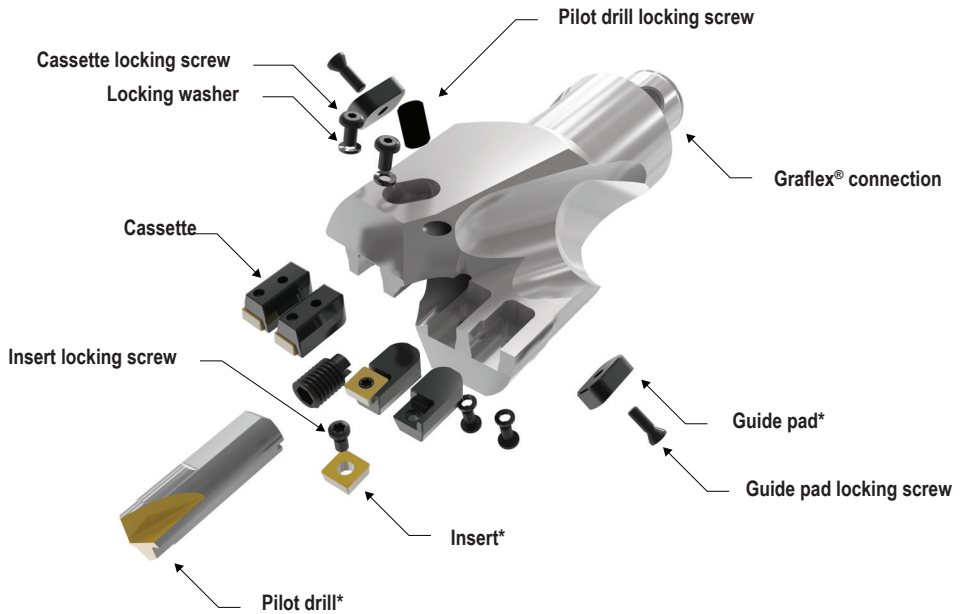

SD602-59/60-40RG



Example: Diameter 59 mm
Use kit: SD6020-P07*



Example: Diameter 60 mm
Use kit: SD6020-P07-N*

Mounting instruction	Mounting of cartridge and guide pad	
<ul style="list-style-type: none"> • Tighten the cassette locking screw • Mount the inserts • Mount the pilot drill and fix it to the bottom of the hole if you need to extend the pilot drill use the adjusting screw • Mount the extensions 	<ul style="list-style-type: none"> • Mount the cassette • Make sure that there are no air gaps between the cassette and the walls • Tighten the cassette locking screw with the torque key: SD600-x-07: 3 Nm SD600-x-09: 3 Nm SD600-x-12: 8 Nm SD600-x-15: 8 Nm • Mount the guide pad • Tighten the pad locking screw 	

* Not included in delivery. Periph kit, pilot drill and inserts needs to be ordered seperately.

SD602 - Modular drill head



- Internal coolant
- For insert information see page(s) 197-198
- For cutting data see page(s) 215-216
- Adjustable length pilot drill

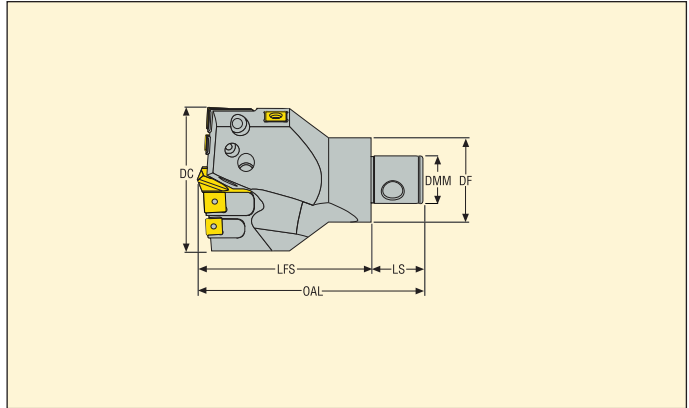

DC	Ordering and Product No.	Designation	Dimensions in mm					Graflex size	Insert	KG
			OAL	LFS	LS	DF	DMM			
59,0-60,0	02846688	SD602-59/60-40RG	129	105	24	40	22	G4	SCGX07	0,9
69,0-70,0	02846689	SD602-69/70-40RG	129	105	24	40	22	G4	SCGX09	1,1
79,0-80,0	02846690	SD602-79/80-50RG	160	130	30	50	28	G5	SCGX09	1,8
89,0-90,0	02846691	SD602-89/90-50RG	160	130	30	50	28	G5	SCGX09/12	2,0
99,0-100,0	02846692	SD602-99/100-63RG	185	145	40	63	36	G6	SCGX12	3,1
119,0-120,0	02846693	SD602-119/120-63RG	185	145	40	63	36	G6	SCGX15	3,5
139,0-140,0	02846694	SD602-139/140-90RG	210	160	50	90	46	G7	SCGX12	6,1
159,0-160,0	02846695	SD602-159/160-90RG	210	160	50	90	46	G7	SCGX12/15	6,6
62,5-63,5	02846698	SD602-2500-40RG	129	105	24	40	22	G4	SCGX07	1,0
68,85-69,85	02846699	SD602-2750-40RG	129	105	24	40	22	G4	SCGX07/09	1,1
75,2-76,2	02846700	SD602-3000-40RG	129	105	24	40	22	G4	SCGX09	1,1
81,55-82,55	02846701	SD602-3250-50RG	160	130	30	50	28	G5	SCGX09/12	1,8
87,9-88,9	02846702	SD602-3500-50RG	160	130	30	50	28	G5	SCGX09/12	1,9
100,6-101,6	02846703	SD602-4000-63RG	185	145	40	63	36	G6	SCGX12	3,2

Spare parts

Cassette*	Cassette	Cassette screw	Washer	Insert screw	Insert key	Guide pad*	Guide pad*	Pad screw
SD600-x-07	SD600-P-07-N	K6S4x8	LW0408	C03007-T09P	T09P-2, T15P-2D	PAD-L20R25	PAD-L20R25-N	C04014-T15P
SD600-x-09	SD600-P-09-N	K6S4x8	LW0408	C03508-T15P	T15P-2D	PAD-L20R25	PAD-L20R25-N	C04014-T15P
SD600-x-12	SD600-P-12-N	K6S6x12	LW0611	C05012-T15P	T15P-2D	PAD-L20R25	PAD-L20R25-N	C04014-T15P
SD600-x-15	SD600-P-15-N	K6S6x12	LW0611	C05012-T15P	T15P-2D	PAD-L20R25	PAD-L20R25-N	C04014-T15P

*Not included in delivery

SD602 - Modular drill head

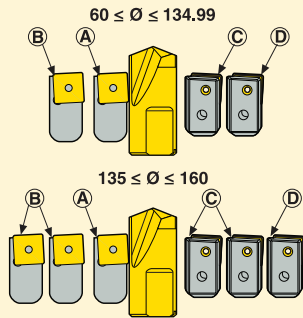

Spare Parts, parts included in delivery

Designation	For drill dia. (mm)	For drill dia. (inch)	Pilot screw	Adjusting screw	Cassette (A)	Cassette (B)	Cassette (C)	Periph kit** (D)	Pilot drill* x=0 Solid carbide x=1 HSS
SD602-59/60-40RG	59	2.323	P6SS 8X8	19TLR0816	SD600-C-07	SD600-C-07	SD600-P-07	SD6020-P-07-U	SD601x-10-R
SD602-59/60-40RG	60	2.362	P6SS 8X8	19TLR0816	SD600-C-07	SD600-C-07	SD600-P-07	SD6020-P-07-N	SD601x-10-R
SD602-2500-40RG	62,5	2.461	P6SS 8X8	19TLR0816	SD600-C-07	SD600-C-07	SD600-P-07	SD6020-P-07-U	SD601x-10-R
SD602-2500-40RG	63,5	2.500	P6SS 8X8	19TLR0816	SD600-C-07	SD600-C-07	SD600-P-07	SD6020-P-07-N	SD601x-10-R
SD602-2750-40RG	68,85	2.711	P6SS 8X8	19TLR0816	SD600-C-09	SD600-C-07	SD600-P-07	SD6020-P-07-U	SD601x-10-R
SD602-2750-40RG	69,85	2.750	P6SS 8X8	19TLR0816	SD600-C-09	SD600-C-07	SD600-P-07	SD6020-P-07-N	SD601x-10-R
SD602-69/70-40RG	69	2.717	P6SS 8X8	19TLR0816	SD600-C-09	SD600-C-09	SD600-P-09	SD6020-P-09-U	SD601x-10-R
SD602-69/70-40RG	70	2.756	P6SS 8X8	19TLR0816	SD600-C-09	SD600-C-09	SD600-P-09	SD6020-P-09-N	SD601x-10-R
SD602-3000-40RG	75,2	2.961	P6SS 10X10	19TLR1016	SD600-C-09	SD600-C-09	SD600-P-09	SD6020-P-09-U	SD601x-15-R
SD602-3000-40RG	76,2	3.000	P6SS 10X10	19TLR1016	SD600-C-09	SD600-C-09	SD600-P-09	SD6020-P-09-N	SD601x-15-R
SD602-79/80-50RG	79	3.110	P6SS 10X10	19TLR1016	SD600-C-09	SD600-C-09	SD600-P-09	SD6020-P-09-U	SD601x-15-R
SD602-79/80-50RG	80	3.150	P6SS 10X10	19TLR1016	SD600-C-09	SD600-C-09	SD600-P-09	SD6020-P-09-N	SD601x-15-R
SD602-3250-50RG	81,55	3.211	P6SS 10X10	19TLR1016	SD600-C-12	SD600-C-09	SD600-P-09	SD6020-P-09-U	SD601x-15-R
SD602-3250-50RG	82,55	3.250	P6SS 10X10	19TLR1016	SD600-C-12	SD600-C-09	SD600-P-09	SD6020-P-09-N	SD601x-15-R
SD602-3500-50RG	87,9	3.461	P6SS 10X10	19TLR1016	SD600-C-12	SD600-C-09	SD600-P-09	SD6020-P-12-U	SD601x-15-R
SD602-3500-50RG	88,9	3.500	P6SS 10X10	19TLR1016	SD600-C-12	SD600-C-09	SD600-P-09	SD6020-P-12-N	SD601x-15-R
SD602-89/90-50RG	89	3.504	P6SS 10X10	19TLR1016	SD600-C-12	SD600-C-09	SD600-P-09	SD6020-P-12-U	SD601x-15-R
SD602-89/90-50RG	90	3.543	P6SS 10X10	19TLR1016	SD600-C-12	SD600-C-09	SD600-P-09	SD6020-P-12-N	SD601x-15-R
SD602-99/100-63RG	99	3.898	P6SS 10X10	19TLR1016	SD600-C-12	SD600-C-12	SD600-P-12	SD6020-P-12-U	SD601x-15-R
SD602-99/100-63RG	100	3.937	P6SS 10X10	19TLR1016	SD600-C-12	SD600-C-12	SD600-P-12	SD6020-P-12-N	SD601x-15-R
SD602-4000-63RG	100,6	3.961	P6SS 10X10	19TLR1016	SD600-C-12	SD600-C-12	SD600-P-12	SD6020-P-12-U	SD601x-15-R
SD602-4000-63RG	101,6	4.000	P6SS 10X10	19TLR1016	SD600-C-12	SD600-C-12	SD600-P-12	SD6020-P-12-N	SD601x-15-R
SD602-119/120-63RG	119	4.685	P6SS 10X10	19TLR1016	SD600-C-15	SD600-C-15	SD600-P-15	SD6020-P-15-U	SD601x-15-R
SD602-119/120-63RG	120	4.724	P6SS 10X10	19TLR1016	SD600-C-15	SD600-C-15	SD600-P-15	SD6020-P-15-N	SD601x-15-R
SD602-139/140-90RG	139	5.472	P6SS 12X12	19TLR1216	SD600-C-12	SD600-C-12	SD600-P-12	SD6021-P-12-U	SD601x-25-R
SD602-139/140-90RG	140	5.512	P6SS 12X12	19TLR1216	SD600-C-12	SD600-C-12	SD600-P-12	SD6021-P-12-N	SD601x-25-R
SD602-159/160-90RG	159	6.260	P6SS 12X12	19TLR1216	SD600-C-15	SD600-C-12	SD600-P-12	SD6021-P-15-U	SD601x-25-R
SD602-159/160-90RG	160	6.299	P6SS 12X12	19TLR1216	SD600-C-15	SD600-C-12	SD600-P-12	SD6021-P-15-N	SD601x-25-R

**Periph kit, U-undersize, N-nominal.

*Not included in delivery.

For insert size see page 197-198



Regrinding instructions for SD602

1. Point angle

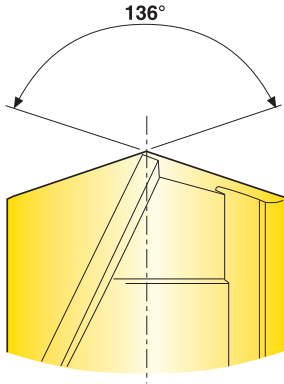

Edge preparation 0,1 mm x 20°. Drill point conical relief 10°.

2. Corner chamfer

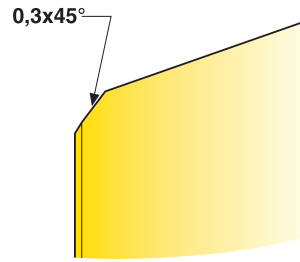

3.

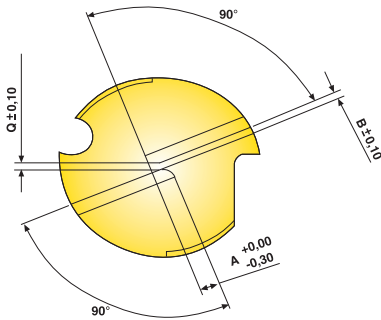

4.

Diameter	A	B	Q	Minimum (length)
10	1,5	0,5	0,57	38
15	1,5	0,6	0,68	45
25	1,5	1,4	1,6	57

Specifications

Proposed specification of diamond wheels:

Conical clearance: Wheel shape 12A2 Grit size D54 (figure 1).

Gashing: Wheel shape 1A1 or 1V1 Grit size D64-D46 (figure 3).

Corner chamfer: Wheel shape 1A1 or 12A2

Edge treatment: grinding K-land or brushing (figure 2).

Important:

The cutting edges must be uniform and have the same size of edge preparation. The edge preparation must be applied on the whole length of the cutting edges.

Modular drill head assembly

Feature: Adjustable pilot drill

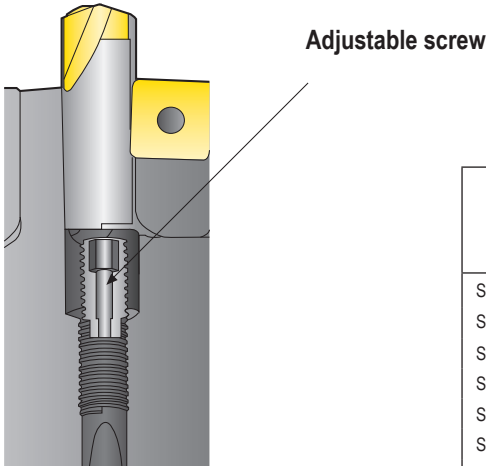

Drill	Adjustable length distance ADJRG	Pilot drill x=0 Solid carbide x=1 HSS drill
SD602-59/60-40RG	3 mm	SD601x-10-R
SD602-69/70-40RG	3 mm	SD601x-10-R
SD602-79/80-50RG	5 mm	SD601x-15-R
SD602-89/90-50RG	5 mm	SD601x-15-R
SD602-99/100-63RG	5 mm	SD601x-15-R
SD602-119/120-63RG	5 mm	SD601x-15-R
SD602-139/140-90RG	5 mm	SD601x-25-R
SD602-159/160-90RG	5 mm	SD601x-25-R
SD602-2500-40RG	3 mm	SD601x-10-R
SD602-2750-40RG	3 mm	SD601x-10-R
SD602-3000-40RG	5 mm	SD601x-15-R
SD602-3250-50RG	5 mm	SD601x-15-R
SD602-3500-50RG	5 mm	SD601x-15-R
SD602-4000-63RG	5 mm	SD601x-15-R

Adjustable length distance

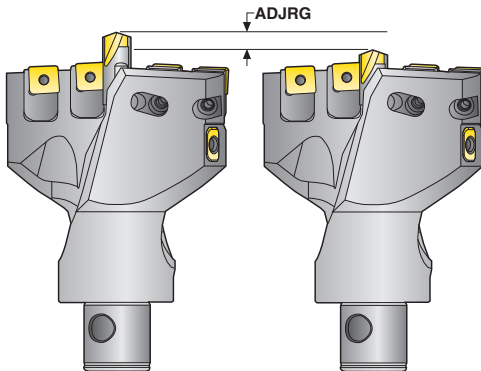

Benefits: Same setting length after regrinding of pilot drill.
 Possibility to adjust the pilot drill overhang.
 With drill depths > 5 x D it is recommended to adjust it 5 mm further out.

Recommendation: In case of re-entering the hole the pilot drill should be adjusted 3 mm further out from its original position to ensure a better centering.

Use HSS pilotdrill as first choice.

Pilotdrill are not included in delivery.

Modular drill head assembly

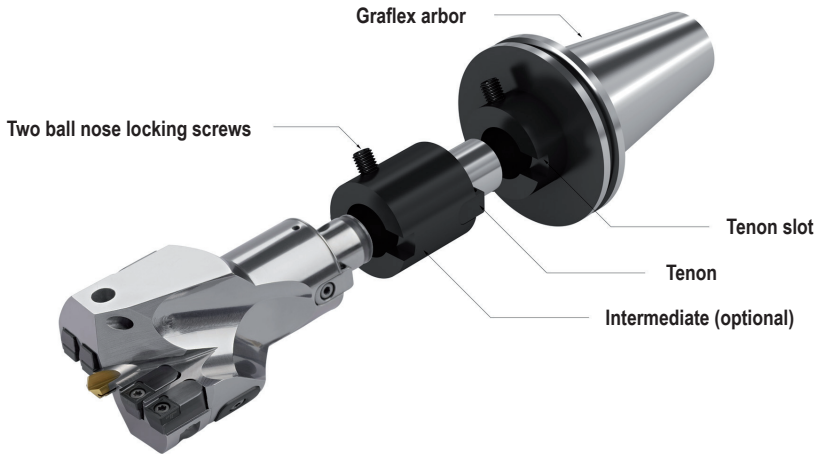

Mounting instruction

1. Clean the parts to be assembled and apply thin oxidation protection film.
2. Assemble the parts ensuring that the left face of the tenon contacts the left face of the tenon slot
3. Lightly tighten screw A
4. Lightly tighten screw B
5. 'Torque' the blocking screw C
6. 'Torque' screw A
7. 'Torque' screw B
8. Double check the blocking screw tightening

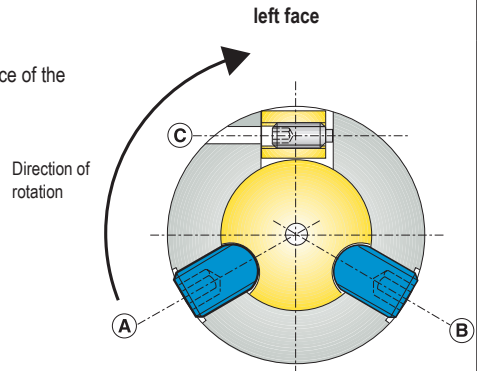

Graflex size	d mm	D mm	l _c mm	Recommended Graflex connection locking torques	
				Ball nose screws (A) & (B)	Tenon blocking screw (C)
4	22	40	24	20 Nm	0,7 Nm
5	28	50	30	25 Nm	2 Nm
6	36	63	40	35 Nm	4 Nm
7	46	90	50	60 Nm	8 Nm

Insert grade



Features:

- 4 cutting edges per insert
- Strong square inserts



Benefits:

- Economy
- Reliability
- Performance
- Low cost per hole

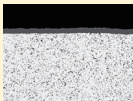
Peripheral insert

	DP2000	<ul style="list-style-type: none"> • DURATOMIC® coating technology • Optimized grade for steel and cast iron machining • For machining with very high cutting speeds • A unique combination of superior edge toughness and a thick wear resistant coating • Ti(C,N) + Al₂O₃ DURATOMIC®
	DP3000	<ul style="list-style-type: none"> • DURATOMIC® coating technology • Universal grade • Superior wear resistance and edge toughness • Tough grade for maximum application security • Ti(C,N) + Al₂O₃ DURATOMIC® • Gradient substrate
	T250D	<ul style="list-style-type: none"> • More suitable in harder materials • First choice in Aluminum • Tough micrograin with TiAlN coating ensures <ul style="list-style-type: none"> - Extremely good hardness - Extreme resistance to chemical wear and oxidation • PVD coated • (Ti, Al)N + TiN
	DS2050	<ul style="list-style-type: none"> • Optimized grade for Titanium, super alloys and difficult stainless steel • PVD coated • TiAlN + NbN

Centre insert

	T400D	<ul style="list-style-type: none"> • First choice • Tough center insert grade for maximum application security • PVD coated • (Ti, Al)N + TiN
	DP3000	<ul style="list-style-type: none"> • DURATOMIC® coating technology • Universal grade • Superior wear resistance and edge toughness • Tough grade for maximum application security • Ti(C,N) + Al₂O₃ DURATOMIC® • Gradient substrate
	DS4050	<ul style="list-style-type: none"> • Optimized grade for Titanium, super alloys and difficult stainless steel • PVD coated • TiAlN + NbN

Geometries

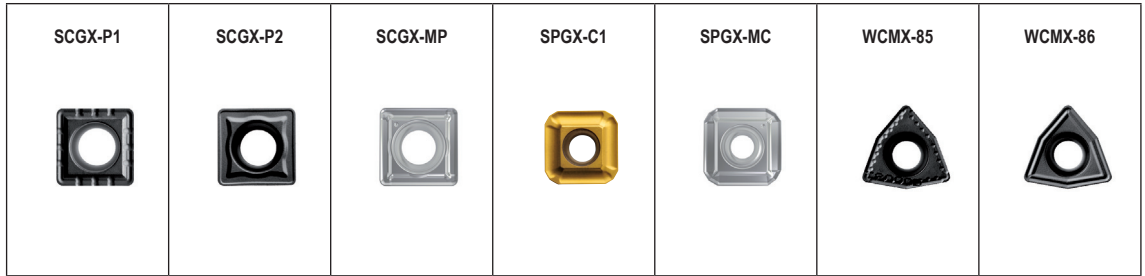

S	C	G	X	06	02	04	-	P1
1	2	3	4	5	6	7		10

1. Insert shape		2. Insert side clearance angle		4. Type
S	W	C	P	X=Special

3. Tolerances				5. Cutting edge length								
Tol. class	Tolerance +/- mm			For d dimension in mm								
				5,566	6,35	7,937	7,94	9,525	11,509	12,7	15,875	19,05
G	0,025	0,13	0,025	•	•	•		•	•	•	•	•
M	0,013	0,13	0,05	•	•		•	•				
	0,013	0,13	0,08							•		

6. Thickness	7. Insert with corner chamfers/nose radius	10. Internal designation
 02=2,38 mm 03 = 3,18 mm T3 = 3,97 mm 04 = 4,76 mm 05 = 5,56 mm	 nose radius 04 = 0,4 mm 08 = 0,8 mm 12 = 1,2 mm etc.	e.g. chipbreaker designation P1 = xx P2 = xx 85 = xx 86 = xx

Indexable inserts – Peripheral insert, type P1* for SD522, SD523, SD524, SD525, SD542, SD602

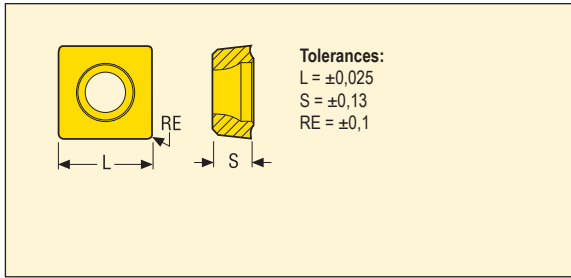

Size	Dimensions in mm		
	L	S	RE
06	6,35	2,38	0,40
07	7,94	3,18	0,80
09	9,53	3,97	0,80
11	11,51	3,97	0,80
12	12,70	4,76	0,80
15	15,88	5,56	1,20

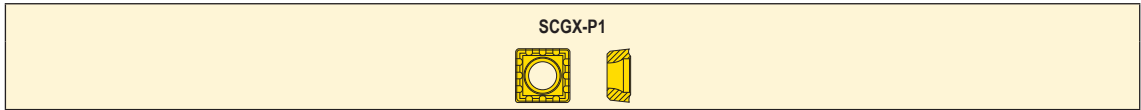

Inserts	Designation	Grades		
		T250D	DP2000	DP3000
SCGX-P1	SCGX060204-P1	00059712	02590849	02807362
	SCGX070308-P1	00059713	02590850	02807363
	SCGX09T308-P1	00059714	02590851	02807364
	SCGX11T308-P1	03136962	03136963	03136964
	SCGX120408-P1	00059715	02590852	02807365
	SCGX150512-P1	00059716	02590853	02807366

*Chipbreaker for low feed rates and for good surface finish in all materials

Indexable inserts – Peripheral insert, type P2** for SD522, SD523, SD524, SD525, SD542, SD602

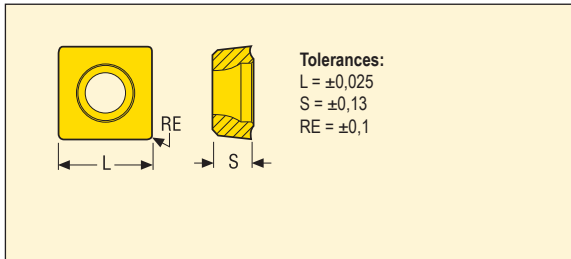

Size	Dimensions in mm		
	L	S	RE
05	5,56	2,38	0,40
06	6,35	2,38	0,40
07	7,94	3,18	0,80
09	9,53	3,97	0,80
11	11,51	3,97	0,80
12	12,70	4,76	0,80
15	15,88	5,56	1,20

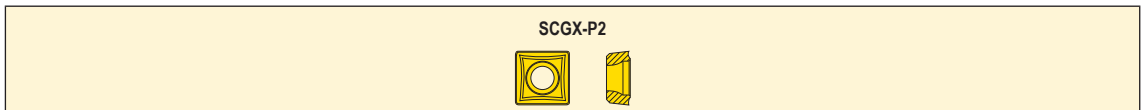

Inserts	Designation	Grades		
		T250D	DP2000	DP3000
SCGX-P2	SCGX050204-P2	00059711	02590854	02807356
	SCGX060204-P2	02526803	02590855	02807357
	SCGX070308-P2	02526787	02590856	02807358
	SCGX09T308-P2	02794476	02590857	02807359
	SCGX11T308-P2	03097760	03097761	03097762
	SCGX120408-P2	02794477	02590858	02807360
	SCGX150512-P2	02794478	02590859	02807361

**Chipbreaker for high feed rates in steel, stainless steel and cast iron

Stock standard. Subject to change refer to current price- and stock-list

Indexable inserts – Peripheral insert, type MP for SD522, SD523, SD524, SD525, SD542, SD602

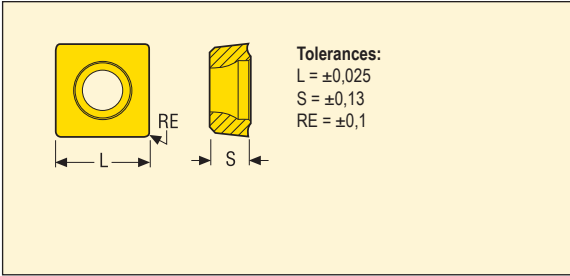

Size	Dimensions in mm		
	L	S	RE
05	5,56	2,38	0,40
06	6,35	6,35	0,40
07	7,94	3,18	0,80
09	9,53	3,97	0,80
11	11,51	3,97	0,80
12	12,70	4,76	0,80
15	15,88	5,56	1,20

SCGX-MP



Inserts	Designation	Grades	
		DS2050	
SCGX-MP			
	SCGX050204-MP	03134312	
	SCGX060204-MP	03134313	
	SCGX070308-MP	03134314	
	SCGX09T308-MP	03134315	
	SCGX11T308-MP	03134316	
	SCGX120408-MP	03134317	
	SCGX150512-MP	03134318	

Stock standard. Subject to change refer to current price- and stock-list

Indexable inserts – Centre insert, type C1 for SD522, SD523, SD524, SD525, SD542

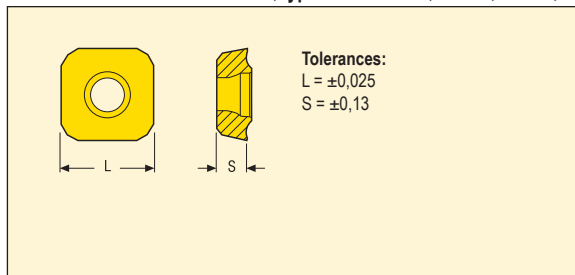

Size	Dimensions in mm	
	L	S
05	5,56	2,38
06	6,35	2,38
07	7,94	3,18
09	9,53	3,18
11	11,51	3,97
12	12,70	3,97
15	15,88	4,76
19	19,05	4,76

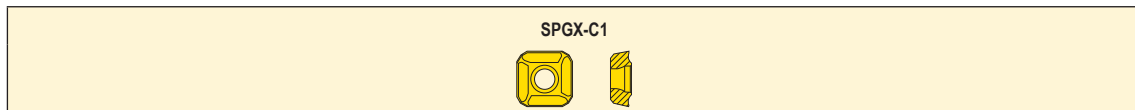

Inserts	Designation	Grades	
		T400D	DP3000
SPGX-C1	SPGX0502-C1	74077370	02807367
	SPGX0602-C1	74077371	02807368
	SPGX0703-C1	74077372	02807369
	SPGX0903-C1	74077373	02807370
	SPGX11T3-C1	74077374	02807371
	SPGX12T3-C1	74077375	02807372
	SPGX1504-C1	74077376	02807373
	SPGX1904-C1	74077377	02807374

Stock standard. Subject to change refer to current price- and stock-list

Indexable inserts – Centre insert, type MC for SD522, SD523, SD524, SD525, SD542

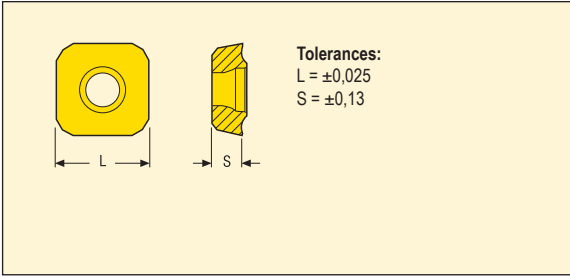

Size	Dimensions in mm	
	L	S
05	5,56	2,38
06	6,35	2,38
07	7,94	3,18
09	9,53	3,18
11	11,51	3,97
12	12,70	3,97
15	15,88	4,76
19	19,05	4,76

SPGX-MC



Inserts	Designation	Grades	
		DS4050	
SPGX-MC	SPGX0502-MC	03134319	
	SPGX0602-MC	03134320	
	SPGX0703-MC	03134321	
	SPGX0903-MC	03134322	
	SPGX11T3-MC	03134323	
	SPGX12T3-MC	03134324	
	SPGX1504-MC	03134325	
	SPGX1904-MC	03134326	

Stock standard. Subject to change refer to current price- and stock-list

Indexable inserts – Peripheral insert, type 85* for SD572

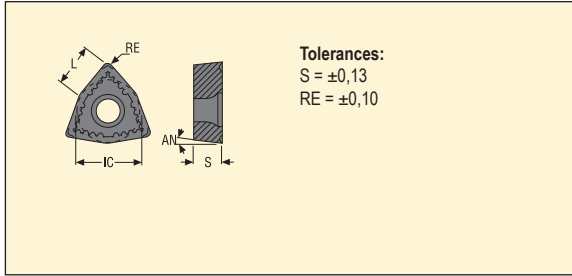

Size	Dimensions in mm			
	IC	L	S	RE
04	6,35	3,99	2,38	0,8
05	7,94	5,07	3,18	0,8
06	9,525	6,14	3,97	0,8
08	12,7	8,14	4,76	1,2

WCMX-85

Inserts	Designation	Grades	
		DF 3000	
WCMX-85			
	WCMX040208-85	02807375	
	WCMX050308-85	02807376	
	WCMX06T308-85	02807377	
	WCMX080412-85	02807378	

* Chipbreaker for low feed rates and for good surface finish in all materials.

Indexable inserts – Centre insert & Peripheral insert, type 86** for SD572

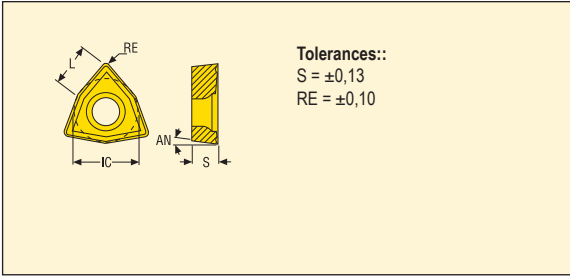

Size	Dimensions in mm			
	IC	L	S	RE
03	5,556	3,46	2,38	0,8
04	6,35	3,99	2,38	0,8
05	7,94	5,07	3,18	0,8
06	9,525	6,14	3,97	0,8
08	12,7	8,14	4,76	1,2



Inserts	Designation	Grades			
		T400D	DP2000	DP3000	
WCMX-86	WCMX030208-86	02506629	02899808	02807379	
	WCMX040208-86	02506638	02899809	02807380	
	WCMX050308-86	02506640	02899810	02807381	
	WCMX06T308-86	02506645	02899811	02807382	
	WCMX080412-86	02506646	02899812	02807383	

** Chipbreaker for high feed rates in steel, stainless steel and cast iron.

Stock standard. Subject to change refer to current price- and stock-list

Cutting data – SD522 Ø15-60 – Metric

SMG		f							v _c
		Ø 15,00-19,49	Ø 19,50-22,49	Ø 22,50-28,49	Ø 28,50-34,49	Ø 34,50-40,49	Ø 40,49-44,49	Ø 44,50-59,99	
P1	P1 DP2000	0,060	0,070	0,085	0,095	0,11	0,12	0,13	460
P2	P1 DP2000	0,060	0,070	0,085	0,10	0,11	0,12	0,13	450
P3	P2 DP3000	0,12	0,14	0,17	0,19	0,22	0,22	0,26	345
P4	P2 DP3000	0,12	0,13	0,16	0,19	0,22	0,22	0,26	220
P5	P2 DP3000	0,11	0,13	0,16	0,18	0,20	0,22	0,24	210
P6	P2 DP3000	0,11	0,13	0,16	0,18	0,20	0,22	0,24	235
P7	P2 DP3000	0,11	0,13	0,16	0,18	0,20	0,22	0,24	225
P8	P2 DP3000	0,12	0,14	0,17	0,19	0,22	0,22	0,26	210
P11	P2 DP3000	0,11	0,13	0,16	0,18	0,20	0,22	0,24	215
P12	P2 DP3000	0,075	0,090	0,11	0,12	0,14	0,15	0,17	130
M1	P2 DP3000	0,085	0,10	0,12	0,14	0,16	0,17	0,19	260
M2	P2 DP3000	0,080	0,090	0,11	0,13	0,14	0,15	0,17	210
M3	MP DS2050	0,065	0,075	0,090	0,10	0,12	0,13	0,14	160
M4	MP DS2050	0,055	0,065	0,080	0,090	0,10	0,11	0,12	140
M5	MP DS2050	0,055	0,065	0,080	0,090	0,10	0,11	0,12	115
K1	P2 DP2000	0,12	0,14	0,17	0,20	0,22	0,24	0,26	250
K2	P2 DP2000	0,11	0,13	0,16	0,18	0,20	0,22	0,24	215
K3	P2 DP2000	0,11	0,13	0,16	0,18	0,20	0,22	0,24	185
K4	P2 DP2000	0,11	0,13	0,16	0,18	0,20	0,22	0,24	175
K5	P2 DP2000	0,10	0,11	0,14	0,16	0,18	0,19	0,22	105
N1	P1 T250D	0,12	0,14	0,17	0,20	0,22	0,24	0,26	365
N2	P1 T250D	0,12	0,14	0,17	0,20	0,22	0,24	0,26	235
N3	P1 T250D	0,12	0,14	0,17	0,20	0,22	0,24	0,26	155
N11	P1 T250D	0,12	0,14	0,17	0,20	0,22	0,24	0,26	310
S1	MP DS2050	0,090	0,11	0,13	0,15	0,17	0,18	0,20	60
S2	MP DS2050	0,090	0,11	0,13	0,15	0,17	0,18	0,20	48
S3	MP DS2050	0,085	0,10	0,12	0,14	0,16	0,17	0,19	41
S11	MP DS2050	0,11	0,12	0,15	0,17	0,19	0,20	0,24	85
S12	MP DS2050	0,11	0,12	0,15	0,17	0,19	0,20	0,24	65
S13	MP DS2050	0,090	0,11	0,13	0,15	0,17	0,18	0,20	50
H3	P1 T250D	0,050	0,060	0,070	0,080	0,095	0,10	0,11	70
H5	P1 T250D	0,075	0,090	0,11	0,12	0,14	0,15	0,17	130
H7	P1 T250D	0,050	0,060	0,070	0,080	0,095	0,10	0,11	70
H8	P1 T250D	0,060	0,070	0,085	0,095	0,11	0,11	0,13	130
H11	P1 T250D	0,075	0,090	0,11	0,12	0,14	0,15	0,17	165
H12	P1 T250D	0,060	0,070	0,085	0,095	0,11	0,11	0,13	150
H21	P1 T250D	0,060	0,070	0,085	0,095	0,11	0,11	0,13	130

SMG = Seco material group

f = mm/rev

v_c = m/min

All cutting data are start values

Cutting data – SD522 Cutting speed – Metric

SMG	v _c			
	DP2000	DP3000	T250D	DS2050
P1	460	415	315	415
P2	450	405	305	405
P3	385	345	265	345
P4	285	220	140	—
P5	270	210	135	—
P6	305	235	150	—
P7	285	225	140	—
P8	270	210	135	—
P11	280	215	140	—
P12	165	130	80	—
M1	—	260	160	—
M2	—	210	130	—
M3	—	160	100	160
M4	—	120	75	140
M5	—	100	60	115
K1	250	235	—	—
K2	215	205	—	—
K3	185	175	—	—
K4	175	165	—	—
K5	105	100	—	—
N1	—	420	365	365
N2	—	270	235	235
N3	—	180	155	155
N11	—	350	310	310
S1	—	—	40	60
S2	—	—	30	48
S3	—	—	30	41
S11	—	—	80	85
S12	—	—	60	65
S13	—	—	46	50
H3	—	70	70	—
H5	—	130	130	—
H7	—	70	70	—
H8	—	130	130	—
H11	—	165	165	—
H12	—	75	150	—
H21	—	130	130	—

SMG = Seco material group

v_c = m/min

All cutting data are start values

Cutting data – SD523 Ø15-60 – Metric

SMG		f							v _c
		Ø 15,00-19,49	Ø 19,50-22,49	Ø 22,50-28,49	Ø 28,50-34,49	Ø 34,50-40,49	Ø 40,49-44,49	Ø 44,50-59,99	
P1	P1 DP2000	0,060	0,070	0,085	0,095	0,11	0,12	0,13	415
P2	P1 DP2000	0,060	0,070	0,085	0,10	0,11	0,12	0,13	405
P3	P2 DP3000	0,12	0,14	0,17	0,19	0,22	0,22	0,26	310
P4	P2 DP3000	0,12	0,13	0,16	0,19	0,22	0,22	0,26	190
P5	P2 DP3000	0,11	0,13	0,16	0,18	0,20	0,22	0,24	180
P6	P2 DP3000	0,11	0,13	0,16	0,18	0,20	0,22	0,24	200
P7	P2 DP3000	0,11	0,13	0,16	0,18	0,20	0,22	0,24	190
P8	P2 DP3000	0,12	0,14	0,17	0,19	0,22	0,22	0,26	180
P11	P2 DP3000	0,11	0,13	0,16	0,18	0,20	0,22	0,24	185
P12	P2 DP3000	0,075	0,090	0,11	0,12	0,14	0,15	0,17	110
M1	P2 DP3000	0,085	0,10	0,12	0,14	0,16	0,17	0,19	245
M2	P2 DP3000	0,080	0,090	0,11	0,13	0,14	0,15	0,17	195
M3	MP DS2050	0,065	0,075	0,090	0,10	0,12	0,13	0,14	150
M4	MP DS2050	0,055	0,065	0,080	0,090	0,10	0,11	0,12	120
M5	MP DS2050	0,055	0,065	0,080	0,090	0,10	0,11	0,12	100
K1	P2 DP2000	0,12	0,14	0,17	0,20	0,22	0,24	0,26	225
K2	P2 DP2000	0,11	0,13	0,16	0,18	0,20	0,22	0,24	195
K3	P2 DP2000	0,11	0,13	0,16	0,18	0,20	0,22	0,24	165
K4	P2 DP2000	0,11	0,13	0,16	0,18	0,20	0,22	0,24	160
K5	P2 DP2000	0,10	0,11	0,14	0,16	0,18	0,19	0,22	95
N1	P1 T250D	0,12	0,14	0,17	0,20	0,22	0,24	0,26	310
N2	P1 T250D	0,12	0,14	0,17	0,20	0,22	0,24	0,26	200
N3	P1 T250D	0,12	0,14	0,17	0,20	0,22	0,24	0,26	135
N11	P1 T250D	0,12	0,14	0,17	0,20	0,22	0,24	0,26	260
S1	MP DS2050	0,090	0,11	0,13	0,15	0,17	0,18	0,20	55
S2	MP DS2050	0,090	0,11	0,13	0,15	0,17	0,18	0,20	43
S3	MP DS2050	0,085	0,10	0,12	0,14	0,16	0,17	0,19	37
S11	MP DS2050	0,11	0,12	0,15	0,17	0,19	0,20	0,24	75
S12	MP DS2050	0,11	0,12	0,15	0,17	0,19	0,20	0,24	60
S13	MP DS2050	0,090	0,11	0,13	0,15	0,17	0,18	0,20	45
H3	P1 T250D	0,050	0,060	0,070	0,080	0,095	0,10	0,11	60
H5	P1 T250D	0,075	0,090	0,11	0,12	0,14	0,15	0,17	110
H7	P1 T250D	0,050	0,060	0,070	0,080	0,095	0,10	0,11	60
H8	P1 T250D	0,060	0,070	0,085	0,095	0,11	0,11	0,13	110
H11	P1 T250D	0,075	0,090	0,11	0,12	0,14	0,15	0,17	140
H12	P1 T250D	0,060	0,070	0,085	0,095	0,11	0,11	0,13	130
H21	P1 T250D	0,060	0,070	0,085	0,095	0,11	0,11	0,13	110

SMG = Seco material group

f = mm/rev

v_c = m/min

All cutting data are start values

Cutting data – SD523 Cutting speed – Metric

SMG	v _c			
	DP2000	DP3000	T250D	DS2050
P1	415	370	265	370
P2	405	360	260	360
P3	345	310	225	310
P4	230	190	120	—
P5	220	180	115	—
P6	250	200	130	—
P7	235	190	120	—
P8	220	180	115	—
P11	225	185	115	—
P12	135	110	70	—
M1	—	245	135	—
M2	—	195	110	—
M3	—	150	85	150
M4	—	115	65	120
M5	—	95	55	100
K1	225	215	—	—
K2	195	185	—	—
K3	165	160	—	—
K4	160	150	—	—
K5	95	90	—	—
N1	—	360	310	310
N2	—	230	200	200
N3	—	155	135	135
N11	—	300	260	260
S1	—	—	34	55
S2	—	—	25	43
S3	—	—	25	37
S11	—	—	65	75
S12	—	—	50	60
S13	—	—	39	45
H3	—	60	60	—
H5	—	115	110	—
H7	—	60	60	—
H8	—	115	110	—
H11	—	145	140	—
H12	—	65	130	—
H21	—	115	110	—

SMG = Seco material group

v_c = m/min

All cutting data are start values

Cutting data – SD524 Ø17-60 – Metric

SMG		f							V _c
		Ø 17,00-19,49	Ø 19,50-22,49	Ø 22,50-28,49	Ø 28,50-34,49	Ø 34,50-40,49	Ø 40,49-44,49	Ø 44,50-59,99	
P1	P1 DP2000	0,060	0,070	0,085	0,095	0,11	0,12	0,13	380
P2	P1 DP2000	0,060	0,070	0,085	0,10	0,11	0,12	0,13	370
P3	P2 DP3000	0,12	0,14	0,17	0,19	0,22	0,22	0,26	285
P4	P2 DP3000	0,12	0,13	0,16	0,19	0,22	0,22	0,26	165
P5	P2 DP3000	0,11	0,13	0,16	0,18	0,20	0,22	0,24	160
P6	P2 DP3000	0,11	0,13	0,16	0,18	0,20	0,22	0,24	180
P7	P2 DP3000	0,11	0,13	0,16	0,18	0,20	0,22	0,24	170
P8	P2 DP3000	0,12	0,14	0,17	0,19	0,22	0,22	0,26	160
P11	P2 DP3000	0,11	0,13	0,16	0,18	0,20	0,22	0,24	165
P12	P2 DP3000	0,075	0,090	0,11	0,12	0,14	0,15	0,17	95
M1	P2 DP3000	0,085	0,10	0,12	0,14	0,16	0,17	0,19	235
M2	P2 DP3000	0,080	0,090	0,11	0,13	0,14	0,15	0,17	190
M3	MP DS2050	0,065	0,075	0,090	0,10	0,12	0,13	0,14	145
M4	MP DS2050	0,055	0,065	0,080	0,090	0,10	0,11	0,12	105
M5	MP DS2050	0,055	0,065	0,080	0,090	0,10	0,11	0,12	90
K1	P2 DP2000	0,12	0,14	0,17	0,20	0,22	0,24	0,26	210
K2	P2 DP2000	0,11	0,13	0,16	0,18	0,20	0,22	0,24	180
K3	P2 DP2000	0,11	0,13	0,16	0,18	0,20	0,22	0,24	155
K4	P2 DP2000	0,11	0,13	0,16	0,18	0,20	0,22	0,24	145
K5	P2 DP2000	0,10	0,11	0,14	0,16	0,18	0,19	0,22	85
N1	P1 T250D	0,12	0,14	0,17	0,20	0,22	0,24	0,26	270
N2	P1 T250D	0,12	0,14	0,17	0,20	0,22	0,24	0,26	175
N3	P1 T250D	0,12	0,14	0,17	0,20	0,22	0,24	0,26	115
N11	P1 T250D	0,12	0,14	0,17	0,20	0,22	0,24	0,26	230
S1	MP DS2050	0,090	0,11	0,13	0,15	0,17	0,18	0,20	48
S2	MP DS2050	0,090	0,11	0,13	0,15	0,17	0,18	0,20	39
S3	MP DS2050	0,085	0,10	0,12	0,14	0,16	0,17	0,19	33
S11	MP DS2050	0,11	0,12	0,15	0,17	0,19	0,20	0,24	70
S12	MP DS2050	0,11	0,12	0,15	0,17	0,19	0,20	0,24	55
S13	MP DS2050	0,090	0,11	0,13	0,15	0,17	0,18	0,20	41
H3	P1 T250D	0,050	0,060	0,070	0,080	0,095	0,10	0,11	50
H5	P1 T250D	0,075	0,090	0,11	0,12	0,14	0,15	0,17	95
H7	P1 T250D	0,050	0,060	0,070	0,080	0,095	0,10	0,11	50
H8	P1 T250D	0,060	0,070	0,085	0,095	0,11	0,11	0,13	95
H11	P1 T250D	0,075	0,090	0,11	0,12	0,14	0,15	0,17	125
H12	P1 T250D	0,060	0,070	0,085	0,095	0,11	0,11	0,13	110
H21	P1 T250D	0,060	0,070	0,085	0,095	0,11	0,11	0,13	95

SMG = Seco material group
 f = mm/rev
 v_c = m/min
 All cutting data are start values

Cutting data – SD524 Cutting speed – Metric

SMG	v _c			
	DP2000	DP3000	T250D	DS2050
P1	380	340	230	340
P2	370	330	225	330
P3	320	285	195	285
P4	195	165	105	—
P5	185	160	100	—
P6	210	180	110	—
P7	195	170	105	—
P8	185	160	100	—
P11	190	165	100	—
P12	110	95	60	—
M1	—	235	120	—
M2	—	190	95	—
M3	—	145	75	145
M4	—	110	55	105
M5	—	90	46	90
K1	210	200	—	—
K2	180	170	—	—
K3	155	145	—	—
K4	145	140	—	—
K5	85	85	—	—
N1	—	315	270	270
N2	—	205	175	175
N3	—	135	115	115
N11	—	265	230	230
S1	—	—	29	48
S2	—	—	22	39
S3	—	—	22	33
S11	—	—	55	70
S12	—	—	44	55
S13	—	—	34	41
H3	—	55	50	—
H5	—	100	95	—
H7	—	55	50	—
H8	—	100	95	—
H11	—	125	125	—
H12	—	55	110	—
H21	—	100	95	—

SMG = Seco material group

v_c= m/min

All cutting data are start values

Cutting data – SD525 Ø19-45 – Metric

SMG		f					v _c
		Ø 19,50-22,49	Ø 22,50-28,49	Ø 28,50-34,49	Ø 34,50-40,49	Ø 40,49-45,00	
P1	P2 DP3000	0,070	0,085	0,095	0,11	0,12	320
P2	P2 DP3000	0,070	0,085	0,10	0,11	0,12	310
P3	P2 DP3000	0,14	0,17	0,19	0,22	0,22	265
P4	P2 DP3000	0,13	0,16	0,19	0,22	0,22	150
P5	P2 DP3000	0,13	0,16	0,18	0,20	0,22	140
P6	P2 DP3000	0,13	0,16	0,18	0,20	0,22	160
P7	P2 DP3000	0,13	0,16	0,18	0,20	0,22	150
P8	P2 DP3000	0,14	0,17	0,19	0,22	0,22	140
P11	P2 DP3000	0,13	0,16	0,18	0,20	0,22	145
P12	P2 DP3000	0,090	0,11	0,12	0,14	0,15	85
M1	P2 DP3000	0,10	0,12	0,14	0,16	0,17	225
M2	P2 DP3000	0,090	0,11	0,13	0,14	0,15	180
M3	MP DS2050	0,075	0,090	0,10	0,12	0,13	140
M4	MP DS2050	0,065	0,080	0,090	0,10	0,11	95
M5	MP DS2050	0,065	0,080	0,090	0,10	0,11	80
K1	P2 DP3000	0,14	0,17	0,20	0,22	0,24	185
K2	P2 DP3000	0,13	0,16	0,18	0,20	0,22	160
K3	P2 DP3000	0,13	0,16	0,18	0,20	0,22	135
K4	P2 DP3000	0,13	0,16	0,18	0,20	0,22	130
K5	P2 DP3000	0,11	0,14	0,16	0,18	0,19	80
N1	P1 T250D	0,14	0,17	0,20	0,22	0,24	240
N2	P1 T250D	0,14	0,17	0,20	0,22	0,24	155
N3	P1 T250D	0,14	0,17	0,20	0,22	0,24	100
N11	P1 T250D	0,14	0,17	0,20	0,22	0,24	200
S1	MP DS2050	0,11	0,13	0,15	0,17	0,18	44
S2	MP DS2050	0,11	0,13	0,15	0,17	0,18	36
S3	MP DS2050	0,10	0,12	0,14	0,16	0,17	31
S11	MP DS2050	0,12	0,15	0,17	0,19	0,20	65
S12	MP DS2050	0,12	0,15	0,17	0,19	0,20	49
S13	MP DS2050	0,11	0,13	0,15	0,17	0,18	38
H3	P1 T250D	0,060	0,070	0,085	0,095	0,10	46
H5	P1 T250D	0,090	0,11	0,12	0,14	0,15	85
H7	P1 T250D	0,060	0,070	0,085	0,095	0,10	46
H8	P1 T250D	0,070	0,085	0,095	0,11	0,11	85
H11	P1 T250D	0,090	0,11	0,12	0,14	0,15	110
H12	P1 T250D	0,070	0,085	0,095	0,11	0,11	100
H21	P1 T250D	0,070	0,085	0,095	0,11	0,11	85

SMG = Seco material group

f = mm/rev

v_c = m/min

All cutting data are start values

Cutting data – SD525 Cutting speed – Metric

SMG	v _c			
	DP2000	DP3000	T250D	DS2050
P1	355	320	205	320
P2	345	310	200	310
P3	295	265	170	265
P4	165	150	90	—
P5	155	140	90	—
P6	175	160	100	—
P7	165	150	95	—
P8	155	140	90	—
P11	160	145	90	—
P12	95	85	55	—
M1	—	225	105	—
M2	—	180	85	—
M3	—	140	65	140
M4	—	105	49	95
M5	—	85	41	80
K1	195	185	—	—
K2	170	160	—	—
K3	145	135	—	—
K4	140	130	—	—
K5	80	80	—	—
N1	—	285	240	240
N2	—	185	155	155
N3	—	120	100	100
N11	—	235	200	200
S1	—	—	26	44
S2	—	—	20	36
S3	—	—	20	31
S11	—	—	50	65
S12	—	—	39	49
S13	—	—	30	38
H3	—	48	46	—
H5	—	90	85	—
H7	—	48	46	—
H8	—	90	85	—
H11	—	115	110	—
H12	—	50	100	—
H21	—	90	85	—

SMG = Seco material group

v_c= m/min

All cutting data are start values

Cutting data – SD542 Ø60-85

SMG		f		v _c
		Ø60,00-65,00	Ø70,00-85,00	
P1	P2 DP3000	0,095	0,12	390
P2	P2 DP3000	0,10	0,12	380
P3	P2 DP3000	0,19	0,22	325
P4	P2 DP3000	0,19	0,22	205
P5	P2 DP3000	0,18	0,22	195
P6	P2 DP3000	0,18	0,22	220
P7	P2 DP3000	0,18	0,22	205
P8	P2 DP3000	0,19	0,22	195
P11	P2 DP3000	0,18	0,22	200
P12	P2 DP3000	0,12	0,15	120
M1	P2 DP3000	0,14	0,17	250
M2	P2 DP3000	0,13	0,15	205
M3	P1 T250D	0,10	0,12	90
M4	P1 T250D	0,090	0,11	70
M5	P1 T250D	0,090	0,11	55
K1	P2 DP3000	0,20	0,24	225
K2	P2 DP3000	0,18	0,22	195
K3	P2 DP3000	0,18	0,22	165
K4	P2 DP3000	0,18	0,22	160
K5	P2 DP3000	0,16	0,19	95
N1	P1 T250D	0,20	0,24	335
N2	P1 T250D	0,20	0,24	215
N3	P1 T250D	0,20	0,24	145
N11	P1 T250D	0,20	0,24	285
S1	P1 T250D	0,13	0,15	37
S2	P1 T250D	0,13	0,15	27
S3	P1 T250D	0,12	0,14	27
S11	P1 T250D	0,15	0,18	70
S12	P1 T250D	0,15	0,18	55
S13	P1 T250D	0,13	0,15	43
H3	P1 T250D	0,080	0,10	65
H5	P1 T250D	0,12	0,15	120
H7	P1 T250D	0,080	0,10	65
H8	P1 T250D	0,095	0,11	120
H11	P1 T250D	0,12	0,15	155
H12	P1 T250D	0,095	0,11	140
H21	P1 T250D	0,095	0,11	120

SMG = Seco material group
 f = mm/rev
 v_c = m/min
 All cutting data are start values

Cutting data – SD542 Cutting speed

SMG	v _c			
	DP2000	DP3000	T250D	DS2050
P1	435	390	290	390
P2	425	380	280	380
P3	365	325	240	325
P4	255	205	130	—
P5	245	195	125	—
P6	275	220	140	—
P7	260	205	130	—
P8	245	195	125	—
P11	250	200	125	—
P12	150	120	75	—
M1	—	250	150	—
M2	—	205	120	—
M3	—	155	90	155
M4	—	115	70	130
M5	—	95	55	105
K1	235	225	—	—
K2	205	195	—	—
K3	175	165	—	—
K4	165	160	—	—
K5	100	95	—	—
N1	—	390	335	335
N2	—	250	215	215
N3	—	165	145	145
N11	—	325	285	285
S1	—	—	37	55
S2	—	—	27	45
S3	—	—	27	39
S11	—	—	70	80
S12	—	—	55	60
S13	—	—	43	48
H3	—	65	65	—
H5	—	120	120	—
H7	—	65	65	—
H8	—	120	120	—
H11	—	155	155	—
H12	—	70	140	—
H21	—	120	120	—

SMG = Seco material group

v_c = m/min

All cutting data are start values

Cutting data – SD572 Ø15-52

SMG		f						v _c
		Ø15,00-17,00	Ø18,00-20,00	Ø21,00-24,00	Ø25,00-32,00	Ø33,00-36,00	Ø37,00-52,00	
P1	85 DP3000	0,042	0,042	0,048	0,060	0,070	0,085	310
P2	85 DP3000	0,042	0,042	0,050	0,060	0,070	0,085	305
P3	86 DP3000	0,12	0,12	0,13	0,17	0,19	0,22	260
P4	86 DP3000	0,11	0,11	0,13	0,16	0,19	0,22	230
P5	86 DP3000	0,11	0,11	0,13	0,16	0,18	0,22	220
P6	86 DP3000	0,11	0,11	0,13	0,16	0,18	0,22	245
P7	86 DP3000	0,11	0,11	0,13	0,16	0,18	0,22	235
P8	86 DP3000	0,12	0,12	0,13	0,17	0,19	0,22	220
P11	86 DP3000	0,11	0,11	0,13	0,16	0,18	0,22	225
P12	86 DP3000	0,075	0,075	0,085	0,11	0,12	0,15	135
M1	86 DP3000	0,075	0,075	0,085	0,11	0,12	0,15	235
M2	86 DP3000	0,070	0,070	0,080	0,10	0,11	0,14	190
M3	85 DP3000	0,034	0,034	0,040	0,048	0,055	0,070	145
M4	85 DP3000	0,030	0,030	0,034	0,042	0,050	0,060	110
M5	85 DP3000	0,030	0,030	0,034	0,042	0,050	0,060	90
K1	86 DP3000	0,12	0,12	0,14	0,17	0,20	0,24	180
K2	86 DP3000	0,11	0,11	0,13	0,16	0,18	0,22	155
K3	86 DP3000	0,11	0,11	0,13	0,16	0,18	0,22	130
K4	86 DP3000	0,11	0,11	0,13	0,16	0,18	0,22	125
K5	86 DP3000	0,10	0,10	0,11	0,14	0,16	0,19	75
S1	85 DP3000	0,055	0,055	0,060	0,075	0,090	0,11	40
S2	85 DP3000	0,055	0,055	0,060	0,075	0,090	0,11	30
S3	85 DP3000	0,050	0,050	0,060	0,070	0,085	0,10	30
S11	85 DP3000	0,060	0,060	0,070	0,090	0,10	0,12	80
S12	85 DP3000	0,060	0,060	0,070	0,090	0,10	0,12	60
S13	85 DP3000	0,055	0,055	0,060	0,075	0,090	0,11	47
H3	86 DP3000	0,050	0,050	0,060	0,070	0,085	0,10	80
H5	86 DP3000	0,075	0,075	0,085	0,11	0,12	0,15	150
H7	86 DP3000	0,050	0,050	0,060	0,070	0,085	0,10	80
H8	86 DP3000	0,060	0,060	0,065	0,085	0,095	0,11	150
H11	86 DP3000	0,075	0,075	0,085	0,11	0,12	0,15	195
H12	86 DP3000	0,060	0,060	0,065	0,085	0,095	0,11	80
H21	86 DP3000	0,060	0,060	0,065	0,085	0,095	0,11	150

SMG = Seco material group

f = mm/rev

v_c = m/min

All cutting data are start values

Cutting data – SD572 Cutting speed

SMG	v_c
	DP2000
P1	375
P2	365
P3	315
P4	280
P5	265
P6	300
P7	280
P8	265
P11	275
P12	160
M1	285
M2	230
M3	175
M4	130
M5	110
K1	215
K2	185
K3	160
K4	150
K5	90
S1	—
S2	—
S3	—
S11	—
S12	—
S13	—
H3	80
H5	150
H7	80
H8	150
H11	195
H12	95
H21	150

SMG = Seco material group

v_c = m/min

All cutting data are start values

Cutting data – SD602 Ø60-160

SMG		f					v _c
		Ø60,00-69,99	Ø70,00-91,99	Ø92,00-110,99	Ø111,00-134,99	Ø135,00-160,00	
P1	P2 DP3000	0,085	0,095	0,12	0,13	0,12	295
P2	P2 DP3000	0,085	0,10	0,12	0,13	0,12	285
P3	P2 DP3000	0,17	0,19	0,22	0,26	0,22	245
P4	P2 DP3000	0,16	0,19	0,22	0,26	0,22	130
P5	P2 DP3000	0,16	0,18	0,22	0,24	0,22	125
P6	P2 DP3000	0,16	0,18	0,22	0,24	0,22	140
P7	P2 DP3000	0,16	0,18	0,22	0,24	0,22	135
P8	P2 DP3000	0,17	0,19	0,22	0,26	0,22	125
P11	P2 DP3000	0,16	0,18	0,22	0,24	0,22	130
P12	P2 DP3000	0,11	0,12	0,15	0,17	0,15	75
M1	P2 DP3000	0,12	0,14	0,17	0,19	0,17	215
M2	P2 DP3000	0,11	0,13	0,15	0,17	0,15	175
M3	P1 DP3000	0,090	0,10	0,12	0,14	0,12	135
M4	P1 DP3000	0,075	0,090	0,11	0,12	0,11	100
M5	P1 DP3000	0,075	0,090	0,11	0,12	0,11	85
K1	P2 DP3000	0,17	0,20	0,24	0,26	0,24	175
K2	P2 DP3000	0,16	0,18	0,22	0,24	0,22	150
K3	P2 DP3000	0,16	0,18	0,22	0,24	0,22	130
K4	P2 DP3000	0,16	0,18	0,22	0,24	0,22	120
K5	P2 DP3000	0,14	0,16	0,19	0,22	0,19	75
H3	P2 DP3000	0,070	0,080	0,10	0,11	0,10	42
H5	P2 DP3000	0,11	0,12	0,15	0,17	0,15	80
H7	P2 DP3000	0,070	0,080	0,10	0,11	0,10	42
H8	P2 DP3000	0,085	0,095	0,11	0,13	0,11	80
H11	P2 DP3000	0,11	0,12	0,15	0,17	0,15	100
H12	P2 DP3000	0,085	0,095	0,11	0,13	0,11	45
H21	P2 DP3000	0,085	0,095	0,11	0,13	0,11	80

SMG = Seco material group
 f = mm/rev
 v_c = m/min
 All cutting data are start values

Cutting data – SD602 Cutting speed

SMG	v _c	
	T250D	DS2050
P1	180	295
P2	175	285
P3	150	245
P4	80	—
P5	75	—
P6	85	—
P7	80	—
P8	75	—
P11	80	—
P12	46	—
M1	90	—
M2	75	—
M3	55	135
M4	43	85
M5	36	70
K1	—	—
K2	—	—
K3	—	—
K4	—	—
K5	—	—
H3	40	—
H5	75	—
H7	40	—
H8	75	—
H11	95	—
H12	85	—
H21	75	—

SMG = Seco material group

v_c = m/min

All cutting data are start values

Custom design – No waiting for quotations! Price and delivery time available instantly!

A well defined strategy has been created for the total process for custom-made drills from quotation to finished drill. You can now design your own customised Perfomax® drill using the Custom Design software.

The concept gives you a number of advantages:

- No waiting for quotations! price and delivery time available instantly
- Directly visualises your needs. No risk of misunderstandings
- Short delivery time



CUSTOM DESIGN

Drilling >> perfoMAX® - SD70 - SD54 >> Single Diameter >> Chamfer
Feedback

Back
Start Page
English

[Print this page](#)

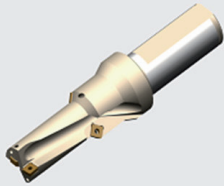
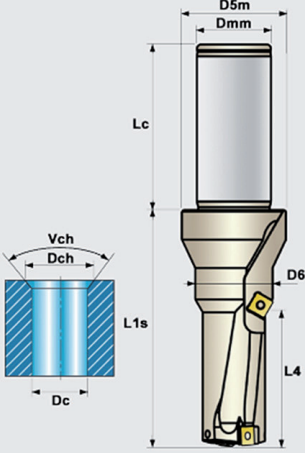
Step 1: Tool Specification
Step 2: Request for Quotation

	Min	Max	
Dc	15	60	42.5
L4	42.5	212.5	175.2
Vch	70	160	132
Dch	42.5	60.8	51.3
Type of shank	ISO 9766 (R7)		
Shank size	40		
L1s (±0.5)	210.2	247.5	222
Lc			68
D5m			59
Dmm (h6)			40
D6			61.4

Previous
Next

Spare Parts / Inserts

Note Inserts have to be ordered separately

Designation
SD509-A31-42.5-6791950

Delivery Time
Quantity: Get data

Please contact your local Seco representative for more information.

Different types of custom drills – Detailed information can be found in the Custom Design software

A1. Single diameter

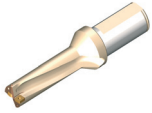

A1. Drill dia 15-60

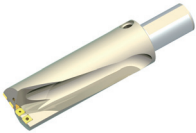

A1. Drill dia 60-110

A2. Reinforced



A3. Chamfer

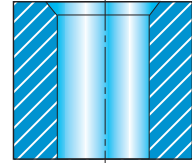

A4. Face

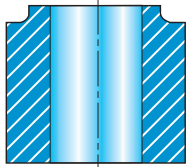
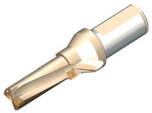

A5. Face with chamfer

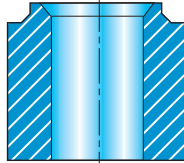
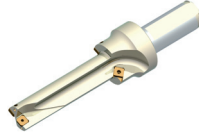

A6. Straight flutes

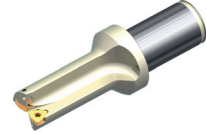

B1. Counterbore

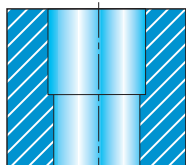

B2. Counterbore and chamfer

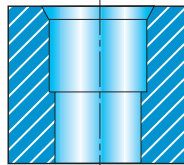

B3. Step

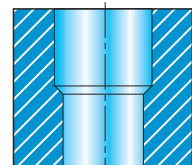
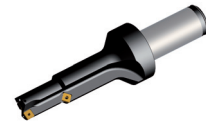

Different types of custom drills – Detailed information can be found in the Custom Design software

B4. Step and chamfer

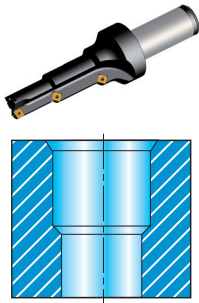

B5. Counterbore and chamfer

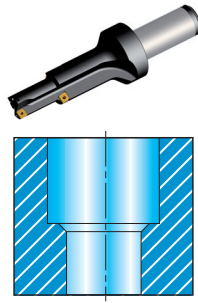

B6. Counterbore with chamfers

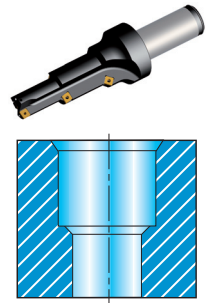

E1. Core drill single diameter

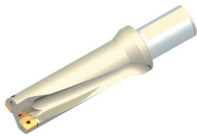

E2. Core drill reinforced

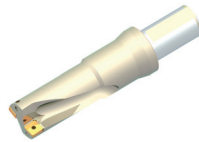

F1. Drill heads
(With pilot drill)



Machining data – Power consumption, coolant volume requirement and force graphs

The values in the graphs vary with e.g., cutting data, material, with a machine efficiency of 80%.
The graphs below are valid for SMG P5-P6 and cutting speed 200 m/min.

Feed force

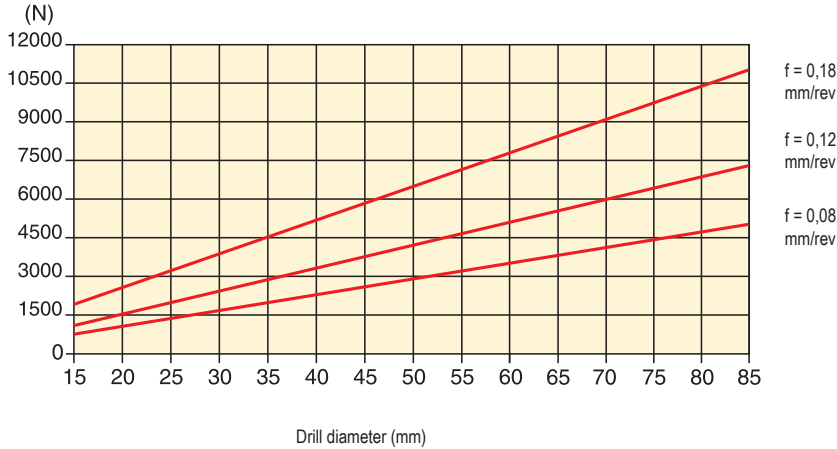

Net power consumption

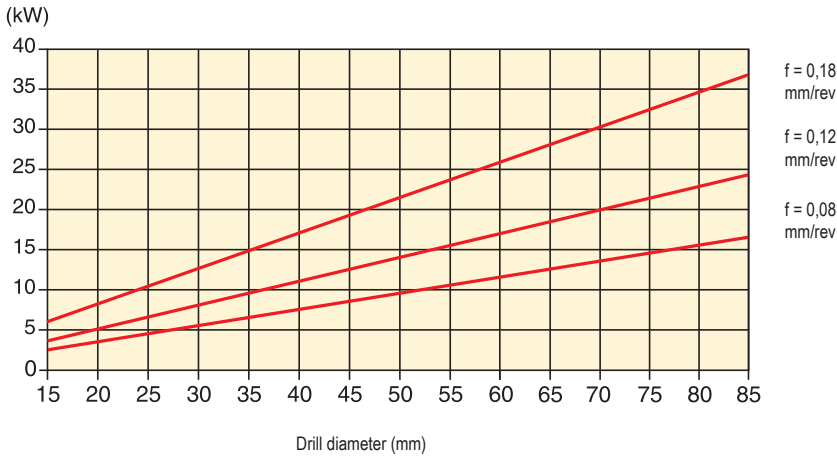

Drilling torque

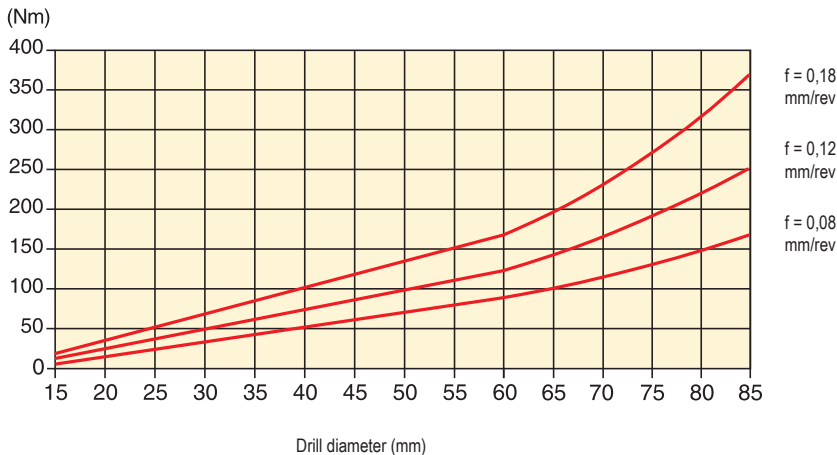

Machining data – Coolant volume requirement

(litres/min)

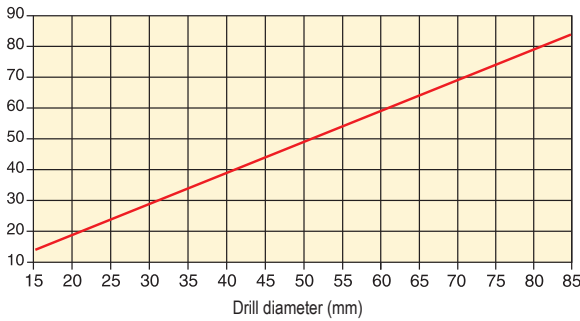

Coolant pressure requirement

Drilling depth	Recommended pressure (bar)		
	Drill diameter		
	15–25	> 25–40	> 40
< 3 x D	6	4,5	3
≥ 3 x D	12	9	6

Drilling of stacked materials

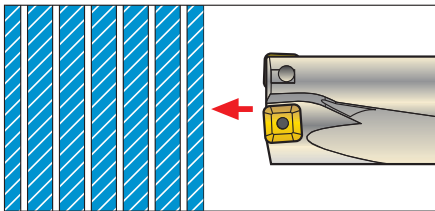

Drilling of stacked materials with no air gaps between the layers, (max 0,2 mm), can be done with SD523 3 x D and the SD542 2,5 x D drill. The component must be securely fixed so no flexing occurs when breaking through each layer.

Cutting data and insert recommendations for drilling of stacked materials

Insert geometry:

Centre insert: SPGX-C1

Periph insert: SCGX-P2

Carbide grade:

Centre insert: T400D

Periph insert: DP3000

Cutting speed: See recommendations for DP3000 carbide grade

Feed/rev: See recommendations for P2 geometry

If a problem occurs when breaking through each layer, reduce the feed/rev by 30-50%.

Caution!

The disc produced when the drill breaks through can be ejected at high speed when using the drill as a stationary tool, (rotating workpiece). It is most important to ensure that the machine is adequately guarded to ensure operator safety.

Set up

Hole diameter adjustment and set-up recommendation

The insert drills can be displaced off-centre to achieve a smaller or larger hole diameter than the actual drill.

For measurement see 'Radial adjustment' in the tool data table in the catalogue pages.

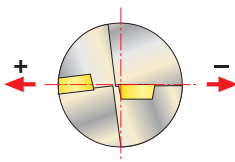

Rotating

Seco's adjustable holder is recommended for precision hole diameter IT10 setting when using SD522 and SD523, 3 x D as rotating drills.

Stationary

When mounting the drill make sure the cutting edges are parallel with the guide ways of the cross slide and that the drill centre line and workpiece centre line align. To achieve a larger hole diameter, displace the drill so that the periphery insert moves away from the workpiece centre line.

Machining data SD602 – Power consumption, coolant volume requirement and force graphs

The values in the graphs vary with e.g., cutting data, material, with a machine efficiency of 80%.
The graphs below are valid for SMG P5-P6 and cutting speed 200 m/min.

Feed force

(N)

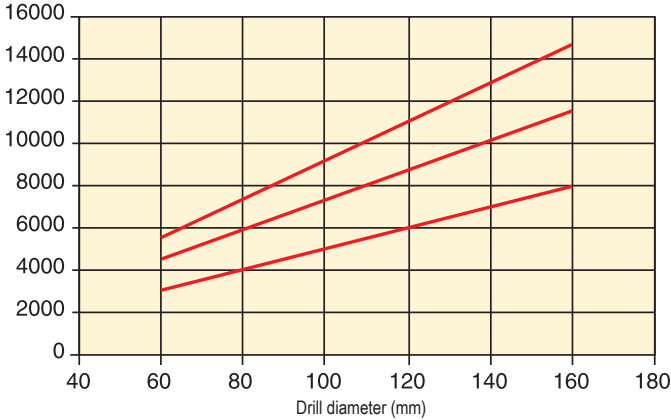

f = 0,18
mm/rev

f = 0,12
mm/rev

f = 0,08
mm/rev

Net power consumption

(kW)

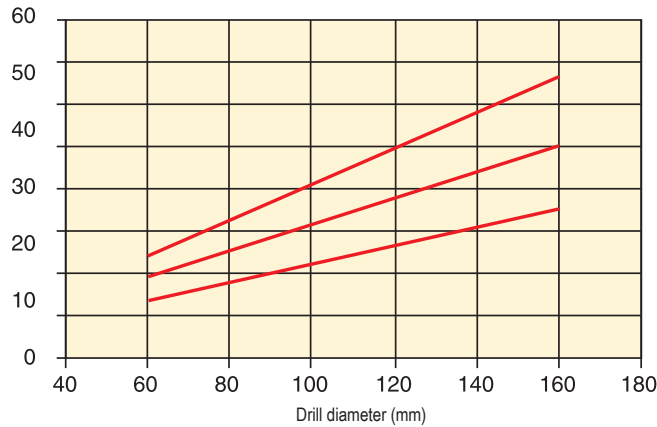

f = 0,18
mm/rev

f = 0,12
mm/rev

f = 0,08
mm/rev

Drilling torque

(Nm)

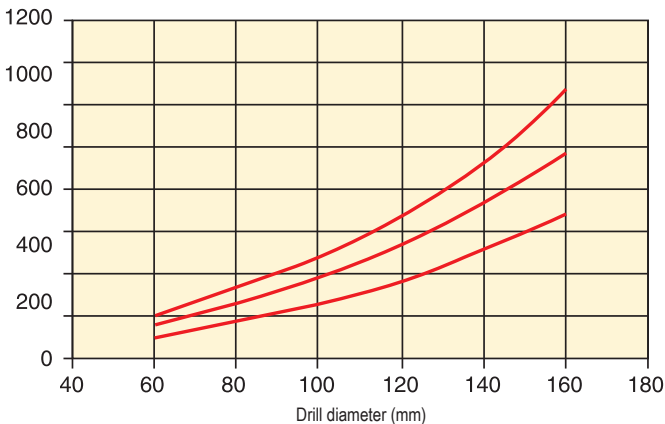

f = 0,18
mm/rev

f = 0,12
mm/rev

f = 0,08
mm/rev

Machining data SD602 – Coolant volume requirement
(litres/min)

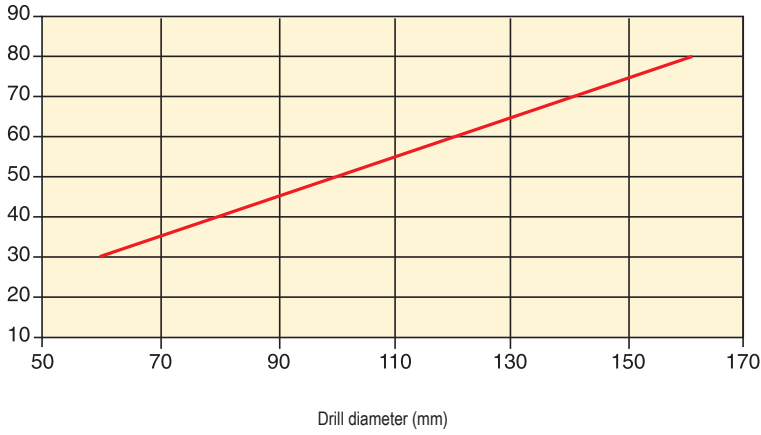

Methods

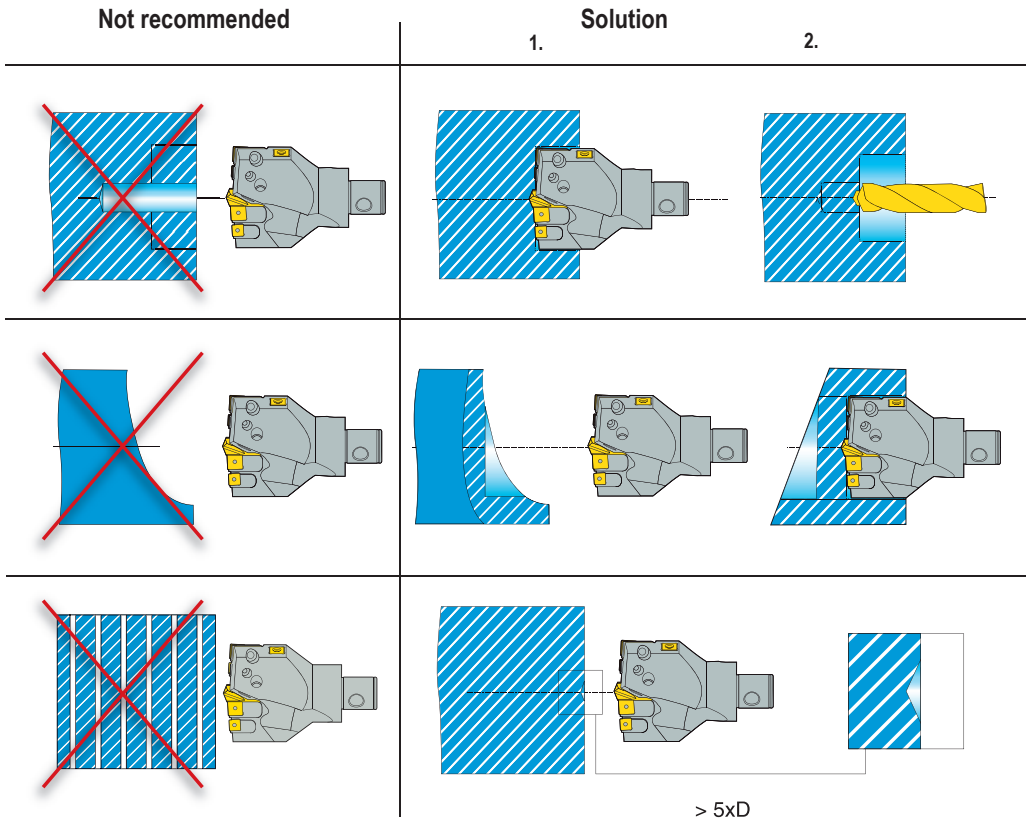

Versatility

1. Hole with angled entrance
2. Boring
3. Drilling across an existing hole
4. Drilling and plunging
5. Drilling and milling countersink by circular interpolation
6. Plunging

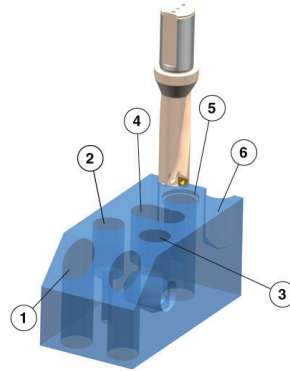

Recommendations:

- 2 x D and 3 x D drills (SD522, SD523)
- Reduce the feed ~ 50% when the drill is not fully engaged
- Use grade DP3000
- Use -P2 chipbreaker

Multiple choice in non rotating operations:

1. Drilling
2. Boring / Conical hole
3. Chamfering

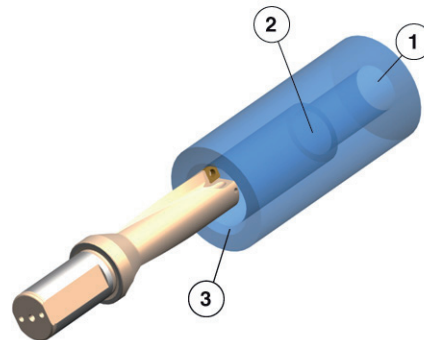

Troubleshooting

Vibrations

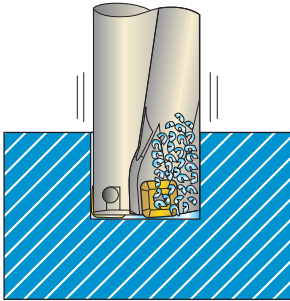

- Check mounting of drill
- Check mounting of workpiece
- Increase feed. If a very soft material, reduce feed and increase speed
- Reduce the cutting speed

Insufficient torque

- Reduce feed
- Choose a geometry with harder chipbreaking for lower feeds

Insufficient power

- Reduce cutting speed
- Reduce feed
- Choose a geometry with harder chipbreaking for lower feeds. (SCGX-P1)

Chip Jamming Problems

Chip jamming problems due to long chips

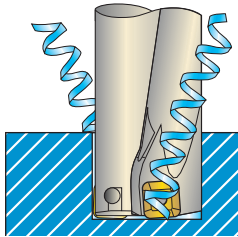

- Increase feed. If a very soft material, reduce feed and increase speed
- Choose a geometry with harder chipbreaking for lower feeds. (SCGX-P1)

Chip jamming problems despite short chips

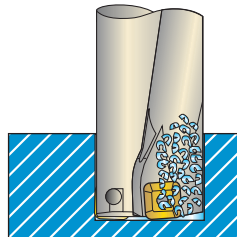

- Increase coolant pressure/volume
- Reduce cutting speed

Rapid flank wear on pilot drill

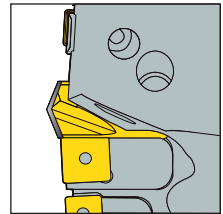

- Reduce the cutting speed
- Increase coolant concentration

Tool life problems

Chipping of periphery insert

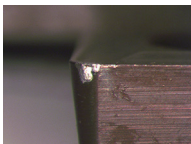

- Reduce entrance feed
- Choose a tougher grade
- Choose a geometry with softer chipbreaking for higher feeds (SCGX-P2)
- Reduce feed
- Reduce cutting speed

Chipping of centre insert



- Check mounting of drill
- Check mounting of workpiece
- Reduce entrance feed
- Increase feed
- Reduce cutting speed

Too fast flank wear on periphery insert

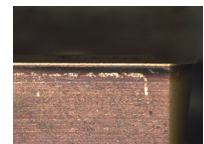

- Reduce cutting speed
- Increase coolant pressure volume
- Choose a more wear resistant grade

Adjustable holders for drills

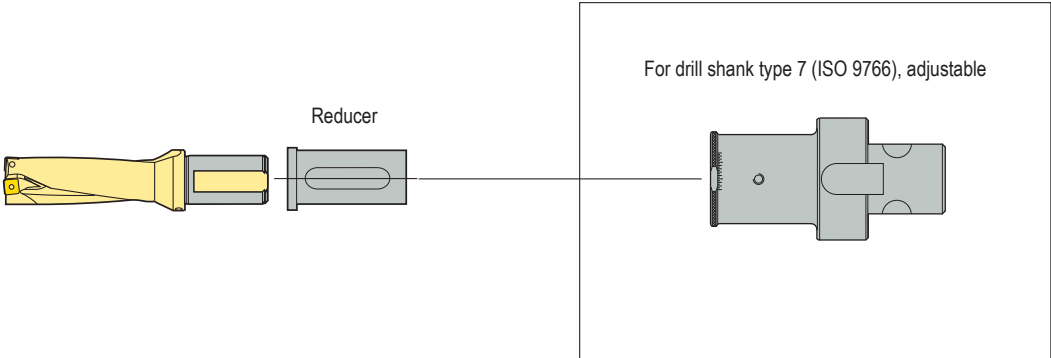

EPB 6100 – Adjustable drill holders, for type 7 drill shanks – ISO 9766 – Metric

Graflex®



- For Performax™ drills
- Adjustable from -0,3 mm to +0,8

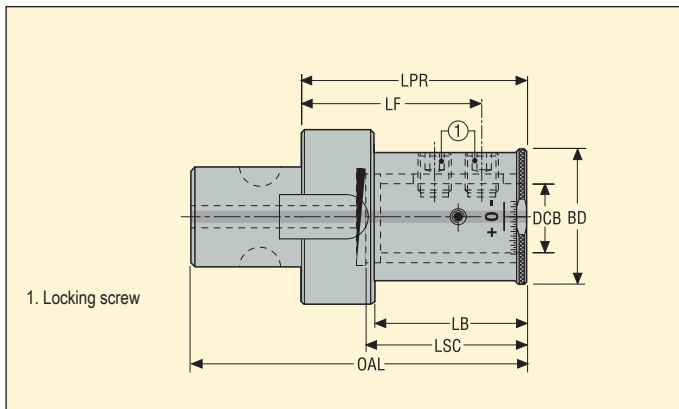

Machine side	Workpiece side		Designation	Dimensions in mm						Balancing	KG	
	Graflex shank size	For drill shank type		DCB mm	LPR	LF	BD	OAL	LB			LSC
G6		R7	25,0	BM061610025	70,0	55,0	49,0	110,0	54,0	54,0	PB	1,12
		R7	32,0	BM061610032	85,0	70,0	71,0	125,0	66,0	60,5	PB	2,09
		R7	40,0	BM061610040	85,0	70,0	81,0	125,0	66,0	60,5	PB	2,38

PB=Pre-balanced by design (see Balancing Guide page in Tooling Systems catalogue for more details)

Spare Parts

For DCB mm	Tenon	Locking screw
25	90M61	950AF1210014
32	90M61	950AF1210020
40	90M61	950AF1210020

Accessories*

Key	Reducing sleeve	Reducing sleeve 2
H06-4	-	-
H06-4	05B61003225	-
H06-4	05B61004025	05B61004032

*Accessories not included in delivery. Please check availability in current price and stock-list.

EPB 6101 – Adjustable drill holders, for type 7 drill shanks - Inch

Graflex®



- For Performax™ drills
- Adjustable from -0,3 mm to +0,8

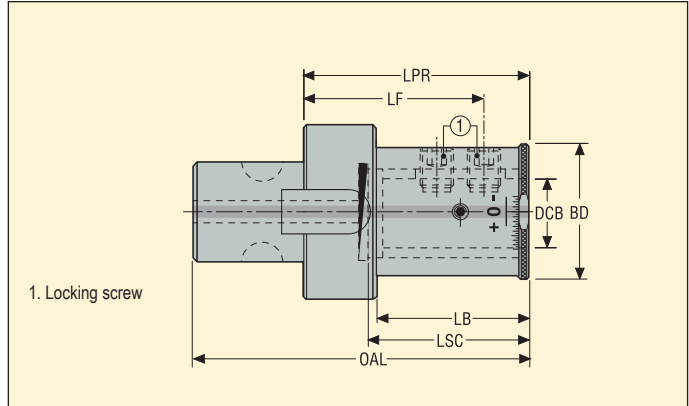

Machine side	Workpiece side		Designation	Dimensions in mm						Balancing	
	Graflex shank size	For drill shank type		DCB mm	LPR	LF	BD	OAL	LB		
G6	R7	25,4	BM061610125	70,0	55,0	49,0	110,0	54,0	54,5	PB	1,11
	R7	31,75	BM061610131	85,0	70,0	71,0	125,0	66,0	60,5	PB	2,09
	R7	38,1	BM061610138	85,0	70,0	81,0	125,0	66,0	60,5	PB	2,45

PB=Pre-balanced by design (see Balancing Guide page in Tooling Systems catalogue for more details)

Spare Parts

Accessories*

For DCB inch	Tenon	Locking screw	Key
1,00	90M61	950AF1210014	H06-4
1,25	90M61	950AF1210020	
1,50	90M61	950AF1210020	

*Accessories not included in delivery. Please check availability in current price and stock-list.







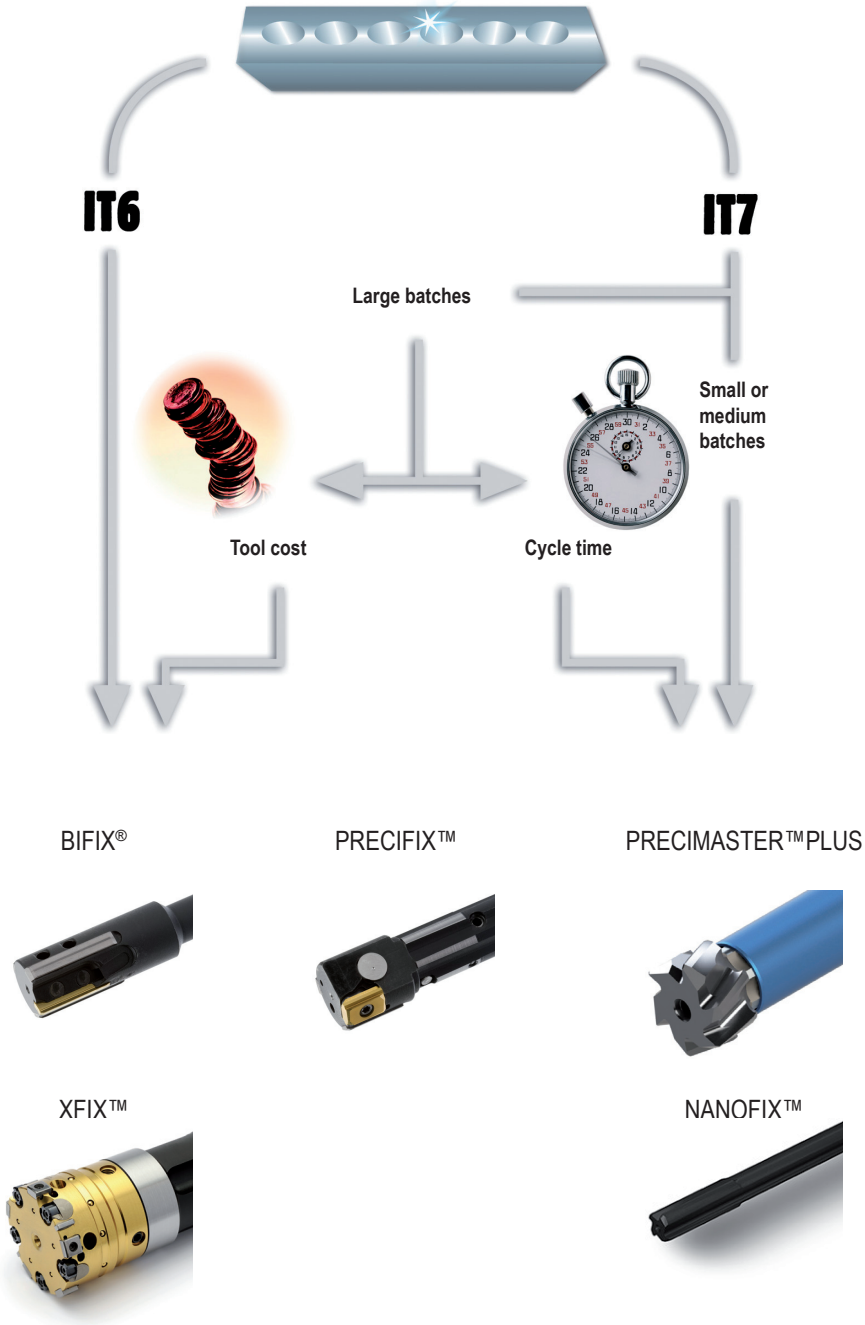

Multi-cut or indexable insert – Choosing the best solution

Quality, performance and tool cost, all these objectives can be met. The choice of a reaming tool depends on hole tolerance, production quantity and cycle time. Seco Holemaking systems can meet these demands.

With Precimaster, Precifix, Bifix, new Xfix and Nanofix reamers Seco can solve all problems related to reaming operations.



The chart below helps you to choose the ideal reaming tool



	∅ Range	Reaming depth	Hole ∅ tolerance	Intermediate diameter	Surface finish (2)
<p>Precimaster™ Plus</p>  <p>Page(s) 232-260</p>	7,75–60,500	~ 2–10 x D	IT 6–7–8	Yes, available through Custom design	R _a 0,4–0,8 μm
<p>Nanofix™</p>  <p>Page(s) 261-281</p>	2,970-12,050	~ 5-12 x D	IT 7	Yes, available through Custom design	R _a 0,8–1,2 μm
<p>Bifix®</p>  <p>Page(s) 282-302</p>	5,900–60,500	~ 2–7 x D	IT 6–7	Yes, available through Custom design	R _a 0,2–0,8 μm
<p>Precifix™</p>  <p>Page(s) 303-324</p>	11,750–60,500	~ 2–10 x D	IT 6–7	Yes, available through Custom design	R _a 0,4–0,8 μm
<p>Xfix™</p>  <p>Page(s) 325-361</p>	39,500-154,500	~ 2,5-6,5 x D	IT 6	Yes, available through Custom design	R _a 0,4–0,8 μm

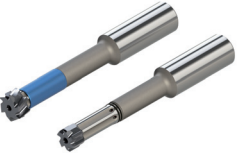

Range overview

Precimaster™ Plus	∅ Range	Reaming depth	Hole ∅ tolerance	Intermediate diameter	Surface finish (2)
 <p>PMX5/PMX6/PMX8</p>	7,75-60 mm	~ 2-3 x D	IT 6-7-8	Yes, available through Custom design	R _a 0,4-0,8 μm
 <p>PMX5/PMX6/PMX8</p>	7,75-60 mm	~ 4-5 x D	IT 6-7-8	Yes, available through Custom design	R _a 0,4-0,8 μm
 <p>PMX5/PMX6/PMX8</p>	7,75-60 mm	~ 8-10 x D	IT 6-7-8	Yes, available through Custom design	R _a 0,4-0,8 μm

Code key tool shank

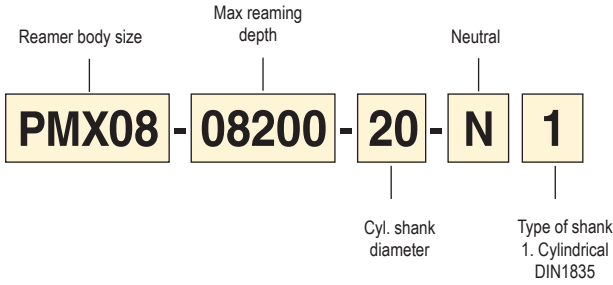

Precimaster Plus toolholders are suitable for both blind and through holes.



Code key head

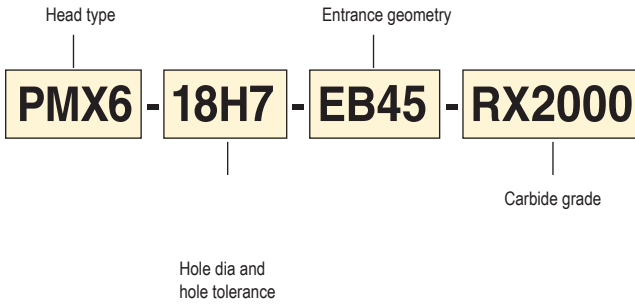

PMX6

Code key head intermediate diameter

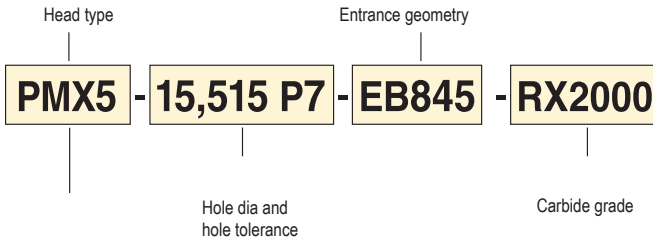

PMX5

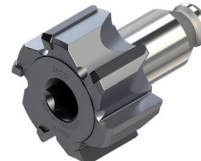

PMX8

PMX5 : Straight flutes design, suitable for blind and through bores.
 PMX6 : Helical flutes design, suitable for through bores only.
 PMX8: Straight flutes expandable, suitable for blind and through bores
 The left hand flutes design improves the action of pushing the chips forward.
 See Precimaster Plus head choice page 240.

Coolant set-up

Coolant outlet set-up procedure: Spare parts description

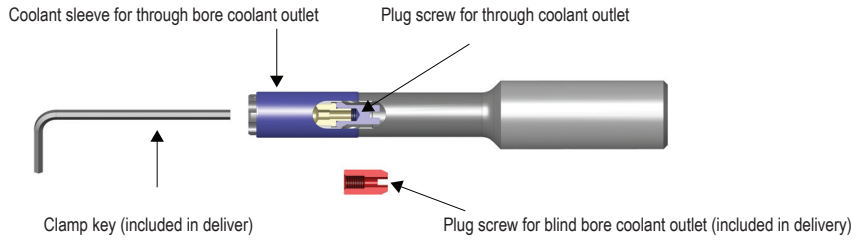

Coolant outlet set-up procedure: Blind bores coolant outlet set-up

1) Remove plug screw for through bore (blue)

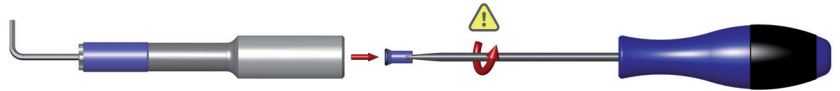

Note : Plug screws are LH pitch

Use flat screw driver OR allen key, recommended hand-tool sizes as per table

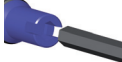
Body size	Flat blade screw driver size	Allen Key size
		
PMX05	1,2 x 4 x 120	2 x 120
PMX06	1,0 x 5,5 x 150	2,5 x 150
PMX08	1,2 x 6,5 x 200	3 x 200
PMX12	1,2 x 8 x 200	5 x 200

2) Remove coolant sleeve

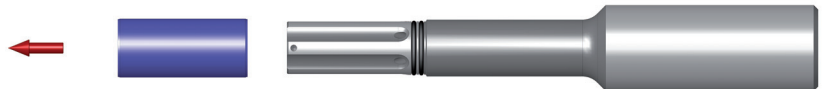







3) Mount plug screw for blind bores (red)

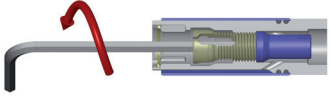

Note : Plug screws are LH pitch

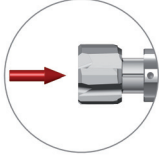
Head mounting

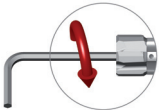
<p>1) Make sure head geometry is suitable with coolant style</p>	 <p>PMX5 PMX6 Through bores</p>
	 <p>PMX5 Blind bores</p>
<p>2) Position clamp before head mounting</p>	
<p>3) Align index groove with red dot on body</p>	
<p>4) Place head into body</p>	
<p>5) Push head inside body until "click" is achieved</p>	
<p>6) Clamp head using allen key</p>	

Set up – Run-out

Rotating tool

Max recommended run-out : 10-15 μm .

Hydraulic chuck , Shrinkfit, holder or precision collet holder is recommended.

For best run-out control, we recommend to use Precimaster Plus PMX-AD adjustable adapters, see page 247-248

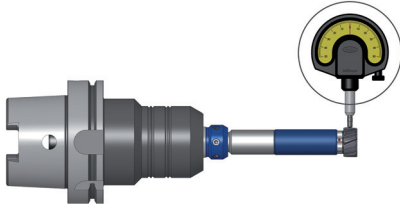

Static tool

Use Precimaster Plus floating holders PMX - FL. see page 249-250.

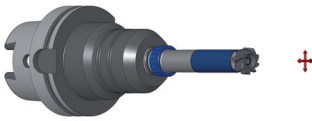

Floating holders allow reamer self-centring in pre-bore.

Coolant requirements

To reach maximum tool life and hole quality, the following coolant requirements should be observed.

Coolant through the tool is recommended.

External coolant supply can be used if reaming depth $< 2 \times D$.

Quality soluble oil with 40% minimum mineral oil.

Neat oil recommended for stainless steel.

Concentration minimum 6–8%.

Filtration 30–50 μm .

Volume min 0,5 l/min/mm in tool diameter. (Ex: Reamer \varnothing 10, min volume is 5 l/min).

Diameter measurement



Gauge clock micrometer prior to \varnothing measurement.

Important!

Precimaster reamers have differential pitch between the teeth.

When measuring the diameter, make sure that you have 2 teeth 180° opposite.

Use clock micrometer and measuring blocks for gauging.

Precimaster Plus Adjusting shanks set-up:

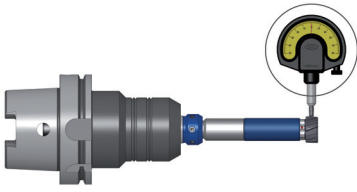

- 1) Mount tool in machine spindle
- 2) Set-up clock as shown

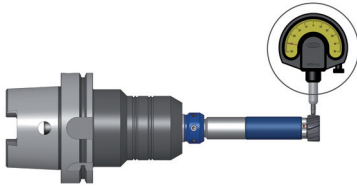

- 3) Rotate tool manually till lowest point is reached

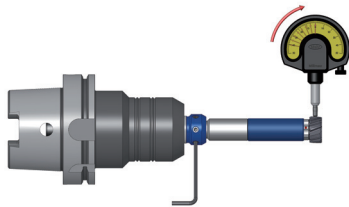

- 4) Proceed to run-out compensation using adjusting screws. Direction as shown with arrows
- 5) Check run-out and repeat compensation if necessary

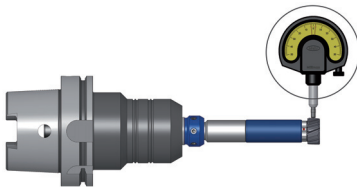

- 6) When maximum run-out is less than 5 μm , secure adjusting screws clamping to avoid losing adjustment

Precimaster Plus Floating shanks set-up:

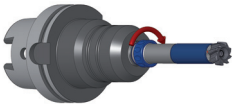

1) Completely lock floating shank turning adjusting ring clockwise

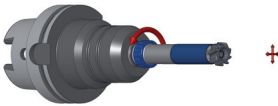

2) Open floating shank 2 or 3 clicks turning adjusting ring anti-clockwise

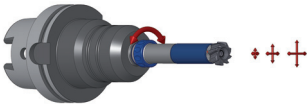

3) Proceed to further floating value adjustment if necessary
Too much floating value can create unstable conditions at bore entry.
Too few floating value can create vibrations and tapered bore.

Precimaster Plus Expandable reamer wear compensation:

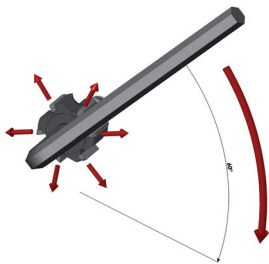



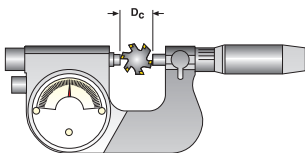



1) Use hexagonal allen key to compensate tool \emptyset wearing
(60° revolution = approximately 5 μm compensation on \emptyset)

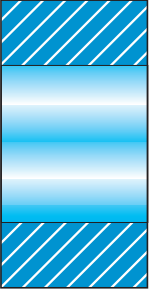

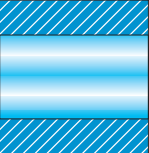
2) Check \emptyset dimension after expansion using clock micrometer

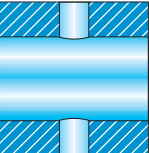
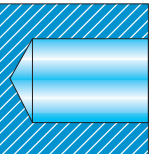
Head choice – Choose cutting head style according to application and diameter

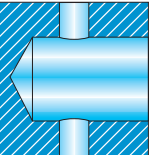
Workpiece	Diameter to ream \varnothing 10-60	
<p>Short through hole < 3 x D</p> 	<p>PMX5/PMX8</p> 	
<p>Long through hole > 3 x D</p> 	<p>PMX6</p> 	
<p>Crossing hole</p> 	<p>For through bore application, toolholder coolant outlet must be set for through holes: see coolant set up pages</p>	
<p>Blind hole</p> 	<p>PMX5/PMX8</p> 	
<p>Blind and crossing hole</p> 	<p>For blind bore application, toolholder coolant outlet must be set for blind holes: see coolant set up pages</p>	



Geometry choice – Applications

Lead geometry - EB45

Chip control +++
 Surface Finish + (R_a 0,8 - 1,2 μm)
 Versatile

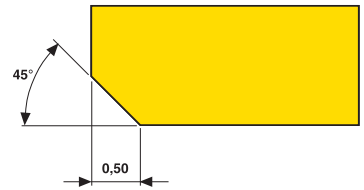

Lead geometry - EB845

Chip control ++
 Surface finish+++ (R_a 0,2 - 0,8 μm)

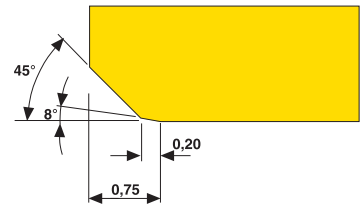

Lead geometry - EB25

Feed performance +++
 Surface finish ++ (R_a 0,4 - 0,8 μm)
 Chip control +

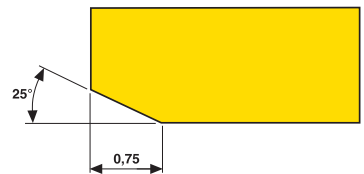

Grades

	CP20	Coated A versatile coated grade suitable for most materials, except aluminum. TiN
	H15	Uncoated A tough micrograin grade for all materials. Suitable for fine-reaming operations due to edge sharpness.
	CF	Cermet A wear resistant grade for performance optimization in steel.
	RX1500	Coated Cermet A wear resistant coated grade for performance optimization in steel and cast iron.
	RX2000	Coated High performance coated grade suitable for all materials.

Grades

	RN2010	A sub-micrograin uncoated grade with optimized geometries for N-materials (non ferrous).
	RM2020	A tough coated grade suitable for fine reaming operation with optimized geometries for M materials.
	RM2090	A wear resistant coated grade with specific geometries for M materials. Optimisation in M materials.
	RS2090	A wear resistant coated grade with specific geometries for S materials. Optimisation in S materials.

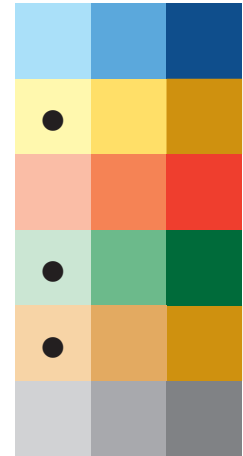

Heads for through and blind holes \varnothing 8-32 mm



- For cutting data see page(s) 251-252
- For choice of lead geometry EB45, EB845 or EB25 see page(s) 241

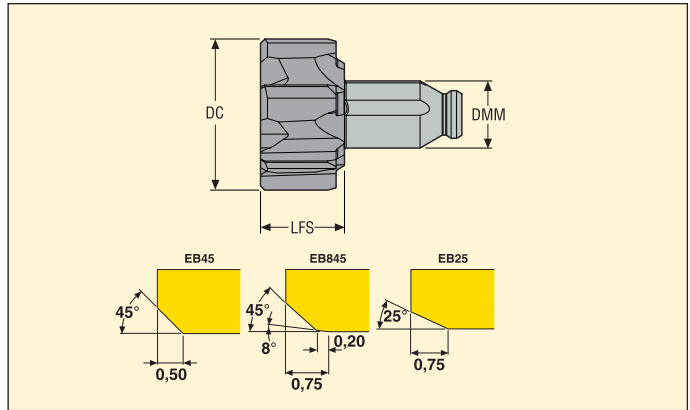

DC	Drill size*	Designation		LFS	DMM	Body size	Geometries			Grades				
							EB45	EB845	EB25	H15	CP20	RX2000	CF	RX1500
8,0	7,8/7,9	PMX5-8H7-EB45	6	6,0	4,5	PMX05-xx	■	□	□	□	□	03123158	□	□
9,0	8,8/8,9	PMX5-9H7-EB45	6	6,0	4,5	PMX05-xx	■	□	□	□	□	03123159	□	□
10,0	9,8/9,9	PMX5-10H7-EB45	6	7,0	6,0	PMX06-xx	■	□	□	□	□	02965840	02965923	□
11,0	10,8/10,9	PMX5-11H7-EB45	6	7,0	6,0	PMX06-xx	■	□	□	□	□	02925754	□	□
12,0	11,8/11,908	PMX5-12H7-EB45	6	7,0	6,0	PMX06-xx	■	□	□	□	□	02925755	02925041	□
13,0	12,8/12,9	PMX5-13H7-EB45	6	7,0	6,0	PMX06-xx	■	□	□	□	□	02925756	02925042	□
14,0	13,8/13,891	PMX5-14H7-EB45	6	7,0	6,0	PMX06-xx	■	□	□	□	□	02925757	02925043	□
15,0	14,8/14,9	PMX5-15H7-EB45	6	10,0	8,0	PMX08-xx	■	□	□	□	□	02925758	02925044	□
16,0	15,8/15,9	PMX5-16H7-EB45	6	10,0	8,0	PMX08-xx	■	□	□	□	□	02925759	02925045	□
17,0	16,8/16,9	PMX5-17H7-EB45	6	10,0	8,0	PMX08-xx	■	□	□	□	□	02925760	02925046	□
18,0	17,8/17,9	PMX5-18H7-EB45	6	10,0	8,0	PMX08-xx	■	□	□	□	□	02925761	02925047	□
19,0	18,8/18,9	PMX5-19H7-EB45	6	10,0	8,0	PMX08-xx	■	□	□	□	□	02925762	□	□
20,0	19,8/19,9	PMX5-20H7-EB45	6	10,0	8,0	PMX08-xx	■	□	□	□	□	02925763	02925048	□
21,0	20,8/20,9	PMX5-21H7-EB45	6	10,0	8,0	PMX08-xx	■	□	□	□	□	02925764	□	□
22,0	21,8/21,9	PMX5-22H7-EB45	8	12,0	12,0	PMX12-xx	■	□	□	□	□	02925765	02925049	□
23,0	22,8/22,9	PMX5-23H7-EB45	8	12,0	12,0	PMX12-xx	■	□	□	□	□	02925766	□	□
24,0	23,813/23,9	PMX5-24H7-EB45	8	12,0	12,0	PMX12-xx	■	□	□	□	□	02925767	02925050	□
25,0	24,8/24,9	PMX5-25H7-EB45	8	12,0	12,0	PMX12-xx	■	□	□	□	□	02925768	02925051	□
26,0	25,8/25,9	PMX5-26H7-EB45	8	12,0	12,0	PMX12-xx	■	□	□	□	□	02925769	02925052	□
27,0	26,8/26,9	PMX5-27H7-EB45	8	12,0	12,0	PMX12-xx	■	□	□	□	□	02925770	□	□
28,0	27,8/27,9	PMX5-28H7-EB45	8	12,0	12,0	PMX12-xx	■	□	□	□	□	02925771	02925053	□
29,0	28,8/28,9	PMX5-29H7-EB45	8	12,0	12,0	PMX12-xx	■	□	□	□	□	02925772	□	□
30,0	29,8/29,9	PMX5-30H7-EB45	8	12,0	12,0	PMX12-xx	■	□	□	□	□	02925773	02925054	□
31,0	30,8/30,9	PMX5-31H7-EB45	8	12,0	12,0	PMX12-xx	■	□	□	□	□	02925774	□	□
32,0	31,8/31,9	PMX5-32H7-EB45	8	12,0	12,0	PMX12-xx	■	□	□	□	□	02925775	02925055	□

*For further information on which drill to use and how to use it see page(s) 9

■ Stock standard □ Non stock standard. Subject to change refer to current price- and stock-list.

Heads for through holes \varnothing 8-32 mm



- For cutting data see page(s) 251-252
- For choice of lead geometry EB45, EB845 or EB25 see page(s) 241

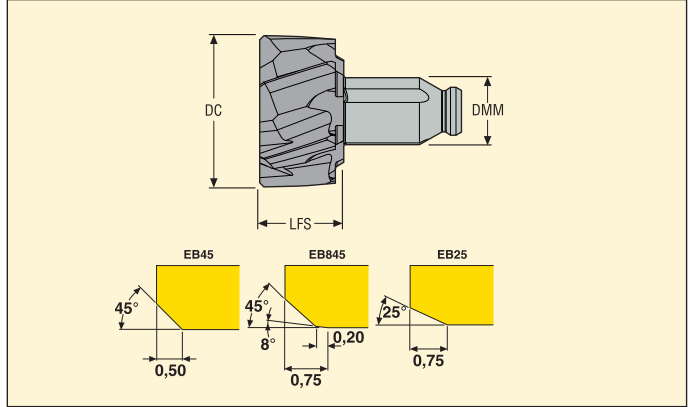

DC	Drill size*	Designation		LFS	DMM	Body size	Geometries			Grades					
							EB45	EB845	EB25	H15	CP20	RX2000	CF	RX1500	
8,0	7,8/7,9	PMX6-8H7-EB45	6	6,0	4,5	PMX05-xx	■						03123161		
9,0	8,8/8,9	PMX6-9H7-EB45	6	6,0	4,5	PMX05-xx	■						03123162		
10,0	9,8/9,9	PMX6-10H7-EB45	6	7,0	6,0	PMX06-xx	■						02965863		
11,0	10,8/10,9	PMX6-11H7-EB45	6	7,0	6,0	PMX06-xx	■						02925776		
12,0	11,8/11,908	PMX6-12H7-EB45	6	7,0	6,0	PMX06-xx	■						02925777		
13,0	12,8/12,9	PMX6-13H7-EB45	6	7,0	6,0	PMX06-xx	■						02925778		
14,0	13,8/13,891	PMX6-14H7-EB45	6	7,0	6,0	PMX06-xx	■						02925779		
15,0	14,8/14,9	PMX6-15H7-EB45	6	10,0	8,0	PMX08-xx	■						02925780		
16,0	15,8/15,9	PMX6-16H7-EB45	6	10,0	8,0	PMX08-xx	■						02925781		
17,0	16,8/16,9	PMX6-17H7-EB45	6	10,0	8,0	PMX08-xx	■						02925782		
18,0	17,8/17,9	PMX6-18H7-EB45	6	10,0	8,0	PMX08-xx	■						02925783		
19,0	18,8/18,9	PMX6-19H7-EB45	6	10,0	8,0	PMX08-xx	■						02925784		
20,0	19,8/19,9	PMX6-20H7-EB45	6	10,0	8,0	PMX08-xx	■						02925785		
21,0	20,8/20,9	PMX6-21H7-EB45	6	10,0	8,0	PMX08-xx	■						02925786		
22,0	21,8/21,9	PMX6-22H7-EB45	8	12,0	12,0	PMX12-xx	■						02925030		
23,0	22,8/22,9	PMX6-23H7-EB45	8	12,0	12,0	PMX12-xx	■						02925031		
24,0	23,813/23,9	PMX6-24H7-EB45	8	12,0	12,0	PMX12-xx	■						02925032		
25,0	24,8/24,9	PMX6-25H7-EB45	8	12,0	12,0	PMX12-xx	■						02925033		
26,0	25,8/25,9	PMX6-26H7-EB45	8	12,0	12,0	PMX12-xx	■						02925034		
27,0	26,8/26,9	PMX6-27H7-EB45	8	12,0	12,0	PMX12-xx	■						02925035		
28,0	27,8/27,9	PMX6-28H7-EB45	8	12,0	12,0	PMX12-xx	■						02925036		
29,0	28,8/28,9	PMX6-29H7-EB45	8	12,0	12,0	PMX12-xx	■						02925037		
30,0	29,8/29,9	PMX6-30H7-EB45	8	12,0	12,0	PMX12-xx	■						02925038		
31,0	30,8/30,9	PMX6-31H7-EB45	8	12,0	12,0	PMX12-xx	■						02925039		
32,0	31,8/31,9	PMX6-32H7-EB45	8	12,0	12,0	PMX12-xx	■						02925040		

*For further information on which drill to use and how to use it see page(s) 9

■ Stock standard □ Non stock standard. Subject to change refer to current price- and stock-list.

Shanks for through and blind holes \varnothing 7,75-60,500 mm



- For cutting data see page(s) 251-252
- For choice of lead geometry EB45, EB45 or EB25 see page(s) 241

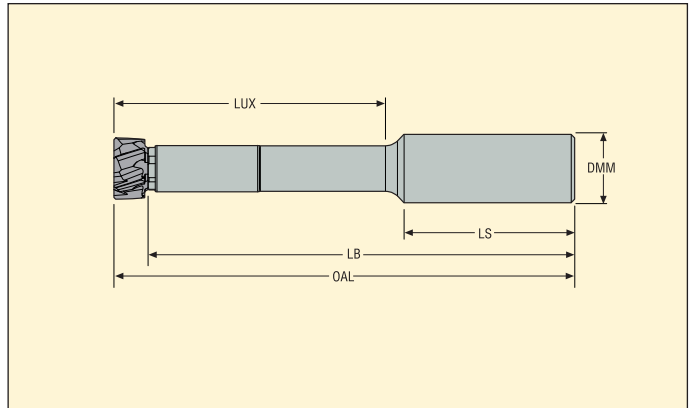

DC	Tool holder material	Ordering and Product No.	Designation	Dimensions in mm				
				OAL	LB	LS	LUX	DMM
7,75-9,999	Steel	03123012	PMX05-02800-10N1	69	63	40	28	10
	Steel	02929923	PMX05-04100-10N1	84	78	40	41	10
	Steel	03123013	PMX05-10000-10N1	143	137	40	100	10
10,0-14,499	Steel	02925828	PMX06-03700-12N1	84	77	45	37	12
	Steel	02925829	PMX06-05700-12N1	104	97	45	57	12
	Steel	02925830	PMX06-12000-12N1	167	160	45	120	12
	Carbide	02925831	PMX06HM-12000-12N1	167	160	45	120	12
14,5-21,499	Steel	02925832	PMX08-04600-20N1	99	89	50	46	20
	Steel	02925833	PMX08-08200-20N1	135	125	50	82	20
	Steel	02925834	PMX08-14500-20N1	198	188	50	145	20
	Carbide	02925835	PMX08HM-14500-20N1	198	188	50	145	20
21,5-32,499	Steel	02925836	PMX12-06800-25N1	127	115	56	68	25
	Steel	02925837	PMX12-10400-25N1	163	151	56	104	25
	Steel	02925838	PMX12-17000-25N1	229	217	56	170	25
	Carbide	02925839	PMX12HM-17000-25N1	229	217	56	170	25
32,5-60,5	Steel	02925840	PMX16-06300-32N1	124	110	61	63	32
	Steel	02925841	PMX16-12700-32N1	188	174	61	127	32
	Steel	02925842	PMX16-17000-32N1	231	217	61	170	32
	Carbide	02925843	PMX16HM-17000-32N1	231	217	61	170	32

Spare Parts

For shank	For \varnothing (mm)	Clamp key	Clamp kit	Coolant kit	Plug screw, blind bore	Plug screw, through bore
PMX05	7,75-9,900	1.5SMS795	PMX05-CLKI	RT05-KI	SB05	ST05
PMX06	9,901-14,499	2SMS795	PMX06-CLKI	RT06-KI	SB06	ST06
PMX08	14,5-21,499	2.5SMS795	PMX08-CLKI	RT08-KI	SB08	ST08
PMX12	21,5-32,499	4SMS795	PMX12-CLKI	RT12-KI	SB12	ST12
PMX16	32,5-60	5SMS795	PMX16-CLKI	-	SB16	ST16

*Spare parts for PMX16 bodies only. For PMX16, plug screws are also used for clamping. Accessories, see page(s) 247

Shanks for blind holes \varnothing 7,75-60,500

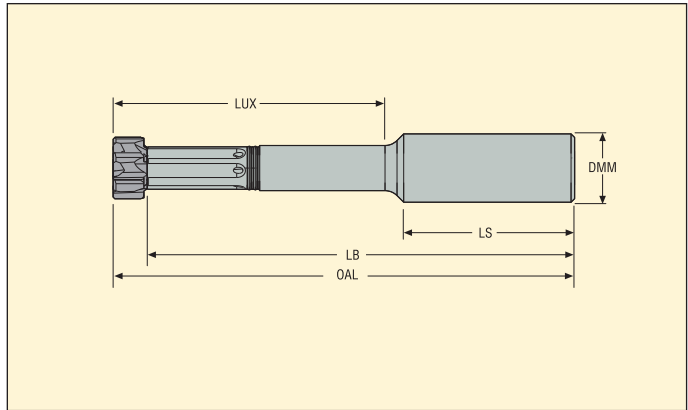

DC	Tool holder material	Ordering and Product No.	Designation	Dimensions in mm				
				OAL	LB	LS	LUX	DMM
7,75-9,999	Steel	03144322	PMX05B-02800-10N1	69	63	40	28	10
	Steel	03144323	PMX05B-04100-10N1	84	78	40	41	10
	Steel	03144324	PMX05B-10000-10N1	143	137	40	100	10
10,0-14,499	Steel	03075433	PMX06B-03700-12N1	84	77	45	37	12
	Steel	03075434	PMX06B-05700-12N1	104	97	45	57	12
	Steel	03075435	PMX06B-12000-12N1	167	160	45	120	12
	Carbide	03075436	PMX06BHM-12000-12N1	167	160	45	120	12
14,5-21,499	Steel	03075437	PMX08B-04600-20N1	99	89	50	46	20
	Steel	03075438	PMX08B-08200-20N1	135	125	50	82	20
	Steel	03075439	PMX08B-14500-20N1	198	188	50	145	20
	Carbide	03075440	PMX08BHM-14500-20N1	198	188	50	145	20
21,5-32,499	Steel	03075441	PMX12B-06800-25N1	127	115	56	68	25
	Steel	03075442	PMX12B-10400-25N1	163	151	56	104	25
	Steel	03075443	PMX12B-17000-25N1	229	217	56	170	25
	Carbide	03075444	PMX12BHM-17000-25N1	229	217	56	170	25
32,5-60,5	Steel	03075445	PMX16B-06300-32N1	124	110	61	63	32
	Steel	03075446	PMX16B-12700-32N1	188	174	61	127	32
	Steel	03075447	PMX16B-17000-32N1	231	217	61	170	32
	Carbide	03075448	PMX16BHM-17000-32N1	231	217	61	170	32

Spare Parts

For shank	For \varnothing (mm)	Clamp key	Clamp kit	Plug screw, blind bore
PMX05B	7,75-9,900	1.5SMS795	PMX05-CLKI	SB05
PMX06B	9,901-14,499	2SMS795	PMX06-CLKI	SB06
PMX08B	14,500-21,499	2.5SMS795	PMX08-CLKI	SB08
PMX12B	21,500-32,499	4SMS795	PMX12-CLKI	SB12
PMX16B	32,500-60,000	5SMS795	PMX16-CLKI	SB16

*Spare parts for PMX16 bodies only. For PMX16, plug screws are also used for clamping.

Accessories, see page(s) 247

Adjustable shanks for through holes \varnothing 10-60,500 mm

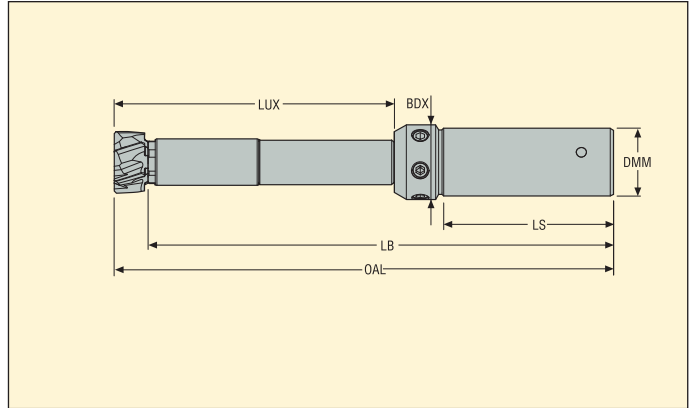

- For cutting data see page(s) 251-252
- For choice of lead geometry EB45, EB845 or EB25 see page(s) 241

DC	Ordering and Product No.	Designation	Dimensions in mm					
			OAL	LB	LS	LUX	BDX	DMM
9,901-14,499	03002833	PMX06T-AD-05700-16N1	117	110	48	57	18	16
14,5-21,499	03002835	PMX08T-AD-08200-20N1	147	137	50	82	22	20
21,5-32,499	03002837	PMX12T-AD-10400-25N1	179	167	56	104	28	25
32,5-60,5	03002839	PMX16T-AD-12700-32N1	214	200	60	127	34	32

Spare Parts

For shank	For \varnothing (mm)	Clamp key	Coolant ring	Setting key	Setting Master
PMX06T	9,901-14,499	2SMS795	RT06-KI	2SMS795	PMX06-MSTR
PMX08T	14,50-21,499	2.5SMS795	RT08-KI	2.5SMS795	PMX08-MSTR
PMX12T	21,50-32,499	4SMS795	RT12-KI	3SMS795	PMX12-MSTR
PMX16T	32,50-60,000	5SMS795	-	3SMS795	-

Accessories

\varnothing Range	Shank Size	Ordering and Product No.	Torque key	Ordering and Product No.	Replacement blade	Torque value
7,750-9,900	PMX05	03178237	H00-1.5-27	03178196	H00-1505-24	0,5 Nm
9,901-14,499	PMX06	03178238	H00-2.0-33	03178197	H00-2009-33	0,9 Nm
14,500-21,499	PMX08	03178240	H00-2.5-40	03178199	H00-2512-40	1,2 Nm
21,500-32,499	PMX12	03178242	H00-4.0-60	03178201	H00-4020-60	2,0 Nm

Adjustable shanks for blind holes \varnothing 10-60,500 mm

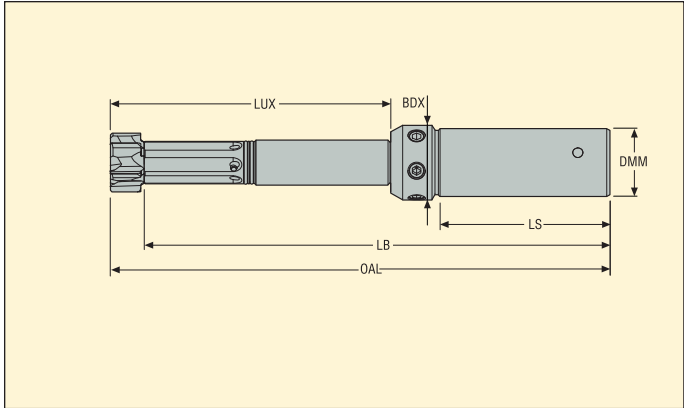

- For cutting data see page(s) 251-252
- For choice of lead geometry EB45, EB845 or EB25 see page(s) 241

DC	Ordering and Product No.	Designation	Dimensions in mm					
			OAL	LB	LS	LUX	BDX	DMM
9,901-14,499	03002834	PMX06B-AD-05700-16N1	117	110	48	57	18	16
14,5-21,499	03002836	PMX08B-AD-08200-20N1	147	137	50	82	22	20
21,5-32,499	03002838	PMX12B-AD-10400-25N1	179	167	56	104	28	25
32,5-60,5	03002840	PMX16B-AD-12700-32N1	214	200	60	127	34	32

Spare Parts

For shank	For \varnothing (mm)	Clamp key	Setting key	Setting Master
PMX06B	9,901-14,499	2SMS795	2SMS795	PMX06-MSTR
PMX08B	14,50-21,499	2.5SMS795	2.5SMS795	PMX08-MSTR
PMX12B	21,50-32,499	4SMS795	3SMS795	PMX12-MSTR
PMX16B	32,50-60,000	5SMS795	3SMS795	-

Accessories

\varnothing Range	Shank Size	Ordering and Product No.	Torque key	Ordering and Product No.	Replacement blade	Torque value
7,750-9,900	PMX05	03178237	H00-1.5-27	03178196	H00-1505-24	0,5 Nm
9,901-14,499	PMX06	03178238	H00-2.0-33	03178197	H00-2009-33	0,9 Nm
14,500-21,499	PMX08	03178240	H00-2.5-40	03178199	H00-2512-40	1,2 Nm
21,500-32,499	PMX12	03178242	H00-4.0-60	03178201	H00-4020-60	2,0 Nm

Floating shanks for through holes \varnothing 10-60,500 mm



- For cutting data see page(s) 251-252
- For choice of lead geometry EB45, EB845 or EB25 see page(s) 241

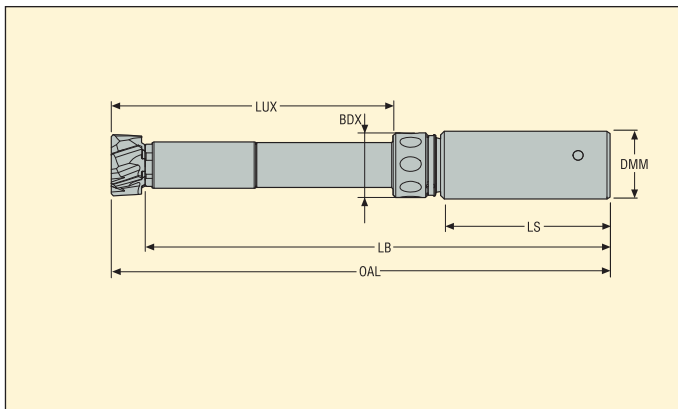

DC	Ordering and Product No.	Designation	Dimensions in mm					
			OAL	LB	LS	LUX	BDX	DMM
9,901-14,499	03002825	PMX06T-FL-05700-16N1	117	110	48	57	15	16
14,5-21,499	03002827	PMX08T-FL-08200-20N1	147	137	50	82	19	20
21,5-32,499	03002829	PMX12T-FL-10400-25N1	179	167	56	104	28	25
32,5-60,5	03002831	PMX16T-FL-12700-32N1	214	200	60	127	34	32

Spare Parts

For shank	For \varnothing (mm)	Clamp key	Coolant ring
PMX06T	9,901-14,499	2SMS795	RT06-KI
PMX08T	14,50-21,499	2.5SMS795	RT08-KI
PMX12T	21,50-32,499	4SMS795	RT12-KI
PMX16T	32,50-60,000	5SMS795	-

Accessories

\varnothing Range	Shank Size	Ordering and Product No.	Torque key	Ordering and Product No.	Replacement blade	Torque value
7,750-9,900	PMX05	03178237	H00-1.5-27	03178196	H00-1505-24	0,5 Nm
9,901-14,499	PMX06	03178238	H00-2.0-33	03178197	H00-2009-33	0,9 Nm
14,500-21,499	PMX08	03178240	H00-2.5-40	03178199	H00-2512-40	1,2 Nm
21,500-32,499	PMX12	03178242	H00-4.0-60	03178201	H00-4020-60	2,0 Nm

Floating shanks for blind holes \varnothing 10-60,500 mm

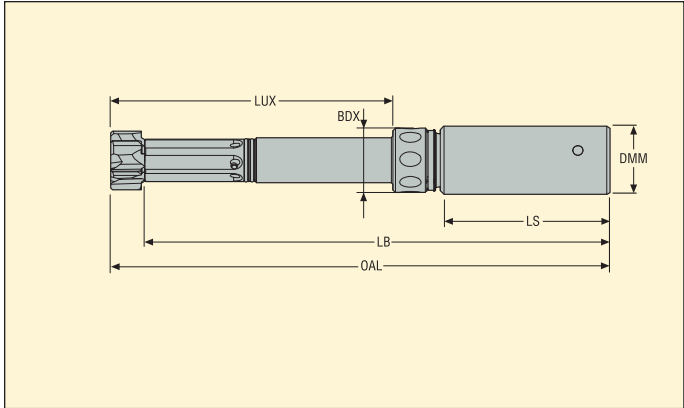

- For cutting data see page(s) 251-252
- For choice of lead geometry EB45, EB845 or EB25 see page(s) 241

DC	Ordering and Product No.	Designation	Dimensions in mm					
			OAL	LB	LS	LUX	BDX	DMM
9,901-14,499	03002826	PMX06B-FL-05700-16N1	117	110	48	57	15	16
14,5-21,499	03002828	PMX08B-FL-08200-20N1	147	137	50	82	19	20
21,5-32,499	03002830	PMX12B-FL-10400-25N1	179	167	56	104	28	25
32,5-60,5	03002832	PMX16B-FL-12700-32N1	214	200	60	127	34	32

Spare Parts

For shank	For \varnothing (mm)	Clamp key
PMX06B	9,901-14,499	2SMS795
PMX08B	14,50-21,499	2.5SMS795
PMX12B	21,50-32,499	4SMS795
PMX16B	32,50-60,500	5SMS795

Accessories

\varnothing Range	Shank Size	Ordering and Product No.	Torque key	Ordering and Product No.	Replacement blade	Torque value
7,750-9,900	PMX05	03178237	H00-1.5-27	03178196	H00-1505-24	0,5 Nm
9,901-14,499	PMX06	03178238	H00-2.0-33	03178197	H00-2009-33	0,9 Nm
14,500-21,499	PMX08	03178240	H00-2.5-40	03178199	H00-2512-40	1,2 Nm
21,500-32,499	PMX12	03178242	H00-4.0-60	03178201	H00-4020-60	2,0 Nm

Cutting data – PM Plus...-EB845

SMG		a _p (°)		f			v _c				
		z=6	z=8	z=6	z=8	z=10	H15	CP20	RX2000	CF	RX1500
P3	PMX5/PMX6/PMX8-EB845	0,10-0,20	0,10-0,30	0,20-0,90	0,30-1,20	0,30-1,50	-	60 (30-100)	80 (30-150)	180 (90-200)	220 (120-300)
P4	PMX5/PMX6/PMX8-EB845	0,10-0,20	0,10-0,30	0,20-0,70	0,30-0,90	0,40-1,10	-	50 (30-80)	60 (30-120)	120 (80-150)	180 (90-200)
P5	PMX5/PMX6/PMX8-EB845	0,10-0,20	0,10-0,30	0,20-0,70	0,30-0,90	0,40-1,10	20 (10-25)	50 (30-80)	60 (30-120)	120 (80-150)	180 (90-200)
P6	PMX5/PMX6/PMX8-EB845	0,10-0,20	0,10-0,30	0,20-0,70	0,30-0,90	0,40-1,10	20 (10-25)	50 (30-80)	60 (30-120)	120 (80-150)	180 (90-200)
P7	PMX5/PMX6/PMX8-EB845	0,10-0,20	0,10-0,30	0,20-0,70	0,30-0,90	0,40-1,10	20 (10-25)	50 (30-80)	60 (30-120)	120 (80-150)	180 (90-200)
P8	PMX5/PMX6/PMX8-EB845	0,10-0,20	0,10-0,30	0,20-0,70	0,30-0,90	0,40-1,10	15 (10-20)	35 (20-60)	40 (20-80)	80 (60-120)	120 (80-180)
P11	PMX5/PMX6/PMX8-EB845	0,10-0,20	0,10-0,30	0,20-0,70	0,30-0,90	0,40-1,10	15 (10-20)	35 (20-60)	40 (20-80)	80 (60-120)	120 (80-180)
P12	PMX5/PMX6/PMX8-EB845	0,10-0,20	0,10-0,30	0,20-0,70	0,30-0,90	0,40-1,10	12 (8-15)	25 (15-45)	30 (15-65)	65 (45-95)	95 (65-145)
M1	PMX5/PMX6/PMX8-EB845	0,08-0,15	0,10-0,20	0,20-0,60	0,30-0,80	0,40-1,10	12 (9-15)	25 (15-40)	35 (20-70)	-	-
M2	PMX5/PMX6/PMX8-EB845	0,08-0,15	0,10-0,20	0,20-0,60	0,30-0,80	0,40-1,10	-	25 (15-40)	35 (20-70)	-	-
M3	PMX5/PMX6/PMX8-EB845	0,08-0,15	0,10-0,20	0,20-0,60	0,30-0,80	0,40-1,10	-	25 (15-40)	35 (20-70)	-	-
M4	PMX5/PMX6/PMX8-EB845	0,08-0,15	0,10-0,20	0,20-0,60	0,30-0,80	0,40-1,10	-	20 (10-30)	25 (15-50)	-	-
M5	PMX5/PMX6/PMX8-EB845	0,08-0,15	0,10-0,20	0,20-0,60	0,30-0,80	0,40-1,10	-	20 (10-30)	25 (15-50)	-	-
K1	PMX5/PMX6/PMX8-EB845	0,10-0,20	0,10-0,25	0,30-0,90	0,30-1,20	0,40-1,50	25 (15-30)	60 (40-100)	80 (30-150)	-	220 (120-300)
K2	PMX5/PMX6/PMX8-EB845	0,10-0,20	0,10-0,25	0,30-0,90	0,30-1,20	0,40-1,50	25 (15-30)	60 (40-100)	80 (30-150)	-	80 (50-100)
K3	PMX5/PMX6/PMX8-EB845	0,10-0,20	0,10-0,25	0,30-0,90	0,30-1,20	0,40-1,50	25 (15-30)	60 (40-100)	80 (30-150)	-	220 (120-300)
K4	PMX5/PMX6/PMX8-EB845	0,10-0,20	0,10-0,25	0,30-0,90	0,30-1,20	0,40-1,50	25 (15-30)	45 (30-70)	70 (40-120)	100 (70-150)	150 (80-200)
K5	PMX5/PMX6/PMX8-EB845	0,10-0,20	0,10-0,25	0,30-0,90	0,30-1,20	0,40-1,50	25 (15-30)	45 (30-70)	70 (40-120)	100 (70-150)	150 (80-200)
K6	PMX5/PMX6/PMX8-EB845	0,10-0,20	0,10-0,25	0,30-0,90	0,30-1,20	0,40-1,50	-	60 (40-100)	80 (30-150)	-	220 (120-300)
K7	PMX5/PMX6/PMX8-EB845	0,10-0,20	0,10-0,25	0,30-0,90	0,30-1,20	0,40-1,50	-	60 (40-100)	80 (30-150)	-	220 (120-300)
S1	PMX5/PMX6/PMX8-EB845	0,08-0,15	0,10-0,15	0,20-0,60	0,30-0,80	0,40-1,00	-	20 (10-25)	20 (10-25)	-	-
S2	PMX5/PMX6/PMX8-EB845	0,08-0,15	0,10-0,15	0,20-0,60	0,30-0,80	0,40-1,00	-	20 (10-25)	20 (10-25)	-	-
S3	PMX5/PMX6/PMX8-EB845	0,08-0,15	0,10-0,15	0,20-0,60	0,30-0,80	0,40-1,00	-	20 (10-25)	20 (10-25)	-	-
S11	PMX5/PMX6/PMX8-EB845	0,08-0,15	0,10-0,15	0,20-0,60	0,30-0,80	0,40-1,00	20 (15-30)	30 (15-40)	40 (20-50)	-	-
S12	PMX5/PMX6/PMX8-EB845	0,08-0,15	0,10-0,15	0,20-0,60	0,30-0,80	0,40-1,00	20 (15-30)	30 (15-40)	40 (20-50)	-	-
S13	PMX5/PMX6/PMX8-EB845	0,08-0,15	0,10-0,15	0,20-0,60	0,30-0,80	0,40-1,00	20 (15-30)	30 (15-40)	40 (20-50)	-	-
H3	PMX5/PMX6/PMX8-EB845	0,08-0,15	0,10-0,15	0,20-0,40	0,30-0,55	0,40-0,70	-	-	10 (8-15)	-	-
H5	PMX5/PMX6/PMX8-EB845	0,08-0,15	0,10-0,15	0,20-0,40	0,30-0,55	0,40-0,70	-	-	10 (8-15)	-	-
H7	PMX5/PMX6/PMX8-EB845	0,08-0,15	0,10-0,15	0,20-0,40	0,30-0,55	0,40-0,70	-	-	10 (8-15)	-	-
H8	PMX5/PMX6/PMX8-EB845	0,08-0,15	0,10-0,15	0,20-0,40	0,30-0,55	0,40-0,70	-	-	10 (8-15)	-	-
H11	PMX5/PMX6/PMX8-EB845	0,08-0,15	0,10-0,15	0,20-0,40	0,30-0,55	0,40-0,70	-	-	10 (8-15)	-	-
H12	PMX5/PMX6/PMX8-EB845	0,08-0,15	0,10-0,15	0,20-0,40	0,30-0,55	0,40-0,70	-	-	10 (8-15)	-	-
H21	PMX5/PMX6/PMX8-EB845	0,08-0,15	0,10-0,15	0,20-0,40	0,30-0,55	0,40-0,70	-	-	10 (8-15)	-	-
H31	PMX5/PMX6/PMX8-EB845	0,08-0,15	0,10-0,15	0,20-0,40	0,30-0,55	0,40-0,70	-	-	10 (8-15)	-	-
PM1	PMX5/PMX6/PMX8-EB845	0,10-0,20	0,1-0,30	0,20-0,60	0,30-0,80	0,40-1,00	-	50 (30-80)	70 (40-100)	-	-
PM2	PMX5/PMX6/PMX8-EB845	0,10-0,20	0,1-0,30	0,20-0,60	0,30-0,80	0,40-1,00	-	50 (30-80)	70 (40-100)	-	-
PM3	PMX5/PMX6/PMX8-EB845	0,10-0,20	0,1-0,30	0,20-0,60	0,30-0,80	0,40-1,00	-	50 (30-80)	70 (40-100)	-	-

Cutting data – PM Plus...-EB25

SMG		a _p (°)		f			v _c				
		z=6	z=8	z=6	z=8	z=10	H15	CP20	RX2000	CF	RX1500
P1	PMX5/PMX6/PMX8-EB25	0,10-0,20	0,10-0,30	0,80-1,80	1,00-2,40	1,20-3,00	25 (15-30)	60 (30-100)	80 (30-150)	180 (90-200)	220 (120-300)
P2	PMX5/PMX6/PMX8-EB25	0,10-0,20	0,10-0,30	0,80-1,80	1,00-2,40	1,20-3,00	25 (15-30)	60 (30-100)	80 (30-150)	180 (90-200)	220 (120-300)
P3	PMX5/PMX6/PMX8-EB25	0,10-0,20	0,10-0,30	0,80-1,80	1,00-2,40	1,20-3,00	25 (15-30)	60 (30-100)	80 (30-150)	180 (90-200)	220 (120-300)
P4	PMX5/PMX6/PMX8-EB25	0,10-0,20	0,10-0,30	0,80-1,80	1,00-2,40	1,20-3,00	20 (10-25)	50 (30-80)	60 (30-120)	120 (80-150)	180 (90-200)
P5	PMX5/PMX6/PMX8-EB25	0,10-0,20	0,10-0,30	0,80-1,80	1,00-2,40	1,20-3,00	20 (10-25)	50 (30-80)	60 (30-120)	120 (80-150)	180 (90-200)
P6	PMX5/PMX6/PMX8-EB25	0,10-0,20	0,10-0,30	0,80-1,80	1,00-2,40	1,20-3,00	20 (10-25)	50 (30-80)	60 (30-120)	120 (80-150)	180 (90-200)
P7	PMX5/PMX6/PMX8-EB25	0,10-0,20	0,10-0,30	0,80-1,80	1,00-2,40	1,20-3,00	20 (10-25)	50 (30-80)	60 (30-120)	120 (80-150)	180 (90-200)
M1	PMX5/PMX6/PMX8-EB25	0,08-0,15	0,10-0,20	0,80-1,20	1,00-2,00	1,20-2,50	-	25 (15-40)	35 (20-70)	-	-
K1	PMX5/PMX6/PMX8-EB25	0,10-0,20	0,10-0,25	0,80-2,20	1,00-2,80	1,20-3,50	25 (15-30)	60 (40-100)	80 (30-150)	-	220 (120-300)
K2	PMX5/PMX6/PMX8-EB25	0,10-0,20	0,10-0,25	0,80-1,80	1,00-2,40	1,20-3,00	-	25 (20-40)	40 (30-70)	-	80 (50-100)
K3	PMX5/PMX6/PMX8-EB25	0,10-0,20	0,10-0,25	0,80-2,20	1,00-2,80	1,20-3,50	25 (15-30)	60 (40-100)	80 (30-150)	-	220 (120-300)
K4	PMX5/PMX6/PMX8-EB25	0,10-0,20	0,10-0,25	0,80-2,20	1,00-2,80	1,20-3,50	25 (15-30)	45 (30-70)	70 (40-120)	100 (70-150)	150 (80-200)
K5	PMX5/PMX6/PMX8-EB25	0,10-0,20	0,10-0,25	0,80-2,20	1,00-2,80	1,20-3,50	25 (15-30)	45 (30-70)	70 (40-120)	100 (70-150)	150 (80-200)
K6	PMX5/PMX6/PMX8-EB25	0,10-0,20	0,10-0,25	0,80-1,80	1,00-2,40	1,20-3,00	-	60 (40-100)	80 (30-150)	-	220 (120-300)
K7	PMX5/PMX6/PMX8-EB25	0,10-0,20	0,10-0,25	0,80-1,80	1,00-2,40	1,20-3,00	-	60 (40-100)	80 (30-150)	-	220 (120-300)
N1	PMX5/PMX6/PMX8-EB25	0,10-0,20	0,10-0,30	0,80-2,20	1,00-2,80	1,20-3,50	50 (30-100)	-	-	-	-
N2	PMX5/PMX6/PMX8-EB25	0,10-0,20	0,10-0,30	0,80-2,20	1,00-2,80	1,20-3,50	50 (30-100)	-	-	-	-
N3	PMX5/PMX6/PMX8-EB25	0,10-0,20	0,10-0,30	0,80-2,20	1,00-2,80	1,20-3,50	50 (30-100)	-	-	-	-
N11	PMX5/PMX6/PMX8-EB25	0,10-0,20	0,10-0,30	0,80-2,20	1,00-2,80	1,20-3,50	50 (30-100)	-	-	-	-
PM1	PMX5/PMX6/PMX8-EB25	0,10-0,20	0,10-0,30	0,50-1,80	0,80-2,00	1,00-2,50	-	50 (30-80)	70 (40-100)	-	-
PM2	PMX5/PMX6/PMX8-EB25	0,10-0,20	0,10-0,30	0,50-1,80	0,80-2,00	1,00-2,50	-	50 (30-80)	70 (40-100)	-	-
PM3	PMX5/PMX6/PMX8-EB25	0,10-0,20	0,10-0,30	0,50-1,80	0,80-2,00	1,00-2,50	-	50 (30-80)	70 (40-100)	-	-

Cutting data – PM Plus...-EB45

SMG		a _p (Ø)			f			v _c				
		z=6	z=8	z=6	z=8	z=10	H15	CP20	RX2000	CF	RX1500	
P1	PMX5/PMX6/PMX8-EB45	0,10-0,20	0,10-0,30	0,30-0,90	0,40-1,20	0,50-1,50	25 (15-30)	60 (30-100)	80 (30-150)	180 (90-200)	220 (120-300)	
P2	PMX5/PMX6/PMX8-EB45	0,10-0,20	0,10-0,30	0,30-0,90	0,40-1,20	0,50-1,50	25 (15-30)	60 (30-100)	80 (30-150)	180 (90-200)	220 (120-300)	
P3	PMX5/PMX6/PMX8-EB45	0,10-0,20	0,10-0,30	0,30-0,90	0,40-1,20	0,50-1,50	25 (15-30)	60 (30-100)	80 (30-150)	180 (90-200)	220 (120-300)	
P4	PMX5/PMX6/PMX8-EB45	0,10-0,20	0,10-0,30	0,20-0,70	0,30-1,00	0,40-1,20	20 (10-25)	50 (30-80)	60 (30-120)	120 (80-150)	180 (90-200)	
P5	PMX5/PMX6/PMX8-EB45	0,10-0,20	0,10-0,30	0,20-0,70	0,30-1,00	0,40-1,20	20 (10-25)	50 (30-80)	60 (30-120)	120 (80-150)	180 (90-200)	
P6	PMX5/PMX6/PMX8-EB45	0,10-0,20	0,10-0,30	0,20-0,70	0,30-1,00	0,40-1,20	20 (10-25)	50 (30-80)	60 (30-120)	120 (80-150)	180 (90-200)	
P7	PMX5/PMX6/PMX8-EB45	0,10-0,20	0,10-0,30	0,20-0,70	0,30-1,00	0,40-1,20	20 (10-25)	50 (30-80)	60 (30-120)	120 (80-150)	180 (90-200)	
P8	PMX5/PMX6/PMX8-EB45	0,10-0,20	0,10-0,30	0,20-0,70	0,30-1,00	0,40-1,20	15 (10-20)	35 (20-60)	40 (20-80)	80 (60-120)	120 (80-180)	
P11	PMX5/PMX6/PMX8-EB45	0,10-0,20	0,10-0,30	0,20-0,70	0,30-1,00	0,40-1,20	15 (10-20)	35 (20-60)	40 (20-80)	80 (60-120)	120 (80-180)	
P12	PMX5/PMX6/PMX8-EB45	0,10-0,20	0,10-0,30	0,20-0,70	0,30-1,00	0,40-1,20	12 (8-15)	25 (15-45)	30 (15-65)	65 (45-95)	95 (65-145)	
M1	PMX5/PMX6/PMX8-EB45	0,08-0,15	0,10-0,20	0,20-0,60	0,30-0,80	0,40-1,00	12 (9-15)	25 (15-40)	35 (20-70)	-	-	
M2	PMX5/PMX6/PMX8-EB45	0,08-0,15	0,10-0,20	0,20-0,60	0,30-0,80	0,40-1,00	-	25 (15-40)	35 (20-70)	-	-	
M3	PMX5/PMX6/PMX8-EB45	0,08-0,15	0,10-0,20	0,20-0,60	0,30-0,80	0,40-1,00	-	25 (15-40)	35 (20-70)	-	-	
M4	PMX5/PMX6/PMX8-EB45	0,08-0,15	0,10-0,20	0,20-0,60	0,30-0,80	0,40-1,00	-	20 (10-30)	25 (15-50)	-	-	
M5	PMX5/PMX6/PMX8-EB45	0,08-0,15	0,10-0,20	0,20-0,60	0,30-0,80	0,40-1,00	-	20 (10-30)	25 (15-50)	-	-	
K1	PMX5/PMX6/PMX8-EB45	0,10-0,20	0,10-0,25	0,30-0,90	0,40-1,20	0,50-1,50	25 (15-30)	60 (40-100)	80 (30-150)	-	220 (120-300)	
K2	PMX5/PMX6/PMX8-EB45	0,10-0,20	0,10-0,25	0,30-0,90	0,40-1,20	0,50-1,50	-	25 (20-40)	40 (30-70)	-	80 (50-100)	
K3	PMX5/PMX6/PMX8-EB45	0,10-0,20	0,10-0,25	0,30-0,90	0,40-1,20	0,50-1,50	25 (15-30)	60 (40-100)	80 (30-150)	-	220 (120-300)	
K4	PMX5/PMX6/PMX8-EB45	0,10-0,20	0,10-0,25	0,30-0,90	0,40-1,20	0,50-1,50	25 (15-30)	45 (30-70)	70 (40-120)	100 (70-150)	150 (80-200)	
K5	PMX5/PMX6/PMX8-EB45	0,10-0,20	0,10-0,25	0,30-0,90	0,40-1,20	0,50-1,50	25 (15-30)	45 (30-70)	70 (40-120)	100 (70-150)	150 (80-200)	
K6	PMX5/PMX6/PMX8-EB45	0,10-0,20	0,10-0,25	0,30-0,90	0,40-1,20	0,50-1,50	-	60 (40-100)	80 (30-150)	-	220 (120-300)	
K7	PMX5/PMX6/PMX8-EB45	0,10-0,20	0,10-0,25	0,30-0,90	0,40-1,20	0,50-1,50	-	60 (40-100)	80 (30-150)	-	220 (120-300)	
N1	PMX5/PMX6/PMX8-EB45	0,10-0,20	0,10-0,30	0,30-0,90	0,40-1,20	0,50-1,50	50 (30-100)	-	80 (30-150)	-	-	
N2	PMX5/PMX6/PMX8-EB45	0,10-0,20	0,10-0,30	0,30-0,90	0,40-1,20	0,50-1,50	50 (30-100)	-	80 (30-150)	-	-	
N3	PMX5/PMX6/PMX8-EB45	0,10-0,20	0,10-0,30	0,30-0,90	0,40-1,20	0,50-1,50	50 (30-100)	-	80 (30-150)	-	-	
N11	PMX5/PMX6/PMX8-EB45	0,10-0,20	0,10-0,30	0,30-0,90	0,40-1,20	0,50-1,50	50 (30-100)	-	80 (30-150)	-	-	
S1	PMX5/PMX6/PMX8-EB45	0,08-0,15	0,10-0,15	0,20-0,60	0,30-0,80	0,40-1,00	-	20 (10-25)	20 (10-25)	-	-	
S2	PMX5/PMX6/PMX8-EB45	0,08-0,15	0,10-0,15	0,20-0,60	0,30-0,80	0,40-1,00	-	20 (10-25)	20 (10-25)	-	-	
S3	PMX5/PMX6/PMX8-EB45	0,08-0,15	0,10-0,15	0,20-0,60	0,30-0,80	0,40-1,00	-	20 (10-25)	20 (10-25)	-	-	
S11	PMX5/PMX6/PMX8-EB45	0,08-0,15	0,10-0,15	0,20-0,60	0,30-0,80	0,40-1,00	20 (15-30)	30 (15-40)	40 (20-50)	-	-	
S12	PMX5/PMX6/PMX8-EB45	0,08-0,15	0,10-0,15	0,20-0,60	0,30-0,80	0,40-1,00	20 (15-30)	30 (15-40)	40 (20-50)	-	-	
S13	PMX5/PMX6/PMX8-EB45	0,08-0,15	0,10-0,15	0,20-0,60	0,30-0,80	0,40-1,00	20 (15-30)	30 (15-40)	40 (20-50)	-	-	
H3	PMX5/PMX6/PMX8-EB45	0,08-0,15	0,10-0,15	0,20-0,40	0,30-0,60	0,40-0,75	-	-	10 (8-15)	-	-	
H5	PMX5/PMX6/PMX8-EB45	0,08-0,15	0,10-0,15	0,20-0,40	0,30-0,60	0,40-0,75	-	-	10 (8-15)	-	-	
H7	PMX5/PMX6/PMX8-EB45	0,08-0,15	0,10-0,15	0,20-0,40	0,30-0,60	0,40-0,75	-	-	10 (8-15)	-	-	
H8	PMX5/PMX6/PMX8-EB45	0,08-0,15	0,10-0,15	0,20-0,40	0,30-0,60	0,40-0,75	-	-	10 (8-15)	-	-	
H11	PMX5/PMX6/PMX8-EB45	0,08-0,15	0,10-0,15	0,20-0,40	0,30-0,60	0,40-0,75	-	-	10 (8-15)	-	-	
H12	PMX5/PMX6/PMX8-EB45	0,08-0,15	0,10-0,15	0,20-0,40	0,30-0,60	0,40-0,75	-	-	10 (8-15)	-	-	
H21	PMX5/PMX6/PMX8-EB45	0,08-0,15	0,10-0,15	0,20-0,40	0,30-0,60	0,40-0,75	-	-	10 (8-15)	-	-	
H31	PMX5/PMX6/PMX8-EB45	0,08-0,15	0,10-0,15	0,20-0,40	0,30-0,60	0,40-0,75	-	-	10 (8-15)	-	-	
PM1	PMX5/PMX6/PMX8-EB45	0,10-0,20	0,10-0,30	0,30-0,90	0,40-1,20	0,50-1,50	-	50 (30-80)	70 (40-100)	-	-	
PM2	PMX5/PMX6/PMX8-EB45	0,10-0,20	0,10-0,30	0,30-0,90	0,40-1,20	0,50-1,50	-	50 (30-80)	70 (40-100)	-	-	
PM3	PMX5/PMX6/PMX8-EB45	0,10-0,20	0,10-0,30	0,30-0,90	0,40-1,20	0,50-1,50	-	50 (30-80)	70 (40-100)	-	-	
TS1	PMX5/PMX6/PMX8-EB45	0,10-0,15	0,10-0,20	0,30-0,90	0,40-1,20	0,50-1,50	20 (15-25)	-	40 (20-60)	-	-	
TS2	PMX5/PMX6/PMX8-EB45	0,10-0,15	0,10-0,20	0,30-0,90	0,40-1,20	0,50-1,50	20 (15-25)	-	40 (20-60)	-	-	
TS3	PMX5/PMX6/PMX8-EB45	0,10-0,15	0,10-0,20	0,30-0,90	0,40-1,20	0,50-1,50	20 (15-25)	-	40 (20-60)	-	-	
TS4	PMX5/PMX6/PMX8-EB45	0,10-0,15	0,10-0,20	0,30-0,90	0,40-1,20	0,50-1,50	20 (15-25)	-	40 (20-60)	-	-	
TP1	PMX5/PMX6/PMX8-EB45	0,10-0,15	0,10-0,20	0,30-0,90	0,40-1,20	0,50-1,50	20 (15-25)	-	40 (20-60)	-	-	
TP2	PMX5/PMX6/PMX8-EB45	0,10-0,15	0,10-0,20	0,30-0,90	0,40-1,20	0,50-1,50	20 (15-25)	-	40 (20-60)	-	-	
TP3	PMX5/PMX6/PMX8-EB45	0,10-0,15	0,10-0,20	0,30-0,90	0,40-1,20	0,50-1,50	20 (15-25)	-	40 (20-60)	-	-	
TP4	PMX5/PMX6/PMX8-EB45	0,10-0,15	0,10-0,20	0,30-0,90	0,40-1,20	0,50-1,50	20 (15-25)	-	40 (20-60)	-	-	
GR1	PMX5/PMX6/PMX8-EB45	0,10-0,30	0,10-0,40	0,30-0,90	0,40-1,20	0,50-1,50	40 (80-20)	-	60 (30-120)	-	-	

SMG = Seco material group

a_p = mm

f = mm/rev

v_c = m/min

All cutting data are start values

Cutting data – PM Plus...-EB45

SMG		a _p (Ø)		f			v _c			
		z=6	z=8 /z=10	z=6	z=8	z=10	RN2010	RM2020	RM2090	RS2090
M1	PMX5/PMX6/PMX8-EB45	0,08-0,15	0,10-0,20	0,20-0,60	0,30-0,80	0,35-1,00	-	25 (15-40)	40 (25-80)	-
M2	PMX5/PMX6/PMX8-EB45	0,08-0,15	0,10-0,20	0,20-0,60	0,30-0,80	0,35-1,00	-	25 (15-40)	40 (25-80)	-
M3	PMX5/PMX6/PMX8-EB45	0,08-0,15	0,10-0,20	0,20-0,60	0,30-0,80	0,35-1,00	-	25 (15-40)	40 (25-80)	-
M4	PMX5/PMX6/PMX8-EB45	0,08-0,15	0,10-0,20	0,20-0,60	0,30-0,80	0,35-1,00	-	20 (10-30)	30 (20-60)	-
M5	PMX5/PMX6/PMX8-EB45	0,08-0,15	0,10-0,20	0,20-0,60	0,30-0,80	0,35-1,00	-	20 (10-30)	30 (20-60)	-
N1	PMX5/PMX6/PMX8-EB45	0,10-0,20	0,10-0,30	0,30-0,90	0,40-1,20	0,50-1,50	50 (30-100)	-	-	-
N2	PMX5/PMX6/PMX8-EB45	0,10-0,20	0,10-0,30	0,30-0,90	0,40-1,20	0,50-1,50	50 (30-100)	-	-	-
N3	PMX5/PMX6/PMX8-EB45	0,10-0,20	0,10-0,30	0,30-0,90	0,40-1,20	0,50-1,50	50 (30-100)	-	-	-
N11	PMX5/PMX6/PMX8-EB45	0,10-0,20	0,10-0,30	0,30-0,90	0,40-1,20	0,50-1,50	50 (30-100)	-	-	-
S1	PMX5/PMX6/PMX8-EB45	0,08-0,15	0,10-0,15	0,20-0,60	0,30-0,80	0,35-1,00	-	-	-	25 (12-30)
S2	PMX5/PMX6/PMX8-EB45	0,08-0,15	0,10-0,15	0,20-0,60	0,30-0,80	0,35-1,00	-	-	-	25 (12-30)
S3	PMX5/PMX6/PMX8-EB45	0,08-0,15	0,10-0,15	0,20-0,60	0,30-0,80	0,35-1,00	-	-	-	25 (12-30)
S11	PMX5/PMX6/PMX8-EB45	0,08-0,15	0,10-0,15	0,20-0,60	0,30-0,80	0,35-1,00	-	-	-	50 (25-65)
S12	PMX5/PMX6/PMX8-EB45	0,08-0,15	0,10-0,15	0,20-0,60	0,30-0,80	0,35-1,00	-	-	-	50 (25-65)
S13	PMX5/PMX6/PMX8-EB45	0,08-0,15	0,10-0,15	0,20-0,60	0,30-0,80	0,35-1,00	-	-	-	50 (25-65)

Cutting data – PM Plus...-EB845

SMG		a _p (Ø)		f			v _c		
		z=6	z=8 /z=10	z=6	z=8	z=10	RM2020	RM2090	RS2090
M1	PMX5/PMX6/PMX8-EB845	0,08-0,15	0,10-0,20	0,20-0,60	0,30-0,80	0,35-1,00	25 (15-40)	35 (20-70)	-
M2	PMX5/PMX6/PMX8-EB845	0,08-0,15	0,10-0,20	0,20-0,60	0,30-0,80	0,35-1,00	25 (15-40)	35 (20-70)	-
M3	PMX5/PMX6/PMX8-EB845	0,08-0,15	0,10-0,20	0,20-0,60	0,30-0,80	0,35-1,00	25 (15-40)	35 (20-70)	-
M4	PMX5/PMX6/PMX8-EB845	0,08-0,15	0,10-0,20	0,20-0,60	0,30-0,80	0,35-1,00	20 (10-30)	25 (15-50)	-
M5	PMX5/PMX6/PMX8-EB845	0,08-0,15	0,10-0,20	0,20-0,60	0,30-0,80	0,35-1,00	20 (10-30)	25 (15-50)	-
S1	PMX5/PMX6/PMX8-EB845	0,08-0,15	0,10-0,15	0,20-0,60	0,30-0,80	0,35-1,00	-	-	25 (12-30)
S2	PMX5/PMX6/PMX8-EB845	0,08-0,15	0,10-0,15	0,20-0,60	0,30-0,80	0,35-1,00	-	-	25 (12-30)
S3	PMX5/PMX6/PMX8-EB845	0,08-0,15	0,10-0,15	0,20-0,60	0,30-0,80	0,35-1,00	-	-	25 (12-30)
S11	PMX5/PMX6/PMX8-EB845	0,08-0,15	0,10-0,15	0,20-0,60	0,30-0,80	0,35-1,00	-	-	50 (25-65)
S12	PMX5/PMX6/PMX8-EB845	0,08-0,15	0,10-0,15	0,20-0,60	0,30-0,80	0,35-1,00	-	-	50 (25-65)
S13	PMX5/PMX6/PMX8-EB845	0,08-0,15	0,10-0,15	0,20-0,60	0,30-0,80	0,35-1,00	-	-	50 (25-65)

SMG = Seco material group
a_p = mm
f = mm/rev
v_c = m/min
All cutting data are start values

Heads for through holes Custom design $\varnothing 7,75-60,500$ mm

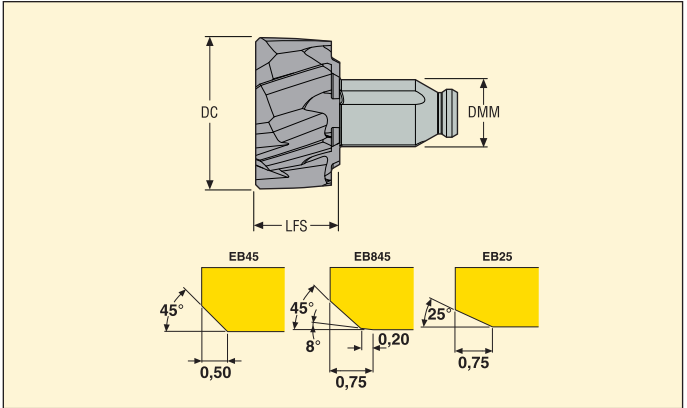

- For cutting data see page(s) 253
- For choice of geometry EB45, EB845 or EB25, please see page(s) 241

DC	Designation	Dimensions in mm			Body size	Geometries			Grades								
		LFS	DMM			EB45	EB845	EB25	H15	CP20	RX2000	CF	RX1500	RM2010	RM2020	RM2090	RS2090
7,75-9,999	PMX6-xx-xxx-xxxx	6	4,5	6	PMX05-xx	<input type="checkbox"/>	<input type="checkbox"/>	<input type="checkbox"/>	<input type="checkbox"/>	<input type="checkbox"/>	<input type="checkbox"/>	<input type="checkbox"/>	<input type="checkbox"/>	<input type="checkbox"/>	<input type="checkbox"/>	<input type="checkbox"/>	<input type="checkbox"/>
10,0-14,499	PMX6-xx-xxx-xxxx	7	6	6	PMX06-xx	<input type="checkbox"/>	<input type="checkbox"/>	<input type="checkbox"/>	<input type="checkbox"/>	<input type="checkbox"/>	<input type="checkbox"/>	<input type="checkbox"/>	<input type="checkbox"/>	<input type="checkbox"/>	<input type="checkbox"/>	<input type="checkbox"/>	<input type="checkbox"/>
14,5-21,499	PMX6-xx-xxx-xxxx	10	8	6	PMX08-xx	<input type="checkbox"/>	<input type="checkbox"/>	<input type="checkbox"/>	<input type="checkbox"/>	<input type="checkbox"/>	<input type="checkbox"/>	<input type="checkbox"/>	<input type="checkbox"/>	<input type="checkbox"/>	<input type="checkbox"/>	<input type="checkbox"/>	<input type="checkbox"/>
21,5-32,499	PMX6-xx-xxx-xxxx	12	12	8	PMX12-xx	<input type="checkbox"/>	<input type="checkbox"/>	<input type="checkbox"/>	<input type="checkbox"/>	<input type="checkbox"/>	<input type="checkbox"/>	<input type="checkbox"/>	<input type="checkbox"/>	<input type="checkbox"/>	<input type="checkbox"/>	<input type="checkbox"/>	<input type="checkbox"/>
32,5-60,500	PMX6-xx-xxx-xxxx	14	16	10	PMX16-xx	<input type="checkbox"/>	<input type="checkbox"/>	<input type="checkbox"/>	<input type="checkbox"/>	<input type="checkbox"/>	<input type="checkbox"/>	<input type="checkbox"/>	<input type="checkbox"/>	<input type="checkbox"/>	<input type="checkbox"/>	<input type="checkbox"/>	<input type="checkbox"/>
						<input type="checkbox"/>	<input type="checkbox"/>	<input type="checkbox"/>	<input type="checkbox"/>	<input type="checkbox"/>	<input type="checkbox"/>	<input type="checkbox"/>	<input type="checkbox"/>	<input type="checkbox"/>	<input type="checkbox"/>	<input type="checkbox"/>	<input type="checkbox"/>
						<input type="checkbox"/>	<input type="checkbox"/>	<input type="checkbox"/>	<input type="checkbox"/>	<input type="checkbox"/>	<input type="checkbox"/>	<input type="checkbox"/>	<input type="checkbox"/>	<input type="checkbox"/>	<input type="checkbox"/>	<input type="checkbox"/>	<input type="checkbox"/>
						<input type="checkbox"/>	<input type="checkbox"/>	<input type="checkbox"/>	<input type="checkbox"/>	<input type="checkbox"/>	<input type="checkbox"/>	<input type="checkbox"/>	<input type="checkbox"/>	<input type="checkbox"/>	<input type="checkbox"/>	<input type="checkbox"/>	<input type="checkbox"/>
						<input type="checkbox"/>	<input type="checkbox"/>	<input type="checkbox"/>	<input type="checkbox"/>	<input type="checkbox"/>	<input type="checkbox"/>	<input type="checkbox"/>	<input type="checkbox"/>	<input type="checkbox"/>	<input type="checkbox"/>	<input type="checkbox"/>	<input type="checkbox"/>
						<input type="checkbox"/>	<input type="checkbox"/>	<input type="checkbox"/>	<input type="checkbox"/>	<input type="checkbox"/>	<input type="checkbox"/>	<input type="checkbox"/>	<input type="checkbox"/>	<input type="checkbox"/>	<input type="checkbox"/>	<input type="checkbox"/>	<input type="checkbox"/>
						<input type="checkbox"/>	<input type="checkbox"/>	<input type="checkbox"/>	<input type="checkbox"/>	<input type="checkbox"/>	<input type="checkbox"/>	<input type="checkbox"/>	<input type="checkbox"/>	<input type="checkbox"/>	<input type="checkbox"/>	<input type="checkbox"/>	<input type="checkbox"/>
						<input type="checkbox"/>	<input type="checkbox"/>	<input type="checkbox"/>	<input type="checkbox"/>	<input type="checkbox"/>	<input type="checkbox"/>	<input type="checkbox"/>	<input type="checkbox"/>	<input type="checkbox"/>	<input type="checkbox"/>	<input type="checkbox"/>	<input type="checkbox"/>
						<input type="checkbox"/>	<input type="checkbox"/>	<input type="checkbox"/>	<input type="checkbox"/>	<input type="checkbox"/>	<input type="checkbox"/>	<input type="checkbox"/>	<input type="checkbox"/>	<input type="checkbox"/>	<input type="checkbox"/>	<input type="checkbox"/>	<input type="checkbox"/>
						<input type="checkbox"/>	<input type="checkbox"/>	<input type="checkbox"/>	<input type="checkbox"/>	<input type="checkbox"/>	<input type="checkbox"/>	<input type="checkbox"/>	<input type="checkbox"/>	<input type="checkbox"/>	<input type="checkbox"/>	<input type="checkbox"/>	<input type="checkbox"/>
						<input type="checkbox"/>	<input type="checkbox"/>	<input type="checkbox"/>	<input type="checkbox"/>	<input type="checkbox"/>	<input type="checkbox"/>	<input type="checkbox"/>	<input type="checkbox"/>	<input type="checkbox"/>	<input type="checkbox"/>	<input type="checkbox"/>	<input type="checkbox"/>
						<input type="checkbox"/>	<input type="checkbox"/>	<input type="checkbox"/>	<input type="checkbox"/>	<input type="checkbox"/>	<input type="checkbox"/>	<input type="checkbox"/>	<input type="checkbox"/>	<input type="checkbox"/>	<input type="checkbox"/>	<input type="checkbox"/>	<input type="checkbox"/>
						<input type="checkbox"/>	<input type="checkbox"/>	<input type="checkbox"/>	<input type="checkbox"/>	<input type="checkbox"/>	<input type="checkbox"/>	<input type="checkbox"/>	<input type="checkbox"/>	<input type="checkbox"/>	<input type="checkbox"/>	<input type="checkbox"/>	<input type="checkbox"/>
						<input type="checkbox"/>	<input type="checkbox"/>	<input type="checkbox"/>	<input type="checkbox"/>	<input type="checkbox"/>	<input type="checkbox"/>	<input type="checkbox"/>	<input type="checkbox"/>	<input type="checkbox"/>	<input type="checkbox"/>	<input type="checkbox"/>	<input type="checkbox"/>
						<input type="checkbox"/>	<input type="checkbox"/>	<input type="checkbox"/>	<input type="checkbox"/>	<input type="checkbox"/>	<input type="checkbox"/>	<input type="checkbox"/>	<input type="checkbox"/>	<input type="checkbox"/>	<input type="checkbox"/>	<input type="checkbox"/>	<input type="checkbox"/>
						<input type="checkbox"/>	<input type="checkbox"/>	<input type="checkbox"/>	<input type="checkbox"/>	<input type="checkbox"/>	<input type="checkbox"/>	<input type="checkbox"/>	<input type="checkbox"/>	<input type="checkbox"/>	<input type="checkbox"/>	<input type="checkbox"/>	<input type="checkbox"/>

= Non stock standard. Subject to change refer to current price- and stock-list
 Note: When ordering Precimaster Plus reamers for intermediate diameters, please state diameter and tolerance of hole to be reamed.
 Ordering example: PMX6-16.515 P7-EB45 RM2020.



Heads for through and blind holes Custom design $\varnothing 7,75-60,500$ mm



- For cutting data see page(s) 253
- For choice of geometry EB45, EB845 or EB25, please see page(s) 241

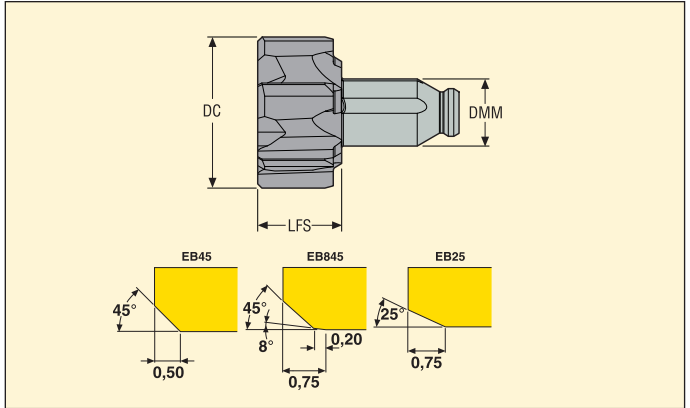

DC	Designation	Dimensions in mm			Body size	Geometries			Grades									
		LFS	DMM			EB45	EB845	EB25	H15	CP20	RX2000	CF	RX1500	RM2010	RM2020	RM2090	RS2090	
7,75-9,999	PMX5-xx-xxx-xxxx	6	4,5	6	PMX05-xx	<input type="checkbox"/>	<input type="checkbox"/>	<input type="checkbox"/>	<input type="checkbox"/>	<input type="checkbox"/>	<input type="checkbox"/>	<input type="checkbox"/>	<input type="checkbox"/>	<input type="checkbox"/>	<input type="checkbox"/>	<input type="checkbox"/>	<input type="checkbox"/>	<input type="checkbox"/>
10,0-14,499	PMX5-xx-xxx-xxxx	7	6	6	PMX06-xx	<input type="checkbox"/>	<input type="checkbox"/>	<input type="checkbox"/>	<input type="checkbox"/>	<input type="checkbox"/>	<input type="checkbox"/>	<input type="checkbox"/>	<input type="checkbox"/>	<input type="checkbox"/>	<input type="checkbox"/>	<input type="checkbox"/>	<input type="checkbox"/>	<input type="checkbox"/>
14,5-21,499	PMX5-xx-xxx-xxxx	10	8	6	PMX08-xx	<input type="checkbox"/>	<input type="checkbox"/>	<input type="checkbox"/>	<input type="checkbox"/>	<input type="checkbox"/>	<input type="checkbox"/>	<input type="checkbox"/>	<input type="checkbox"/>	<input type="checkbox"/>	<input type="checkbox"/>	<input type="checkbox"/>	<input type="checkbox"/>	<input type="checkbox"/>
21,5-32,499	PMX5-xx-xxx-xxxx	12	12	8	PMX12-xx	<input type="checkbox"/>	<input type="checkbox"/>	<input type="checkbox"/>	<input type="checkbox"/>	<input type="checkbox"/>	<input type="checkbox"/>	<input type="checkbox"/>	<input type="checkbox"/>	<input type="checkbox"/>	<input type="checkbox"/>	<input type="checkbox"/>	<input type="checkbox"/>	<input type="checkbox"/>
32,5-60,500	PMX5-xx-xxx-xxxx	14	16	10	PMX16-xx	<input type="checkbox"/>	<input type="checkbox"/>	<input type="checkbox"/>	<input type="checkbox"/>	<input type="checkbox"/>	<input type="checkbox"/>	<input type="checkbox"/>	<input type="checkbox"/>	<input type="checkbox"/>	<input type="checkbox"/>	<input type="checkbox"/>	<input type="checkbox"/>	<input type="checkbox"/>

= Non stock standard. Subject to change refer to current price- and stock-list
 Note: When ordering Precimaster Plus reamers for intermediate diameters, please state diameter and tolerance of hole to be reamed.
 Ordering example: PMX5-16.515 P7-EB45 RM2020.

Expandable heads for through and blind holes \varnothing 10-32,500 mm



- For cutting data see page(s) 253
- For choice of geometry EB45, EB845 or EB25, please see page(s) 241

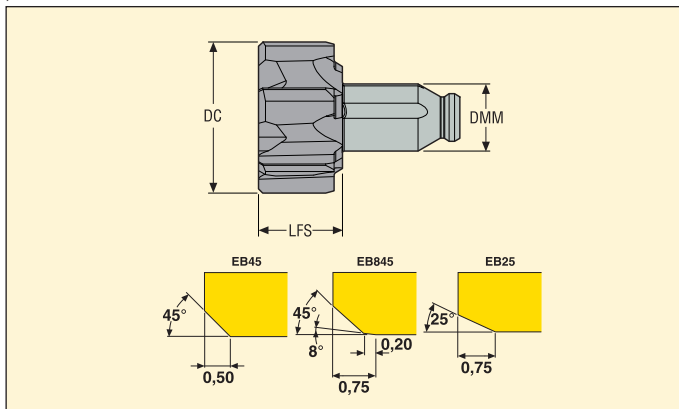

DC	Designation	Dimensions in mm			Body size	Geometries			Grades								
		LFS	DMM			EB45	EB845	EB25	H15	CP20	RX2000	CF	RX1500	RM2010	RM2020	RM2090	RS2090
10-14,499	PMX8-xx-xxx-xxxx	7	6	6	PMX06-xx	<input type="checkbox"/>	<input type="checkbox"/>	<input type="checkbox"/>	<input type="checkbox"/>	<input type="checkbox"/>	<input type="checkbox"/>	<input type="checkbox"/>	<input type="checkbox"/>	<input type="checkbox"/>	<input type="checkbox"/>	<input type="checkbox"/>	<input type="checkbox"/>
14,5-21,499	PMX8-xx-xxx-xxxx	10	8	6	PMX08-xx	<input type="checkbox"/>	<input type="checkbox"/>	<input type="checkbox"/>	<input type="checkbox"/>	<input type="checkbox"/>	<input type="checkbox"/>	<input type="checkbox"/>	<input type="checkbox"/>	<input type="checkbox"/>	<input type="checkbox"/>	<input type="checkbox"/>	<input type="checkbox"/>
21,5-32,499	PMX8-xx-xxx-xxxx	12	12	8	PMX12-xx	<input type="checkbox"/>	<input type="checkbox"/>	<input type="checkbox"/>	<input type="checkbox"/>	<input type="checkbox"/>	<input type="checkbox"/>	<input type="checkbox"/>	<input type="checkbox"/>	<input type="checkbox"/>	<input type="checkbox"/>	<input type="checkbox"/>	<input type="checkbox"/>

= Non stock standard. Subject to change refer to current price- and stock-list
 Note: When ordering Precimaster Plus reamers for intermediate diameters, please state diameter and tolerance of hole to be reamed.
 Ordering example: PMX8-16.515 P7-EB45 RM2020.

No waiting for quotations – Short delivery time

Custom Design is also available for Precimaster Plus reamers and tool holders.

You can now quote for your own intermediate \varnothing reamer and tailor made Precimaster Plus tool holder using the Seco Custom Design software.

Easy to use concept: Just indicate component min/max \varnothing or use ISO tolerance system available in the software.

Precimaster Plus head designation is created automatically.

Custom Design gives you a number of advantages:

- No waiting for quotations! Price and delivery time available instantly!
- Directly visualises your needs. No risk of misunderstandings
- Short delivery time

The screenshot displays the SECO CUSTOM DESIGN software interface. At the top, it shows the SECO logo, the title 'CUSTOM DESIGN', and the version '1.8.2.1'. The breadcrumb navigation is 'Reaming >> Precimaster Plus >> Precimaster Plus Cutting Heads'. There are links for 'Back', 'Start Page', 'Login', and 'English'. A 'Print this page' icon is also present.

The main content area is titled 'Step 1: Tool Specification' and 'Step 2: Request for Quotation'. On the left, there is a 3D model of a reamer tool with a yellow cutting edge. A callout shows a cross-section of the cutting edge with a lead angle of 45° and a width of $0.50\text{mm} / 0.0197''$. The cutting edge is labeled 'EB45'. Below the model, a diagram shows the reamer's diameter range with labels 'D', 'D_{MIN}', and 'D_{MAX}'.

On the right, there is a 'Request for Quotation' form. It includes a 'Material cutting choice' dropdown set to 'S2 / Co-based super alloys', a 'Work piece' dropdown set to 'C. Crossing hole PMX6', and a 'Tolerance' dropdown set to 'Custom'. Below these are input fields for 'Workpiece Diameter Minimum Dmin' (9.9 to 60.469, value 30.5), 'Workpiece Diameter Maximum Dmax' (30.516 to 30.6, value 30.525), 'Geometry' (EB45), and 'Grade' (RS2090). A note states: 'Reamer diameter Dc position : 45% of the workpiece tolerance' and 'Note : SECO recommend the using of an adapter to correct the run-out for your application'. There are 'Previous', 'Request quotation', and 'Spare Parts' buttons.

At the bottom right, there is a 'Designation' field containing 'PMX6-30.500/30.525EB45,RS2090' and a 'Delivery Time' section with 'Quantity: 2' and 'Min Quantity: 1', along with a 'Send request' button.

Please contact your local Seco representative for more information.

Troubleshooting

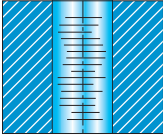
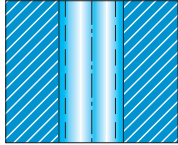
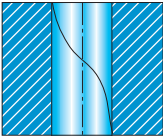
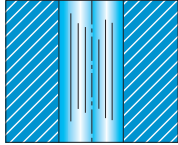
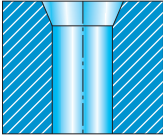
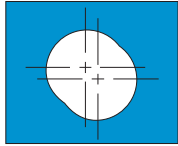
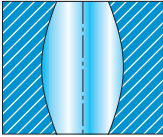
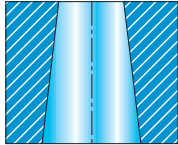
<p>Poor surface finish</p> <ul style="list-style-type: none"> • Check material allowance • Improve coolant conditions (outlet type, pressure, quality) • Reduce feed rate 	<p>Too large diameter</p> <ul style="list-style-type: none"> • Improve centring (part/tool) 
<p>Retraction marks</p> <ul style="list-style-type: none"> • Improve coolant conditions (outlet type, pressure, quality) • Improve centring (part/tool) • Reduce feed-out speed 	<p>Facets</p> <ul style="list-style-type: none"> • Improve centring (part/tool) • Check material allowance 
<p>Tapered entry</p> <ul style="list-style-type: none"> • Reduce feed rate • Improve centring (part/tool) • Reduce radial run-out 	<p>Off centre/Ovality</p> <ul style="list-style-type: none"> • Improve clamping (workpiece deformation) • Check material allowance • Improve centring (part/tool) 
<p>Deformed hole</p> <ul style="list-style-type: none"> • Improve clamping (workpiece deformation) 	<p>Tapered hole</p> <ul style="list-style-type: none"> • Improve centring (part/tool) 

Regrinding instructions for Precimaster Plus

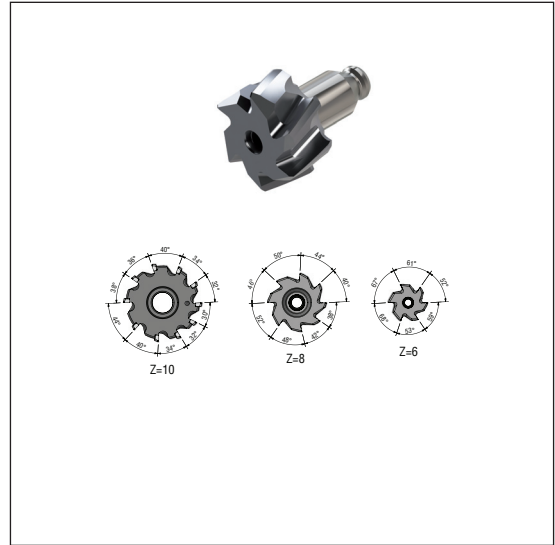
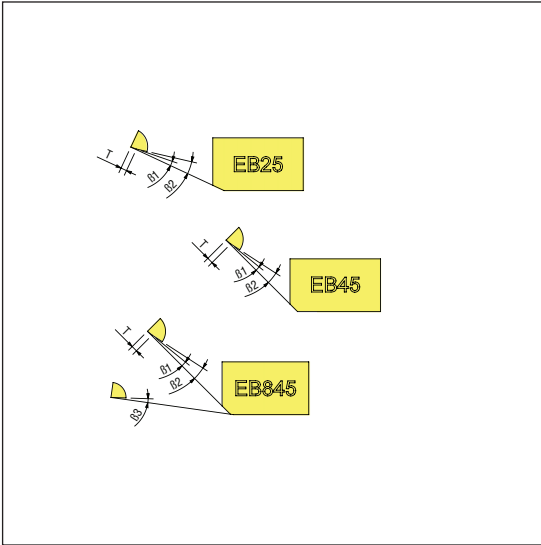

Ø Precimaster Plus	β_1	β_2	β_3	t
10,00–14,499	8°	18°	8°	15°
10,00–14,499	8°	18°	8°	0,20
14,500–21,499	8°	18°	8°	0,20
21,500–32,499	8°	18°	8°	0,25
32,500–60,499	8°	15°	8°	0,30

Specifications

Diamond grinding wheel

Grain size:

D6 – For first clearance angle (β_1 – β_3)

D64 – For second clearance angle (β_2)

Important:

Regrinding reduces reamer diameter

Recoating may produce oversized diameter

Recoating may cause driving pin loosening

Max run-out on lead chamfers 10 μ m



Range overview

Nanofix™	∅ Range	Reaming depth	Drill ∅ tolerance	Intermediate diameter	Surface finish (2)
	2,97-12,05 mm	5-12 x D	IT 7	Yes, available through Custom design	R _a 0,8–1,2 μm

Nanofix™ is a Seco solid carbide reamer programme dedicated for small ∅ from 2,97 to 12,05 mm.

Design includes a unique patented Quick-fit clamping system that will allow it to hold the entire diameter range with only 2 tool holders .

Tool holders have internal coolant with a simple adjustable system so the outlet style can be set for either through or blind bore, depending on application.

Quick-fit clamping

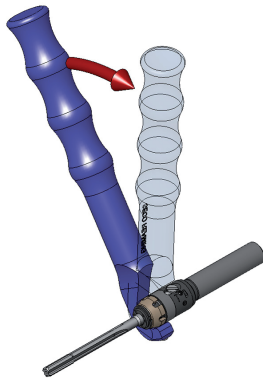

Quick and easy tool change.
Accurate repositioning in run-out and length.

2 Quick-fit sizes to cover the complete diameter range



Quick-fit \varnothing 10 mm for
 \varnothing 6,051-12,050 mm.



Quick-fit \varnothing 6 mm for
 \varnothing 2,97 -6,050 mm.

Same tool for blind or through hole application

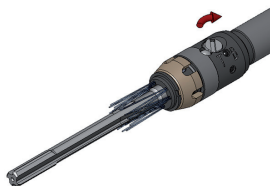

through



blind

Turn coolant style adjusting screw by 1/4 of a revolution to change coolant outlet from through to blind and vice-versa.

Code key - Reamers

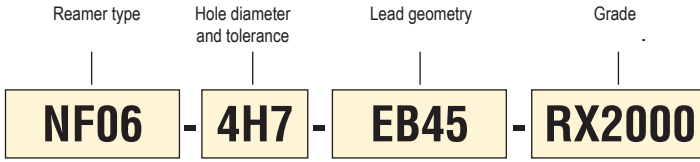

Code key - Intermediate diameter reamers

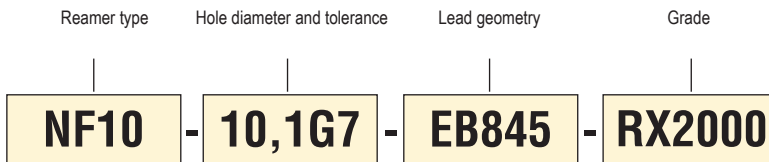

Code key - Shanks

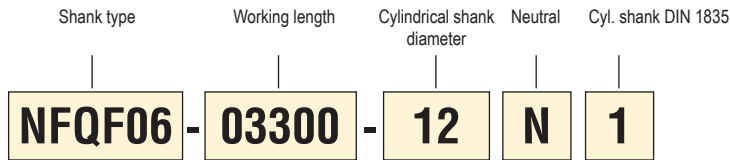

Run-out

Rotating tool

Max. run-out recommended: 5 µm.
 Precision holder is recommended : Hydraulic chuck, D-type collet chuck or 5672 collet chuck.

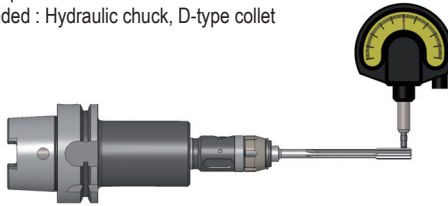

Note: due to coolant outlet adjustment sealing o-ring, the use of a Shrinkfit holder is not recommended.

Static tool

Use a Seco floating holder, see page 375-379.

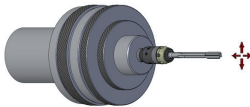

Floating holders allow reamer self-centering in pre-bore.

Coolant requirements

To reach maximum tool life and hole quality, the following coolant requirements should be observed.

Coolant through the tool is recommended.
 External coolant supply can be used with cutting condition reduced by 75%.

Soluble oil with 40% minimum mineral oil.
 Neat oil recommended for stainless steel.

Concentration minimum 6–8%.
 Filtration 30–50 µm.
 Volume min 0,5 l/min/mm in tool diameter (Ex: Reamer Ø10, min volume is 5 l/min).

Diameter measurement

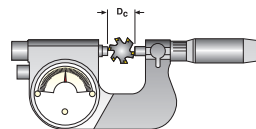
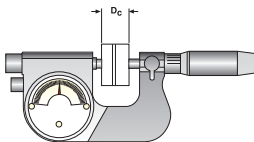

Gauge clock micrometer prior to Ø measurement.

Important!

Nanofix reamers have differential pitch on teeth.
 When measuring the diameter, make sure that you have 2 teeth 180° opposite.

Use clock micrometer and measuring blocks for gauging.

Lead geometries and grades – Applications

Lead geometry - EB45

Chip control +++
 Surface Finish + (R_a 0,8 - 1,2 μm)
 Versatile

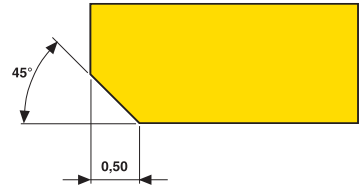

Lead geometry - EB845

Chip control ++
 Surface finish+++ (R_a 0,2 - 0,8 μm)

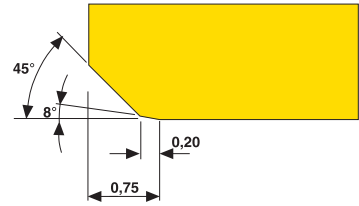

Lead geometry - EB25

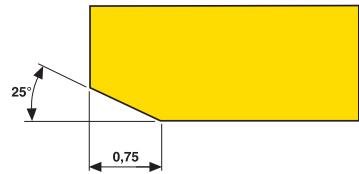

Feed performance +++
 Surface finish ++ (R_a 0,4 - 0,8 μm)
 Chip control +

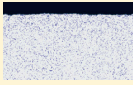

Grades

	H15	Uncoated A tough micrograin grade for all materials. Suitable for fine-reaming operations due to edge sharpness.
	RX2000	Coated High performance coated grade suitable for all materials.

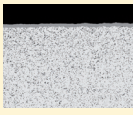
Grades

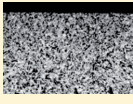
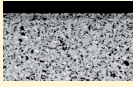
	RN2010	A sub-micrograin uncoated grade with optimized geometries for N-materials (non ferrous).
	RM2020	A tough coated grade suitable for fine reaming operation with optimized geometries for M materials.
	RM2090	A wear resistant coated grade with specific geometries for M materials. Optimisation in M materials.
	RS2090	A wear resistant coated grade with specific geometries for S materials. Optimisation in S materials.

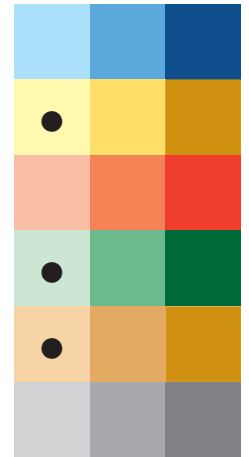

Reamer for blind and through holes \varnothing 2,97-6,00 mm

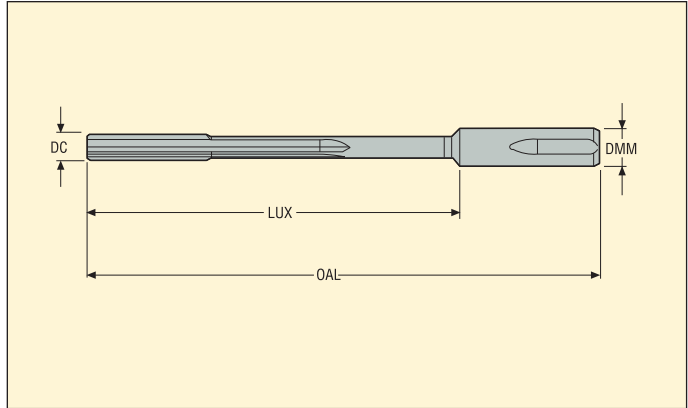

DC	Hole dia ISO (mm)	Hole dia min/max (mm)	Hole dia min/max (inch)	Seco drill size (mm)	Designation	Dimensions in mm					Geometries			Grades	
						\varnothing	LUX	DMM	OAL	Body size	EB45	EB845	EB25	RX2000	H15
2,97	2,97 H7	2,970/2,980	.1169/ .1173	2,8-2,9	NF06-2.97 H7-EB..	4	40	6	60	NFQF06...	■	□	□	02728852	□
2,98	2,98 H7	2,980/2,990	.1173/ .1177	2,8-2,9	NF06-2.98 H7-EB..	4	40	6	60	NFQF06...	■	□	□	02728853	□
2,99	2,99 H7/3 K7	2,990/3,000	.1177/ .1181	2,8-2,9	NF06-2.99 H7-EB..	4	40	6	60	NFQF06...	■	□	□	02728854	□
3,00	3 H7	3,000/3,010	.1181/ .1185	2,8-2,9	NF06-3 H7-EB..	4	40	6	60	NFQF06...	■	□	□	02728858	□
3,01	3,01 H7	3,010/3,022	.1185/ .1190	2,8-2,9	NF06-3.01 H7-EB..	4	40	6	60	NFQF06...	■	□	□	02728860	□
3,02	3,02 H7/3 D7	3,020/3,032	.1189/ .1194	2,9	NF06-3.02 H7-EB..	4	40	6	60	NFQF06...	■	□	□	02728862	□
3,03	3,03 H7	3,030/3,042	.1193/ .1198	2,9	NF06-3.03 H7-EB..	4	40	6	60	NFQF06...	■	□	□	02728864	□
3,04	3,04 H7/3D10	3,040/3,052	.1197/ .1202	2,9	NF06-3.04 H7-EB..	4	40	6	60	NFQF06...	■	□	□	02728865	□
3,05	3,05 H7	3,050/3,062	.1201/ .1206	2,9	NF06-3.05 H7-EB..	4	40	6	60	NFQF06...	■	□	□	02728866	□
3,167	3,167 H7	3,167/3,179	.1247/ .1252	3	NF06-3.167 H7-EB..	4	60	6	80	NFQF06...	■	□	□	02761485	□
3,175	3,175 H7	3,175/3,175	.1255/ .1250	3	NF06-3.175 H7-EB..	4	60	6	80	NFQF06...	■	□	□	02761489	□
3,49	3,49 H7	3,490/3,502	.1374/ .1379	3,3-3,4	NF06-3.49 H7-EB..	4	60	6	80	NFQF06...	■	□	□	02728867	□
3,50	3,5 H7	3,500/3,512	.1378/ .1383	3,3-3,4	NF06-3.5 H7-EB..	4	60	6	80	NFQF06...	■	□	□	02728868	□
3,51	3,51 H7	3,510/3,522	.1382/ .1387	3,3-3,4	NF06-3.51 H7-EB..	4	60	6	80	NFQF06...	■	□	□	02728869	□
3,52	3,52 H7	3,520/3,532	.1386/ .1391	3,3-3,4	NF06-3.52 H7-EB..	4	60	6	80	NFQF06...	■	□	□	02728870	□
3,97	3,97 H7	3,970/3,982	.1563/ .1568	3,8-3,9	NF06-3.97 H7-EB..	4	60	6	80	NFQF06...	■	□	□	02728871	□
3,98	3,98 H7/4 P7	3,980/3,992	.1567/ .1572	3,8-3,9	NF06-3.98 H7-EB..	4	60	6	80	NFQF06...	■	□	□	02728872	□
3,99	3,99 H7/4 K8	3,990/4,002	.1571/ .1576	3,8-3,9	NF06-3.99 H7-EB..	4	60	6	80	NFQF06...	■	□	□	02728873	□
4,00	4 H7	4,000/4,012	.1575/ .1580	3,8-3,9	NF06-4 H7-EB..	4	60	6	80	NFQF06...	■	□	□	02728874	□
4,01	4,01 H7/4 F7	4,010/4,022	.1579/ .1583	3,8-3,9	NF06-4.01 H7-EB..	4	60	6	80	NFQF06...	■	□	□	02728875	□
4,02	4,02 H7/4 E7	4,020/4,032	.1583/ .1587	3,9	NF06-4.02 H7-EB..	4	60	6	80	NFQF06...	■	□	□	02728876	□
4,03	4,03 H7/4 D7	4,030/4,042	.1587/ .1591	3,9	NF06-4.03 H7-EB..	4	60	6	80	NFQF06...	■	□	□	02728877	□
4,04	4,04 H7	4,040/4,052	.1591/ .1595	3,9	NF06-4.04 H7-EB..	4	60	6	80	NFQF06...	■	□	□	02728879	□
4,05	4,05 H7	4,050/4,062	.1594/ .1599	3,9	NF06-4.05 H7-EB..	4	60	6	80	NFQF06...	■	□	□	02728880	□
4,50	4,5 H7	4,500/4,512	.1772/ .1776	4,3-4,4	NF06-4.5 H7-EB..	4	60	6	80	NFQF06...	■	□	□	02728881	□
4,75	4,75 H7	4,752/4,750	.1875/ .1870	4,5	NF06-4.750 H7-EB..	4	60	6	80	NFQF06...	■	□	□	02761490	□
4,762	4,762 H7	4,774/4,762	.1880/ .1875	4,5	NF06-4.762 H7-EB..	4	60	6	80	NFQF06...	■	□	□	02761494	□
4,97	4,97 H7	4,970/4,982	.1957/ .1961	4,8-4,9	NF06-4.97 H7-EB..	4	60	6	80	NFQF06...	■	□	□	02728882	□
4,98	4,98 H7/5 P7	4,980/4,992	.1961/ .1965	4,8-4,9	NF06-4.98 H7-EB..	4	60	6	80	NFQF06...	■	□	□	02728883	□
4,99	4,99 H7/5 K8	4,990/5,002	.1965/ .1969	4,8-4,9	NF06-4.99 H7-EB..	4	60	6	80	NFQF06...	■	□	□	02728884	□
5,00	5 H7	5,000/5,012	.1969/ .1973	4,8-4,9	NF06-5 H7-EB..	4	60	6	80	NFQF06...	■	□	□	02728927	□
5,01	5,01 H7/5 F7	5,010/5,022	.1972/ .1977	4,8-4,9	NF06-5.01 H7-EB..	4	60	6	80	NFQF06...	■	□	□	02728928	□
5,02	5,02 H7/5 E7	5,020/5,032	.1976/ .1981	4,9	NF06-5.02 H7-EB..	4	60	6	80	NFQF06...	■	□	□	02728929	□
5,03	5,03 H7/5 D7	5,030/5,042	.1980/ .1985	4,9	NF06-5.03 H7-EB..	4	60	6	80	NFQF06...	■	□	□	02728930	□
5,04	5,04 H7	5,040/5,052	.1984/ .1989	4,9	NF06-5.04 H7-EB..	4	60	6	80	NFQF06...	■	□	□	02728931	□
5,05	5,05 H7	5,050/5,062	.1988/ .1993	4,9	NF06-5.05 H7-EB..	4	60	6	80	NFQF06...	■	□	□	02728932	□
5,50	5,5 H7	5,500/5,512	.2165/ .2170	5,3-5,4	NF06-5.5 H7-EB..	4	60	6	80	NFQF06...	■	□	□	02728933	□
5,97	5,97 H7	5,970/5,982	.2350/ .2355	5,8-5,9	NF06-5.97 H7-EB..	4	60	6	80	NFQF06...	■	□	□	02728934	□
5,98	5,98 H7/6 P7	5,980/5,992	.2354/ .2359	5,8-5,9	NF06-5.98 H7-EB..	4	60	6	80	NFQF06...	■	□	□	02728935	□
5,99	5,99 H7/6 K8	5,990/6,002	.2358/ .2363	5,8-5,9	NF06-5.99 H7-EB..	4	60	6	80	NFQF06...	■	□	□	02728936	□
6,00	6 H7	6,000/6,012	.2362/ .2367	5,8-5,9	NF06-6 H7-EB..	4	60	6	80	NFQF06...	■	□	□	02728937	□

■ Stock standard □ Non stock standard. Subject to change refer to current price- and stock-list.

Note: When ordering Nanofix reamers for intermediate diameters, please state diameter and tolerance of hole to be reamed.

Ordering example: NF10-10,18710,213-EB845, RX2000.

Reamer for blind and through holes $\varnothing 6,01-9,512$ mm

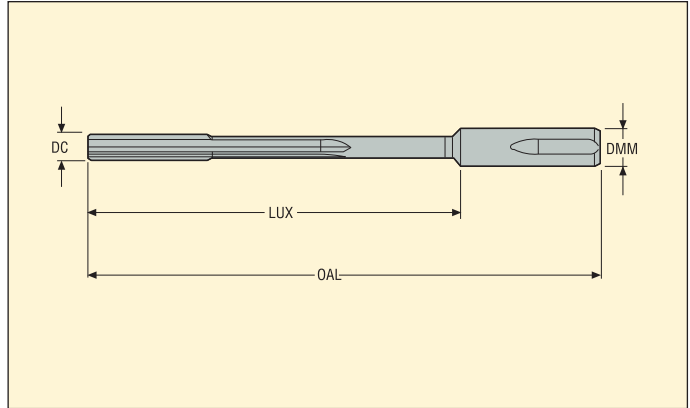

DC	Hole dia ISO (mm)	Hole dia min/max (mm)	Hole dia min/max (inch)	Seco drill size (mm)	Designation	Dimensions in mm				Geometries			Grades		
						\varnothing	LUX	DMM	OAL	Body size	EB45	EB845	EB25	RX2000	H15
6,01	6,01 H7/6 F7	6,010/6,025	.2366/ .2372	5,8-5,9	NF06-6.01 H7-EB..	4	60	6	80	NFQF06...	■	□	□	02728938	□
6,02	6,02 H7/6 E7	6,020/6,035	.2370/ .2376	5,9	NF06-6.02 H7-EB..	4	60	6	80	NFQF06...	■	□	□	02728939	□
6,03	6,03 H7/6 D7	6,030/6,045	.2374/ .2380	5,9	NF06-6.03 H7-EB..	4	60	6	80	NFQF06...	■	□	□	02728940	□
6,04	6,04 H7	6,040/6,055	.2378/ .2384	5,9	NF06-6.04 H7-EB..	4	60	6	80	NFQF06...	■	□	□	02728941	□
6,05	6,05 H7	6,050/6,065	.2382/ .2388	5,9	NF06-6.05 H7-EB..	4	60	6	80	NFQF06...	■	□	□	02728942	□
6,334	6,334 H7	6,334/6,349	.2494/ .2500	6,1-6,2	NF10-6.334 H7-EB..	6	83	10	115	NFQF10...	■	□	□	02761987	□
6,35	6,35 H7	6,35/6,365	.2500/ .2506	6,2	NF10-6.350 H7-EB..	6	83	10	115	NFQF10...	■	□	□	02762016	□
6,375	6,375 H7	6,375/6,39	.2510/ .2516	6,2	NF10-6.375 H7-EB..	6	83	10	115	NFQF10...	■	□	□	02762017	□
6,50	6,5 H7	6,500/6,515	.2559/ .2565	6,3-6,35-6,4	NF10-6.5 H7-EB..	6	83	10	115	NFQF10...	■	□	□	02728943	□
6,97	6,97 H7	6,970/6,985	.2744/ .2750	6,8-6,9	NF10-6.97 H7-EB..	6	83	10	115	NFQF10...	■	□	□	02728946	□
6,98	6,98 H7	6,980/6,995	.2748/ .2754	6,8-6,9	NF10-6.98 H7-EB..	6	83	10	115	NFQF10...	■	□	□	02728947	□
6,99	6,99 H7/7 K7	6,990/7,005	.2752/ .2758	6,8-6,9	NF10-6.99 H7-EB..	6	83	10	115	NFQF10...	■	□	□	02728948	□
7,00	7 H7	7,000/7,015	.2756/ .2762	6,8-6,9	NF10-7 H7-EB..	6	83	10	115	NFQF10...	■	□	□	02728949	□
7,01	7,01 H7	7,010/7,025	.2760/ .2766	6,8-6,9	NF10-7.01 H7-EB..	6	83	10	115	NFQF10...	■	□	□	02728950	□
7,02	7,02 H7	7,020/7,035	.2764/ .2770	6,9	NF10-7.02 H7-EB..	6	83	10	115	NFQF10...	■	□	□	02728951	□
7,03	7,03 H7/7 E8	7,030/7,045	.2768/ .2774	6,9	NF10-7.03 H7-EB..	6	83	10	115	NFQF10...	■	□	□	02728952	□
7,04	7,04 H7/7 D7	7,040/7,055	.2772/ .2778	6,9	NF10-7.04 H7-EB..	6	83	10	115	NFQF10...	■	□	□	02728953	□
7,05	7,05 H7	7,050/7,065	.2776/ .2781	6,9	NF10-7.05 H7-EB..	6	83	10	115	NFQF10...	■	□	□	02728954	□
7,50	7,5 H7	7,500/7,515	.2953/ .2959	7,3-7,4	NF10-7.5 H7-EB..	6	83	10	115	NFQF10...	■	□	□	02728955	□
7,937	7,937 H7	7,937/7,952	.3125/ .3131	7,8	NF10-7.9375 H7-EB..	6	83	10	115	NFQF10...	■	□	□	02762018	□
7,97	7,97 H7	7,970/7,985	.3138/ .3144	7,8-7,9	NF10-7.97 H7-EB..	6	83	10	115	NFQF10...	■	□	□	02728956	□
7,98	7,98 H7	7,980/7,995	.3142/ .3148	7,8-7,9	NF10-7.98 H7-EB..	6	83	10	115	NFQF10...	■	□	□	02728957	□
7,99	7,99 H7/8 K7	7,990/8,005	.3146/ .3152	7,8-7,9	NF10-7.99 H7-EB..	6	83	10	115	NFQF10...	■	□	□	02728958	□
8,00	8 H7	8,000/8,015	.3150/ .3156	7,8-7,9	NF10-8 H7-EB..	6	83	10	115	NFQF10...	■	□	□	02728959	□
8,01	8,01 H7	8,010/8,025	.3154/ .3159	7,8-7,9	NF10-8.01 H7-EB..	6	83	10	115	NFQF10...	■	□	□	02728960	□
8,02	8,02 H7	8,020/8,035	.3157/ .3163	7,9	NF10-8.02 H7-EB..	6	83	10	115	NFQF10...	■	□	□	02728961	□
8,03	8,03 H7/8 E8	8,030/8,045	.3161/ .3167	7,9	NF10-8.03H7-EB..	6	83	10	115	NFQF10...	■	□	□	02728962	□
8,04	8,04 H7/8 D7	8,040/8,055	.3165/ .3171	7,9	NF10-8.04 H7-EB..	6	83	10	115	NFQF10...	■	□	□	02728963	□
8,05	8,05 H7	8,050/8,065	.3169/ .3175	7,9	NF10-8.05 H7-EB..	6	83	10	115	NFQF10...	■	□	□	02728964	□
8,50	8,5 H7	8,500/8,515	.3346/ .3352	8,3-8,338-8,4	NF10-8.5 H7-EB..	6	93	125	125	NFQF10...	■	□	□	02728965	□
8,97	8,97 H7	8,970/8,985	.3531/ .3537	8,8-8,9	NF10-8.97 H7-EB..	6	93	10	125	NFQF10...	■	□	□	02728966	□
8,98	8,98 H7	8,980/8,995	.3535/ .3541	8,8-8,9	NF10-8.98 H7-EB..	6	93	10	125	NFQF10...	■	□	□	02728967	□
8,99	8,99 H7/9 K7	8,990/9,005	.3539/ .3545	8,8-8,9	NF10-8.99 H7-EB..	6	93	10	125	NFQF10...	■	□	□	02728968	□
9,00	9 H7	9,000/9,015	.3543/ .3549	8,8-8,9	NF10-9 H7-EB..	6	93	10	125	NFQF10...	■	□	□	02728974	□
9,01	9,01 H7	9,010/9,025	.3547/ .3553	8,8-8,9	NF10-9.01 H7-EB..	6	93	10	125	NFQF10...	■	□	□	02728975	□
9,02	9,02 H7	9,020/9,035	.3551/ .3557	8,9	NF10-9.02 H7-EB..	6	93	10	125	NFQF10...	■	□	□	02728976	□
9,03	9,03 H7/9 E8	9,030/9,045	.3555/ .3561	8,9	NF10-9.03 H7-EB..	6	93	10	125	NFQF10...	■	□	□	02728977	□
9,04	9,04 H7/9 D7	9,040/9,055	.3559/ .3565	8,9	NF10-9.04 H7-EB..	6	93	10	125	NFQF10...	■	□	□	02728978	□
9,05	9,05 H7	9,050/9,065	.3563/ .3569	8,9	NF10-9.05 H7-EB..	6	93	10	125	NFQF10...	■	□	□	02728979	□
9,50	9,5 H7	9,500/9,515	.3740/ .3746	9,3-9,4	NF10-9.5 H7-EB..	6	93	10	125	NFQF10...	■	□	□	02728980	□
9,512	9,512 H7	9,512/9,527	.3745/ .3751	9,3-9,4	NF10-9.5123 H7-EB..	6	93	10	125	NFQF10...	■	□	□	02762019	□

■ Stock standard □ Non stock standard. Subject to change refer to current price- and stock-list.

Note: When ordering Nanofix reamers for intermediate diameters, please state diameter and tolerance of hole to be reamed.

Ordering example: NF10-10,187/10,213-EB845, RX2000.

Reamer for blind and through holes \varnothing 9,525-12,05 mm

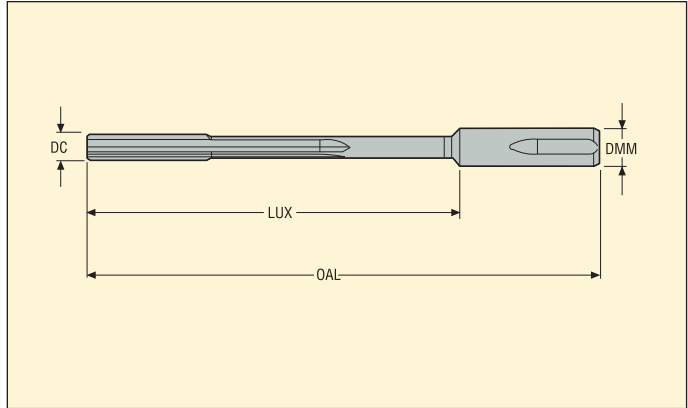

DC	Hole dia ISO (mm)	Hole dia min/max (mm)	Hole dia min/max (inch)	Seco drill size (mm)	Designation	Dimensions in mm				Body size	Geometries			Grades	
						\varnothing	LUX	DMM	OAL		EB45	EB845	EB25	RX2000	H15
9,525	9,525 H7	9,525/9,54	.3750/ .3756	9,8-9,9	NF10-9.525 H7-EB..	6	93	10	125	NFQF10...	■	□	□	02762020	□
9,97	9,97 H7	9,970/9,985	.3925/ .3931	9,8-9,9	NF10-9.97 H7-EB..	6	93	10	125	NFQF10...	■	□	□	02728981	□
9,98	9,98 H7	9,980/9,995	.3929/ .3935	9,8-9,9	NF10-9.98 H7-EB..	6	93	10	125	NFQF10...	■	□	□	02728982	□
9,99	9,99 H7/10 K7	9,990/10,005	.3933/ .3939	9,8-9,9	NF10-9.99 H7-EB..	6	93	10	125	NFQF10...	■	□	□	02728983	□
10,00	10 H7	10,000/10,015	.3937/ .3943	9,8-9,9	NF10-10 H7-EB..	6	93	10	125	NFQF10...	■	□	□	02728986	□
10,01	10,01 H7	10,010/10,028	.3941/ .3948	9,8-9,9	NF10-10.01 H7-EB..	6	93	10	125	NFQF10...	■	□	□	02728987	□
10,02	10,02 H7	10,020/10,038	.3945/ .3952	9,8-9,9	NF10-10.02 H7-EB..	6	93	10	125	NFQF10...	■	□	□	02728988	□
10,03	10,03 H7/10 E8	10,030/10,048	.3949/ .3956	9,9	NF10-10.03 H7-EB..	6	93	10	125	NFQF10...	■	□	□	02728989	□
10,04	10,04 H7/10 D7	10,040/10,058	.3953/ .3960	9,9	NF10-10.04 H7-EB..	6	93	10	125	NFQF10...	■	□	□	02728990	□
10,05	10,05 H7	10,050/10,068	.3957/ .3964	9,9	NF10-10.05 H7-EB..	6	93	10	125	NFQF10...	■	□	□	02728991	□
10,50	10,5 H7	10,500/10,518	.4134/ .4141	10,319-10,4	NF10-10.5 H7-EB..	6	114	10	145	NFQF10...	■	□	□	02728992	□
10,97	10,97 H7	10,970/10,988	.4319/ .4326	10,8	NF10-10.97 H7-EB..	6	114	10	145	NFQF10...	■	□	□	02728994	□
10,98	10,98 H7	10,980/10,998	.4323/ .4330	10,8	NF10-10.98 H7-EB..	6	114	10	145	NFQF10...	■	□	□	02728995	□
10,99	10,99 H7	10,990/11,008	.4327/ .4334	10,8	NF10-10.99 H7-EB..	6	114	10	145	NFQF10...	■	□	□	02728996	□
11,00	11 H7	11,000/11,018	.4331/ .4338	10,8	NF10-11 H7-EB..	6	114	10	145	NFQF10...	■	□	□	02728997	□
11,01	11,01 H7	11,010/11,028	.4335/ .4342	10,8	NF10-11.01 H7-EB..	6	114	10	145	NFQF10...	■	□	□	02728998	□
11,02	11,02 H7/11 F8	11,020/11,038	.4339/ .4346	10,8	NF10-11.02 H7-EB..	6	114	10	145	NFQF10...	■	□	□	02729001	□
11,03	11,03 H7	11,030/11,048	.4343/ .4350	10,8	NF10-11.03 H7-EB..	6	114	10	145	NFQF10...	■	□	□	02729003	□
11,04	11,04 H7/11 E7	11,040/11,058	.4346/ .4354	10,8	NF10-11.04 H7-EB..	6	114	10	145	NFQF10...	■	□	□	02729004	□
11,05	11,05 H7/11 D7	11,050/11,068	.4350/ .4357	10,8	NF10-11.05 H7-EB..	6	114	10	145	NFQF10...	■	□	□	02729005	□
11,112	11,112 H7	11,112/11,130	.4375/ .4382	10,9-11	NF10-11.112 H7-EB..	6	114	10	145	NFQF10...	■	□	□	02762021	□
11,50	11,5 H7	11,500/11,518	.4528/ .4535	11,3	NF10-11.5 H7-EB..	6	114	10	145	NFQF10...	■	□	□	02729007	□
11,97	11,97 H7	11,970/11,988	.4713/ .4720	11,8	NF10-11.97 H7-EB..	6	114	10	145	NFQF10...	■	□	□	02729008	□
11,98	11,98 H7	11,980/11,998	.4717/ .4724	11,8	NF10-11.98 H7-EB..	6	114	10	145	NFQF10...	■	□	□	02729009	□
11,99	11,99 H7	11,990/12,008	.4720/ .4728	11,8	NF10-11.99 H7-EB..	6	114	10	145	NFQF10...	■	□	□	02729010	□
12,00	12 H7	12,000/12,018	.4724/ .4731	11,8	NF10-12 H7-EB..	6	114	10	145	NFQF10...	■	□	□	02729011	□
12,01	12,01 H7	12,010/12,028	.4728/ .4735	11,8	NF10-12.01 H7-EB..	6	114	10	145	NFQF10...	■	□	□	02729012	□
12,02	12,02 H7/12 F8	12,020/12,038	.4732/ .4739	11,8-11,906	NF10-12.02 H7-EB..	6	114	10	145	NFQF10...	■	□	□	02729013	□
12,03	12,03 H7	12,030/12,048	.4736/ .4743	11,8-11,906	NF10-12.03 H7-EB..	6	114	10	145	NFQF10...	■	□	□	02729014	□
12,04	12,04 H7/12 E7	12,040/12,058	.4740/ .4747	11,8-11,906	NF10-12.04 H7-EB..	6	114	10	145	NFQF10...	■	□	□	02729015	□
12,05	12,05 H7/12 D7	12,050/12,068	.4744/ .4751	11,8-11,906	NF10-12.05 H7-EB..	6	114	10	145	NFQF10...	■	□	□	02729016	□

■ Stock standard □ Non stock standard. Subject to change refer to current price- and stock-list.

Note: When ordering Nanofix reamers for intermediate diameters, please state diameter and tolerance of hole to be reamed.

Ordering example: NF10-10,187/10,213-EB845, RX2000.

Intermediate diameter

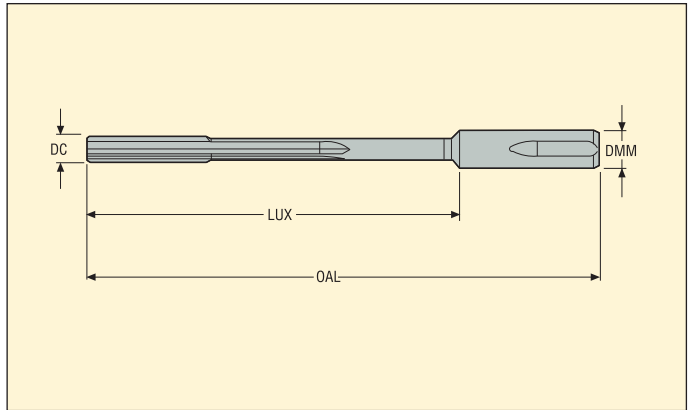

- For cutting data see page(s) 279
- For choice of geometry EB45 or EB845, please see page(s) 241

DC	Designation	Dimensions in mm				Body size	Geometries		Grades						
		OAL	LUX	DMM			EB45	EB845	RX2000	H15	RN2010	RM2020	RM2090	RS2090	
2,970-3,050	NF06-xx-xxx-xxxx	60	40	6	4	NFQF06...	<input type="checkbox"/>	<input type="checkbox"/>	<input type="checkbox"/>	<input type="checkbox"/>	<input type="checkbox"/>	<input type="checkbox"/>	<input type="checkbox"/>	<input type="checkbox"/>	<input type="checkbox"/>
3,051-6,050	NF06-xx-xxx-xxxx	80	60	6	4	NFQF06...	<input type="checkbox"/>	<input type="checkbox"/>	<input type="checkbox"/>	<input type="checkbox"/>	<input type="checkbox"/>	<input type="checkbox"/>	<input type="checkbox"/>	<input type="checkbox"/>	<input type="checkbox"/>
6,051-8,050	NF10-xx-xxx-xxxx	115	83	10	6	NFQF10...	<input type="checkbox"/>	<input type="checkbox"/>	<input type="checkbox"/>	<input type="checkbox"/>	<input type="checkbox"/>	<input type="checkbox"/>	<input type="checkbox"/>	<input type="checkbox"/>	<input type="checkbox"/>
8,051-10,050	NF10-xx-xxx-xxxx	125	93	10	6	NFQF10...	<input type="checkbox"/>	<input type="checkbox"/>	<input type="checkbox"/>	<input type="checkbox"/>	<input type="checkbox"/>	<input type="checkbox"/>	<input type="checkbox"/>	<input type="checkbox"/>	<input type="checkbox"/>
10,051-12,050	NF10-xx-xxx-xxxx	145	114	10	6	NFQF10...	<input type="checkbox"/>	<input type="checkbox"/>	<input type="checkbox"/>	<input type="checkbox"/>	<input type="checkbox"/>	<input type="checkbox"/>	<input type="checkbox"/>	<input type="checkbox"/>	<input type="checkbox"/>

= Non stock standard. Subject to change refer to current price- and stock-list
 Note: When ordering Nanofix reamers for intermediate diameters, please state diameter and tolerance of hole to be reamed.
 Ordering example: NF10-10,187/10,213-EB845, RS2090.

Reamer for blind and through holes \varnothing 2,97-6,00 mm - short version

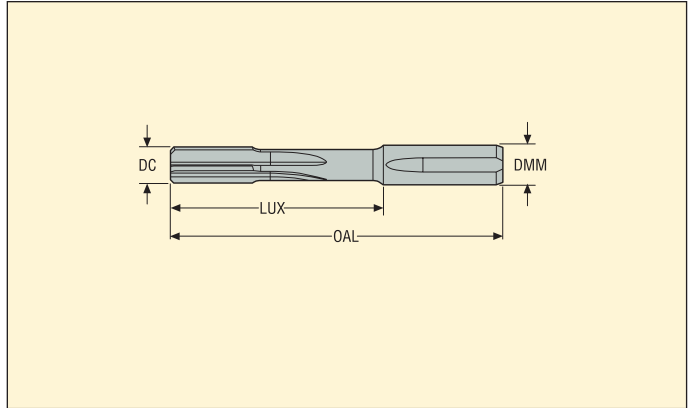
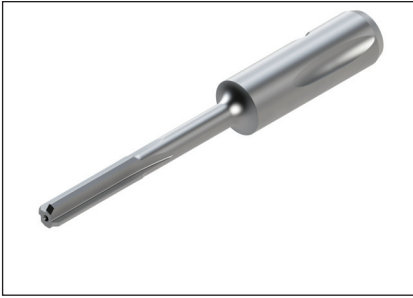

DC	Hole dia ISO (mm)	Hole dia min/max (mm)	Hole dia min/max (inch)	Seco drill size (mm)	Designation	Dimensions in mm					Geometries			Grades	
							LUX	DMM	OAL	Body size	EB45	EB845	EB25	RX2000	H15
2,97	2,97 H7	2,970/2,980	.1169/.1173	2,8-2,9	NS06-2.97 H7-EB...	4	25	6	45	NFQF06...	<input type="checkbox"/>	<input type="checkbox"/>	<input type="checkbox"/>	<input type="checkbox"/>	<input type="checkbox"/>
2,98	2,98 H7	2,980/2,990	.1173/.1177	2,8-2,9	NS06-2.98 H7-EB...	4	25	6	45	NFQF06...	<input type="checkbox"/>	<input type="checkbox"/>	<input type="checkbox"/>	<input type="checkbox"/>	<input type="checkbox"/>
2,99	2,99 H7/3 K7	2,990/3,000	.1177/.1181	2,8-2,9	NS06-2.99 H7-EB...	4	25	6	45	NFQF06...	<input type="checkbox"/>	<input type="checkbox"/>	<input type="checkbox"/>	<input type="checkbox"/>	<input type="checkbox"/>
3,00	3 H7	3,000/3,010	.1181/.1185	2,8-2,9	NS06-3 H7-EB...	4	25	6	45	NFQF06...	<input type="checkbox"/>	<input type="checkbox"/>	<input type="checkbox"/>	<input type="checkbox"/>	<input type="checkbox"/>
3,01	3,01 H7	3,010/3,022	.1185/.1190	2,8-2,9	NS06-3.01 H7-EB...	4	25	6	45	NFQF06...	<input type="checkbox"/>	<input type="checkbox"/>	<input type="checkbox"/>	<input type="checkbox"/>	<input type="checkbox"/>
3,02	3,02 H7/3 D7	3,020/3,032	.1189/.1194	2,9	NS06-3.02 H7-EB...	4	25	6	45	NFQF06...	<input type="checkbox"/>	<input type="checkbox"/>	<input type="checkbox"/>	<input type="checkbox"/>	<input type="checkbox"/>
3,03	3,03 H7	3,030/3,042	.1193/.1198	2,9	NS06-3.03 H7-EB...	4	25	6	45	NFQF06...	<input type="checkbox"/>	<input type="checkbox"/>	<input type="checkbox"/>	<input type="checkbox"/>	<input type="checkbox"/>
3,04	3,04 H7/3D10	3,040/3,052	.1197/.1202	2,9	NS06-3.04 H7-EB...	4	25	6	45	NFQF06...	<input type="checkbox"/>	<input type="checkbox"/>	<input type="checkbox"/>	<input type="checkbox"/>	<input type="checkbox"/>
3,05	3,05 H7	3,050/3,062	.1201/.1206	2,9	NS06-3.05 H7-EB...	4	25	6	45	NFQF06...	<input type="checkbox"/>	<input type="checkbox"/>	<input type="checkbox"/>	<input type="checkbox"/>	<input type="checkbox"/>
3,167	3,167 H7	3,179/3,167	.1252/.1247	3	NS06-3.167 H7-EB...	4	30	6	50	NFQF06...	<input type="checkbox"/>	<input type="checkbox"/>	<input type="checkbox"/>	<input type="checkbox"/>	<input type="checkbox"/>
3,175	3,175 H7	3,175/3,187	.1250/.1255	3	NS06-3.175 H7-EB...	4	30	6	50	NFQF06...	<input type="checkbox"/>	<input type="checkbox"/>	<input type="checkbox"/>	<input type="checkbox"/>	<input type="checkbox"/>
3,49	3,49 H7	3,490/3,502	.1374/.1379	3,3-3,4	NS06-3.49 H7-EB...	4	30	6	50	NFQF06...	<input type="checkbox"/>	<input type="checkbox"/>	<input type="checkbox"/>	<input type="checkbox"/>	<input type="checkbox"/>
3,50	3,5 H7	3,500/3,512	.1378/.1383	3,3-3,4	NS06-3.5 H7-EB...	4	30	6	50	NFQF06...	<input type="checkbox"/>	<input type="checkbox"/>	<input type="checkbox"/>	<input type="checkbox"/>	<input type="checkbox"/>
3,51	3,51 H7	3,510/3,522	.1382/.1387	3,3-3,4	NS06-3.51 H7-EB...	4	30	6	50	NFQF06...	<input type="checkbox"/>	<input type="checkbox"/>	<input type="checkbox"/>	<input type="checkbox"/>	<input type="checkbox"/>
3,52	3,52 H7	3,520/3,532	.1386/.1391	3,3-3,4	NS06-3.52 H7-EB...	4	30	6	50	NFQF06...	<input type="checkbox"/>	<input type="checkbox"/>	<input type="checkbox"/>	<input type="checkbox"/>	<input type="checkbox"/>
3,97	3,97 H7	3,970/3,982	.1563/.1568	3,8-3,9	NS06-3.97 H7-EB...	4	30	6	50	NFQF06...	<input type="checkbox"/>	<input type="checkbox"/>	<input type="checkbox"/>	<input type="checkbox"/>	<input type="checkbox"/>
3,98	3,98 H7/4 P7	3,980/3,992	.1567/.1572	3,8-3,9	NS06-3.98 H7-EB...	4	30	6	50	NFQF06...	<input type="checkbox"/>	<input type="checkbox"/>	<input type="checkbox"/>	<input type="checkbox"/>	<input type="checkbox"/>
3,99	3,99 H7/4 K8	3,990/4,002	.1571/.1576	3,8-3,9	NS06-3.99 H7-EB...	4	30	6	50	NFQF06...	<input type="checkbox"/>	<input type="checkbox"/>	<input type="checkbox"/>	<input type="checkbox"/>	<input type="checkbox"/>
4,00	4 H7	4,000/4,012	.1575/.1580	3,8-3,9	NS06-4 H7-EB...	4	30	6	50	NFQF06...	<input type="checkbox"/>	<input type="checkbox"/>	<input type="checkbox"/>	<input type="checkbox"/>	<input type="checkbox"/>
4,01	4,01 H7/4 F7	4,010/4,022	.1579/.1583	3,8-3,9	NS06-4.01 H7-EB...	4	30	6	50	NFQF06...	<input type="checkbox"/>	<input type="checkbox"/>	<input type="checkbox"/>	<input type="checkbox"/>	<input type="checkbox"/>
4,02	4,02 H7/4 E7	4,020/4,032	.1583/.1587	3,9	NS06-4.02 H7-EB...	4	30	6	50	NFQF06...	<input type="checkbox"/>	<input type="checkbox"/>	<input type="checkbox"/>	<input type="checkbox"/>	<input type="checkbox"/>
4,03	4,03 H7/4 D7	4,030/4,042	.1587/.1591	3,9	NS06-4.03 H7-EB...	4	30	6	50	NFQF06...	<input type="checkbox"/>	<input type="checkbox"/>	<input type="checkbox"/>	<input type="checkbox"/>	<input type="checkbox"/>
4,04	4,04 H7	4,040/4,052	.1591/.1595	3,9	NS06-4.04 H7-EB...	4	30	6	50	NFQF06...	<input type="checkbox"/>	<input type="checkbox"/>	<input type="checkbox"/>	<input type="checkbox"/>	<input type="checkbox"/>
4,05	4,05 H7	4,050/4,062	.1594/.1599	3,9	NS06-4.05 H7-EB...	4	30	6	50	NFQF06...	<input type="checkbox"/>	<input type="checkbox"/>	<input type="checkbox"/>	<input type="checkbox"/>	<input type="checkbox"/>
4,50	4,5 H7	4,500/4,512	.1772/.1776	4,3-4,4	NS06-4.5 H7-EB...	4	30	6	50	NFQF06...	<input type="checkbox"/>	<input type="checkbox"/>	<input type="checkbox"/>	<input type="checkbox"/>	<input type="checkbox"/>
4,75	4,75 H7	4,750/4,762	.1870/.1875	4,5	NS06-4.750 H7-EB...	4	30	6	50	NFQF06...	<input type="checkbox"/>	<input type="checkbox"/>	<input type="checkbox"/>	<input type="checkbox"/>	<input type="checkbox"/>
4,762	4,762 H7	4,762/4,774	.1875/.1880	4,5	NS06-4.762 H7-EB...	4	30	6	50	NFQF06...	<input type="checkbox"/>	<input type="checkbox"/>	<input type="checkbox"/>	<input type="checkbox"/>	<input type="checkbox"/>
4,97	4,97 H7	4,970/4,982	.1957/.1961	4,8-4,9	NS06-4.97 H7-EB...	4	30	6	50	NFQF06...	<input type="checkbox"/>	<input type="checkbox"/>	<input type="checkbox"/>	<input type="checkbox"/>	<input type="checkbox"/>
4,98	4,98 H7/5 P7	4,980/4,992	.1961/.1965	4,8-4,9	NS06-4.98 H7-EB...	4	30	6	50	NFQF06...	<input type="checkbox"/>	<input type="checkbox"/>	<input type="checkbox"/>	<input type="checkbox"/>	<input type="checkbox"/>
4,99	4,99 H7/5 K8	4,990/5,002	.1965/.1969	4,8-4,9	NS06-4.99 H7-EB...	4	30	6	50	NFQF06...	<input type="checkbox"/>	<input type="checkbox"/>	<input type="checkbox"/>	<input type="checkbox"/>	<input type="checkbox"/>
5,00	5 H7	5,000/5,012	.1969/.1973	4,8-4,9	NS06-5 H7-EB...	4	30	6	50	NFQF06...	<input type="checkbox"/>	<input type="checkbox"/>	<input type="checkbox"/>	<input type="checkbox"/>	<input type="checkbox"/>
5,01	5,01 H7/5 F7	5,010/5,022	.1972/.1977	4,8-4,9	NS06-5.01 H7-EB...	4	30	6	50	NFQF06...	<input type="checkbox"/>	<input type="checkbox"/>	<input type="checkbox"/>	<input type="checkbox"/>	<input type="checkbox"/>
5,02	5,02 H7/5 E7	5,020/5,032	.1976/.1981	4,9	NS06-5.02 H7-EB...	4	30	6	50	NFQF06...	<input type="checkbox"/>	<input type="checkbox"/>	<input type="checkbox"/>	<input type="checkbox"/>	<input type="checkbox"/>
5,03	5,03 H7/5 D7	5,030/5,042	.1980/.1985	4,9	NS06-5.03 H7-EB...	4	30	6	50	NFQF06...	<input type="checkbox"/>	<input type="checkbox"/>	<input type="checkbox"/>	<input type="checkbox"/>	<input type="checkbox"/>
5,04	5,04 H7	5,040/5,052	.1984/.1989	4,9	NS06-5.04 H7-EB...	4	30	6	50	NFQF06...	<input type="checkbox"/>	<input type="checkbox"/>	<input type="checkbox"/>	<input type="checkbox"/>	<input type="checkbox"/>
5,05	5,05 H7	5,050/5,062	.1988/.1993	4,9	NS06-5.05 H7-EB...	4	30	6	50	NFQF06...	<input type="checkbox"/>	<input type="checkbox"/>	<input type="checkbox"/>	<input type="checkbox"/>	<input type="checkbox"/>
5,50	5,5 H7	5,500/5,512	.2165/.2170	5,3-5,4	NS06-5.5 H7-EB...	4	30	6	50	NFQF06...	<input type="checkbox"/>	<input type="checkbox"/>	<input type="checkbox"/>	<input type="checkbox"/>	<input type="checkbox"/>
5,97	5,97 H7	5,970/5,982	.2350/.2355	5,8-5,9	NS06-5.97 H7-EB...	4	31	6	50	NFQF06...	<input type="checkbox"/>	<input type="checkbox"/>	<input type="checkbox"/>	<input type="checkbox"/>	<input type="checkbox"/>
5,98	5,98 H7/6 P7	5,980/5,992	.2354/.2359	5,8-5,9	NS06-5.98 H7-EB...	4	31	6	50	NFQF06...	<input type="checkbox"/>	<input type="checkbox"/>	<input type="checkbox"/>	<input type="checkbox"/>	<input type="checkbox"/>
5,99	5,99 H7/6 K8	5,990/6,002	.2358/.2363	5,8-5,9	NS06-5.99 H7-EB...	4	31	6	50	NFQF06...	<input type="checkbox"/>	<input type="checkbox"/>	<input type="checkbox"/>	<input type="checkbox"/>	<input type="checkbox"/>
6,00	6 H7	6,000/6,012	.2362/.2367	5,8-5,9	NS06-6 H7-EB...	4	31	6	31	NFQF06...	<input type="checkbox"/>	<input type="checkbox"/>	<input type="checkbox"/>	<input type="checkbox"/>	<input type="checkbox"/>

■ Stock standard □ Non stock standard. Subject to change refer to current price- and stock-list.

Note: When ordering Nanofix reamers for intermediate diameters, please state diameter and tolerance of hole to be reamed.

Ordering example: NS10-10,187/10,213-EB845, RX2000.

Reamer for blind and through holes \varnothing 6,01-9,512 mm - short version

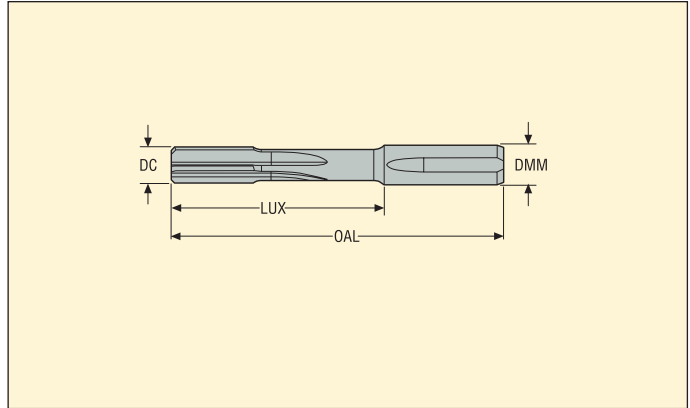
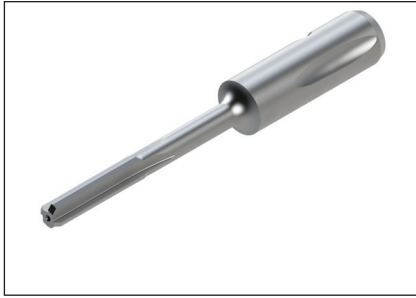

DC	Hole dia ISO (mm)	Hole dia min/max (mm)	Hole dia min/max (inch)	Seco drill size (mm)	Designation	Dimensions in mm					Geometries			Grades	
							LUX	DMM	OAL	Body size	EB45	EB45	EB25	RX2000	H15
6,01	6,01 H7/6 F7	6,010/6,025	.2366/ .2372	5,8-5,9	NS06-6,01 H7-EB...	4	31	6	50	NFQF06...	<input type="checkbox"/>	<input type="checkbox"/>	<input type="checkbox"/>	<input type="checkbox"/>	<input type="checkbox"/>
6,02	6,02 H7/6 E7	6,020/6,035	.2370/ .2376	5,9	NS06-6,02 H7-EB...	4	31	6	50	NFQF06...	<input type="checkbox"/>	<input type="checkbox"/>	<input type="checkbox"/>	<input type="checkbox"/>	<input type="checkbox"/>
6,03	6,03 H7/6 D7	6,030/6,045	.2374/ .2380	5,9	NS06-6,03 H7-EB...	4	31	6	50	NFQF06...	<input type="checkbox"/>	<input type="checkbox"/>	<input type="checkbox"/>	<input type="checkbox"/>	<input type="checkbox"/>
6,04	6,04 H7	6,040/6,055	.2378/ .2384	5,9	NS06-6,04 H7-EB...	4	31	6	50	NFQF06...	<input type="checkbox"/>	<input type="checkbox"/>	<input type="checkbox"/>	<input type="checkbox"/>	<input type="checkbox"/>
6,05	6,05 H7	6,050/6,065	.2382/ .2388	5,9	NS06-6,05 H7-EB...	4	31	6	50	NFQF06...	<input type="checkbox"/>	<input type="checkbox"/>	<input type="checkbox"/>	<input type="checkbox"/>	<input type="checkbox"/>
6,334	6,334 H7	6,334/6,349	.2494/ .2500	6,1-6,2	NS10-6,334 H7-EB...	6	46	10	78	NFQF10...	<input type="checkbox"/>	<input type="checkbox"/>	<input type="checkbox"/>	<input type="checkbox"/>	<input type="checkbox"/>
6,35	6,35 H7	6,35/6,365	.2500/ .2506	6,2	NS10-6,350 H7-EB...	6	46	10	78	NFQF10...	<input type="checkbox"/>	<input type="checkbox"/>	<input type="checkbox"/>	<input type="checkbox"/>	<input type="checkbox"/>
6,375	6,375 H7	6,375/6,39	.2510/ .2516	6,2	NS10-6,375 H7-EB...	6	46	10	78	NFQF10...	<input type="checkbox"/>	<input type="checkbox"/>	<input type="checkbox"/>	<input type="checkbox"/>	<input type="checkbox"/>
6,50	6,5 H7	6,500/6,515	.2559/ .2565	6,3-6,35-6,4	NS10-6,5 H7-EB...	6	46	10	78	NFQF10...	<input type="checkbox"/>	<input type="checkbox"/>	<input type="checkbox"/>	<input type="checkbox"/>	<input type="checkbox"/>
6,97	6,97 H7	6,970/6,985	.2744/ .2750	6,8-6,9	NS10-6,97 H7-EB...	6	46	10	78	NFQF10...	<input type="checkbox"/>	<input type="checkbox"/>	<input type="checkbox"/>	<input type="checkbox"/>	<input type="checkbox"/>
6,98	6,98 H7	6,980/6,995	.2748/ .2754	6,8-6,9	NS10-6,98 H7-EB...	6	46	10	78	NFQF10...	<input type="checkbox"/>	<input type="checkbox"/>	<input type="checkbox"/>	<input type="checkbox"/>	<input type="checkbox"/>
6,99	6,99 H7/7 K7	6,990/7,005	.2752/ .2758	6,8-6,9	NS10-6,99 H7-EB...	6	46	10	78	NFQF10...	<input type="checkbox"/>	<input type="checkbox"/>	<input type="checkbox"/>	<input type="checkbox"/>	<input type="checkbox"/>
7,00	7 H7	7,000/7,015	.2756/ .2762	6,8-6,9	NS10-7 H7-EB...	6	46	10	78	NFQF10...	<input type="checkbox"/>	<input type="checkbox"/>	<input type="checkbox"/>	<input type="checkbox"/>	<input type="checkbox"/>
7,01	7,01 H7	7,010/7,025	.2760/ .2766	6,8-6,9	NS10-7,01 H7-EB...	6	46	10	78	NFQF10...	<input type="checkbox"/>	<input type="checkbox"/>	<input type="checkbox"/>	<input type="checkbox"/>	<input type="checkbox"/>
7,02	7,02 H7	7,020/7,035	.2764/ .2770	6,9	NS10-7,02 H7-EB...	6	46	10	78	NFQF10...	<input type="checkbox"/>	<input type="checkbox"/>	<input type="checkbox"/>	<input type="checkbox"/>	<input type="checkbox"/>
7,03	7,03 H7/7 E8	7,030/7,045	.2768/ .2774	6,9	NS10-7,03 H7-EB...	6	46	10	78	NFQF10...	<input type="checkbox"/>	<input type="checkbox"/>	<input type="checkbox"/>	<input type="checkbox"/>	<input type="checkbox"/>
7,04	7,04 H7/7 D7	7,040/7,055	.2772/ .2778	6,9	NS10-7,04 H7-EB...	6	46	10	78	NFQF10...	<input type="checkbox"/>	<input type="checkbox"/>	<input type="checkbox"/>	<input type="checkbox"/>	<input type="checkbox"/>
7,05	7,05 H7	7,050/7,065	.2776/ .2781	6,9	NS10-7,05 H7-EB...	6	46	10	78	NFQF10...	<input type="checkbox"/>	<input type="checkbox"/>	<input type="checkbox"/>	<input type="checkbox"/>	<input type="checkbox"/>
7,50	7,5 H7	7,500/7,515	.2953/ .2959	7,3-7,4	NS10-7,5 H7-EB...	6	46	10	78	NFQF10...	<input type="checkbox"/>	<input type="checkbox"/>	<input type="checkbox"/>	<input type="checkbox"/>	<input type="checkbox"/>
7,937	7,937 H7	7,937/7,952	.3125/ .3131	7,8	NS10-7,9375 H7-EB...	6	46	10	78	NFQF10...	<input type="checkbox"/>	<input type="checkbox"/>	<input type="checkbox"/>	<input type="checkbox"/>	<input type="checkbox"/>
7,97	7,97 H7	7,970/7,985	.3138/ .3144	7,8-7,9	NS10-7,97 H7-EB...	6	46	10	78	NFQF10...	<input type="checkbox"/>	<input type="checkbox"/>	<input type="checkbox"/>	<input type="checkbox"/>	<input type="checkbox"/>
7,98	7,98 H7	7,980/7,995	.3142/ .3148	7,8-7,9	NS10-7,98 H7-EB...	6	46	10	78	NFQF10...	<input type="checkbox"/>	<input type="checkbox"/>	<input type="checkbox"/>	<input type="checkbox"/>	<input type="checkbox"/>
7,99	7,99 H7/8 K7	7,990/8,005	.3146/ .3152	7,8-7,9	NS10-7,99 H7-EB...	6	46	10	78	NFQF10...	<input type="checkbox"/>	<input type="checkbox"/>	<input type="checkbox"/>	<input type="checkbox"/>	<input type="checkbox"/>
8,00	8 H7	8,000/8,015	.3150/ .3156	7,8-7,9	NS10-8 H7-EB...	6	46	10	78	NFQF10...	<input type="checkbox"/>	<input type="checkbox"/>	<input type="checkbox"/>	<input type="checkbox"/>	<input type="checkbox"/>
8,01	8,01 H7	8,010/8,025	.3154/ .3159	7,8-7,9	NS10-8,01 H7-EB...	6	46	10	78	NFQF10...	<input type="checkbox"/>	<input type="checkbox"/>	<input type="checkbox"/>	<input type="checkbox"/>	<input type="checkbox"/>
8,02	8,02 H7	8,020/8,035	.3157/ .3163	7,9	NS10-8,02 H7-EB...	6	46	10	78	NFQF10...	<input type="checkbox"/>	<input type="checkbox"/>	<input type="checkbox"/>	<input type="checkbox"/>	<input type="checkbox"/>
8,03	8,03 H7/8 E8	8,030/8,045	.3161/ .3167	7,9	NS10-8,03 H7-EB...	6	46	10	78	NFQF10...	<input type="checkbox"/>	<input type="checkbox"/>	<input type="checkbox"/>	<input type="checkbox"/>	<input type="checkbox"/>
8,04	8,04 H7/8 D7	8,040/8,055	.3165/ .3171	7,9	NS10-8,04 H7-EB...	6	46	10	78	NFQF10...	<input type="checkbox"/>	<input type="checkbox"/>	<input type="checkbox"/>	<input type="checkbox"/>	<input type="checkbox"/>
8,05	8,05 H7	8,050/8,065	.3169/ .3175	7,9	NS10-8,05 H7-EB...	6	46	10	78	NFQF10...	<input type="checkbox"/>	<input type="checkbox"/>	<input type="checkbox"/>	<input type="checkbox"/>	<input type="checkbox"/>
8,50	8,5 H7	8,500/8,515	.3346/ .3352	8,3-8,338-8,4	NS10-8,5 H7-EB...	6	46	10	78	NFQF10...	<input type="checkbox"/>	<input type="checkbox"/>	<input type="checkbox"/>	<input type="checkbox"/>	<input type="checkbox"/>
8,97	8,97 H7	8,970/8,985	.3531/ .3537	8,8-8,9	NS10-8,97 H7-EB...	6	46	10	78	NFQF10...	<input type="checkbox"/>	<input type="checkbox"/>	<input type="checkbox"/>	<input type="checkbox"/>	<input type="checkbox"/>
8,98	8,98 H7	8,980/8,995	.3535/ .3541	8,8-8,9	NS10-8,98 H7-EB...	6	46	10	78	NFQF10...	<input type="checkbox"/>	<input type="checkbox"/>	<input type="checkbox"/>	<input type="checkbox"/>	<input type="checkbox"/>
8,99	8,99 H7/9 K7	8,990/9,005	.3539/ .3545	8,8-8,9	NS10-8,99 H7-EB...	6	46	10	78	NFQF10...	<input type="checkbox"/>	<input type="checkbox"/>	<input type="checkbox"/>	<input type="checkbox"/>	<input type="checkbox"/>
9,00	9 H7	9,000/9,015	.3543/ .3549	8,8-8,9	NS10-9 H7-EB...	6	46	10	78	NFQF10...	<input type="checkbox"/>	<input type="checkbox"/>	<input type="checkbox"/>	<input type="checkbox"/>	<input type="checkbox"/>
9,01	9,01 H7	9,010/9,025	.3547/ .3553	8,8-8,9	NS10-9,01 H7-EB...	6	46	10	78	NFQF10...	<input type="checkbox"/>	<input type="checkbox"/>	<input type="checkbox"/>	<input type="checkbox"/>	<input type="checkbox"/>
9,02	9,02 H7	9,020/9,035	.3551/ .3557	8,9	NS10-9,02 H7-EB...	6	46	10	78	NFQF10...	<input type="checkbox"/>	<input type="checkbox"/>	<input type="checkbox"/>	<input type="checkbox"/>	<input type="checkbox"/>
9,03	9,03 H7/9 E8	9,030/9,045	.3555/ .3561	8,9	NS10-9,03 H7-EB...	6	46	10	78	NFQF10...	<input type="checkbox"/>	<input type="checkbox"/>	<input type="checkbox"/>	<input type="checkbox"/>	<input type="checkbox"/>
9,04	9,04 H7/9 D7	9,040/9,055	.3559/ .3565	8,9	NS10-9,04 H7-EB...	6	46	10	78	NFQF10...	<input type="checkbox"/>	<input type="checkbox"/>	<input type="checkbox"/>	<input type="checkbox"/>	<input type="checkbox"/>
9,05	9,05 H7	9,050/9,065	.3563/ .3569	8,9	NS10-9,05 H7-EB...	6	46	10	78	NFQF10...	<input type="checkbox"/>	<input type="checkbox"/>	<input type="checkbox"/>	<input type="checkbox"/>	<input type="checkbox"/>
9,50	9,5 H7	9,500/9,515	.3740/ .3746	9,3-9,4	NS10-9,5 H7-EB...	6	46	10	78	NFQF10...	<input type="checkbox"/>	<input type="checkbox"/>	<input type="checkbox"/>	<input type="checkbox"/>	<input type="checkbox"/>
9,512	9,512 H7	9,512/9,527	.3745/ .3751	9,3-9,4	NS10-9,5123 H7-EB...	6	46	10	78	NFQF10...	<input type="checkbox"/>	<input type="checkbox"/>	<input type="checkbox"/>	<input type="checkbox"/>	<input type="checkbox"/>

■ Stock standard □ Non stock standard. Subject to change refer to current price- and stock-list.

Note: When ordering Nanofix reamers for intermediate diameters, please state diameter and tolerance of hole to be reamed.

Ordering example: NS10-10,187/10,213-EB45, RX2000.

Reamer for blind and through holes \varnothing 9,525-12,05 mm - short version

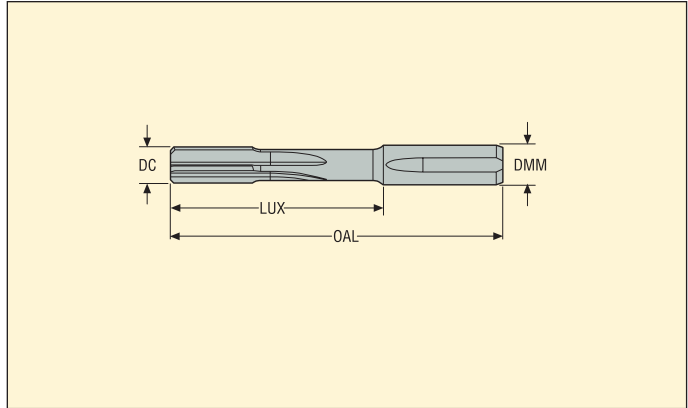
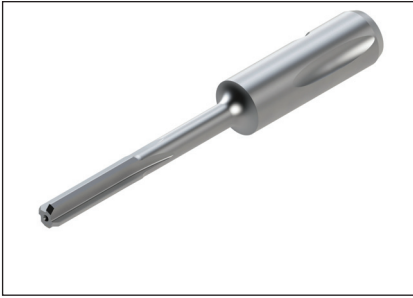

DC	Hole dia ISO (mm)	Hole dia min/max (mm)	Hole dia min/max (inch)	Seco drill size (mm)	Designation	Dimensions in mm					Geometries			Grades	
							LUX	DMM	OAL	Body size	EB45	EB845	EB25	RX2000	H15
9,525	9,525 H7	9,525/9,54	.3750/ .3756	9,3-9,4	NS10-9.5250 H7-EB...	6	46	10	78	NFQF10...	<input type="checkbox"/>	<input type="checkbox"/>	<input type="checkbox"/>	<input type="checkbox"/>	<input type="checkbox"/>
9,97	9,97 H7	9,970/9,985	.3925/ .3931	9,8-9,9	NS10-9.97 H7-EB...	6	46	10	78	NFQF10...	<input type="checkbox"/>	<input type="checkbox"/>	<input type="checkbox"/>	<input type="checkbox"/>	<input type="checkbox"/>
9,98	9,98 H7	9,980/9,995	.3929/ .3935	9,8-9,9	NS10-9.98 H7-EB...	6	46	10	78	NFQF10...	<input type="checkbox"/>	<input type="checkbox"/>	<input type="checkbox"/>	<input type="checkbox"/>	<input type="checkbox"/>
9,99	9,99 H7/10 K7	9,990/10,005	.3933/ .3939	9,8-9,9	NS10-9.99 H7-EB...	6	46	10	78	NFQF10...	<input type="checkbox"/>	<input type="checkbox"/>	<input type="checkbox"/>	<input type="checkbox"/>	<input type="checkbox"/>
10,00	10 H7	10,000/10,015	.3937/ .3943	9,8-9,9	NS10-10 H7-EB...	6	46	10	78	NFQF10...	<input type="checkbox"/>	<input type="checkbox"/>	<input type="checkbox"/>	<input type="checkbox"/>	<input type="checkbox"/>
10,01	10,01 H7	10,010/10,028	.3941/ .3948	9,8-9,9	NS10-10.01 H7-EB...	6	46	10	78	NFQF10...	<input type="checkbox"/>	<input type="checkbox"/>	<input type="checkbox"/>	<input type="checkbox"/>	<input type="checkbox"/>
10,02	10,02 H7	10,020/10,038	.3945/ .3952	9,8-9,9	NS10-10.02 H7-EB...	6	46	10	78	NFQF10...	<input type="checkbox"/>	<input type="checkbox"/>	<input type="checkbox"/>	<input type="checkbox"/>	<input type="checkbox"/>
10,03	10,03 H7/10 E8	10,030/10,048	.3949/ .3956	9,9	NS10-10.03 H7-EB...	6	46	10	78	NFQF10...	<input type="checkbox"/>	<input type="checkbox"/>	<input type="checkbox"/>	<input type="checkbox"/>	<input type="checkbox"/>
10,04	10,04 H7/10 D7	10,040/10,058	.3953/ .3960	9,9	NS10-10.04 H7-EB...	6	46	10	78	NFQF10...	<input type="checkbox"/>	<input type="checkbox"/>	<input type="checkbox"/>	<input type="checkbox"/>	<input type="checkbox"/>
10,05	10,05 H7	10,050/10,068	.3957/ .3964	9,9	NS10-10.05 H7-EB...	6	46	10	78	NFQF10...	<input type="checkbox"/>	<input type="checkbox"/>	<input type="checkbox"/>	<input type="checkbox"/>	<input type="checkbox"/>
10,50	10,5 H7	10,500/10,518	.4134/ .4141	10,319-10,4	NS10-10.5 H7-EB...	6	57	10	88	NFQF10...	<input type="checkbox"/>	<input type="checkbox"/>	<input type="checkbox"/>	<input type="checkbox"/>	<input type="checkbox"/>
10,97	10,97 H7	10,970/10,988	.4319/ .4326	10,8	NS10-10.97 H7-EB...	6	57	10	88	NFQF10...	<input type="checkbox"/>	<input type="checkbox"/>	<input type="checkbox"/>	<input type="checkbox"/>	<input type="checkbox"/>
10,98	10,98 H7	10,980/10,998	.4323/ .4330	10,8	NS10-10.98 H7-EB...	6	57	10	88	NFQF10...	<input type="checkbox"/>	<input type="checkbox"/>	<input type="checkbox"/>	<input type="checkbox"/>	<input type="checkbox"/>
10,99	10,99 H7	10,990/11,008	.4327/ .4334	10,8	NS10-10.99 H7-EB...	6	57	10	88	NFQF10...	<input type="checkbox"/>	<input type="checkbox"/>	<input type="checkbox"/>	<input type="checkbox"/>	<input type="checkbox"/>
11,00	11 H7	11,000/11,018	.4331/ .4338	10,8	NS10-11 H7-EB...	6	57	10	88	NFQF10...	<input type="checkbox"/>	<input type="checkbox"/>	<input type="checkbox"/>	<input type="checkbox"/>	<input type="checkbox"/>
11,01	11,01 H7	11,010/11,028	.4335/ .4342	10,8	NS10-11.01 H7-EB...	6	57	10	88	NFQF10...	<input type="checkbox"/>	<input type="checkbox"/>	<input type="checkbox"/>	<input type="checkbox"/>	<input type="checkbox"/>
11,02	11,02 H7/11 F8	11,020/11,038	.4339/ .4346	10,8	NS10-11.02 H7-EB...	6	57	10	88	NFQF10...	<input type="checkbox"/>	<input type="checkbox"/>	<input type="checkbox"/>	<input type="checkbox"/>	<input type="checkbox"/>
11,03	11,03 H7	11,030/11,048	.4343/ .4350	10,8	NS10-11.03 H7-EB...	6	57	10	88	NFQF10...	<input type="checkbox"/>	<input type="checkbox"/>	<input type="checkbox"/>	<input type="checkbox"/>	<input type="checkbox"/>
11,04	11,04 H7/11 E7	11,040/11,058	.4346/ .4354	10,8	NS10-11.04 H7-EB...	6	57	10	88	NFQF10...	<input type="checkbox"/>	<input type="checkbox"/>	<input type="checkbox"/>	<input type="checkbox"/>	<input type="checkbox"/>
11,05	11,05 H7/11 D7	11,050/11,068	.4350/ .4357	10,8	NS10-11.05 H7-EB...	6	57	10	88	NFQF10...	<input type="checkbox"/>	<input type="checkbox"/>	<input type="checkbox"/>	<input type="checkbox"/>	<input type="checkbox"/>
11,112	11,112 H7	11,112/11,130	.4375/ .4382	10,9-11	NS10-11.112 H7-EB...	6	57	10	88	NFQF10...	<input type="checkbox"/>	<input type="checkbox"/>	<input type="checkbox"/>	<input type="checkbox"/>	<input type="checkbox"/>
11,50	11,5 H7	11,500/11,518	.4528/ .4535	11,3	NS10-11.5 H7-EB...	6	57	10	88	NFQF10...	<input type="checkbox"/>	<input type="checkbox"/>	<input type="checkbox"/>	<input type="checkbox"/>	<input type="checkbox"/>
11,97	11,97 H7	11,970/11,988	.4713/ .4720	11,8	NS10-11.97 H7-EB...	6	57	10	88	NFQF10...	<input type="checkbox"/>	<input type="checkbox"/>	<input type="checkbox"/>	<input type="checkbox"/>	<input type="checkbox"/>
11,98	11,98 H7	11,980/11,998	.4717/ .4724	11,8	NS10-11.98 H7-EB...	6	57	10	88	NFQF10...	<input type="checkbox"/>	<input type="checkbox"/>	<input type="checkbox"/>	<input type="checkbox"/>	<input type="checkbox"/>
11,99	11,99 H7	11,990/12,008	.4720/ .4728	11,8	NS10-11.99 H7-EB...	6	57	10	88	NFQF10...	<input type="checkbox"/>	<input type="checkbox"/>	<input type="checkbox"/>	<input type="checkbox"/>	<input type="checkbox"/>
12,00	12 H7	12,000/12,018	.4724/ .4731	11,8	NS10-12 H7-EB...	6	57	10	88	NFQF10...	<input type="checkbox"/>	<input type="checkbox"/>	<input type="checkbox"/>	<input type="checkbox"/>	<input type="checkbox"/>
12,01	12,01 H7	12,010/12,028	.4728/ .4735	11,8	NS10-12.01 H7-EB...	6	57	10	88	NFQF10...	<input type="checkbox"/>	<input type="checkbox"/>	<input type="checkbox"/>	<input type="checkbox"/>	<input type="checkbox"/>
12,02	12,02 H7/12 F8	12,020/12,038	.4732/ .4739	11,8-11,906	NS10-12.02 H7-EB...	6	57	10	88	NFQF10...	<input type="checkbox"/>	<input type="checkbox"/>	<input type="checkbox"/>	<input type="checkbox"/>	<input type="checkbox"/>
12,03	12,03 H7	12,030/12,048	.4736/ .4743	11,8-11,906	NS10-12.03 H7-EB...	6	57	10	88	NFQF10...	<input type="checkbox"/>	<input type="checkbox"/>	<input type="checkbox"/>	<input type="checkbox"/>	<input type="checkbox"/>
12,04	12,04 H7/12 E7	12,040/12,058	.4740/ .4747	11,8-11,906	NS10-12.04 H7-EB...	6	57	10	88	NFQF10...	<input type="checkbox"/>	<input type="checkbox"/>	<input type="checkbox"/>	<input type="checkbox"/>	<input type="checkbox"/>
12,05	12,05 H7/12 D7	12,050/12,068	.4744/ .4751	11,8-11,906	NS10-12.05 H7-EB...	6	57	10	88	NFQF10...	<input type="checkbox"/>	<input type="checkbox"/>	<input type="checkbox"/>	<input type="checkbox"/>	<input type="checkbox"/>

■ Stock standard □ Non stock standard. Subject to change refer to current price- and stock-list.

Note: When ordering Nanofix reamers for intermediate diameters, please state diameter and tolerance of hole to be reamed.

Ordering example: NS10-10,187/10,213-EB845, RX2000.

Intermediate diameter

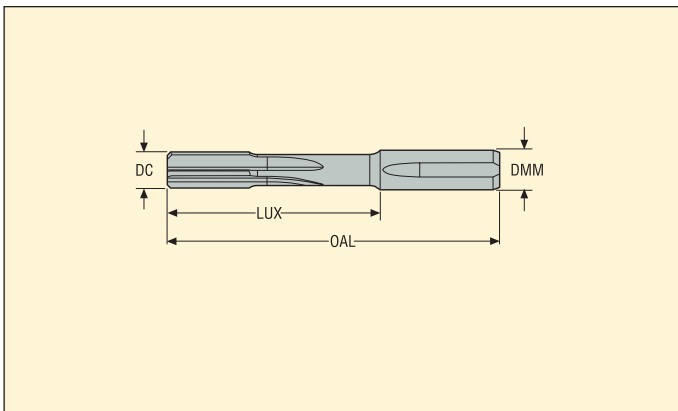

- For cutting data see page(s) 279
- For choice of geometry EB45 or EB845, please see page(s) 266

DC	Designation	Dimensions in mm			⊘	Body size	Geometries		Grades						
		OAL	LUX	DMM			EB45	EB845	RX2000	H15	RN2010	RM2020	RM2090	RS2090	
2,970-3,050	NS06-xx-xxx-xxxx	45	25	6	4	NFQF06...	<input type="checkbox"/>	<input type="checkbox"/>	<input type="checkbox"/>	<input type="checkbox"/>	<input type="checkbox"/>	<input type="checkbox"/>	<input type="checkbox"/>	<input type="checkbox"/>	<input type="checkbox"/>
3,051-6,050	NS06-xx-xxx-xxxx	50	30	6	4	NFQF06...	<input type="checkbox"/>	<input type="checkbox"/>	<input type="checkbox"/>	<input type="checkbox"/>	<input type="checkbox"/>	<input type="checkbox"/>	<input type="checkbox"/>	<input type="checkbox"/>	<input type="checkbox"/>
6,051-10,050	NS10-xx-xxx-xxxx	78	46	10	6	NFQF10...	<input type="checkbox"/>	<input type="checkbox"/>	<input type="checkbox"/>	<input type="checkbox"/>	<input type="checkbox"/>	<input type="checkbox"/>	<input type="checkbox"/>	<input type="checkbox"/>	<input type="checkbox"/>
10,051-12,050	NS10-xx-xxx-xxxx	88	57	10	6	NFQF10...	<input type="checkbox"/>	<input type="checkbox"/>	<input type="checkbox"/>	<input type="checkbox"/>	<input type="checkbox"/>	<input type="checkbox"/>	<input type="checkbox"/>	<input type="checkbox"/>	<input type="checkbox"/>

= Non stock standard. Subject to change refer to current price- and stock-list
 Note: When ordering Nanofix reamers for intermediate diameters, please state diameter and tolerance of hole to be reamed.
 Ordering example: NS10-10,187/10,213-EB845, RS2090.

Nanofix tool holder – metric

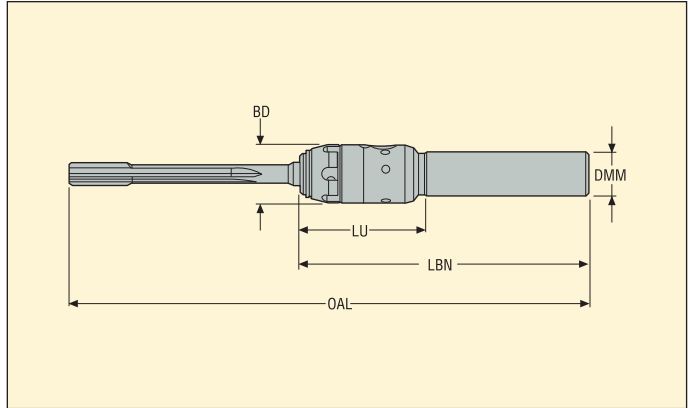

Ordering and Product No.	Designation	Dimensions in mm				
		DC	DMM	BD	LU	LBN
02729036	NFQF06-03700-10N1	2,97-6,05	10	16	37	80
02729037	NFQF06-03300-12N1	2,97-6,05	12	16	35	80
02729041	NFQF06-03000-16N1	2,97-6,05	16	16	30	80
02729044	NFQF10-05200-12N1	6,051-12,05	12	23	52	100
02729045	NFQF10-04900-16N1	6,051-12,05	16	23	49	100
02729046	NFQF10-04700-20N1	6,051-12,05	20	23	47	100

	Standard length	Short length
DC	OAL	OAL
2,970-3,050	124,5	109,5
3,051-6,050	144,5	113,5
6,051-8,050	189,5	152,5
8,051-10,050	199,5	152,5
10,051-12,050	219,5	162,5

Spare Parts

	Spare Clamping Kit	Key
2,97-6,050	NF06-CLKI	CLC06KEY
6,051-12,050	NF10-CLKI	CLC10KEY

Spare clamping kit for Nanofix holders includes:

- 1 clamping nut
- 1 axial stop spring ring
- 3 clamping balls (dia 3,5 mm for size NF06 & dia 5 mm for size NF10)
- 1 fool-proof ball (dia 3 mm for size NF06 & dia 4 mm for size NF10)
- 1 o-ring

Note: fool-proof ball not shown on above view.

Cutting data – NF/NS...-EB845

SMG		a _p (°)		f		v _c		
		z=4	z=6	z=4	z=6	H15	CP20	RX2000
P3	NF/NS-EB845	0,10-0,15	0,1-0,20	0,10-0,30	0,20-0,60	-	60 (30-100)	80 (30-150)
P4	NF/NS-EB845	0,10-0,15	0,1-0,20	0,10-0,20	0,20-0,50	-	50 (30-80)	60 (30-120)
P5	NF/NS-EB845	0,10-0,15	0,1-0,20	0,10-0,20	0,20-0,50	20 (10-25)	50 (30-80)	60 (30-120)
P6	NF/NS-EB845	0,10-0,15	0,1-0,20	0,10-0,20	0,20-0,50	20 (10-25)	50 (30-80)	60 (30-120)
P7	NF/NS-EB845	0,10-0,15	0,1-0,20	0,10-0,20	0,20-0,50	20 (10-25)	50 (30-80)	60 (30-120)
P8	NF/NS-EB845	0,10-0,15	0,1-0,20	0,10-0,20	0,20-0,50	15 (10-20)	35 (20-60)	40 (20-80)
P11	NF/NS-EB845	0,10-0,15	0,1-0,20	0,10-0,20	0,20-0,50	15 (10-20)	35 (20-60)	40 (20-80)
P12	NF/NS-EB845	0,10-0,15	0,1-0,20	0,10-0,20	0,20-0,50	12 (8-15)	25 (15-45)	30 (15-65)
M1	NF/NS-EB845	0,08-0,15	0,10-0,15	0,10-0,20	0,20-0,50	12 (9-15)	25 (15-40)	35 (20-60)
M2	NF/NS-EB845	0,08-0,15	0,10-0,15	0,10-0,20	0,20-0,50	-	25 (15-40)	35 (20-60)
M3	NF/NS-EB845	0,08-0,15	0,10-0,15	0,10-0,20	0,20-0,50	-	25 (15-40)	35 (20-60)
M4	NF/NS-EB845	0,08-0,15	0,10-0,15	0,10-0,20	0,20-0,50	-	20 (10-30)	25 (15-40)
M5	NF/NS-EB845	0,08-0,15	0,10-0,15	0,10-0,20	0,20-0,50	-	20 (10-30)	25 (15-40)
K1	NF/NS-EB845	0,10-0,20	0,10-0,25	0,10-0,30	0,20-0,60	25 (15-30)	60 (40-100)	80 (30-150)
K2	NF/NS-EB845	0,10-0,20	0,10-0,25	0,10-0,30	0,20-0,60	-	25 (20-40)	40 (30-70)
K3	NF/NS-EB845	0,10-0,20	0,10-0,25	0,10-0,30	0,20-0,60	25 (15-30)	60 (40-100)	80 (30-150)
K4	NF/NS-EB845	0,10-0,20	0,10-0,25	0,10-0,30	0,20-0,60	25 (15-30)	45 (30-70)	70 (40-120)
K5	NF/NS-EB845	0,10-0,20	0,10-0,25	0,10-0,30	0,20-0,60	25 (15-30)	45 (30-70)	70 (40-120)
K6	NF/NS-EB845	0,10-0,20	0,10-0,25	0,10-0,30	0,20-0,60	-	60 (40-100)	80 (30-150)
K7	NF/NS-EB845	0,10-0,20	0,10-0,25	0,10-0,30	0,20-0,60	-	60 (40-100)	80 (30-150)
S1	NF/NS-EB845	0,08-0,15	0,10-0,15	0,10-0,20	0,20-0,30	-	15 (8-20)	20 (10-25)
S2	NF/NS-EB845	0,08-0,15	0,10-0,15	0,10-0,20	0,20-0,30	-	15 (8-20)	20 (10-25)
S3	NF/NS-EB845	0,08-0,15	0,10-0,15	0,10-0,20	0,20-0,30	-	15 (8-20)	20 (10-25)
S11	NF/NS-EB845	0,08-0,15	0,10-0,15	0,10-0,20	0,20-0,30	20 (15-30)	30 (15-40)	40 (20-50)
S12	NF/NS-EB845	0,08-0,15	0,10-0,15	0,10-0,20	0,20-0,30	20 (15-30)	30 (15-40)	40 (20-50)
S13	NF/NS-EB845	0,08-0,15	0,10-0,15	0,10-0,20	0,20-0,30	20 (15-30)	30 (15-40)	40 (20-50)
H3	NF/NS-EB845	0,08-0,15	0,10-0,15	0,10-0,20	0,20-0,30	-	-	10 (8-15)
H5	NF/NS-EB845	0,08-0,15	0,10-0,15	0,10-0,20	0,20-0,30	-	-	10 (8-15)
H7	NF/NS-EB845	0,08-0,15	0,10-0,15	0,10-0,20	0,20-0,30	-	-	10 (8-15)
H8	NF/NS-EB845	0,08-0,15	0,10-0,15	0,10-0,20	0,20-0,30	-	-	10 (8-15)
H11	NF/NS-EB845	0,08-0,15	0,10-0,15	0,10-0,20	0,20-0,30	-	-	10 (8-15)
H12	NF/NS-EB845	0,08-0,15	0,10-0,15	0,10-0,20	0,20-0,30	-	-	10 (8-15)
H21	NF/NS-EB845	0,08-0,15	0,10-0,15	0,10-0,20	0,20-0,30	-	-	10 (8-15)
H31	NF/NS-EB845	0,08-0,15	0,10-0,15	0,10-0,20	0,20-0,30	-	-	10 (8-15)
PM1	NF/NS-EB845	0,10-0,15	0,1-0,20	0,10-0,20	0,20-0,50	-	50 (30-80)	70 (40-100)
PM2	NF/NS-EB845	0,10-0,15	0,1-0,20	0,10-0,20	0,20-0,50	-	50 (30-80)	70 (40-100)
PM3	NF/NS-EB845	0,10-0,15	0,1-0,20	0,10-0,20	0,20-0,50	-	50 (30-80)	70 (40-100)

Cutting data – NF/NS-EB25

SMG		a _p (°)		f		v _c		
		z=4	z=6	z=4	z=6	H15	CP20	RX2000
P1	NF/NS-EB25	0,10-0,15	0,1-0,20	0,3-0,9	0,5-1,2	25 (15-30)	60 (30-100)	80 (30-150)
P2	NF/NS-EB25	0,10-0,15	0,1-0,20	0,3-0,9	0,5-1,2	25 (15-30)	60 (30-100)	80 (30-150)
P3	NF/NS-EB25	0,10-0,15	0,1-0,20	0,3-0,9	0,5-1,2	25 (15-30)	60 (30-100)	80 (30-150)
P4	NF/NS-EB25	0,10-0,15	0,1-0,20	0,3-0,7	0,5-1	20 (10-25)	50 (30-80)	60 (30-120)
P5	NF/NS-EB25	0,10-0,15	0,1-0,20	0,3-0,7	0,5-1	20 (10-25)	50 (30-80)	60 (30-120)
P6	NF/NS-EB25	0,10-0,15	0,1-0,20	0,3-0,7	0,5-1	20 (10-25)	50 (30-80)	60 (30-120)
P7	NF/NS-EB25	0,10-0,15	0,1-0,20	0,3-0,7	0,5-1	20 (10-25)	50 (30-80)	60 (30-120)
M1	NF/NS-EB25	0,08-0,15	0,10-0,15	0,3-0,7	0,5-1	-	25 (15-40)	35 (20-60)
K1	NF/NS-EB25	0,10-0,20	0,10-0,25	0,3-0,9	0,5-1,2	25 (15-30)	60 (40-100)	80 (30-150)
K2	NF/NS-EB25	0,10-0,20	0,10-0,25	0,3-0,9	0,5-1,2	-	25 (20-40)	40 (30-70)
K3	NF/NS-EB25	0,10-0,20	0,10-0,25	0,3-0,9	0,5-1,2	25 (15-30)	60 (40-100)	80 (30-150)
K4	NF/NS-EB25	0,10-0,20	0,10-0,25	0,3-0,9	0,5-1,2	25 (15-30)	45 (30-70)	70 (40-120)
K5	NF/NS-EB25	0,10-0,20	0,10-0,25	0,3-0,9	0,5-1,2	25 (15-30)	45 (30-70)	70 (40-120)
K6	NF/NS-EB25	0,10-0,20	0,10-0,25	0,3-0,9	0,5-1,2	-	60 (40-100)	80 (30-150)
K7	NF/NS-EB25	0,10-0,20	0,10-0,25	0,3-0,9	0,5-1,2	-	60 (40-100)	80 (30-150)
N1	NF/NS-EB25	0,10-0,20	0,10-0,30	0,3-0,9	0,5-1,2	50 (20-80)	-	-
N2	NF/NS-EB25	0,10-0,20	0,10-0,30	0,3-0,9	0,5-1,2	50 (20-80)	-	-
N3	NF/NS-EB25	0,10-0,20	0,10-0,30	0,3-0,9	0,5-1,2	50 (20-80)	-	-
N11	NF/NS-EB25	0,10-0,20	0,10-0,30	0,3-0,9	0,5-1,2	50 (20-80)	-	-
PM1	NF/NS-EB25	0,10-0,15	0,1-0,20	0,3-0,9	0,5-1,2	-	50 (30-80)	70 (40-100)
PM2	NF/NS-EB25	0,10-0,15	0,1-0,20	0,3-0,9	0,5-1,2	-	50 (30-80)	70 (40-100)
PM3	NF/NS-EB25	0,10-0,15	0,1-0,20	0,3-0,9	0,5-1,2	-	50 (30-80)	70 (40-100)

Cutting data – NF/NS...-EB45

SMG		a _p (Ø)		f		v _c		
		z=4	z=6	z=4	z=6	H15	CP20	RX2000
P1	NF/NS-EB45	0,10-0,15	0,1-0,20	0,10-0,30	0,20-0,60	25 (15-30)	60 (30-100)	80 (30-150)
P2	NF/NS-EB45	0,10-0,15	0,1-0,20	0,10-0,30	0,20-0,60	25 (15-30)	60 (30-100)	80 (30-150)
P3	NF/NS-EB45	0,10-0,15	0,1-0,20	0,10-0,30	0,20-0,60	25 (15-30)	60 (30-100)	80 (30-150)
P4	NF/NS-EB45	0,10-0,15	0,1-0,20	0,10-0,20	0,20-0,50	20 (10-25)	50 (30-80)	60 (30-120)
P5	NF/NS-EB45	0,10-0,15	0,1-0,20	0,10-0,20	0,20-0,50	20 (10-25)	50 (30-80)	60 (30-120)
P6	NF/NS-EB45	0,10-0,15	0,1-0,20	0,10-0,20	0,20-0,50	20 (10-25)	50 (30-80)	60 (30-120)
P7	NF/NS-EB45	0,10-0,15	0,1-0,20	0,10-0,20	0,20-0,50	20 (10-25)	50 (30-80)	60 (30-120)
P8	NF/NS-EB45	0,10-0,15	0,1-0,20	0,10-0,20	0,20-0,50	15 (10-20)	35 (20-60)	40 (20-80)
P11	NF/NS-EB45	0,10-0,15	0,1-0,20	0,10-0,20	0,20-0,50	15 (10-20)	35 (20-60)	40 (20-80)
P12	NF/NS-EB45	0,10-0,15	0,1-0,20	0,10-0,20	0,20-0,50	12 (8-15)	25 (15-45)	30 (15-65)
M1	NF/NS-EB45	0,08-0,15	0,10-0,15	0,10-0,20	0,20-0,50	12 (9-15)	25 (15-40)	35 (20-60)
M2	NF/NS-EB45	0,08-0,15	0,10-0,15	0,10-0,20	0,20-0,50	-	25 (15-40)	35 (20-60)
M3	NF/NS-EB45	0,08-0,15	0,10-0,15	0,10-0,20	0,20-0,50	-	25 (15-40)	35 (20-60)
M4	NF/NS-EB45	0,08-0,15	0,10-0,15	0,10-0,20	0,20-0,50	-	20 (10-30)	25 (15-40)
M5	NF/NS-EB45	0,08-0,15	0,10-0,15	0,10-0,20	0,20-0,50	-	20 (10-30)	25 (15-40)
K1	NF/NS-EB45	0,10-0,20	0,10-0,25	0,10-0,30	0,20-0,60	25 (15-30)	60 (40-100)	80 (30-150)
K2	NF/NS-EB45	0,10-0,20	0,10-0,25	0,10-0,30	0,20-0,60	-	25 (20-40)	40 (30-70)
K3	NF/NS-EB45	0,10-0,20	0,10-0,25	0,10-0,30	0,20-0,60	25 (15-30)	60 (40-100)	80 (30-150)
K4	NF/NS-EB45	0,10-0,20	0,10-0,25	0,10-0,30	0,20-0,60	25 (15-30)	45 (30-70)	70 (40-120)
K5	NF/NS-EB45	0,10-0,20	0,10-0,25	0,10-0,30	0,20-0,60	25 (15-30)	45 (30-70)	70 (40-120)
K6	NF/NS-EB45	0,10-0,20	0,10-0,25	0,10-0,30	0,20-0,60	-	60 (40-100)	80 (30-150)
K7	NF/NS-EB45	0,10-0,20	0,10-0,25	0,10-0,30	0,20-0,60	-	60 (40-100)	80 (30-150)
N1	NF/NS-EB45	0,10-0,20	0,10-0,30	0,10-0,30	0,20-0,60	50 (20-80)	-	80 (30-150)
N2	NF/NS-EB45	0,10-0,20	0,10-0,30	0,10-0,30	0,20-0,60	50 (20-80)	-	80 (30-150)
N3	NF/NS-EB45	0,10-0,20	0,10-0,30	0,10-0,30	0,20-0,60	50 (20-80)	-	80 (30-150)
N11	NF/NS-EB45	0,10-0,20	0,10-0,30	0,10-0,30	0,20-0,60	50 (20-80)	-	80 (30-150)
S1	NF/NS-EB45	0,08-0,15	0,10-0,15	0,10-0,20	0,20-0,30	-	15 (8-20)	20 (10-25)
S2	NF/NS-EB45	0,08-0,15	0,10-0,15	0,10-0,20	0,20-0,30	-	15 (8-20)	20 (10-25)
S3	NF/NS-EB45	0,08-0,15	0,10-0,15	0,10-0,20	0,20-0,30	-	15 (8-20)	20 (10-25)
S11	NF/NS-EB45	0,08-0,15	0,10-0,15	0,10-0,20	0,20-0,30	20 (15-30)	30 (15-40)	40 (20-50)
S12	NF/NS-EB45	0,08-0,15	0,10-0,15	0,10-0,20	0,20-0,30	20 (15-30)	30 (15-40)	40 (20-50)
S13	NF/NS-EB45	0,08-0,15	0,10-0,15	0,10-0,20	0,20-0,30	20 (15-30)	30 (15-40)	40 (20-50)
H3	NF/NS-EB45	0,08-0,15	0,10-0,15	0,10-0,20	0,20-0,30	-	-	10 (8-15)
H5	NF/NS-EB45	0,08-0,15	0,10-0,15	0,10-0,20	0,20-0,30	-	-	10 (8-15)
H7	NF/NS-EB45	0,08-0,15	0,10-0,15	0,10-0,20	0,20-0,30	-	-	10 (8-15)
H8	NF/NS-EB45	0,08-0,15	0,10-0,15	0,10-0,20	0,20-0,30	-	-	10 (8-15)
H11	NF/NS-EB45	0,08-0,15	0,10-0,15	0,10-0,20	0,20-0,30	-	-	10 (8-15)
H12	NF/NS-EB45	0,08-0,15	0,10-0,15	0,10-0,20	0,20-0,30	-	-	10 (8-15)
H21	NF/NS-EB45	0,08-0,15	0,10-0,15	0,10-0,20	0,20-0,30	-	-	10 (8-15)
H31	NF/NS-EB45	0,08-0,15	0,10-0,15	0,10-0,20	0,20-0,30	-	-	10 (8-15)
PM1	NF/NS-EB45	0,10-0,15	0,1-0,20	0,10-0,20	0,20-0,50	-	50 (30-80)	70 (40-100)
PM2	NF/NS-EB45	0,10-0,15	0,1-0,20	0,10-0,20	0,20-0,50	-	50 (30-80)	70 (40-100)
PM3	NF/NS-EB45	0,10-0,15	0,1-0,20	0,10-0,20	0,20-0,50	-	50 (30-80)	70 (40-100)
TS1	NF/NS-EB45	0,10-0,15	0,1-0,20	0,10-0,30	0,20-0,60	20 (15-25)	-	40 (20-60)
TS2	NF/NS-EB45	0,10-0,15	0,1-0,20	0,10-0,30	0,20-0,60	20 (15-25)	-	40 (20-60)
TS3	NF/NS-EB45	0,10-0,15	0,1-0,20	0,10-0,30	0,20-0,60	20 (15-25)	-	40 (20-60)
TS4	NF/NS-EB45	0,10-0,15	0,1-0,20	0,10-0,30	0,20-0,60	20 (15-25)	-	40 (20-60)
TP1	NF/NS-EB45	0,10-0,15	0,1-0,20	0,10-0,30	0,20-0,60	20 (15-25)	-	40 (20-60)
TP2	NF/NS-EB45	0,10-0,15	0,1-0,20	0,10-0,30	0,20-0,60	20 (15-25)	-	40 (20-60)
TP3	NF/NS-EB45	0,10-0,15	0,1-0,20	0,10-0,30	0,20-0,60	20 (15-25)	-	40 (20-60)
TP4	NF/NS-EB45	0,10-0,15	0,1-0,20	0,10-0,30	0,20-0,60	20 (15-25)	-	40 (20-60)
GR1	NF/NS-EB45	0,10-0,15	0,1-0,20	0,10-0,30	0,20-0,60	40 (80-20)	-	60 (30-120)

SMG = Seco material group

a_p = mm

f = mm/rev

v_c = m/min

All cutting data are start values

Cutting data – NF/NS...-EB45

SMG		a _p (Ø)		f		v _c			
		z=4	z=6	z=4	z=6	RN2010	RM2020	RM2090	RS2090
M1	NF/NS-EB45	0,08-0,15	0,10-0,15	0,10-0,20	0,20-0,50	-	25 (15-40)	40 (20-60)	-
M2	NF/NS-EB45	0,08-0,15	0,10-0,15	0,10-0,20	0,20-0,50	-	25 (15-40)	40 (20-60)	-
M3	NF/NS-EB45	0,08-0,15	0,10-0,15	0,10-0,20	0,20-0,50	-	25 (15-40)	40 (20-60)	-
M4	NF/NS-EB45	0,08-0,15	0,10-0,15	0,10-0,20	0,20-0,50	-	20 (10-30)	30 (15-40)	-
M5	NF/NS-EB45	0,08-0,15	0,10-0,15	0,10-0,20	0,20-0,50	-	20 (10-30)	30 (15-40)	-
N1	NF/NS-EB45	0,10-0,20	0,10-0,30	0,10-0,30	0,20-0,60	50 (20-80)	-	-	-
N2	NF/NS-EB45	0,10-0,20	0,10-0,30	0,10-0,30	0,20-0,60	50 (20-80)	-	-	-
N3	NF/NS-EB45	0,10-0,20	0,10-0,30	0,10-0,30	0,20-0,60	50 (20-80)	-	-	-
N11	NF/NS-EB45	0,10-0,20	0,10-0,30	0,10-0,30	0,20-0,60	50 (20-80)	-	-	-
S1	NF/NS-EB45	0,08-0,15	0,10-0,15	0,10-0,20	0,20-0,30	-	-	-	20 (10-25)
S2	NF/NS-EB45	0,08-0,15	0,10-0,15	0,10-0,20	0,20-0,30	-	-	-	20 (10-25)
S3	NF/NS-EB45	0,08-0,15	0,10-0,15	0,10-0,20	0,20-0,30	-	-	-	25 (10-25)
S11	NF/NS-EB45	0,08-0,15	0,10-0,15	0,10-0,20	0,20-0,30	-	-	-	30 (20-50)
S12	NF/NS-EB45	0,08-0,15	0,10-0,15	0,10-0,20	0,20-0,30	-	-	-	30 (20-50)
S13	NF/NS-EB45	0,08-0,15	0,10-0,15	0,10-0,20	0,20-0,30	-	-	-	30 (20-50)

Cutting data – NF/NS...-EB845

SMG		a _p (Ø)		f		v _c		
		z=4	z=6	z=4	z=6	RM2020	RM2090	RS2090
M1	NF/NS-EB845	0,08-0,15	0,10-0,15	0,10-0,20	0,20-0,50	25 (15-40)	40 (20-60)	-
M2	NF/NS-EB845	0,08-0,15	0,10-0,15	0,10-0,20	0,20-0,50	25 (15-40)	40 (20-60)	-
M3	NF/NS-EB845	0,08-0,15	0,10-0,15	0,10-0,20	0,20-0,50	25 (15-40)	40 (20-60)	-
M4	NF/NS-EB845	0,08-0,15	0,10-0,15	0,10-0,20	0,20-0,50	25 (10-30)	30 (15-40)	-
M5	NF/NS-EB845	0,08-0,15	0,10-0,15	0,10-0,20	0,20-0,50	25 (10-30)	30 (15-40)	-
S1	NF/NS-EB845	0,08-0,15	0,10-0,15	0,10-0,20	0,20-0,30	-	-	20 (10-25)
S2	NF/NS-EB845	0,08-0,15	0,10-0,15	0,10-0,20	0,20-0,30	-	-	20 (10-25)
S3	NF/NS-EB845	0,08-0,15	0,10-0,15	0,10-0,20	0,20-0,30	-	-	25 (10-25)
S11	NF/NS-EB845	0,08-0,15	0,10-0,15	0,10-0,20	0,20-0,30	-	-	30 (20-50)
S12	NF/NS-EB845	0,08-0,15	0,10-0,15	0,10-0,20	0,20-0,30	-	-	30 (20-50)
S13	NF/NS-EB845	0,08-0,15	0,10-0,15	0,10-0,20	0,20-0,30	-	-	30 (20-50)

SMG = Seco material group

a_p = mm

f = mm/rev

v_c = m/min

All cutting data are start values

Custom design – No waiting for quotation – Short delivery time

Custom Design is also available for Nanofix reamers and tool holders.

You can now quote for your own intermediate \varnothing reamer and tailor made Nanofix tool holder using the Seco Custom Design software.

Easy to use concept: Just indicate component min/max \varnothing or use ISO tolerance system available in the software.

Nanofix head designation is created automatically.

Custom Design gives you a number of advantages:

- No waiting for quotation! Price and delivery time is available instantly!
- Directly visualize your needs. No risk for misunderstandings
- Short delivery time

CUSTOM DESIGN
Version 1.8.2.1

Test mode (Exit) Seco mode Feedback

Reaming >> Nanofix >> Nanofix Monobloc Cutting Tool
Login English

Step 1: Tool Specification
Step 2: Request for Quotation

Inch:

	Min	Max
Material cutting choice	M3 / Medium alloy austenitic and duplex stainless steels	
Tolerance	ISO	
ISO Class	M	
ISO Quality	7	
Workpiece Diameter D	2.97	12.05
Geometry	EB45	
Grade	RM2090	
Reamer diameter D position :	45% of the workpiece tolerance	
Length of the reamer	Normal - NF06/NF10	
Number of Cutting edges Z	4	
DMM	6	
LUX	60	
OAL1	80	
OAL2	145	
LBN	80	
BD	16	
NFOF Holder Size	NFOF06	

Previous
Request quotation

Spare Parts

/

Designation
NF06-6M7-EB45, RM2090

Delivery Time
 Quantity: Send request
 Min Quantity: 2
 Max Quantity: 20

Regrinding instructions

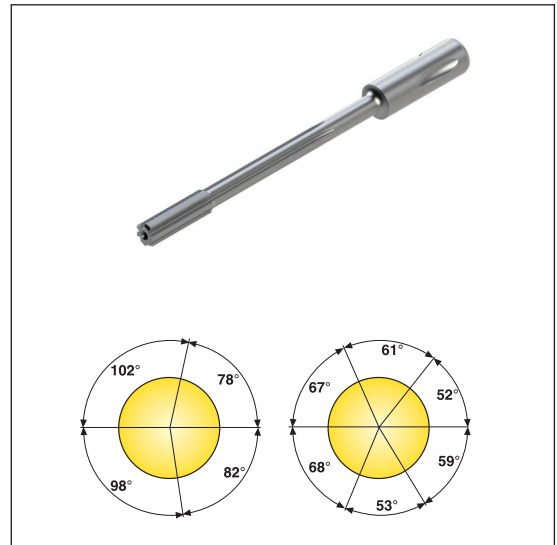
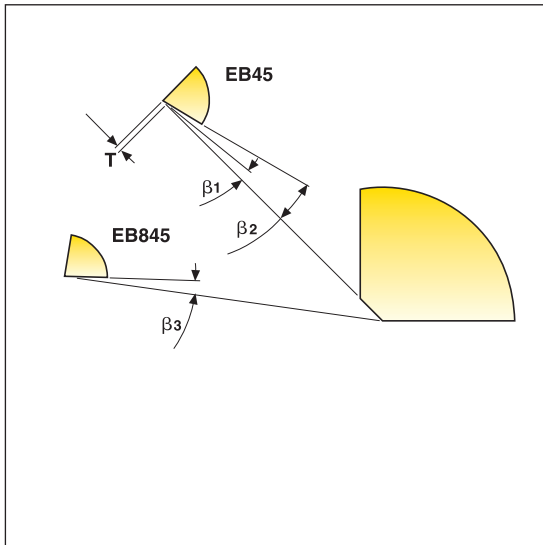

∅ Nanofix	β_1	β_2	β_3	t
2.97-12.050 mm	8°	25°	10°	0.15 mm

Specification:

Diamond grinding wheel
 Grain size:
 D6 for 1st clearance angle ($\beta_1 - \beta_3$)
 D64 for 2nd clearance angle (β_2)

Important

Regrinding reduces reamer diameter
 Recoating may produce oversized diameter
 Max run-out on lead chamfers 10 μ m



Bifix®	∅ Range	Reaming depth	Drill ∅ tolerance	Intermediate diameter	Surface finish (2)
<p>SR80 For through holes</p> 	5,900–60,500 mm	3–5–7 x D	IT 6-7	Yes, available through Custom design	R _a 0,2–0,8 μm
<p>SR81 For blind holes</p> 	7,875–60,500 mm	3–5–7 x D	IT 6-7	Yes, available through Custom design	R _a 0,2–0,8 μm
<p>SR82 For blind holes short version</p> 	7,875–60,500 mm	2–3–5 x D	IT 6-7	Yes, available through Custom design	R _a 0,2–0,8 μm

Code key – Reamers

Unless requested otherwise, reamers are designed to produce a diameter in the middle of the required tolerance.

Reamer type:

Type 80: Through hole

Type 81: Blind hole

Type 82: Blind hole, short version

Type of lead geometry

EN1, EN2, EN3

SR80 - 16,85 P6 - EN1 - R - 9

Hole diameter
and tolerance

Shank type: (to be stated when requested
style is not standard)
SR80 and SR81: R1 without flat is standard
SR82: R9 with flat is standard



Code key – Blades

Important: The reamer and the blade must have the same lead geometry.

Blade size:

P00, P0, P1

P2, P4

Cutting rake

angle:

0°, 6°, 12°

P2 - EN1 - 06 CP20

Type of lead geometry
EN1, EN2, EN3

Carbide grade:
CP20, H15

Set up and machining data

Rotating tool

Max. run-out recommended: 0,02 mm.

Precision holder is recommended : Hydraulic chuck, D-type collet chuck, 5672 collet chuck or shrink-fit.

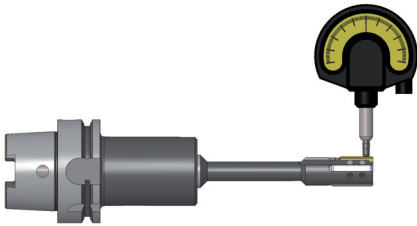

Stationary tool

Use a Seco floating holder, see page 375-379.

For optimal chip evacuation

Recommended blade orientation for static tools
(see drawing, view from front of tools).

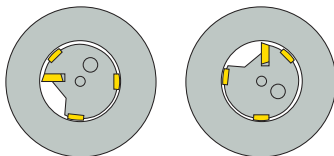

Coolant requirements

To reach maximum tool life and hole quality, the following coolant requirements should be observed.

Coolant through the tool is recommended. External coolant supply can be used if reaming depth $< 2 \times D$.

Quality soluble oil with 40% minimum mineral oil. Neat oil recommended for stainless steel.

Concentration minimum 6–8%.

Filtration 30–50 μm .

Volume min 0,5 l/min/mm in tool diameter. (Ex: Reamer $\varnothing 10$, min volume is 5 l/min).

Setting fixture

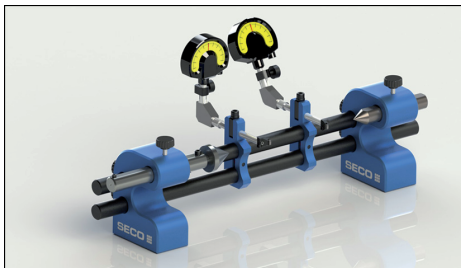

SF-60200-C160C190: Part No. 02885396

- Horizontal stand
- First choice for \varnothing smaller than 60 mm
- 2 clocks
- Maximum tool \varnothing : 60,5 mm
- Maximum tool length: 200 mm

Choice of blade – Select a lead geometry

EN1 - General information

Maximum machining allowance on \varnothing 0,5 mm.
Surface Finish + (R_a 0,3 - 0,8 μm)

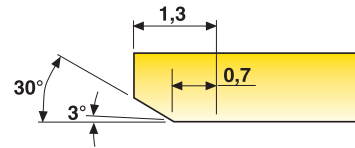

EN2 - Short lead

Maximum machining allowance on \varnothing 0,3 mm.
Surface finish (R_a 0,4–1,2 μm).
Maximum feed rate 0,2 mm/rev.
Only to be used when a short lead is required. Designed with end cutting.

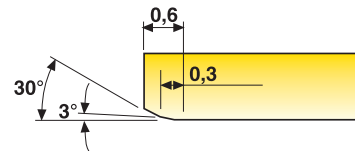

EN3 - Extreme surface finish

Maximum machining allowance on \varnothing 0,5 mm.
Surface finish (R_a 0,2–0,6 μm).
Suitable for all materials except aluminium.
To be used when R_a should be $< 0,3$ – $0,4$ μm .

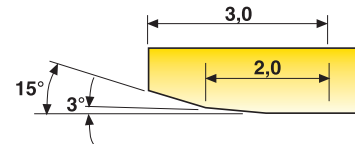

Note that reamer and blade must have the same lead geometry.

Grade and rake angle

Use the tables on page 490 to classify the workpiece material into SMG.

Use the blade and cutting data recommendation table on page 297-299 to choose grade and rake angle.

The blade programme is on page 295.

For through holes \varnothing 6H6-26H6 – Shank type R1, cylindrical without flat

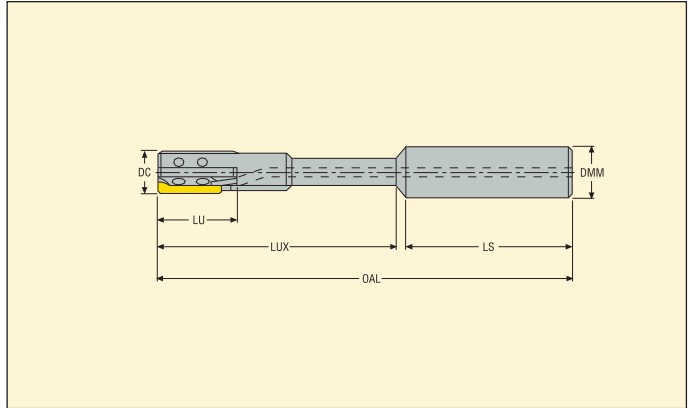

- Blade information on page(s) 295
- Internal 'through' coolant

DC	Ordering and Product No.	Designation	Dimensions in mm					Blade size
			OAL	LS	LUX	LU	DMM	
6	00024973	SR80-6H6-EN1	105	40	62	15	10	P00-EN1-xx
7	00024974	SR80-7H6-EN1	105	40	63	25	10	P0-EN1-xx
8	00024975	SR80-8H6-EN1	115	40	73	25	10	P0-EN1-xx
9	00024986	SR80-9H6-EN1	115	40	73	25	10	P1-EN1-xx
10	00024987	SR80-10H6-EN1	115	40	74	25	10	P1-EN1-xx
11	00024989	SR80-11H6-EN1	133	48	81	25	16	P1-EN1-xx
12	00024995	SR80-12H6-EN1	133	48	81	25	16	P1-EN1-xx
13	00024996	SR80-13H6-EN1	133	48	81	25	16	P2-EN1-xx
14	00024998	SR80-14H6-EN1	133	48	81	25	16	P2-EN1-xx
15	00024999	SR80-15H6-EN1	133	48	82	25	16	P2-EN1-xx
16	00025163	SR80-16H6-EN1	133	48	82	25	16	P2-EN1-xx
17	00025223	SR80-17H6-EN1	155	50	100	25	20	P2-EN1-xx
18	00025254	SR80-18H6-EN1	155	50	100	25	20	P2-EN1-xx
19	00025255	SR80-19H6-EN1	155	50	100	25	20	P2-EN1-xx
20	00025266	SR80-20H6-EN1	155	50	100	30	20	P4-EN1-xx
21	00025285	SR80-21H6-EN1	191	56	128	30	25	P4-EN1-xx
22	00025364	SR80-22H6-EN1	191	56	129	30	25	P4-EN1-xx
23	00025373	SR80-23H6-EN1	191	56	129	30	25	P4-EN1-xx
24	00025374	SR80-24H6-EN1	191	56	129	30	25	P4-EN1-xx
25	00025376	SR80-25H6-EN1	191	56	129	30	25	P4-EN1-xx
26	00025381	SR80-26H6-EN1	191	56	129	30	25	P4-EN1-xx

Spare Parts

For \varnothing (mm)	Clamp	Clamp screw	Support ball	Adjusting screw	Setting key	Torque key*	Torque value
6						-	-
7-8	SR-B0	LH2040	BB1.5	SH2020	0.9 SMS795	-	-
9	SR-B1	LH2540	BB2.0	SH2025	1.3 SMS795	H00-1305	0,5 Nm
10-12	SR-B2	LH2540	BB2.0	SH2525	1.3 SMS795	H00-1305	0,5 Nm
13-19	SR-B3	LH3050	BB2.5	SH2540	1.5 SMS795	H00-1509	0,9 Nm
20-60	SR-B5	LH4010	BB3.0	SH3060	2SMS795	H00-2020	2,0 Nm

*Torque key including blade.

For through holes \varnothing 27H6–60H6 – Shank type R1, cylindrical without flat



- Blade information on page(s) 295
- Internal 'through' coolant

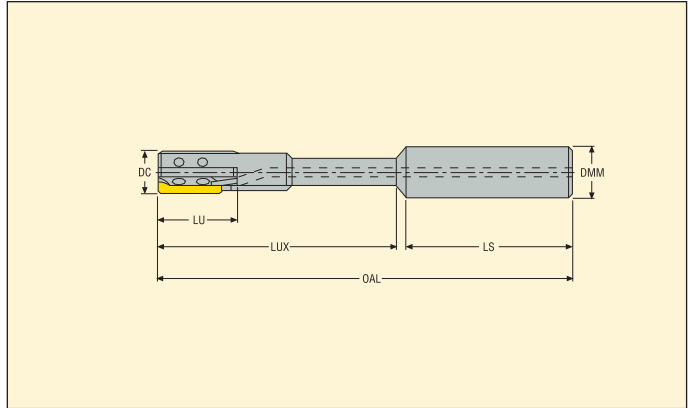

DC	Ordering and Product No.	Designation	Dimensions in mm					Blade size
			OAL	LS	LUX	LU	DMM	
27	00025382	SR80-27H6-EN1	221	56	159	30	25	P4-EN1-xx
28	00025383	SR80-28H6-EN1	221	56	159	30	25	P4-EN1-xx
29	00025384	SR80-29H6-EN1	221	56	159	30	25	P4-EN1-xx
30	00025411	SR80-30H6-EN1	221	56	159	30	25	P4-EN1-xx
31	00025431	SR80-31H6-EN1	221	56	160	30	25	P4-EN1-xx
32	00025434	SR80-32H6-EN1	221	56	160	30	25	P4-EN1-xx
34	00025438	SR80-34H6-EN1	226	56	165	30	25	P4-EN1-xx
35	00025441	SR80-35H6-EN1	226	56	165	30	25	P4-EN1-xx
36	00025442	SR80-36H6-EN1	226	56	166	30	25	P4-EN1-xx
38	00025444	SR80-38H6-EN1	226	56	166	30	25	P4-EN1-xx
40	00025446	SR80-40H6-EN1	226	56	166	30	25	P4-EN1-xx
42	00025447	SR80-42H6-EN1	226	56	167	30	25	P4-EN1-xx
44	00025449	SR80-44H6-EN1	226	56	167	30	25	P4-EN1-xx
48	00025451	SR80-48H6-EN1	226	56	168	30	25	P4-EN1-xx
50	00025455	SR80-50H6-EN1	226	56	168	30	25	P4-EN1-xx
52	00025456	SR80-52H6-EN1	226	56	169	30	25	P4-EN1-xx
54	00025475	SR80-54H6-EN1	226	56	169	30	25	P4-EN1-xx
58	00025479	SR80-58H6-EN1	226	56	169	30	25	P4-EN1-xx
60	00025514	SR80-60H6-EN1	226	56	169	30	25	P4-EN1-xx

Spare Parts

For \varnothing (mm)	Clamp	Clamp screw	Support ball	Adjusting screw	Setting key	Torque key*	Torque value
20-60							2,0 Nm

*Torque key including blade.

For through holes –Intermediate diameter – Shank type R1, cylindrical without flat



- Blade information on page(s) 295
- Important! Reamer and blade must have the same lead geometry
- For choice of lead geometry EN1, EN2 or EN3 see page(s) 286

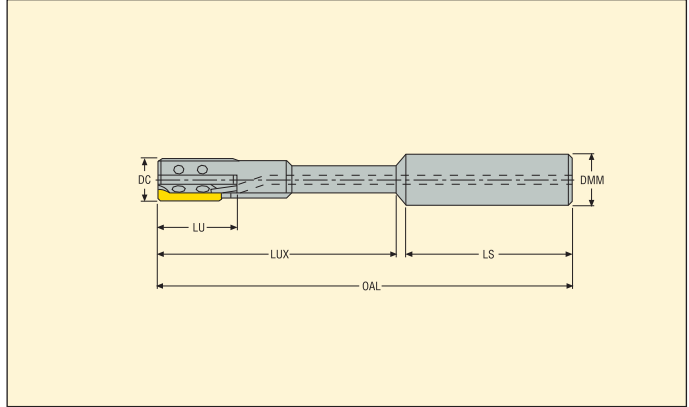

DC	Designation	Dimensions in mm					Blade size
		OAL	LS	LUX	LU	DMM	
5,900-6,874	SR80-x.xxx-EN	105	40	62	15	10	P00-EN-xx
6,875-7,874	SR80-x.xxx-EN	105	40	63	15	10	P0-EN-xx
7,875-8,749	SR80-x.xxx-EN	115	40	73	25	10	P0-EN-xx
8,750-10,749	SR80-x.xxx-EN	115	40	73	25	10	P1-EN-xx
10,750-12,749	SR80-xx.xxx-EN	133	48	81	25	16	P1-EN-xx
12,750-16,749	SR80-xx.xxx-EN	133	48	81	25	16	P2-EN-xx
16,750-19,499	SR80-xx.xxx-EN	155	50	100	25	20	P2-EN-xx
19,500-20,499	SR80-xx.xxx-EN	155	50	100	30	20	P4-EN-xx
20,500-26,499	SR80-xx.xxx-EN	191	56	129	30	25	P4-EN-xx
26,500-32,499	SR80-xx.xxx-EN	221	56	160	30	25	P4-EN-xx
32,500-38,499	SR80-xx.xxx-EN	226	56	165	30	25	P4-EN-xx
38,500-40,499	SR80-xx.xxx-EN	226	56	166	30	25	P4-EN-xx
40,500-44,499	SR80-xx.xxx-EN	226	56	167	30	25	P4-EN-xx
44,500-50,499	SR80-xx.xxx-EN	226	56	168	30	25	P4-EN-xx
50,500-60,500	SR80-xx.xxx-EN	226	56	169	30	25	P4-EN-xx

Spare Parts

For \varnothing (mm)	Clamp	Clamp screw	Support ball	Adjusting screw	Setting key	Torque key*
5,900-6,299						
5,900-6,299	SR-B02	M2T	BB1.5	SH2020	T06P-2+0.9 SMS795	-
6,300-6,874	SR-B01	M2T	BB1.5	SH2020	T06P-2+0.9 SMS795	-
6,875-8,749	SR-B0	LH2040	BB1.5	SH2020	0.9 SMS795	-
8,750-9,749	SR-B1	LH2540	BB2.0	SH2525	1.3 SMS795	H00-1305
9,750-12,749	SR-B2	LH2540	BB2.0	SH2525	1.3 SMS795	H00-1305
12,750-19,499	SR-B3	LH3050	BB2.5	SH3040	1.5 SMS795	H00-1509
19,500-60,500	SR-B5	LH4010	BB3.0	SH4060	2SMS795	H00-2020

Note! When ordering reamers for intermediate diameter, please state: \varnothing and tolerance of bore to be reamed, lead geometry (EN1, EN2 or EN3).
Ordering example: SR80-11.50 H7-EN2, P1-EN2-06, CP20.
 *Torque key including blade.

For blind holes \varnothing 8H6–26H6 – Shank type R1, cylindrical without flat

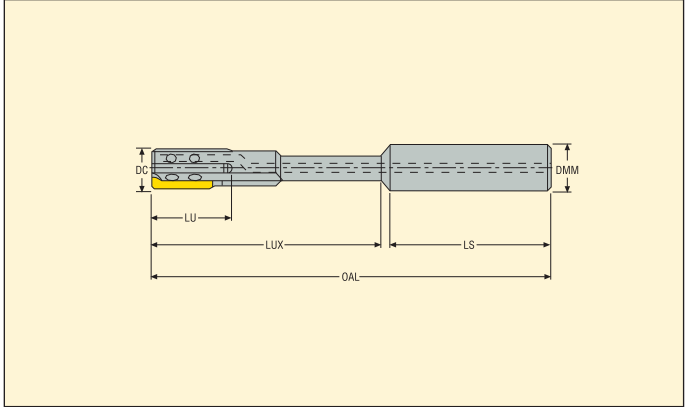

- Blade information on page(s) 295
- Internal 'through' coolant

DC	Ordering and Product No.	Designation	Dimensions in mm					Blade size
			OAL	LS	LUX	LU	DMM	
8	00025517	SR81-8H6-EN1	115	40	73	25	10	P0-EN1-xx
9	00025527	SR81-9H6-EN1	115	40	73	25	10	P1-EN1-xx
11	00025539	SR81-11H6-EN1	133	48	81	25	16	P1-EN1-xx
13	00025556	SR81-13H6-EN1	133	48	81	25	16	P2-EN1-xx
14	00025557	SR81-14H6-EN1	133	48	81	25	16	P2-EN1-xx
15	00025571	SR81-15H6-EN1	133	48	82	25	16	P2-EN1-xx
16	00025577	SR81-16H6-EN1	133	48	82	25	16	P2-EN1-xx
17	00025578	SR81-17H6-EN1	155	50	100	25	20	P2-EN1-xx
18	00025753	SR81-18H6-EN1	155	50	100	25	20	P2-EN1-xx
19	00025825	SR81-19H6-EN1	155	50	100	25	20	P2-EN1-xx
20	00027069	SR81-20H6-EN1	155	50	100	30	20	P4-EN1-xx
21	00027076	SR81-21H6-EN1	191	56	128	30	25	P4-EN1-xx
22	00027197	SR81-22H6-EN1	191	56	129	30	25	P4-EN1-xx
23	00027466	SR81-23H6-EN1	191	56	129	30	25	P4-EN1-xx
25	00027614	SR81-25H6-EN1	191	56	129	30	25	P4-EN1-xx
26	00027847	SR81-26H6-EN1	191	56	129	30	25	P4-EN1-xx

Spare Parts

For \varnothing (mm)	Clamp	Clamp screw	Support ball	Adjusting screw	Setting key	Torque key*	Torque value
8						-	-
9	SR-B1	LH2540	BB2.0	SH2525	1.3 SMS795	H00-1305	0,5 Nm
10-12	SR-B2	LH2540	BB2.0	SH2525	1.3 SMS795	H00-1305	0,5 Nm
13-19	SR-B3	LH3050	BB2.5	SH3040	1.5 SMS795	H00-1509	0,9 Nm
20-60	SR-B5	LH4010	BB3.0	SH4060	2SMS795	H00-2020	2,0 Nm

*Torque key including blade.

For blind holes \varnothing 27H6–60H6 – Shank type R1, cylindrical without flat



- Blade information on page(s) 295
- Internal 'through' coolant

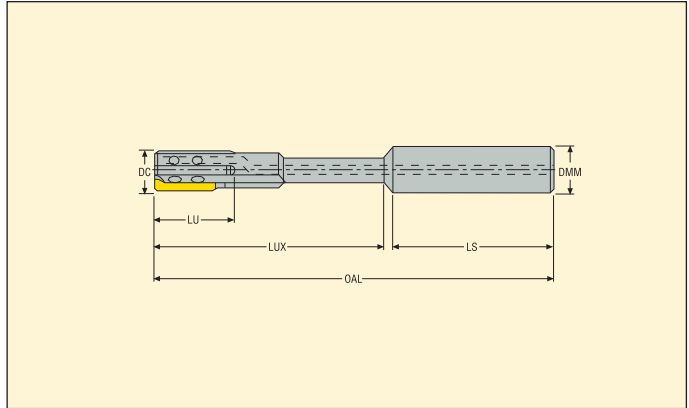

DC	Ordering and Product No.	Designation	Dimensions in mm					Blade size
			OAL	LS	LUX	LU	DMM	
27	00028229	SR81-27H6-EN1	221	56	159	30	25	P4-EN1-xx
28	00028335	SR81-28H6-EN1	221	56	159	30	25	P4-EN1-xx
29	00028628	SR81-29H6-EN1	221	56	159	30	25	P4-EN1-xx
30	00028629	SR81-30H6-EN1	221	56	159	30	25	P4-EN1-xx
31	00028631	SR81-31H6-EN1	221	56	160	30	25	P4-EN1-xx
32	00028633	SR81-32H6-EN1	221	56	160	30	25	P4-EN1-xx
34	00028634	SR81-34H6-EN1	226	56	165	30	25	P4-EN1-xx
35	00028636	SR81-35H6-EN1	226	56	165	30	25	P4-EN1-xx
36	00028637	SR81-36H6-EN1	226	56	166	30	25	P4-EN1-xx
38	00028638	SR81-38H6-EN1	226	56	166	30	25	P4-EN1-xx
40	00028639	SR81-40H6-EN1	226	56	166	30	25	P4-EN1-xx
42	00028643	SR81-42H6-EN1	226	56	167	30	25	P4-EN1-xx
44	00028644	SR81-44H6-EN1	226	56	167	30	25	P4-EN1-xx
48	00028648	SR81-48H6-EN1	226	56	168	30	25	P4-EN1-xx
50	00028649	SR81-50H6-EN1	226	56	168	30	25	P4-EN1-xx
52	00028651	SR81-52H6-EN1	226	56	169	30	25	P4-EN1-xx
54	00028653	SR81-54H6-EN1	226	56	169	30	25	P4-EN1-xx
58	00028654	SR81-58H6-EN1	226	56	169	30	25	P4-EN1-xx
60	00028656	SR81-60H6-EN1	226	56	169	30	25	P4-EN1-xx

Spare Parts

For \varnothing (mm)	Clamp	Clamp screw	Support ball	Adjusting screw	Setting key	Torque key*	Torque value
20-60							
	SR-B5	LH4010	BB3.0	SH4060	2SMS795	H00-2020	2,0 Nm

*Torque key including blade.

For blind holes – Intermediate diameter – Shank type R1, cylindrical without flat



- Blade information on page(s) 295
- Important! Reamer and blade must have the same lead geometry
- For choice of lead geometry EN1, EN2 or EN3 see page(s) 286

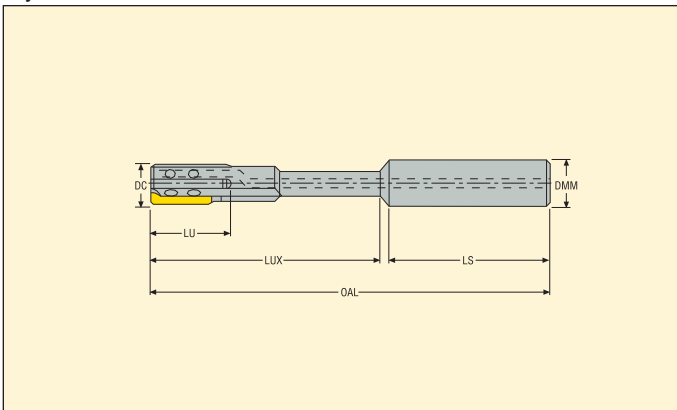

DC	Designation	Dimensions in mm					Blade size
		OAL	LS	LUX	LU	DMM	
7,875-8,749	SR81-x.xxx-EN	115	40	73	25	10	P0-EN-xx
8,750-10,749	SR81-x.xxx-EN	115	40	73	25	10	P1-EN-xx
10,750-12,749	SR81-x.xxx-EN	133	48	81	25	16	P1-EN-xx
12,750-16,749	SR81-x.xxx-EN	133	48	81	25	16	P2-EN-xx
16,750-19,499	SR81-x.xxx-EN	155	50	100	25	20	P2-EN-xx
19,500-20,499	SR81-x.xxx-EN	155	50	100	30	20	P4-EN-xx
20,500-26,499	SR81-x.xxx-EN	191	56	129	30	25	P4-EN-xx
26,500-32,499	SR81-x.xxx-EN	221	56	160	30	25	P4-EN-xx
32,500-38,499	SR81-x.xxx-EN	226	56	165	30	25	P4-EN-xx
38,500-40,499	SR81-x.xxx-EN	226	56	166	30	25	P4-EN-xx
40,500-44,499	SR81-x.xxx-EN	226	56	167	30	25	P4-EN-xx
44,500-50,499	SR81-x.xxx-EN	226	56	168	30	25	P4-EN-xx
50,500-60,500	SR81-x.xxx-EN	226	56	169	30	25	P4-EN-xx

Spare Parts

For Ø (mm)	Clamp	Clamp screw	Support ball	Adjusting screw	Setting key	Torque key*
7,875-8,749						-
8,750-9,749	SR-B1	LH2540	BB2.0	SH2525	1.3 SMS795	H00-1305
9,750-12,749	SR-B2	LH2540	BB2.0	SH2525	1.3 SMS795	H00-1305
12,750-19,499	SR-B3	LH3050	BB2.5	SH3040	1.5 SMS795	H00-1509
19,500-60,500	SR-B5	LH4010	BB3.0	SH4060	2SMS795	H00-2020

Note! When ordering reamers for intermediate diameter, please state: Ø and tolerance of bore to be reamed, lead geometry (EN1, EN2 or EN3).

Ordering example: SR81-11.50 H7-EN2, P1-EN2-06, CP20.

*Torque key including blade.

For blind holes – Short range for turning applications – Shank type R9, cylindrical with flat



- Blade information on page(s) 295
- Important! Reamer and blade must have the same lead geometry
- For choice of lead geometry EN1, EN2 or EN3 see page(s) 286

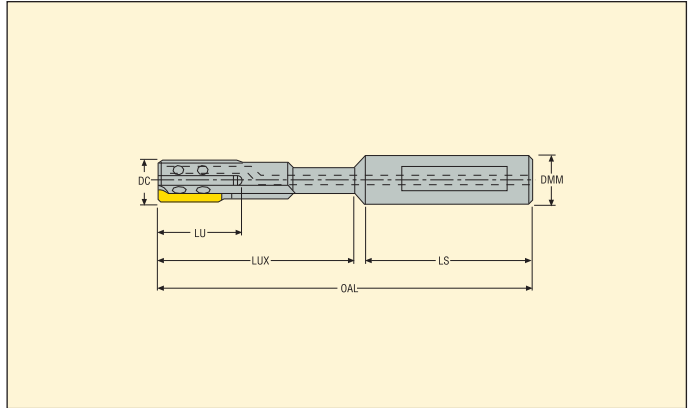

DC	Designation	Dimensions in mm					Blade size
		OAL	LS	LUX	LU	DMM	
7,875-8,749	SR82-x.xxx-EN	95	40	53	25	10	P0-EN-xx
8,750-10,749	SR82-x.xxx-EN	95	40	53	25	10	P1-EN-xx
10,750-12,749	SR82-x.xxx-EN	113	48	61	25	16	P1-EN-xx
12,750-16,749	SR82-x.xxx-EN	113	48	61	25	16	P2-EN-xx
16,750-19,499	SR82-x.xxx-EN	115	50	60	25	20	P2-EN-xx
19,500-20,499	SR82-x.xxx-EN	115	50	60	30	20	P4-EN-xx
20,500-32,499	SR82-x.xxx-EN	151	56	89	30	25	P4-EN-xx
32,500-36,499	SR82-x.xxx-EN	166	56	105	30	25	P4-EN-xx
36,500-40,499	SR82-x.xxx-EN	166	56	106	30	25	P4-EN-xx
40,500-44,499	SR82-x.xxx-EN	166	56	107	30	25	P4-EN-xx
44,500-50,499	SR82-x.xxx-EN	166	56	108	30	25	P4-EN-xx
50,500-60,500	SR82-x.xxx-EN	166	56	109	30	25	P4-EN-xx

Spare Parts

For \varnothing (mm)	Clamp	Clamp screw	Support ball	Adjusting screw	Setting key	Torque key*
7,875-8,749						–
8,750-9,749	SR-B1	LH2540	BB2.0	SH2525	1.3 SMS795	H00-1305
9,750-12,749	SR-B2	LH2540	BB2.0	SH2525	1.3 SMS795	H00-1305
12,750-19,499	SR-B3	LH3050	BB2.5	SH3040	1.5 SMS795	H00-1509
19,500-60,500	SR-B5	LH4010	BB3.0	SH4060	2SMS795	H00-2020

Note! When ordering reamers for intermediate diameter, please state: \varnothing and tolerance of bore to be reamed, lead geometry (EN1, EN2 or EN3).

Ordering example: SR82-11.50 H7EN2, P1-EN2-06, CP20



*Torque key including blade.

Optimization/Grades

Use the blade selection table to choose alternative blades for higher productivity or better security

Blade size	Steel	Stainless steel	Cast iron	Non-ferrous	Aluminium	Wear resistance ↔ Toughness			Designation	
						Productivity	Versatility	Security	Blade	Grade
P00, P0, P1, P2, P4										
			•	•				X	Pxx-ENx-00	H15
	•		•	•	•			X	Pxx-ENx-06	H15
		•		•	•			X	Pxx-ENx-12	H15
	•					X			Pxx-ENx-00	CP20
	•		•				X		Pxx-ENx-06	CP20
	•	•					X		Pxx-ENx-12	CP20
	•		•			X			Pxx-ENx-00	CP15
	•		•			X			Pxx-ENx-06	CP15
	•	•		•	•	X			Pxx-ENx-12	CP15

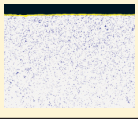
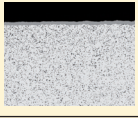
Grades

	CP15	<p>Coated A wear-resistant coated grade alternative to CP20. For optimization in cast iron and steels. Also suitable for non-ferrous. Ti(C, N)</p>
	CP20	<p>Coated A versatile coated grade suitable for most materials, except aluminum. TiN</p>
	H15	<p>Uncoated A tough micrograin grade for all materials. Suitable for fine-reaming operations due to edge sharpness.</p>

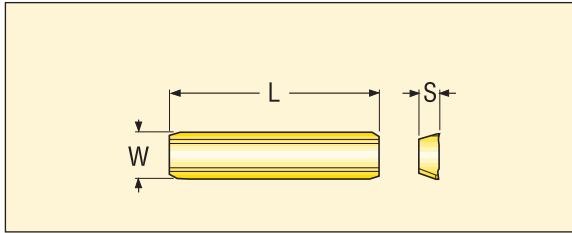

Size	Dimensions in mm		
	W	L	S
P0	2,5	20,0	1,2
P00	1,5	11,0	1,0
P1	3,0	20,0	1,5
P2	4,5	20,0	2,0
P4	7,0	25,0	2,3

Inserts	Designation	Grades	
		H15	CP20
P00	P00-EN1-0	00098228	00098243
	P00-EN1-06	00091785	00091763
	P00-EN1-12	00097298	00091970
	P00-EN2-0	00098233	00098248
	P00-EN2-06	00098159	00098169
	P00-EN2-12	00098164	00098174
	P00-EN3-0	00098238	00098253
	P00-EN3-06	00098184	00098194
	P00-EN3-12	00098189	00098427
P0	P0-EN1-0	00098229	00098244
	P0-EN1-06	00091786	00091762
	P0-EN1-12	00097299	00091971
	P0-EN2-0	00098234	00098249
	P0-EN2-06	00098160	00098170
	P0-EN2-12	00098165	00098175
	P0-EN3-0	00098239	00098254
	P0-EN3-06	00098185	00098195
	P0-EN3-12	00098190	00098200
P1	P1-EN1-0	00098230	00098245
	P1-EN1-06	00091787	00091764
	P1-EN1-12	00097300	00091972
	P1-EN2-0	00098235	00098250
	P1-EN2-06	00098161	00098171
	P1-EN2-12	00098166	00098176
	P1-EN3-0	00098240	00098255
	P1-EN3-06	00098186	00094702
	P1-EN3-12	00098191	00098201
P2	P2-EN1-0	00098231	00098246
	P2-EN1-06	00091788	00091765
	P2-EN1-12	00097301	00091973
	P2-EN2-0	00098236	00098251
	P2-EN2-06	00098162	00098172
	P2-EN2-12	00098167	00098177
	P2-EN3-0	00098241	00098256
	P2-EN3-06	00098187	00098197
	P2-EN3-12	00098192	00098202
P4	P4-EN1-0	00098232	00098247
	P4-EN1-06	00091789	00091766
	P4-EN1-12	00098128	00091974
	P4-EN2-0	00098237	00098252
	P4-EN2-06	00098163	00098173
	P4-EN2-12	00098168	00098178
	P4-EN3-0	00098242	00098257
	P4-EN3-06	00098188	00098198
	P4-EN3-12	00098193	00098203

■ Stock standard □ Non stock standard. Subject to change refer to current price- and stock-list.

Custom design – No waiting for quotation – Short delivery time

Custom Design is also available for Bifix reamers and tool holders.

You can now quote for your own intermediate \varnothing reamer and tailor made Bifix tool holder using the Seco Custom Design software.

Easy to use concept: Just indicate component min/max \varnothing or use ISO tolerance system available in the software.

Bifix head designation is created automatically.

Custom Design gives you a number of advantages:

- No waiting for quotation! Price and delivery time is available instantly!
- Directly visualize your needs. No risk for misunderstandings
- Short delivery time



CUSTOM DESIGN

Version 1.7.9.6

Reaming >> Bifix >> Which Bifix to choose ?
Test mode (Exit) Seco mode Feedback

Back
Start Page
Login
English

Print this page

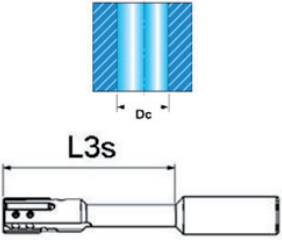

Inch:

	Min	Max	
Hole	Through hole - SR80		
Seco Material Group N°	1-4		i
Tolerance	ISO		
ISO Class	H		
ISO Quality	6		
Dc	5.9	60.5	8
L3s	73		
Bifix type	SR80		
Lead geometry choice	EN1		i
Shank type	R1		

Previous
Request quotation

Spare Parts

Note: inserts have to be ordered separately

Designation
SR80-8H6-EN1

Delivery Time

 Quantity: Send request

Cutting data – Pxx-EN1/EN2-00

SMG		a _p (Ø)		f	v _c	
		Ø < 9	Ø ≥ 9		CP20	CP15
P5	Pxx-EN1/EN2-00	0,10-0,15	0,10-0,20	0,10-0,30	40 (30-50)	-
P6	Pxx-EN1/EN2-00	0,10-0,15	0,10-0,20	0,10-0,30	40 (30-50)	-
P7	Pxx-EN1/EN2-00	0,10-0,15	0,10-0,20	0,10-0,30	40 (30-50)	-
K1	Pxx-EN1/EN2-00	0,10-0,20	0,10-0,30	0,10-0,30	90 (80-100)	120 (80-150)
K2	Pxx-EN1/EN2-00	0,10-0,20	0,10-0,30	0,10-0,30	35 (25-50)	50 (25-70)
K3	Pxx-EN1/EN2-00	0,10-0,20	0,10-0,30	0,10-0,30	90 (80-100)	120 (80-150)
K4	Pxx-EN1/EN2-00	0,10-0,20	0,10-0,30	0,10-0,30	70 (60-80)	90 (80-100)
K5	Pxx-EN1/EN2-00	0,10-0,20	0,10-0,30	0,10-0,30	70 (60-80)	90 (80-100)
K6	Pxx-EN1/EN2-00	0,10-0,20	0,10-0,30	0,10-0,30	90 (80-100)	120 (80-150)
K7	Pxx-EN1/EN2-00	0,10-0,20	0,10-0,30	0,10-0,30	90 (80-100)	120 (80-150)
PM1	Pxx-EN1/EN2-00	0,10-0,20	0,10-0,30	0,10-0,30	50 (25-70)	-
PM2	Pxx-EN1/EN2-00	0,10-0,20	0,10-0,30	0,10-0,30	50 (25-70)	-
PM3	Pxx-EN1/EN2-00	0,10-0,20	0,10-0,30	0,10-0,30	50 (25-70)	-

Cutting data – Pxx-EN1/EN2-06

SMG		a _p (Ø)		f	v _c		
		Ø < 9	Ø ≥ 9		H15	CP20	CP15
P1	Pxx-EN1/EN2-06	0,10-0,15	0,10-0,20	0,10-0,30	40 (30-60)	105 (90-120)	120 (90-150)
P2	Pxx-EN1/EN2-06	0,10-0,15	0,10-0,20	0,10-0,30	40 (30-60)	105 (90-120)	120 (90-150)
P3	Pxx-EN1/EN2-06	0,10-0,15	0,10-0,20	0,10-0,30	40 (30-60)	105 (90-120)	120 (90-150)
P4	Pxx-EN1/EN2-06	0,10-0,15	0,10-0,20	0,10-0,30	35 (25-40)	60 (40-70)	80 (60-100)
P5	Pxx-EN1/EN2-06	0,10-0,15	0,10-0,20	0,10-0,30	35 (25-40)	60 (40-70)	80 (60-100)
P6	Pxx-EN1/EN2-06	0,10-0,15	0,10-0,20	0,10-0,30	35 (25-40)	60 (40-70)	80 (60-100)
P7	Pxx-EN1/EN2-06	0,10-0,15	0,10-0,20	0,10-0,30	35 (25-40)	60 (40-70)	80 (60-100)
P8	Pxx-EN1/EN2-06	0,10-0,15	0,10-0,20	0,10-0,30	30 (25-40)	50 (30-60)	60 (40-70)
P11	Pxx-EN1/EN2-06	0,10-0,15	0,10-0,20	0,10-0,30	30 (25-40)	50 (30-60)	60 (40-70)
P12	Pxx-EN1/EN2-06	0,10-0,15	0,10-0,20	0,10-0,30	25 (20-30)	40 (25-45)	45 (30-55)
M1	Pxx-EN1/EN2-06	0,10-0,15	0,10-0,20	0,10-0,30	25 (20-30)	35 (25-40)	35 (25-40)
M2	Pxx-EN1/EN2-06	0,10-0,15	0,10-0,20	0,10-0,30	25 (20-30)	35 (25-40)	35 (25-40)
M3	Pxx-EN1/EN2-06	0,10-0,15	0,10-0,20	0,10-0,30	25 (20-30)	35 (25-40)	35 (25-40)
M4	Pxx-EN1/EN2-06	0,10-0,15	0,10-0,20	0,10-0,30	20 (15-30)	30 (25-40)	30 (25-40)
M5	Pxx-EN1/EN2-06	0,10-0,15	0,10-0,20	0,10-0,30	20 (15-30)	30 (25-40)	30 (25-40)
K1	Pxx-EN1/EN2-06	0,10-0,20	0,10-0,30	0,10-0,30	-	90 (80-100)	120 (80-150)
K2	Pxx-EN1/EN2-06	0,10-0,20	0,10-0,30	0,10-0,30	-	35 (25-50)	50 (25-70)
K3	Pxx-EN1/EN2-06	0,10-0,20	0,10-0,30	0,10-0,30	-	90 (80-100)	120 (80-150)
K4	Pxx-EN1/EN2-06	0,10-0,20	0,10-0,30	0,10-0,30	-	70 (60-80)	90 (80-100)
K5	Pxx-EN1/EN2-06	0,10-0,20	0,10-0,30	0,10-0,30	-	70 (60-80)	90 (80-100)
K6	Pxx-EN1/EN2-06	0,10-0,20	0,10-0,30	0,10-0,30	-	90 (80-100)	120 (80-150)
K7	Pxx-EN1/EN2-06	0,10-0,20	0,10-0,30	0,10-0,30	-	90 (80-100)	120 (80-150)
N11	Pxx-EN1/EN2-06	0,10-0,30	0,20-0,50	0,10-0,30	65 (50-150)	90 (70-150)	-
S1	Pxx-EN1/EN2-06	0,10-0,15	0,10-0,20	0,10-0,30	-	25 (15-30)	-
S2	Pxx-EN1/EN2-06	0,10-0,15	0,10-0,20	0,10-0,30	-	25 (15-30)	-
S3	Pxx-EN1/EN2-06	0,10-0,15	0,10-0,20	0,10-0,30	-	25 (15-30)	-
PM1	Pxx-EN1/EN2-06	0,10-0,20	0,10-0,30	0,10-0,30	-	50 (25-70)	-
PM2	Pxx-EN1/EN2-06	0,10-0,20	0,10-0,30	0,10-0,30	-	50 (25-70)	-
PM3	Pxx-EN1/EN2-06	0,10-0,20	0,10-0,30	0,10-0,30	-	50 (25-70)	-

SMG = Seco material group

a_p = mm

f = mm/rev

v_c = m/min

All cutting data are start values

Cutting data – Pxx-EN1/EN2-12

SMG		a_p (Ø)		f	v_c		
		Ø < 9	Ø ≥ 9		H15	CP20	CP15
P1	Pxx-EN1/EN2-12	0,10-0,15	0,10-0,20	0,10-0,30	40 (30-60)	105 (90-120)	120 (90-150)
P2	Pxx-EN1/EN2-12	0,10-0,15	0,10-0,20	0,10-0,30	40 (30-60)	105 (90-120)	120 (90-150)
P3	Pxx-EN1/EN2-12	0,10-0,15	0,10-0,20	0,10-0,30	40 (30-60)	105 (90-120)	120 (90-150)
P4	Pxx-EN1/EN2-12	0,10-0,15	0,10-0,20	0,10-0,30	35 (25-40)	60 (40-70)	80 (60-100)
P5	Pxx-EN1/EN2-12	0,10-0,15	0,10-0,20	0,10-0,30	35 (25-40)	60 (40-70)	80 (60-100)
P6	Pxx-EN1/EN2-12	0,10-0,15	0,10-0,20	0,10-0,30	35 (25-40)	60 (40-70)	80 (60-100)
P7	Pxx-EN1/EN2-12	0,10-0,15	0,10-0,20	0,10-0,30	35 (25-40)	60 (40-70)	80 (60-100)
P8	Pxx-EN1/EN2-12	0,10-0,15	0,10-0,20	0,10-0,30	30 (25-40)	50 (30-60)	60 (40-70)
P11	Pxx-EN1/EN2-12	0,10-0,15	0,10-0,20	0,10-0,30	30 (25-40)	50 (30-60)	60 (40-70)
P12	Pxx-EN1/EN2-12	0,10-0,15	0,10-0,20	0,10-0,30	25 (20-30)	40 (25-45)	45 (30-55)
M1	Pxx-EN1/EN2-12	0,10-0,15	0,10-0,20	0,10-0,30	25 (20-30)	35 (25-40)	35 (25-40)
M2	Pxx-EN1/EN2-12	0,10-0,15	0,10-0,20	0,10-0,30	25 (20-30)	35 (25-40)	35 (25-40)
M3	Pxx-EN1/EN2-12	0,10-0,15	0,10-0,20	0,10-0,30	25 (20-30)	35 (25-40)	35 (25-40)
M4	Pxx-EN1/EN2-12	0,10-0,15	0,10-0,20	0,10-0,30	20 (15-30)	30 (25-40)	30 (25-40)
M5	Pxx-EN1/EN2-12	0,10-0,15	0,10-0,20	0,10-0,30	20 (15-30)	30 (25-40)	30 (25-40)
K1	Pxx-EN1/EN2-12	0,10-0,20	0,10-0,30	0,10-0,30	-	90 (80-100)	-
K3	Pxx-EN1/EN2-12	0,10-0,20	0,10-0,30	0,10-0,30	-	90 (80-100)	-
K4	Pxx-EN1/EN2-12	0,10-0,20	0,10-0,30	0,10-0,30	-	70 (60-80)	-
K5	Pxx-EN1/EN2-12	0,10-0,20	0,10-0,30	0,10-0,30	-	70 (60-80)	-
N11	Pxx-EN1/EN2-12	0,10-0,30	0,20-0,50	0,10-0,30	65 (50-150)	90 (70-150)	-
S1	Pxx-EN1/EN2-12	0,10-0,15	0,10-0,20	0,10-0,30	-	25 (15-30)	-
S2	Pxx-EN1/EN2-12	0,10-0,15	0,10-0,20	0,10-0,30	-	25 (15-30)	-
S3	Pxx-EN1/EN2-12	0,10-0,15	0,10-0,20	0,10-0,30	-	25 (15-30)	-
PM1	Pxx-EN1/EN2-12	0,10-0,20	0,10-0,30	0,10-0,30	-	50 (25-70)	-
PM2	Pxx-EN1/EN2-12	0,10-0,20	0,10-0,30	0,10-0,30	-	50 (25-70)	-
PM3	Pxx-EN1/EN2-12	0,10-0,20	0,10-0,30	0,10-0,30	-	50 (25-70)	-

Cutting data – Pxx-EN3-00

SMG		a_p (Ø)		f	v_c	
		Ø < 9	Ø ≥ 9		CP20	CP15
P5	Pxx-EN3-00	0,10-0,15	0,10-0,20	0,10-0,30	40 (30-50)	-
P6	Pxx-EN3-00	0,10-0,15	0,10-0,20	0,10-0,30	40 (30-50)	-
P7	Pxx-EN3-00	0,10-0,15	0,10-0,20	0,10-0,30	40 (30-50)	-
K1	Pxx-EN3-00	0,10-0,20	0,10-0,30	0,10-0,30	90 (80-100)	120 (80-150)
K2	Pxx-EN3-00	0,10-0,20	0,10-0,30	0,10-0,30	35 (25-50)	50 (25-70)
K3	Pxx-EN3-00	0,10-0,20	0,10-0,30	0,10-0,30	90 (80-100)	120 (80-150)
K4	Pxx-EN3-00	0,10-0,20	0,10-0,30	0,10-0,30	70 (60-80)	90 (80-100)
K5	Pxx-EN3-00	0,10-0,20	0,10-0,30	0,10-0,30	70 (60-80)	90 (80-100)
K6	Pxx-EN3-00	0,10-0,20	0,10-0,30	0,10-0,30	90 (80-100)	120 (80-150)
K7	Pxx-EN3-00	0,10-0,20	0,10-0,30	0,10-0,30	90 (80-100)	120 (80-150)
PM1	Pxx-EN3-00	0,10-0,20	0,10-0,30	0,10-0,30	50 (25-70)	-
PM2	Pxx-EN3-00	0,10-0,20	0,10-0,30	0,10-0,30	50 (25-70)	-
PM3	Pxx-EN3-00	0,10-0,20	0,10-0,30	0,10-0,30	50 (25-70)	-

SMG = Seco material group

 a_p = mm

f = mm/rev

 v_c = m/min

All cutting data are start values

Cutting data – Pxx-EN3-06

SMG		a _p (Ø)		f	v _c		
		Ø < 9	Ø ≥ 9			CP20	CP15
P1	Pxx-EN3-06	0,10-0,15	0,10-0,20	0,10-0,30	40 (30-60)	105 (90-120)	120 (90-150)
P2	Pxx-EN3-06	0,10-0,15	0,10-0,20	0,10-0,30	40 (30-60)	105 (90-120)	120 (90-150)
P3	Pxx-EN3-06	0,10-0,15	0,10-0,20	0,10-0,30	40 (30-60)	105 (90-120)	120 (90-150)
P4	Pxx-EN3-06	0,10-0,15	0,10-0,20	0,10-0,30	35 (25-40)	60 (40-70)	80 (60-100)
P5	Pxx-EN3-06	0,10-0,15	0,10-0,20	0,10-0,30	35 (25-40)	60 (40-70)	80 (60-100)
P6	Pxx-EN3-06	0,10-0,15	0,10-0,20	0,10-0,30	35 (25-40)	60 (40-70)	80 (60-100)
P7	Pxx-EN3-06	0,10-0,15	0,10-0,20	0,10-0,30	35 (25-40)	60 (40-70)	80 (60-100)
P8	Pxx-EN3-06	0,10-0,15	0,10-0,20	0,10-0,30	30 (25-40)	50 (30-60)	60 (40-70)
P11	Pxx-EN3-06	0,10-0,15	0,10-0,20	0,10-0,30	30 (25-40)	50 (30-60)	60 (40-70)
P12	Pxx-EN3-06	0,10-0,15	0,10-0,20	0,10-0,30	25 (20-30)	40 (25-45)	45 (30-55)
M1	Pxx-EN3-06	0,10-0,15	0,10-0,20	0,10-0,30	-	-	35 (25-40)
M2	Pxx-EN3-06	0,10-0,15	0,10-0,20	0,10-0,30	-	-	35 (25-40)
M3	Pxx-EN3-06	0,10-0,15	0,10-0,20	0,10-0,30	-	-	35 (25-40)
M4	Pxx-EN3-06	0,10-0,15	0,10-0,20	0,10-0,30	-	-	30 (25-40)
M5	Pxx-EN3-06	0,10-0,15	0,10-0,20	0,10-0,30	-	-	30 (25-40)
K1	Pxx-EN3-06	0,10-0,20	0,10-0,30	0,10-0,30	-	90 (80-100)	120 (80-150)
K2	Pxx-EN3-06	0,10-0,20	0,10-0,30	0,10-0,30	-	35 (25-50)	50 (25-70)
K3	Pxx-EN3-06	0,10-0,20	0,10-0,30	0,10-0,30	-	90 (80-100)	120 (80-150)
K4	Pxx-EN3-06	0,10-0,20	0,10-0,30	0,10-0,30	-	70 (60-80)	90 (80-100)
K5	Pxx-EN3-06	0,10-0,20	0,10-0,30	0,10-0,30	-	70 (60-80)	90 (80-100)
K6	Pxx-EN3-06	0,10-0,20	0,10-0,30	0,10-0,30	-	90 (80-100)	120 (80-150)
K7	Pxx-EN3-06	0,10-0,20	0,10-0,30	0,10-0,30	-	90 (80-100)	120 (80-150)
PM1	Pxx-EN3-06	0,10-0,20	0,10-0,30	0,10-0,30	-	50 (25-70)	-
PM2	Pxx-EN3-06	0,10-0,20	0,10-0,30	0,10-0,30	-	50 (25-70)	-
PM3	Pxx-EN3-06	0,10-0,20	0,10-0,30	0,10-0,30	-	50 (25-70)	-

Cutting data – Pxx-EN3-12

SMG		a _p (Ø)		f	v _c		
		Ø < 9	Ø ≥ 9		H15	CP20	CP15
P1	Pxx-EN3-12	0,10-0,15	0,10-0,20	0,10-0,30	40 (30-60)	105 (90-120)	120 (90-150)
P2	Pxx-EN3-12	0,10-0,15	0,10-0,20	0,10-0,30	40 (30-60)	105 (90-120)	120 (90-150)
P3	Pxx-EN3-12	0,10-0,15	0,10-0,20	0,10-0,30	40 (30-60)	105 (90-120)	120 (90-150)
P4	Pxx-EN3-12	0,10-0,15	0,10-0,20	0,10-0,30	35 (25-40)	60 (40-70)	80 (60-100)
P5	Pxx-EN3-12	0,10-0,15	0,10-0,20	0,10-0,30	35 (25-40)	60 (40-70)	80 (60-100)
P6	Pxx-EN3-12	0,10-0,15	0,10-0,20	0,10-0,30	35 (25-40)	60 (40-70)	80 (60-100)
P7	Pxx-EN3-12	0,10-0,15	0,10-0,20	0,10-0,30	35 (25-40)	60 (40-70)	80 (60-100)
P8	Pxx-EN3-12	0,10-0,15	0,10-0,20	0,10-0,30	30 (25-40)	50 (30-60)	60 (40-70)
P11	Pxx-EN3-12	0,10-0,15	0,10-0,20	0,10-0,30	30 (25-40)	50 (30-60)	60 (40-70)
P12	Pxx-EN3-12	0,10-0,15	0,10-0,20	0,10-0,30	25 (20-30)	40 (25-45)	45 (30-55)
K1	Pxx-EN3-12	0,10-0,20	0,10-0,30	0,10-0,30	-	90 (80-100)	-
K3	Pxx-EN3-12	0,10-0,20	0,10-0,30	0,10-0,30	-	90 (80-100)	-
K4	Pxx-EN3-12	0,10-0,20	0,10-0,30	0,10-0,30	-	70 (60-80)	-
K5	Pxx-EN3-12	0,10-0,20	0,10-0,30	0,10-0,30	-	70 (60-80)	-
PM1	Pxx-EN3-12	0,10-0,20	0,10-0,30	0,10-0,30	-	50 (25-70)	-
PM2	Pxx-EN3-12	0,10-0,20	0,10-0,30	0,10-0,30	-	50 (25-70)	-
PM3	Pxx-EN3-12	0,10-0,20	0,10-0,30	0,10-0,30	-	50 (25-70)	-

SMG = Seco material group

a_p = mm

f = mm/rev

v_c = m/min

All cutting data are start values

Adjustment instructions

1

Loosen the two adjustment screws (7) by a 1/4 turn.

2

Loosen the two clamping screws (5).

3

Clean the blade seat thoroughly then, index the used blade (2) edge or replace it.

4

Firmly push the blade against the axial end stop and the adjustment balls (6).

5

Tighten the clamping screws carefully.
(Hold the key at its shortest end for correct torque).

6

Set the μm clock to zero using the cylindrical rear end of guiding pads (3).

Adjustment instructions

7



Set the rear end of the blade to a diameter so that a back taper of 0,01 mm/10 mm blade length is achieved (see figure 2).

8



Set the μm clock to zero using the cylindrical front end of guiding pads (3).

9



Set the front end of the blade to 0,02 mm or 0,015 mm above the guide pads (3) clock A, see figure 1.
Check again back taper value (steps 6 and 7) clock B.

10

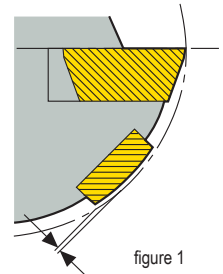
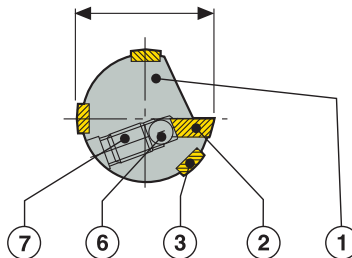
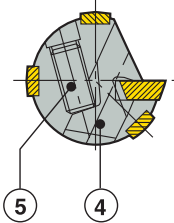

figure 1

Note: If the required diameter is exceeded during adjustment, start again from the beginning to eliminate backlash on adjustment screws.

0,015 mm ($\varnothing \leq 10$ mm)
0,020 mm ($\varnothing > 10$ mm)
clock A value for \varnothing setting

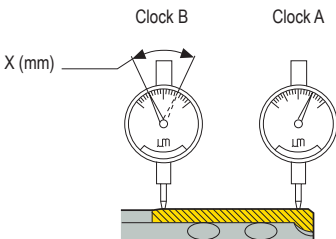
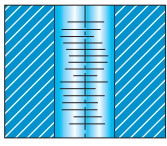
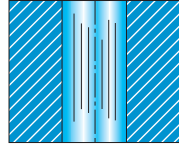
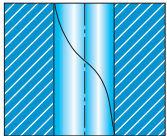
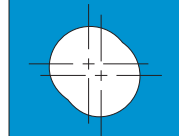
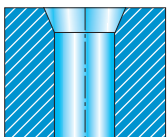
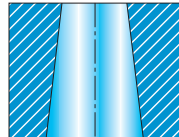
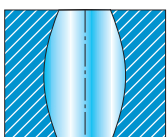
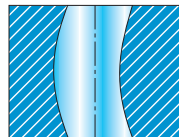
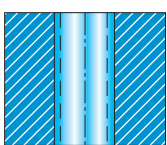
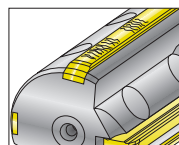

figure 2

Setting chart

Diameter range	Blade size	Front clock A	Rear clock B
5,900-6,874	P00	+15	+5
6,875-8,749	P0	+15	-5
8,750-10,000	P1	+15	-5
10,001-12,749	P1	+20	0
12,750-19,499	P2	+20	0
19,500-60,500	P4	+20	0

- Clock unit = 1 μm
- Front & rear clock values valid when set zero on adjacent pad
- Rear clock values calculated on back taper of 1 $\mu\text{m}/\text{mm}$ of blade

<p>Poor surface finish</p> <ul style="list-style-type: none"> • Check material allowances • Improve coolant conditions (outlet type, pressure, quality) • Reduce feed rate • Change blade (wrong lead geometry or wrong rake angle) • Check axial position of blade 	<p>Facets</p> <ul style="list-style-type: none"> • Improve centering (part/tool) • Increase back taper 
<p>Retraction marks</p> <ul style="list-style-type: none"> • Improve coolant conditions (outlet type, pressure, quality) • Improve centering (part/tool) • Increase back taper 	<p>Off center/Ovality</p> <ul style="list-style-type: none"> • Improve clamping (workpiece deformation) • Check material allowance • Improve centering (part/tool) • Check axial position of blade 
<p>Tapered entry</p> <ul style="list-style-type: none"> • Reduce feed rate • Improve centering (part/tool) • Check back taper • Reduce radial run-out 	<p>Tapered hole</p> <ul style="list-style-type: none"> • Improve centering (part/tool) • Check back taper 
<p>Deformed hole</p> <ul style="list-style-type: none"> • Improve clamping (workpiece deformation) 	<p>Curved hole</p> <ul style="list-style-type: none"> • Change blade (wrong lead geometry) • Check axial position of blade 
<p>Too large diameter</p> <ul style="list-style-type: none"> • Improve centering (part/tool) • Adjust diameter (too large) 	<p>Adhesion to pads</p> <ul style="list-style-type: none"> • Improve coolant conditions (outlet type, pressure, quality) • Adjust diameter (too small) 



Range overview

Precifix™	∅ Range	Reaming depth	Drill ∅ tolerance	Intermediate diameter	Surface finish (2)
	11,750–17,499 mm	~ 2–10 x D	IT 6–7	Yes, available through Custom design	R _a 0,4–0,8 μm
	17,500–31,499 mm	~ 2–8 x D	IT 6–7	Yes, available through Custom design	R _a 0,4–0,8 μm
	31,500–44,499 mm	~ 2–5 x D	IT 6–7	Yes, available through Custom design	R _a 0,4–0,8 μm
	44,500–60,500 mm	~ 2–3 x D	IT 6–7	Yes, available through Custom design	R _a 0,4–0,8 μm

Code key – Shanks

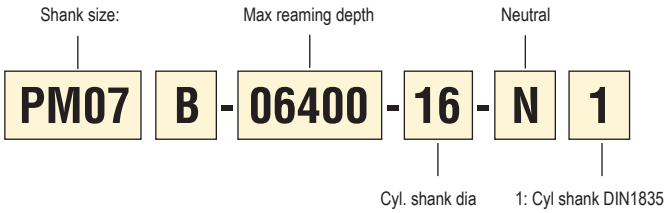

- ∅ 11,750-17,499 – PM07B shank size
- ∅ 17,500-31,499 – PM08B shank size
- ∅ 31,500-44,499 – PM15B shank size
- ∅ 44,500-60,500 – PM19B shank size



Code key – Heads

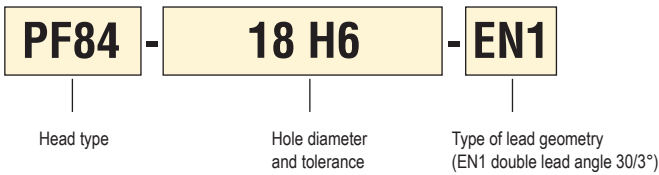

Code key – Heads – Intermediate diameter

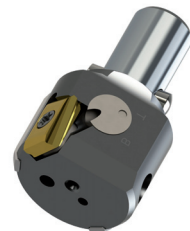
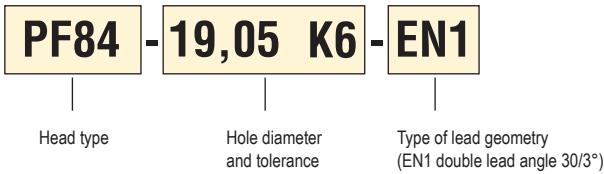

Code key – Inserts

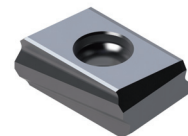
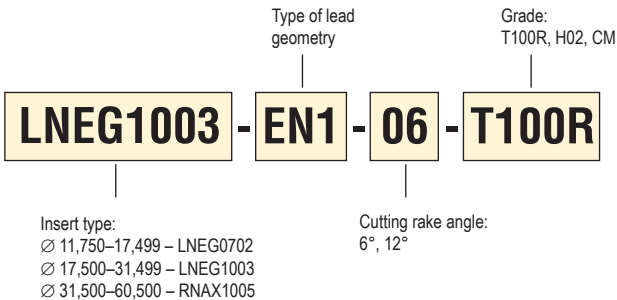

Set up – Run-out

Rotating tool

0,02 mm max

Max. run-out allowed is 0,02 mm.

Precision holder is recommended : Hydraulic chuck, D-type collet chuck, 5672 collet chuck or Shrinkfit.

Stationary tool

Use a Seco floating holder, see page 375-379.

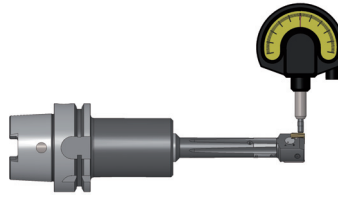

Coolant requirements

To reach maximum tool life and hole quality, the following coolant requirements should be observed.

Coolant through the tool is recommended. External coolant supply can be used if reaming depth < 2 x D.

Quality soluble oil with 40% minimum mineral oil. Neat oil recommended for stainless steel.

Concentration minimum 6–8%.

Filtration 30–50 µm.

Volume min 0,5 l/min/mm in tool diameter. (Ex: Reamer Ø 10, min volume is 5 l/min).

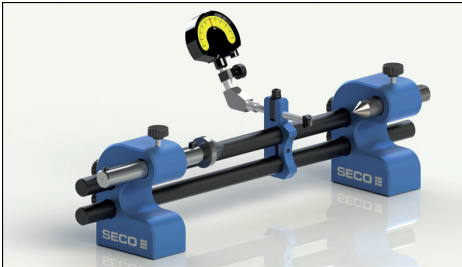

Setting fixture



SF-60200-C160: Part No. 02885395

- Horizontal stand
- First choice for Ø smaller than 60 mm
- 1 clock
- Maximum tool Ø: 60,5 mm
- Maximum tool length: 200 mm

Grades

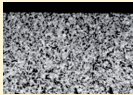
	<p>T100R</p>	<p>Coated PVD coated hard micrograin grade, suitable for most materials. (Ti,Al) N</p>
	<p>H02</p>	<p>Uncoated A tough micrograin grade for all materials. Suitable for fine-reaming operations thanks to very good edge sharpness.</p>
	<p>CM</p>	<p>Cermet A very high wear resistant grade. Intended for finishing operation on steels, in which strict demands are made on surface finish.</p>

Heads for Ø11,750-17,499 mm

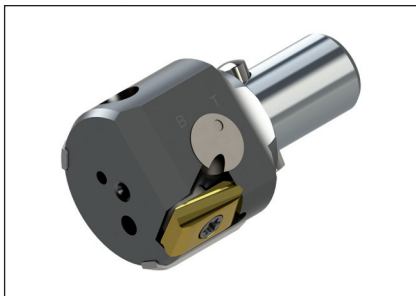

- For complete blade programme see page(s) 319
- For cutting data see page(s) 321

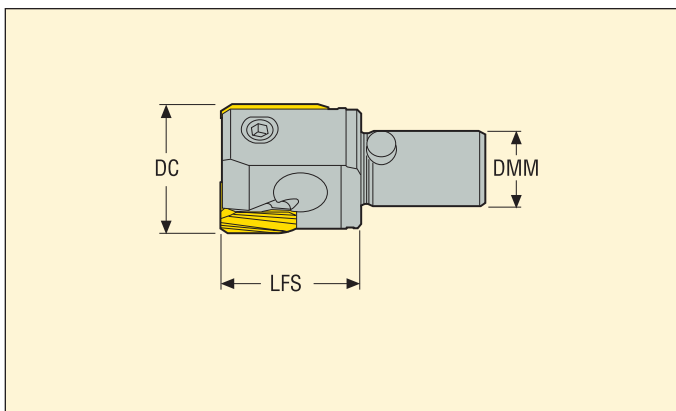

DC	Drill size*	Ordering and Product No.	Designation	Dimensions in mm		Blade size
				LFS	DMM	
12	11,8/11,908	02602321	PF84-12H6-EN1	13	7	LNEG0702-EN1...
13	12,8/12,9	02602325	PF84-13H6-EN1	13	7	LNEG0702-EN1...
14	13,8/13,891	02602327	PF84-14H6-EN1	13	7	LNEG0702-EN1...
15	14,8/14,9	02602331	PF84-15H6-EN1	13	7	LNEG0702-EN1...
16	15,8/15,9	02602333	PF84-16H6-EN1	13	7	LNEG0702-EN1...
17	16,8/16,9	02602334	PF84-17H6-EN1	13	7	LNEG0702-EN1...

Spare Parts

For Ø (mm)	Key	Insert screw	Cylindrical cartridge	Clamp screw	Clamp	Adjusting screw
11,750-17,499						
11,750-17,499	1.5SMS795	C01805-T06P	CARTCY4	C02506-T07P	CLW5	SH3030P

Accessories**

Torque key	Dynamo-metric key
T00-06P05	T00-07P05

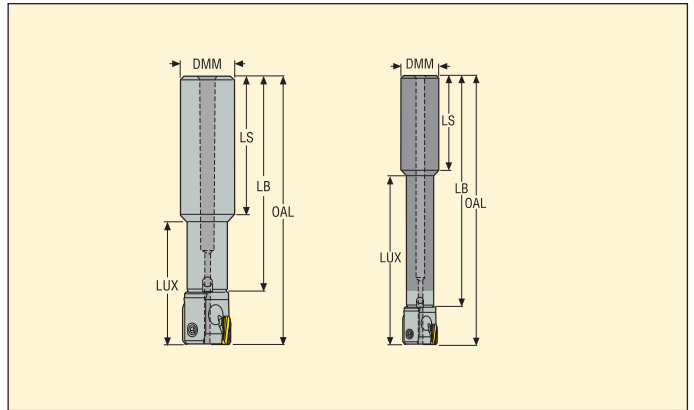

*For further information on which drill to use and how to use it see page(s) 9. **Accessories not included in delivery. When ordering intermediate diameters please state Ø and tolerance of hole to be reamed. **Ordering example:** PF84-12.700 ± 8 µm-EN1.

Shanks for $\varnothing 11,750-17,499$ mm



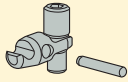

DC	Head	Tool holder material	Ordering and Product No.	Designation	Dimensions in mm				
					OAL	LB	LS	LUX	DMM
11,5-15,499	PF84	Steel	02503706	PM07B-03300-16N1	84	72	48	33	16

Spare Parts

For shank	Clamp kit	Clamp key
		
PM07B	PM07-CLKI	1.5SMS795

Accessories*

Torque key	Replacement blade
	
H00-1505	H00-1.5

*Accessories not included in delivery.

Heads for Ø17,500-24,499 mm

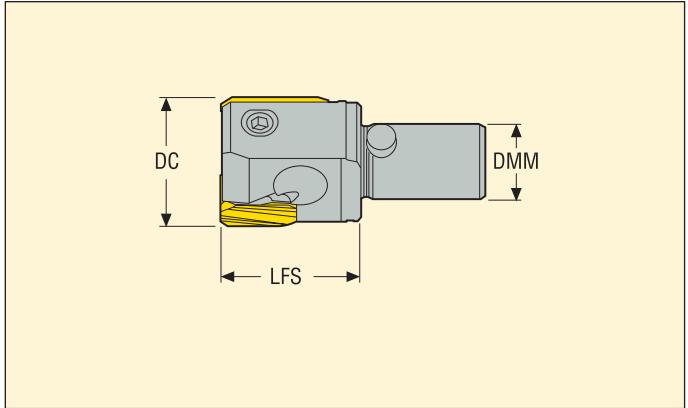
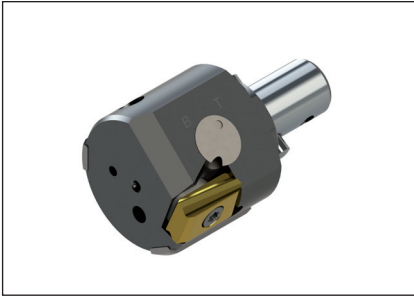

- For complete blade programme see page(s) 319
- For cutting data see page(s) 321

DC	Drill size*	Ordering and Product No.	Designation	Dimensions in mm		Blade size
				LFS	DMM	
18	17,8/17,9	02602335	PF84-18H6-EN1	20	8	LNEG1003-EN1...
19	18,8/18,9	02602336	PF84-19H6-EN1	20	8	LNEG1003-EN1...
20	19,8/19,9	02602337	PF84-20H6-EN1	20	8	LNEG1003-EN1...
21	20,8/20,9	02602338	PF84-21H6-EN1	20	8	LNEG1003-EN1...
22	21,8/21,9	02602339	PF84-22H6-EN1	20	8	LNEG1003-EN1...
23	22,8/22,9	02602347	PF84-23H6-EN1	20	8	LNEG1003-EN1...
24	23,813/23,9	02602348	PF84-24H6-EN1	20	8	LNEG1003-EN1...

Spare Parts

Accessories**

For Ø (mm)	Key	Insert screw	Cylindrical cartridge	Clamp screw	Clamp	Adjusting screw	Torque key	Dynamo-mentic key
17,500-24,499	2SMS795	C02506-T07P	CARTCY6	C03010-T09P	CLW7	SH4040P	T00-07P09	T00-09P09

*For further information on which drill to use and how to use it see page(s) 9. **Accessories not included in delivery. When ordering intermediate diameters please state Ø and tolerance of hole to be reamed. **Ordering example:** PF84-25.400 ± 18 µm-EN1.

Shanks for Ø17,500-24,499 mm

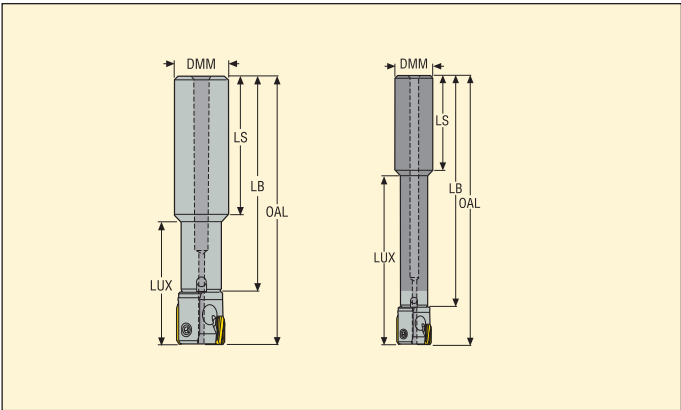
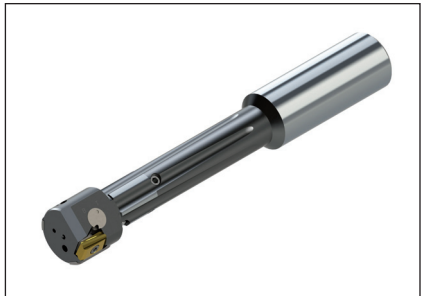

DC	Head	Tool holder material	Ordering and Product No.	Designation	Dimensions in mm				
					OAL	LB	LS	LUX	DMM
15,5-21,499	PF84	Steel	02546838	PM08B-03800-12N1	91	78	50	38	12
	PF84	Steel	02546839	PM08B-03800-16N1	91	78	50	38	16
	PF84	Steel	02503707	PM08B-03800-20N1	91	78	50	38	20
	PF84	Steel	02422905	PM08B-08200-20N1	135	122	50	82	20
	PF84	Steel	02503713	PM08B-14500-20N1	198	185	50	145	20

Spare Parts

Accessories*

For shank	Clamp kit	Clamp key	Torque key	Replacement blade
PM08B	PM08-CLKI	2SMS795	H00-2009	H00-2.0

*Accessories not included in delivery.

Heads for \varnothing 24,500-31,499 mm

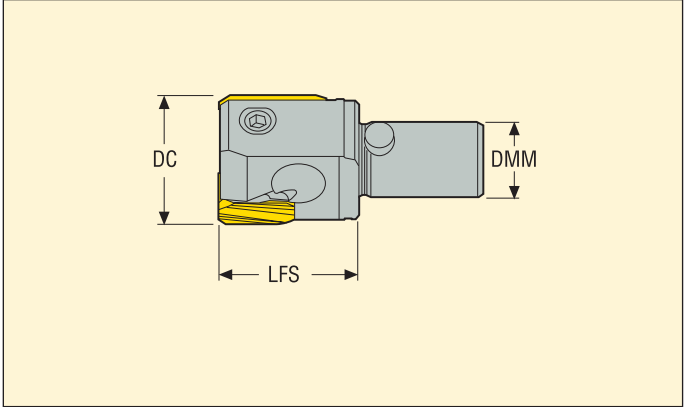
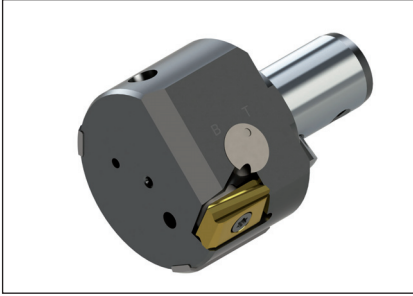

- For complete blade programme see page(s) 319
- For cutting data see page(s) 321

DC	Drill size*	Ordering and Product No.	Designation	Dimensions in mm		Blade size
				LFS	DMM	
25	24,8/24,9	02602349	PF84-25H6-EN1	20	11	LNEG1003-EN1...
26	25,8/25,9	02602350	PF84-26H6-EN1	20	11	LNEG1003-EN1...
27	26,8/26,9	02602351	PF84-27H6-EN1	20	11	LNEG1003-EN1...
28	27,8/27,9	02602352	PF84-28H6-EN1	20	11	LNEG1003-EN1...
29	28,8/28,9	02602353	PF84-29H6-EN1	20	11	LNEG1003-EN1...
30	29,8/29,9	02602354	PF84-30H6-EN1	20	11	LNEG1003-EN1...
31	30,8/30,9	02602355	PF84-31H6-EN1	20	11	LNEG1003-EN1...

Spare Parts

Accessories**

For \varnothing (mm)	Key	Insert screw	Cylindrical cartridge	Clamp screw	Clamp	Adjusting screw	Torque key	Dynamo-metric key
24,500-31,499								

*For further information on which drill to use and how to use it see page(s) 9. **Accessories not included in delivery. When ordering intermediate diameters please state \varnothing and tolerance of hole to be reamed. Ordering example: PF84-25.400 \pm 18 μ m-EN1.

Shanks for Ø24,500-31,499 mm

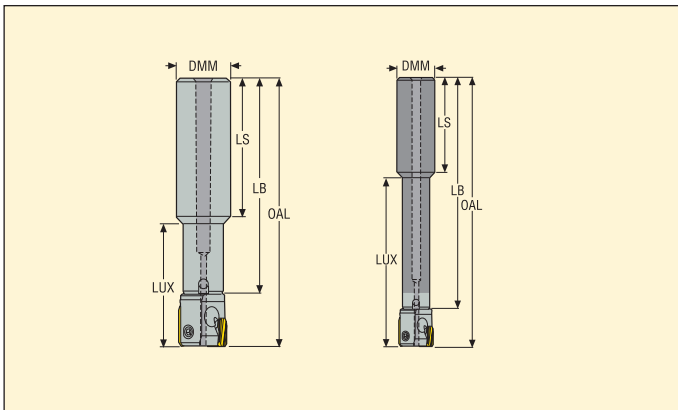

DC	Head	Tool holder material	Ordering and Product No.	Designation	Dimensions in mm				
					OAL	LB	LS	LUX	DMM
21,5-26,499	PF84	Steel	02503708	PM11B-04800-25N1	107	91	56	48	25
	PF84	Steel	02422906	PM11B-10600-25N1	165	149	56	106	25
	PF84	Steel	02503714	PM11B-17000-25N1	229	213	56	170	25

Spare Parts

Accessories*

For shank	Clamp kit	Clamp key
PM11B	PM11-CLKI	2.5SMS795

Torque key	Replacement blade
H00-2512	H00-2.5

*Accessories not included in delivery.

Heads for $\varnothing 31,500-44,499$ mm

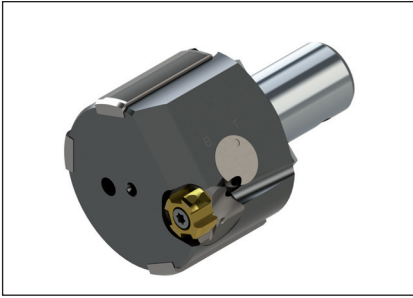

- For complete blade programme see page(s) 319
- For cutting data see page(s) 321

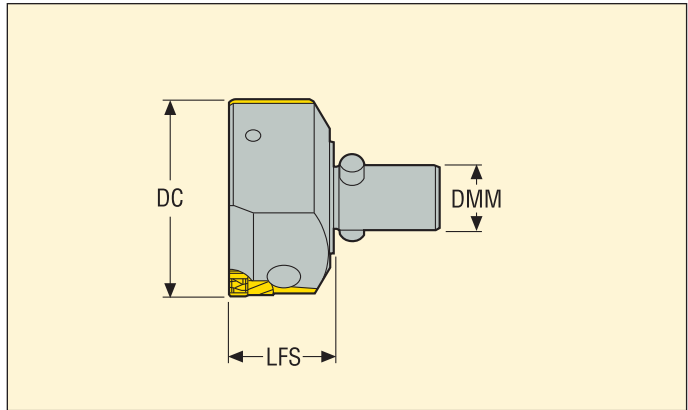

DC	Drill size*	Ordering and Product No.	Designation	Dimensions in mm		Blade size
				LFS	DMM	
32	31,70/31,80	02602356	PF84-32H6-EN1	31	15	RNAX1005-EN1...
33	32,70/32,80	02602357	PF84-33H6-EN1	31	15	RNAX1005-EN1...
34	33,70/33,80	02602359	PF84-34H6-EN1	31	15	RNAX1005-EN1...
36	35,70/35,80	02602361	PF84-36H6-EN1	31	15	RNAX1005-EN1...
38	37,70/37,80	02602363	PF84-38H6-EN1	31	15	RNAX1005-EN1...
39	38,70/38,80	02602365	PF84-39H6-EN1	31	15	RNAX1005-EN1...
40	39,70/39,80	02602366	PF84-40H6-EN1	31	15	RNAX1005-EN1...
42	41,70/41,80	02602367	PF84-42H6-EN1	31	15	RNAX1005-EN1...
44	43,70/43,80	02602368	PF84-44H6-EN1	31	15	RNAX1005-EN1...
41	40,70/40,80	02603248	PF84-41H6-EN1	31	15	RNAX1005-EN1...
43	42,70/42,80	02603249	PF84-43H6-EN1	31	15	RNAX1005-EN1...

Spare Parts

Accessories**

For \varnothing (mm)	Key	Insert screw	Cylindrical cartridge	Clamp screw	Clamp	Adjusting screw	Torque key	Dynamo-mentic key
31,500-44,499								
	2SMS795	C03010-T09P	CARTCY12	C04013-T15P	CLW10	SH4080P	T00-09P20	T00-15P20

*For further information on which drill to use and how to use it see page(s) 9. **Accessories not included in delivery. When ordering intermediate diameters please state \varnothing and tolerance of hole to be reamed. **Ordering example:** PF84-31,500 K6-EN1.

Shanks for $\varnothing 31,500-44,499$ mm

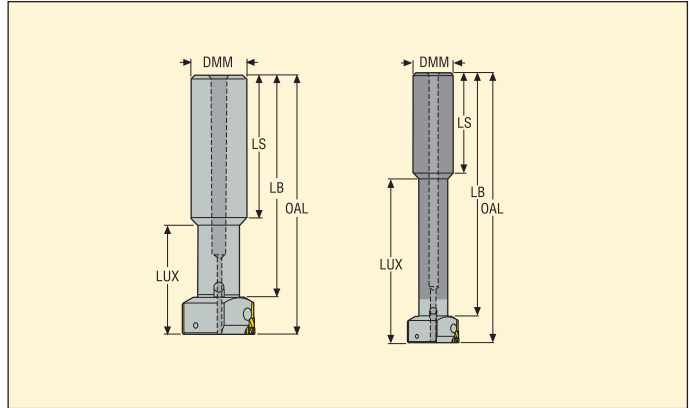

DC	Head	Tool holder material	Ordering and Product No.	Designation	Dimensions in mm				
					OAL	LB	LS	LUX	DMM
26,5-38,499	PF84	Steel	02503709	PM15B-06300-25N1	121	101	56	63	25
	PF84	Steel	02422907	PM15B-12700-25N1	185	165	56	127	25
	PF84	Steel	02496516	PM15B-17000-25N1	229	209	56	170	25

Spare Parts

For shank	Clamp kit	Clamp key
PM15B	PM15-CLKI	3SMS795

Accessories*

Torque key	Replacement blade
H00-3020	H00-3.0

*Accessories not included in delivery.

Heads for Ø44,500-60,500 mm

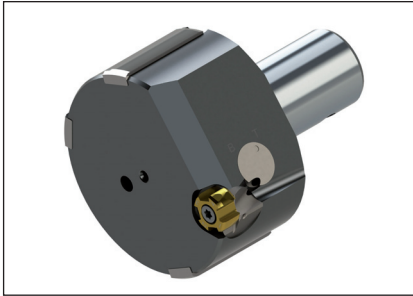

- For complete blade programme see page(s) 319
- For cutting data see page(s) 321

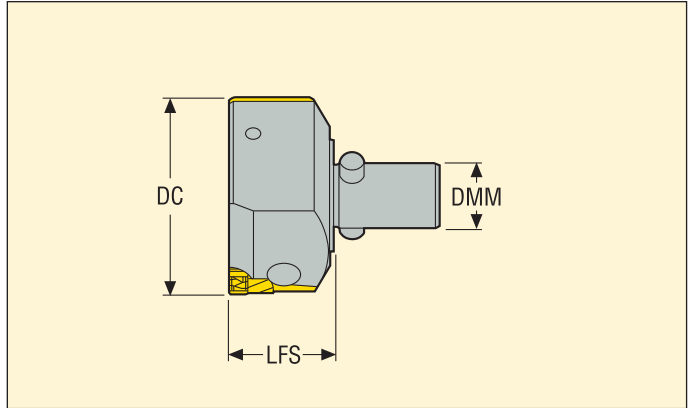

DC	Drill size*	Ordering and Product No.	Designation	Dimensions in mm		Blade size
				LFS	DMM	
48	47,70/47,80	02602370	PF84-48H6-EN1	31	19	RNAX1005-EN1...
50	49,70/49,80	02602371	PF84-50H6-EN1	31	19	RNAX1005-EN1...
52	51,70/51,80	02602372	PF84-52H6-EN1	31	19	RNAX1005-EN1...
54	53,70/53,80	02602374	PF84-54H6-EN1	31	19	RNAX1005-EN1...
58	57,70/57,80	02602377	PF84-58H6-EN1	31	19	RNAX1005-EN1...
60	59,70/59,80	02602380	PF84-60H6-EN1	31	19	RNAX1005-EN1...
49	48,70/48,80	02603253	PF84-49H6-EN1	31	19	RNAX1005-EN1...
51	50,70/50,80	02603258	PF84-51H6-EN1	31	19	RNAX1005-EN1...
53	52,70/52,80	02603259	PF84-53H6-EN1	31	19	RNAX1005-EN1...
55	54,70/54,80	02603261	PF84-55H6-EN1	31	19	RNAX1005-EN1...
56	55,70/55,80	02603263	PF84-56H6-EN1	31	19	RNAX1005-EN1...
57	56,70/56,80	02603264	PF84-57H6-EN1	31	19	RNAX1005-EN1...
59	58,70/58,80	02603265	PF84-59H6-EN1	31	19	RNAX1005-EN1...
45	44,70/44,80	02603483	PF84-45H6-EN1	31	19	RNAX1005-EN1...
46	45,70/45,80	02603495	PF84-46H6-EN1	31	19	RNAX1005-EN1...
47	46,70/46,80	02603498	PF84-47H6-EN1	31	19	RNAX1005-EN1...

Spare Parts

Accessories**

For Ø (mm)	Key	Insert screw	Cylindrical cartridge	Clamp screw	Clamp	Adjusting screw	Torque key	Dynamo-mentic key
44,500-60,500	2SMS795	C03010-T09P	CARTCY12	C04013-T15P	CLW10	SH4080P	T00-09P20	T00-15P20

*For further information on which drill to use and how to use it see page(s) 9. **Accessories not included in delivery. When ordering intermediate diameters please state Ø and tolerance of hole to be reamed. **Ordering example:** PF84-51,250 M7-EN1.

Shanks for Ø44,500-60,500 mm

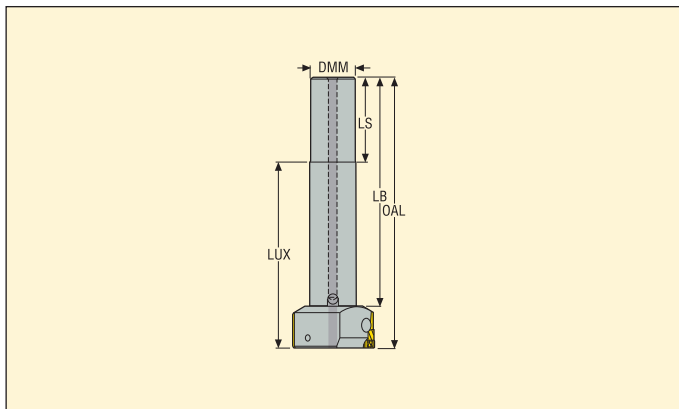
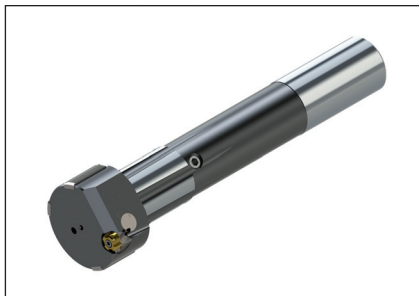

DC	Head	Tool holder material	Ordering and Product No.	Designation	Dimensions in mm				
					OAL	LB	LS	LUX	DMM
38,5-60,5	PF84	Steel	02503710	PM19B-08800-32N1	149	127	61	88	32
	PF84	Steel	02503711	PM19B-14700-32N1	208	186	61	147	32

Spare Parts

Accessories*

For shank	Clamp kit	Clamp key	Torque key	Replacement blade
PM19B	PM19-CLKI	4SMS795	H00-4030	H00-4.0

*Accessories not included in delivery.

Heads for $\varnothing 11,750-60,500$ mm – Intermediate diameter

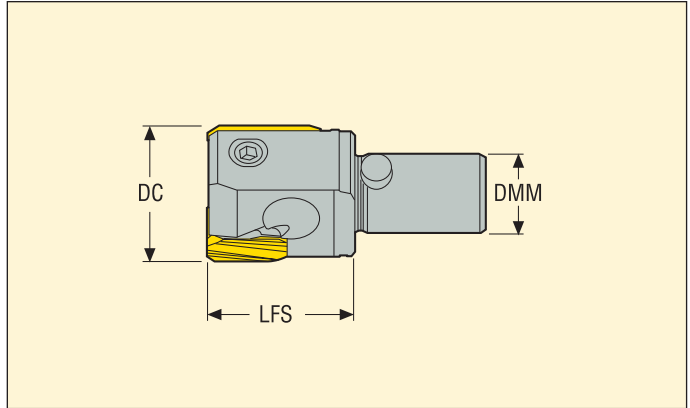
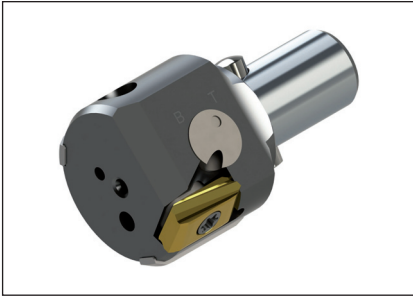

- For complete blade programme see page(s) 319
- For cutting data see page(s) 321

DC	Designation	Dimensions in mm		Blade size
		LFS	DMM	
11,750-17,499	PF84-xx.xxx-EN1	13	7	LNEG0702EN1...
17,500-24,499	PF84-xx.xxx-EN1	20	8	LNEG1003EN1...
24,500-31,499	PF84-xx.xxx-EN1	20	11	LNEG1003EN1...
31,500-44,499	PF84-xx.xxx-EN1	31	15	RNAX1005...
44,500-60,500	PF84-xx.xxx-EN1	31	19	RNAX1005...

Spare Parts

For \varnothing (mm)	Insert screw	Torque key**	Torque value	Cylindrical cartridge	Clamp	Clamp screw	Torque key**	Torque value	Setting screw	Setting key
11,750-17,499	C01805-T06P	T00-06P05	0,5 Nm	CARTCY4	CLW5	C02506-T07P	T00-07P05	0,5 Nm	SH3030P	1.5 SMS795
17,500-24,499	C02506-T07P	T00-07P09	0,9 Nm	CARTCY6	CLW7	C03010-T09P	T00-09P09	0,9 Nm	SH4040P	2SMS795
24,500-31,499	C02506-T07P	T00-07P09	0,9 Nm	CARTCY6	CLW7	C03010-T09P	T00-09P09	0,9 Nm	SH4040P	2SMS795
31,500-44,499	C03010-T07P	T00-09P20	2,0 Nm	CARTCY12	CLW10	C04013-T15P	T00-15P20	2,0 Nm	SH4080P	2SMS795
44,500-60,500	C03010-T07P	T00-09P20	2,0 Nm	CARTCY12	CLW10	C04013-T15P	T00-15P20	2,0 Nm	SH4080P	2SMS795

*For further information on which drill to use and how to use it see page(s) 9. **To be ordered separately.
When ordering intermediate diameters please state \varnothing and tolerance of hole to be reamed. **Ordering example:** PF84-12.700 ± 8 μm-EN1.

LNEG

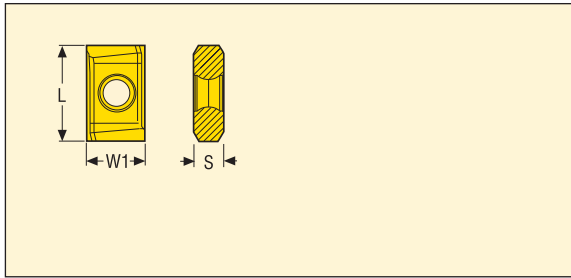

Size	Dimensions in mm		
	L	W1	S
07	7,0	4,2	2,25
10	10,0	6,35	3,5

Inserts	Designation	Grades		
		T100R	H02	CM
LNEG-EN1	LNEG0702-EN1-06	02729110	02729108	02904272
	LNEG0702-EN1-12	02729105	02729084	<input type="checkbox"/>
	LNEG1003-EN1-06	02729116	02729115	02904271
	LNEG1003-EN1-12	02729114	02729113	<input type="checkbox"/>

Product number = Stock standard Non stock standard. Subject to change refer to current price- and stock-list.

RNAX

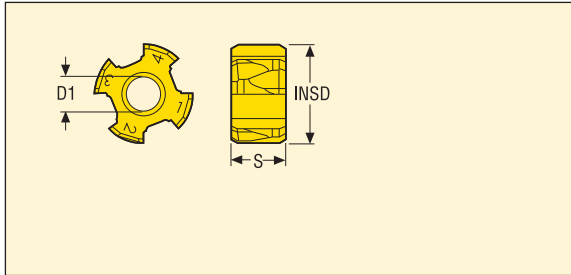

Size	Dimensions in mm		
	INSD	S	D1
10	10,0	5,5	3,5

Inserts	Designation	Grades		
		T100R	H02	CM
RNAX-EN1	RNAX1005-EN1-06	02602440	02602430	02602434
	RNAX1005-EN1-12	02602448	02602431	02602449

■ Stock standard
Subject to change refer to current price- and stock-list

Custom design – No waiting for quotations – Short delivery time

Custom Design is also available for Precifix reamers and tool holders.

You can now quote for your own intermediate \varnothing reamer and tailor made Precifix tool holder using the Seco Custom Design software.

Easy to use concept: Just indicate component min/max \varnothing or use ISO tolerance system available in the software.

Precifix head designation is created automatically.

Custom Design gives you a number of advantages:

- No waiting for quotations! Price and delivery time available instantly!
- Directly visualises your needs. No risk of misunderstandings
- Short delivery time



CUSTOM DESIGN

Version 1.7.9.6

Reaming >> Precifix >> Precifix shanks
Test mode (Exit) Seco mode Feedback

Back
Start Page
Login
English

 [Print this page](#)

Step 1: Tool Specification
Step 2: Request for Quotation

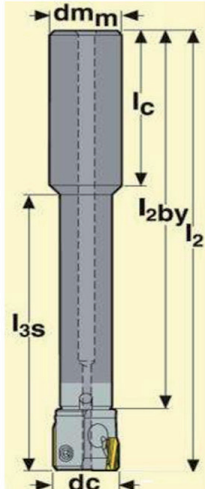

Inch:

	Min	Max	
Work piece	A Through hole		<input type="button" value="v"/>
Size	dc 11.500 - 17.499		<input type="button" value="v"/>
dmm			<input type="text" value="10"/>
chamfer			<input type="text" value="3"/>
l3s	31	172	<input type="text" value="150"/>
l2			<input type="text" value="193"/>
l2by			<input type="text" value="180"/>
lc			<input type="text" value="40"/>

Designation
PM07B-14900-10N1

Delivery Time

Quantity:

Min Quantity: 1

Please contact your local Seco representative for more information.

320

Cutting data – LNEG...-EN1

SMG		a _p (Ø)	f	v _c		
				H02	T100R	CM
P1	LNEG...-EN1	0,1-0,2	0,1-0,3	40 (30-60)	100 (80-120)	150 (120-250)
P2	LNEG...-EN1	0,1-0,2	0,1-0,3	40 (30-60)	100 (80-120)	150 (120-250)
P3	LNEG...-EN1	0,1-0,2	0,1-0,3	40 (30-60)	100 (80-120)	150 (120-250)
P4	LNEG...-EN1	0,1-0,2	0,1-0,3	30 (20-40)	60 (40-80)	80 (60-150)
P5	LNEG...-EN1	0,1-0,2	0,1-0,3	30 (20-40)	60 (40-80)	80 (60-150)
P6	LNEG...-EN1	0,1-0,2	0,1-0,3	30 (20-40)	60 (40-80)	80 (60-150)
P7	LNEG...-EN1	0,1-0,2	0,1-0,3	30 (20-40)	60 (40-80)	80 (60-150)
P8	LNEG...-EN1	0,1-0,2	0,1-0,3	30 (20-40)	40 (30-80)	-
P11	LNEG...-EN1	0,1-0,2	0,1-0,3	30 (20-40)	40 (30-80)	-
P12	LNEG...-EN1	0,1-0,2	0,1-0,3	25 (15-30)	30 (25-65)	-
M1	LNEG...-EN1	0,08-0,15	0,1-0,2	25 (20-30)	30 (20-40)	-
M2	LNEG...-EN1	0,08-0,15	0,1-0,2	25 (20-30)	30 (20-40)	-
M3	LNEG...-EN1	0,08-0,15	0,1-0,2	25 (20-30)	30 (20-40)	-
M4	LNEG...-EN1	0,08-0,15	0,1-0,2	20 (15-30)	25 (20-30)	-
M5	LNEG...-EN1	0,08-0,15	0,1-0,2	20 (15-30)	25 (20-30)	-
K1	LNEG...-EN1	0,20-0,50	0,1-0,3	-	90 (70-120)	-
K2	LNEG...-EN1	0,20-0,50	0,1-0,3	-	35 (50-80)	-
K3	LNEG...-EN1	0,20-0,50	0,1-0,3	-	90 (70-120)	-
K4	LNEG...-EN1	0,20-0,50	0,1-0,3	-	70 (50-100)	100 (60-120)
K5	LNEG...-EN1	0,20-0,50	0,1-0,3	-	70 (50-100)	100 (60-120)
K6	LNEG...-EN1	0,20-0,50	0,1-0,3	-	90 (70-120)	-
K7	LNEG...-EN1	0,20-0,50	0,1-0,3	-	90 (70-120)	-
S11	LNEG...-EN1	0,08-0,15	0,1-0,2	15 (10-25)	-	-
S12	LNEG...-EN1	0,08-0,15	0,1-0,2	15 (10-25)	-	-
S13	LNEG...-EN1	0,08-0,15	0,1-0,2	15 (10-25)	-	-

Cutting data – RNAX...-EN1

SMG		a _p (Ø)	f	v _c		
				H02	T100R	CM
P1	RNAX...-EN1	0,1-0,2	0,1-0,3	40 (30-60)	100 (80-120)	150 (120-250)
P2	RNAX...-EN1	0,1-0,2	0,1-0,3	40 (30-60)	100 (80-120)	150 (120-250)
P3	RNAX...-EN1	0,1-0,2	0,1-0,3	40 (30-60)	100 (80-120)	150 (120-250)
P4	RNAX...-EN1	0,1-0,2	0,1-0,3	30 (20-40)	60 (40-80)	80 (60-150)
P5	RNAX...-EN1	0,1-0,2	0,1-0,3	30 (20-40)	60 (40-80)	80 (60-150)
P6	RNAX...-EN1	0,1-0,2	0,1-0,3	30 (20-40)	60 (40-80)	80 (60-150)
P7	RNAX...-EN1	0,1-0,2	0,1-0,3	30 (20-40)	60 (40-80)	80 (60-150)
P8	RNAX...-EN1	0,1-0,2	0,1-0,3	30 (20-40)	40 (30-80)	-
P11	RNAX...-EN1	0,1-0,2	0,1-0,3	30 (20-40)	40 (30-80)	-
P12	RNAX...-EN1	0,1-0,2	0,1-0,3	25 (15-30)	30 (25-65)	-
K1	RNAX...-EN1	0,20-0,50	0,1-0,3	-	90 (70-120)	-
K2	RNAX...-EN1	0,20-0,50	0,1-0,3	-	35 (50-80)	-
K3	RNAX...-EN1	0,20-0,50	0,1-0,3	-	90 (70-120)	-
K4	RNAX...-EN1	0,20-0,50	0,1-0,3	-	70 (50-100)	100 (60-120)
K5	RNAX...-EN1	0,20-0,50	0,1-0,3	-	70 (50-100)	100 (60-120)
K6	RNAX...-EN1	0,20-0,50	0,1-0,3	-	90 (70-120)	-
K7	RNAX...-EN1	0,20-0,50	0,1-0,3	-	90 (70-120)	-

SMG = Seco material group





a_p = mm

f = mm/rev

v_c = m/min

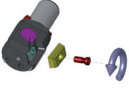
All cutting data are start values

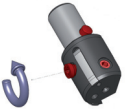
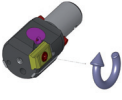
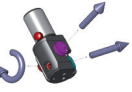
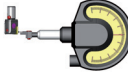
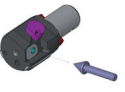
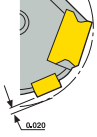
Adjustment instructions

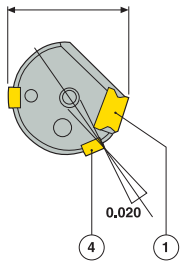
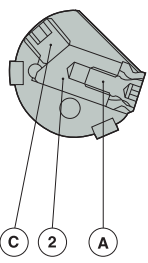
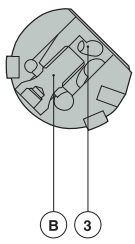
<p>1 Unscrew blade locking screw 'A' and remove blade '1'.</p> 	<p>6 Tighten clamping screw 'B'.</p> 	
<p>2 Loosen clamping screw 'B' 2-3 revolutions.</p> 	<p>7 Clean the blade seat thoroughly then, index the used blade '1' or replace it.</p> 	
<p>3 Tighten adjusting screw 'C' to push adjustable cartridge '2' and unlock cylindrical clamp '3'.</p> 	<p>8 Place clock at front end of blade and set to zero using the cylindrical guiding pads '4'.</p> 	
<p>4 Push adjustable cartridge '2' fully back in its seat pocket.</p> 	<p>9 Set the insert to 0,02 mm above guiding pad '4'.</p> 	
<p>5 Put cylindrical clamp '3' back in position against adjustable cartridge '2'.</p> 		
		
<p>1 = Insert 2 = Adjustable cartridge 3 = Cylindrical clamp 4 = Guiding pads</p> <p>A = Insert locking screw B = Clamping screw C = Adjusting screw</p>		



Note: If the required diameter is exceeded during adjustment, start again from the beginning to eliminate backlash on adjustment screws.

Coolant setting instructions

<p>1 Unscrew blade locking screw 'A' and remove blade '1'.</p>	<p>4 Push adjustable cartridge '2' fully back in its seat pocket.</p>
<p>2 Loosen clamping screw 'B' 2-3 revolutions.</p>	<p>5 Index and put cylindrical clamp '3' back in position against adjustable cartridge '2': Mark on clamp facing 'T' index – Coolant outlet set for THROUGH holes. Mark on clamp facing 'B' index – Coolant outlet set for BLIND holes.</p>
<p>3 Tighten adjusting screw 'C' to push adjustable cartridge '2' and unlock cylindrical clamp '3'.</p>	<p>6 Tighten clamping screw 'B'.</p>

<p>7 Proceed to blade setting - Adjustment instructions see previous page.</p>		
<p>1 = Insert 2 = Adjustable cartridge 3 = Cylindrical clamp 4 = Guiding pads</p> <p>A = Insert locking screw B = Clamping screw C = Adjusting screw</p>		

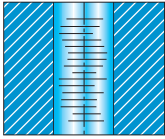
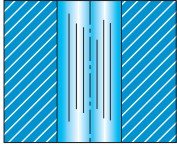
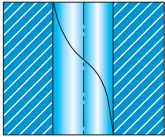
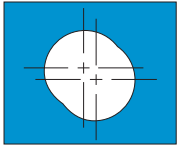
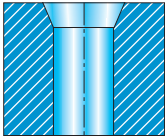
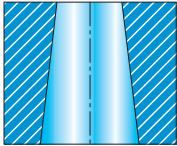
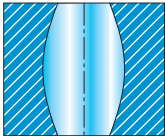
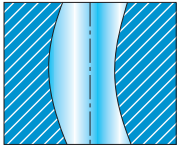
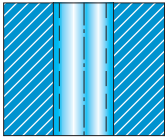
Troubleshooting

<p>Poor surface finish</p> <ul style="list-style-type: none"> • Check material allowance • Improve coolant conditions (outlet type, pressure, quality) • Reduce feed rate • Change blade (wrong lead geometry or wrong rake angles) • Check axial position of blade 	<p>Facets</p> <ul style="list-style-type: none"> • Improve centering (part/tool) 
<p>Retraction marks</p> <ul style="list-style-type: none"> • Improve coolant conditions (outlet type, pressure, quality) • Improve centering (part/tool) 	<p>Off center/Ovality</p> <ul style="list-style-type: none"> • Improve clamping (workpiece deformation) • Check material allowance • Improve centering (part/tool) • Check axial position of blade 
<p>Tapered entry</p> <ul style="list-style-type: none"> • Reduce feed rate • Improve centering (part/tool) • Reduce radial run-out 	<p>Tapered hole</p> <ul style="list-style-type: none"> • Improve centering (part/tool) 
<p>Deformed hole</p> <ul style="list-style-type: none"> • Improve clamping (workpiece deformation) 	<p>Curved hole</p> <ul style="list-style-type: none"> • Change blade (wrong lead geometry) • Check axial position of blade 
<p>Too large diameter</p> <ul style="list-style-type: none"> • Improve centering (part/tool) • Adjust diameter (too large) 	<p>Adhesion to pads</p> <ul style="list-style-type: none"> • Improve coolant conditions (outlet type, pressure, quality) • Adjust diameter (too small) 



Range overview

Xfix™	∅ Range	Reaming depth	Drill ∅ tolerance	Intermediate diameter	Surface finish (2)
	39,500-154,500 mm	2,5–6,5 x D	IT 6	Yes, available through Custom design	R _a 0,8–1,2 μm

Xfix™ is a specially developed Seco Reaming programme, dedicated for large ∅ 39,5 to 154,5 mm. Design includes adjustable and indexable inserts to achieve IT 6 accurate tolerance, as well as a built in adjustable run-out adapter to guarantee component quality. Multi-teeth construction and patented pre-loaded guiding pads offering maximum stability and productivity for large ∅ reaming operations.

Feature details

- 4 or 8 cutting edges for optimisation in all materials
- Stable clamping system
- Easy adjustment with 1 adjusting screw for easy setting
- Grade and geometry choice for different applications

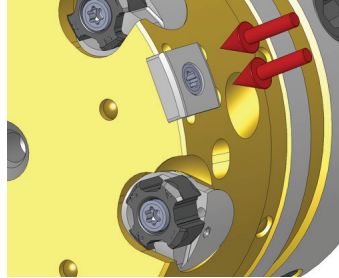
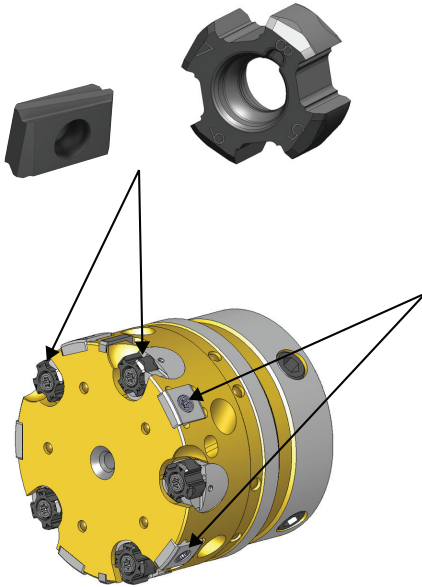

- Patented pre-loaded guiding pads system for application stability
- Pads lubrication for performance and safety

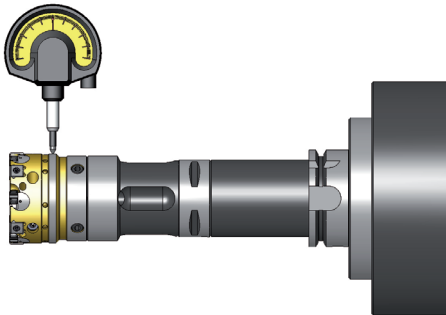

- Integrated adjustable adapter for perfect run-out control

- Shanks and extension programme from Seco Tooling Systems catalogue offer maximum modular

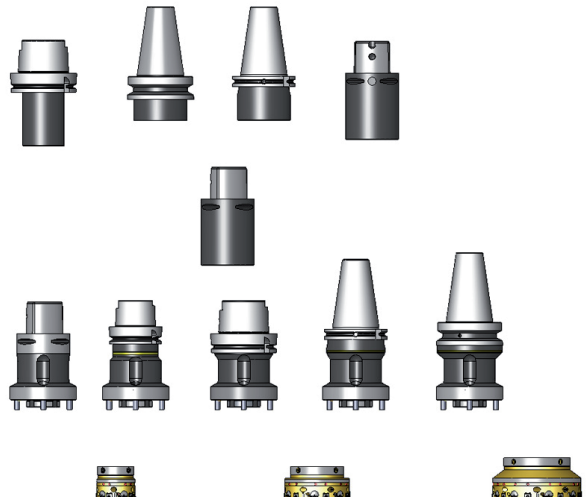

Code key – Adapters

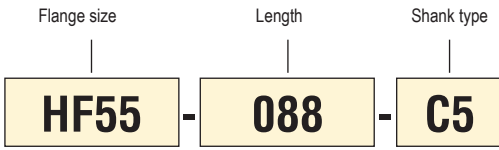

Code key – Standard heads

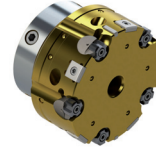
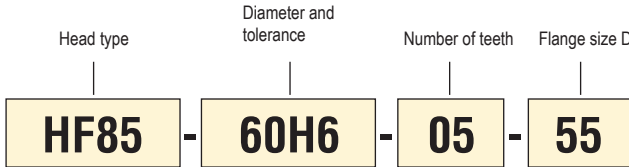

Code key – Heads Intermediate

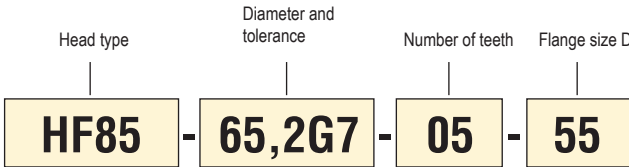

Head type information :

- HF85 , through bore, short chipping material
- HF85B, blind bore, short chipping material
- HF86, through bore , all material
- HF86B, blind bore, all material

Code key – Inserts

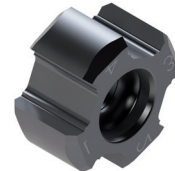
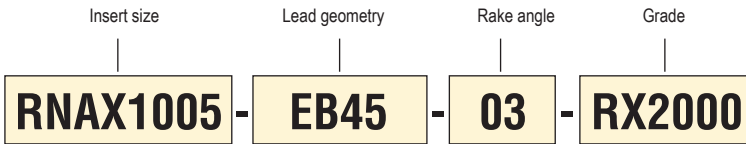

RNAX insert for HF85 & HF 85B Xfix heads

Code key – Inserts

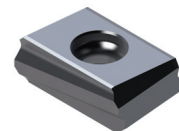
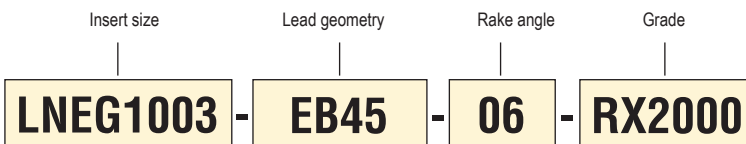

LNEG inserts for HF86 & HF86B Xfix heads

RNAX

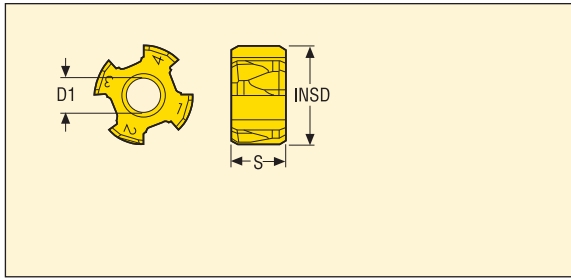

Size	Dimensions in mm		
	INSD	S	D1
10	10,0	5,5	3,5

Inserts	Designation	Grades			Rate angle
		RX1500	RX2000		
RNAX					
	RNAX1005-EB1570-03	02687601	02687603	3°	
	RNAX1005-EB45-03	02687600	02688608	3°	
	RNAX1005-EB845-03	02687593	02688606	3°	

■ Stock standard
 Subject to change refer to current price- and stock-list

LNEG

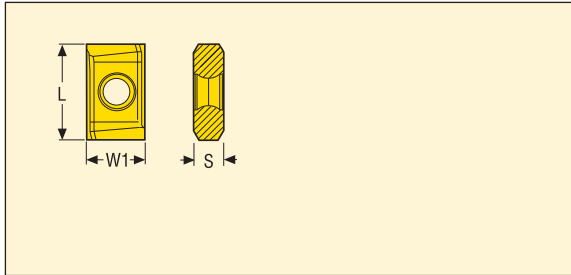



Size	Dimensions in mm		
	L	W1	S
10	10,0	6,35	3,5

Inserts	Designation	Grades			Rate angle
		RX1500	RX2000	CF	
LNEG					
	LNEG1003-EB45-03		02781311		3°
	LNEG1003-EB45-06	02904277	02781313	02904276	6°
	LNEG1003-EB845-03		02781314		3°
	LNEG1003-EB845-06		02781315		6°

■ Stock standard
 Subject to change refer to current price- and stock-list

Grades

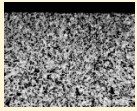
	RX1500	Coated Cermet A wear resistant coated grade for performance optimization in steel and cast iron.
	RX2000	Coated High performance coated grade suitable for all materials.
	CF	Cermet A wear resistant grade for performance optimization in steel.

Applications

Lead geometry - EB45

Chip control +++
Surface Finish + (R_a 1,2 - 2 μ m)
First choice geometry

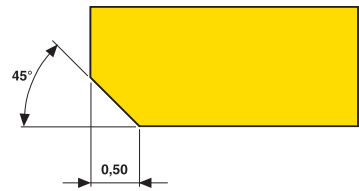

Lead geometry - EB845

Chip control ++
Surface finish+++ (R_a 0,4 - 1,2 μ m)

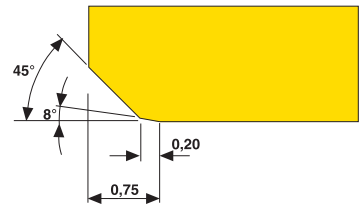

Lead geometry - EB1570

Chip control ++
Surface finish ++ (R_a 0,8 - 1,6 μ m)
Stability for long reach application +++

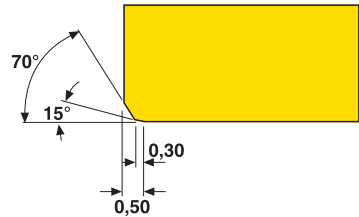

Heads for RNAX inserts, through bore \varnothing 39,5-59,499 mm

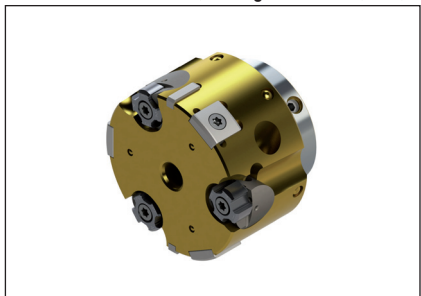

• For inserts, grades and geometries see page(s) 329-330

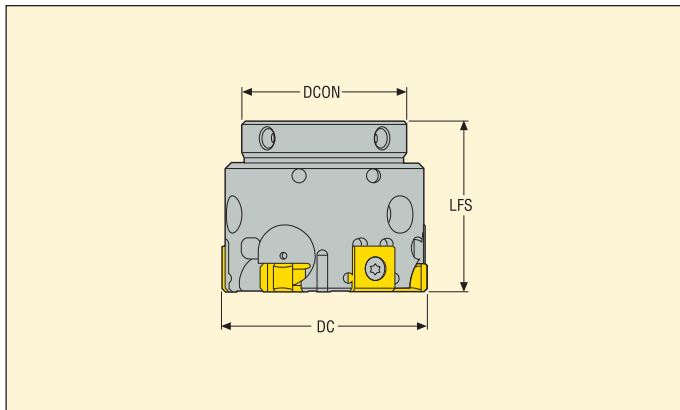

DC	Designation	Dimensions in mm		Insert	Insert	Geometries			Grades		
		LFS	DCON			EB45	EB45	EB1570	RX2000	RX1500	
39,5-44,499	HF85....03-32	33	32	3	0,41	RNAX1005....	■	■	■	■	■
44,5-49,499	HF85....03-32	33	32	3	0,51						
49,5-54,499	HF85....03-32	33	32	3	0,62						
54,5-59,499	HF85....03-32	33	32	3	0,74						

Spare Parts



<p>Insert screw</p> <p>C03010-T09P</p>	<p>Clamp screw</p> <p>LDH4010</p>	<p>Cartridge</p> <p>CARTCY-HF16</p>	<p>Wedge clamp</p> <p>B6027</p>	<p>Adjusting screw</p> <p>SH4075S</p>	<p>Setting screw radial</p> <p>HCM4 x 08</p>
<p>Torque key</p> <p>T00-09P20*</p> <p>Clamping torque (Nm)</p> <p>2</p>	<p>Torque key</p> <p>H00-2020*</p> <p>Clamping torque (Nm)</p> <p>2</p>			<p>Key (Flag)</p> <p>H2.0-2D</p>	<p>Setting key</p> <p>2SMS795</p>

*To be ordered separately.
 ■ Stock standard. Subject to change refer to current price- and stock-list

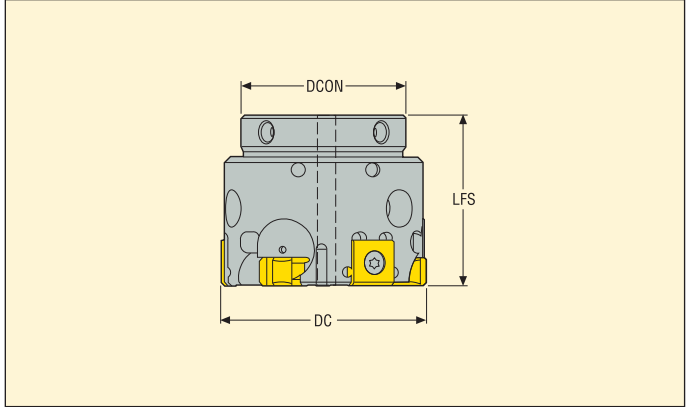
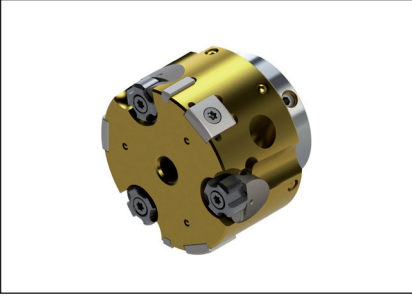









Heads for RNAX inserts, blind bore \varnothing 39,5-59,499 mm



• For inserts, grades and geometries see page(s) 329-330

DC	Designation	Dimensions in mm				Insert	Geometries			Grades	
		LFS	DCON				EB45	EB845	EB1570	RX2000	RX1500
39,5-44,499	HF85B....03-32	33	32	3	0,41	RNAX1005....	■	■	■	■	■
44,5-49,499	HF85B....03-32	33	32	3	0,51						
49,5-54,499	HF85B....03-32	33	32	3	0,62						
54,5-59,499	HF85B....03-32	33	32	3	0,74						

Spare Parts

For (mm)	Insert screw	Clamp screw	Cartridge	Wedge clamp	Adjusting screw	Setting screw radial	Plug screw
39,5-44,499							
39,5-44,499	C03010-T09P	LDH4010	CARTCY-HF16B	B6027	SH4075S	HCM4 x 08	3 x HCM3 x 03
44,5-59,499	C03010-T09P	LDH4010	CARTCY-HF16B	B6027	SH4075S	HCM4 x 08	HCM6 x 06
	Torque key 	Torque key 			Key (Flag) 	Setting key 	
	T00-09P20*	H00-2020*			H2.0-2D	2SMS795	
	Clamping torque (Nm) 2	Clamping torque (Nm) 2					

*To be ordered separately.

■ Stock standard. Subject to change refer to current price- and stock-list

Heads for LNEG inserts, through bore \varnothing 39,5-59,499 mm

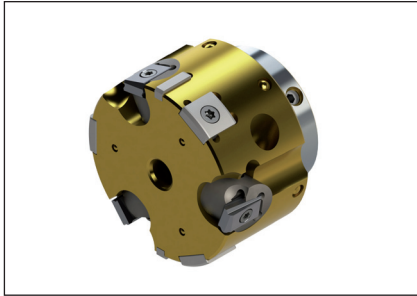



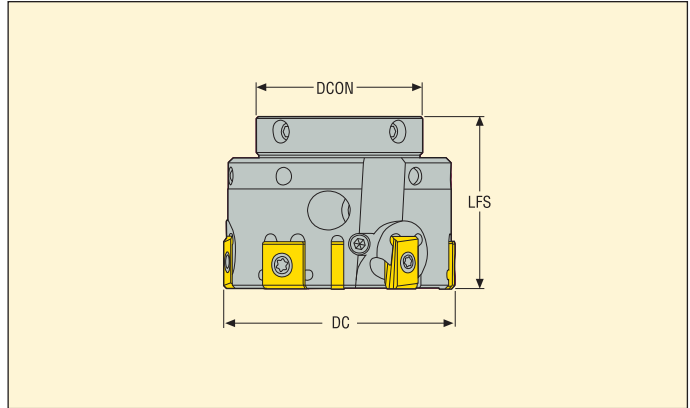







• For inserts, grades and geometries see page(s) 329-330



DC	Designation	Dimensions in mm		Insert	Insert	Geometries			Grades		
		LFS	DCON			EB45	EB45	EB1570	RX2000	RX1500	
39,5-44,499	HF86...03-32	33	32	3	0,41	LNEG1003...	■	■	■	■	■
44,5-49,499	HF86...03-32	33	32	3	0,51						
49,5-54,499	HF86...03-32	33	32	3	0,62						
54,5-59,499	HF86...03-32	33	32	3	0,74						

Spare Parts

<p>Insert screw</p>  <p>C02506-T07P</p>	<p>Clamp screw</p>  <p>LDH4010</p>	<p>Cartridge</p>  <p>CARTCY-LN16</p>	<p>Wedge clamp</p>  <p>B6027</p>	<p>Adjusting screw</p>  <p>SH4075S</p>	<p>Setting screw radial</p>  <p>HCM4 x 08</p>
<p>Torque key</p>  <p>T00-07P09*</p> <p>Clamping torque (Nm)</p> <p>0,9</p>	<p>Torque key</p>  <p>H00-2020*</p> <p>Clamping torque (Nm)</p> <p>2</p>			<p>Key (Flag)</p>  <p>H2.0-2D</p>	<p>Setting key</p>  <p>2SMS795</p>

*To be ordered separately.
 ■ Stock standard. Subject to change refer to current price- and stock-list

Heads for LNEG inserts, blind bore Ø 39,5-59,499 mm

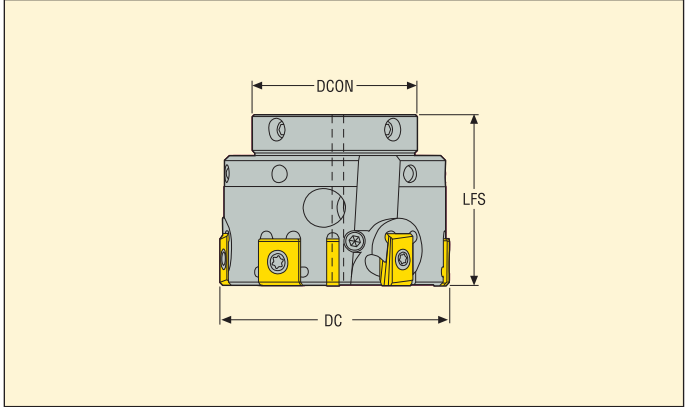
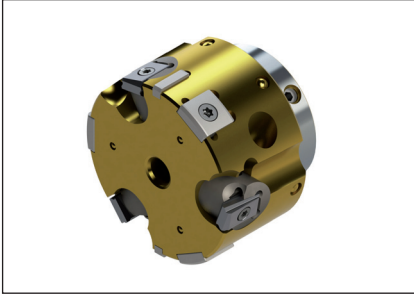

• For inserts, grades and geometries see page(s) 329-330

DC	Designation	Dimensions in mm				Insert	Geometries			Grades	
		LFS	DCON				EB45	EB45	EB1570	RX2000	RX1500
39,5-44,499	HF86B....03-32	33	32	3	0,41	LNEG1003....	■	■	■	■	■
44,5-49,499	HF86B....03-32	33	32	3	0,51						
49,5-54,499	HF86B....03-32	33	32	3	0,62						
54,5-59,499	HF86B....03-32	33	32	3	0,74						

Spare Parts

For (mm)	Insert screw	Clamp screw	Cartridge	Wedge clamp	Adjusting screw	Setting screw radial	Plug screw
39,5-44,499							
39,5-44,499	C02506-T07P	LDH4010	CARTCY-LN16B	B6027	SH4075S	HCM4 x 08	3 x HCM3 x 03
44,5-59,499	C02506-T07P	LDH4010	CARTCY-LN16B	B6027	SH4075S	HCM4 x 08	HCM6 x 06
	T00-07P09	H00-2020*			H2.0-2D	2SMS795	
	Clamping torque (Nm)	Clamping torque (Nm)					
	0,9	2					

*To be ordered separately.
■ Stock standard. Subject to change refer to current price- and stock-list

Seco-Capto™ shank for Ø 39,5-59,499 mm

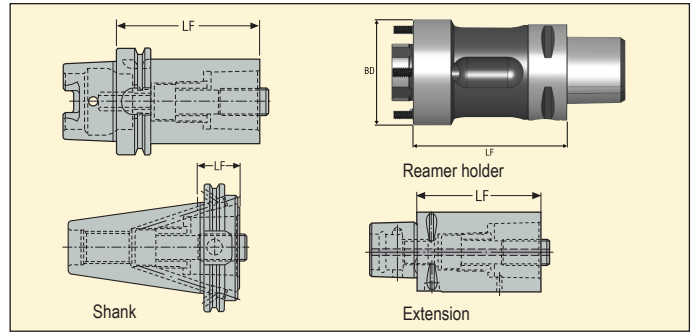

	Designation	LF	Custom design		Taper	BD	Assembly screw	KG
			LF min	LF max				
Reamer holders	HF32-050-C3	50	-	-	C3	32	4 pieces CHC M3X16	0,258
	HF32...HSKA63 C	-	65	245	HSK-A63			
	HF32...HSKA80 C	-	100	209	HSK-A80			
	HF32...HSKA100 C	-	70	245	HSK-A100			
	HF32...DIN40 ADB C	-	60	252	DIN40 ADB			
	HF32...DIN50 ADB C	-	60	317	DIN50 ADB			
	HF32...BT40 ADB C	-	65	252	BT40 ADB			
	HF32...BT50 ADB C	-	75	317	BT50 ADB			

Shanks and extensions for HF32-050-C3 (see Seco Tooling Systems for more details).

	Designation	LF	Taper	Capto size	KG
Shank	C3-390.410-63075C	75	HSK-A63	C3	0,893
	C3-390.410-100080A	80	HSK-A100	C3	2,294
	C3-390.140-40030	30	DIN40 AD	C3	0,822
	C3-390.140-40060	60	DIN40 AD	C3	0,983
	C3-390.272-40030	30	DIN40 B	C3	0,811
	C3-390.272-40060	60	DIN40 B	C3	1,2
	C3-390.540-40030	30	DIN TF40 AD	C3	0,842
	C3-390.55-40030	30	BT30 AD	C3	0,94
	C3-390.55-40060	60	BT40 AD	C3	1,2
	C3-390.369-40030	30	BT40 B	C3	0,934
	C3-390.555-40030	30	BT TF40 AD	C3	0,95
	C3-390.140-50030	30	DIN50 AD	C3	2,63
	C3-390.140-50060	60	DIN50 AD	C3	2,744
	C3-390.272-50030	30	DIN50 B	C3	2,6
	C3-390.272-50060	60	DIN50 B	C3	2,8
	C3-390.540-50030A	30	DIN TF50 ADB	C3	2,633
	C3-390.58-50040	40	BT50 ADB	C3	2,5
	C3-390.58-50070	70	BT50 ADB	C3	2,7
	C3-390.369-50040	40	BT50 B	C3	3,6

	Designation	LF	Taper	Capto size	KG
Extension	C3-391.01-32060A	60	C3	C3	0,336
	C3-391.01-32080A	80	C3	C3	0,449
	C4-391.02-32055A	55	C3	C4	0,418
	C4-391.02-32070A	70	C3	C4	0,559
	C5-391.02-32060A	60	C3	C5	0,637
	C6-391.02-32070A	70	C3	C6	1,06
	C8-391.02-32060A	60	C3	C8	1,722

Graflex® shank for Ø 39,5-59,499 mm

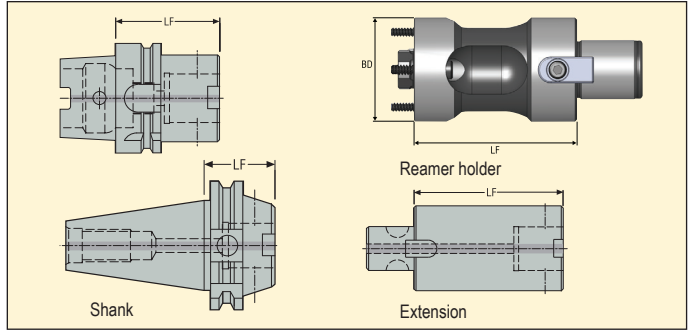

	Designation	LF	Custom design		Taper	BD	Assembly screw	KG
			LF min	LF max				
Reamer holders	HF32-050-G3	50	-	-	G3	32	4 pieces CHC M3X16	0,32
	HF32...HSKA63	-	65	245	HSK-A63			
	HF32...HSKA80	-	100	209	HSK-A80			
	HF32...HSKA100	-	70	245	HSK-A100			
	HF32...DIN40 ADB	-	60	252	DIN40 ADB			
	HF32...DIN50 ADB	-	60	317	DIN50 ADB			
	HF32...BT40 ADB	-	65	252	BT40 ADB			
	HF32...BT50 ADB	-	75	317	BT50 ADB			

Shanks and extensions for HF32-050-G3 (see Seco Tooling Systems for more details).

	Designation	LF	Taper	Graflex size	KG
Shank	EM93044011850	50	HSK-A63	G3	0,73
	EM93064011855	55	HSK-A100	G3	2,1
	EM34694011835	35	DIN40 ADB	G3	0,908
	EM346940118100	100	DIN40 ADB	G3	1,215
	EM34144011840	40	BT40 ADB	G3	1,061
	EM341440118100	100	BT40 ADB	G3	1,308
	EM34714011835	35	DIN50 ADB	G3	2,67
	EM34164011845	45	BT50 ADB	G3	3,58
	EM341640118120	120	BT50 ADB	G3	3,9

	Designation	LF	Taper	Graflex size	KG
Extension	M402330	40	G3	G3	0,231
	M402331	60	G3	G3	0,356

Heads for RNAX inserts, through bore \varnothing 59,5-84,499 mm

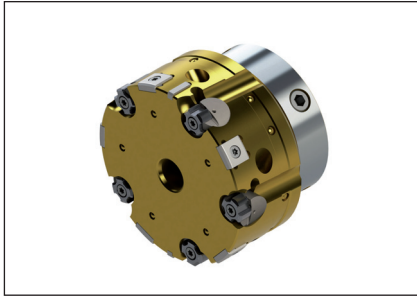

• For inserts, grades and geometries see page(s) 329-330

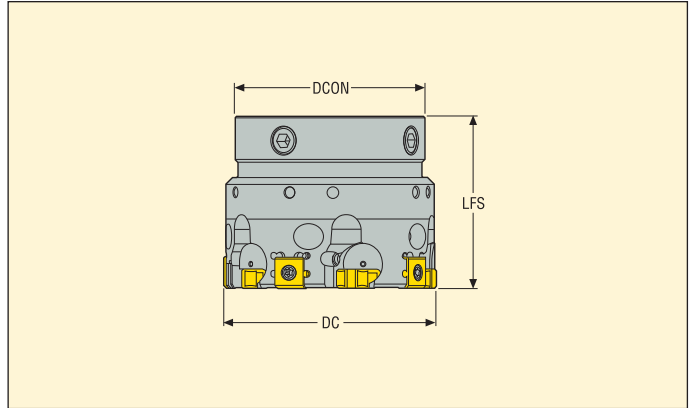

DC	Designation	Dimensions in mm				Insert	Geometries			Grades	
		LFS	DCON				EB45	EB45	EB1570	RX2000	RX1500
59,5-64,499	HF85....05-55	50	55	5	1,30	RNAX1005....	■	■	■	■	■
64,5-69,499	HF85....05-55	50	55	5	1,50						
69,5-74,499	HF85....05-55	50	55	5	1,75						
74,5-79,499	HF85....05-55	50	55	5	2,00						
79,5-84,499	HF85....05-55	50	55	5	2,20						

Spare Parts

<p>Insert screw</p> <p>C03010-T09P</p>	<p>Clamp screw</p> <p>LDH4012</p>	<p>Cartridge</p> <p>CARTCY-HF20</p>	<p>Wedge clamp</p> <p>B6027</p>	<p>Adjusting screw</p> <p>SH4075S</p>	<p>Setting screw radial</p> <p>HCM8 x 12</p>
<p>Torque key</p> <p>T00-09P20*</p> <p>Clamping torque (Nm)</p> <p>2</p>	<p>Torque key</p> <p>H00-2020*</p> <p>Clamping torque (Nm)</p> <p>2</p>			<p>Key (Flag)</p> <p>H2.0-2D</p>	<p>Setting key</p> <p>4SMS795</p>

*To be ordered separately.
 ■ Stock standard. Subject to change refer to current price- and stock-list

Heads for RNAX inserts, blind bore \varnothing 59,5-84,499 mm

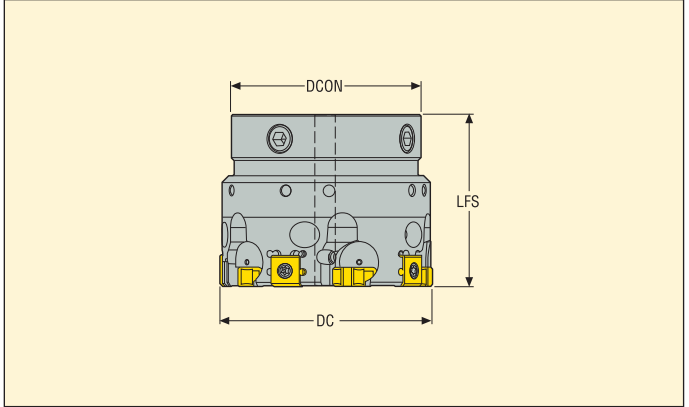
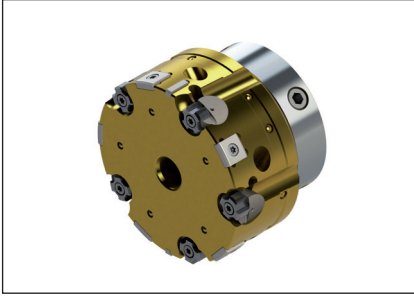

• For inserts, grades and geometries see page(s) 329-330

DC	Designation	Dimensions in mm				Insert	Geometries			Grades	
		LFS	DCON				EB45	EB45	EB1570	RX2000	RX1500
59,5-64,499	HF85B....05-55	50	55	5	1,30	RNAX1005...	■	■	■	■	■
64,5-69,499	HF85B....05-55	50	55	5	1,50						
69,5-74,499	HF85B....05-55	50	55	5	1,75						
74,5-79,499	HF85B....05-55	50	55	5	2,00						
79,5-84,499	HF85B....05-55	50	55	5	2,20						

Spare Parts

<p>Insert screw</p> <p>C03010-T09P</p>	<p>Clamp screw</p> <p>LDH4012</p>	<p>Cartridge</p> <p>CARTCY-HF20B</p>	<p>Wedge clamp</p> <p>B6027</p>	<p>Adjusting screw</p> <p>SH4075S</p>	<p>Setting screw radial</p> <p>HCM8 x 12</p>	<p>Plug screw</p> <p>HCM10 x 10</p>
<p>Torque key</p> <p>T00-09P20*</p> <p>Clamping torque (Nm)</p> <p>2</p>	<p>Torque key</p> <p>H00-2020*</p> <p>Clamping torque (Nm)</p> <p>2</p>			<p>Key (Flag)</p> <p>H2.0-2D</p>	<p>Setting key</p> <p>2SMS795</p>	

*To be ordered separately.
 ■ Stock standard. Subject to change refer to current price- and stock-list

Heads for LNEG inserts, through bore \varnothing 59,5-84,499 mm

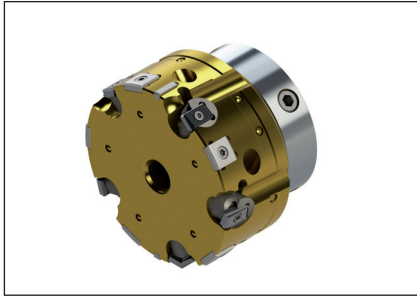



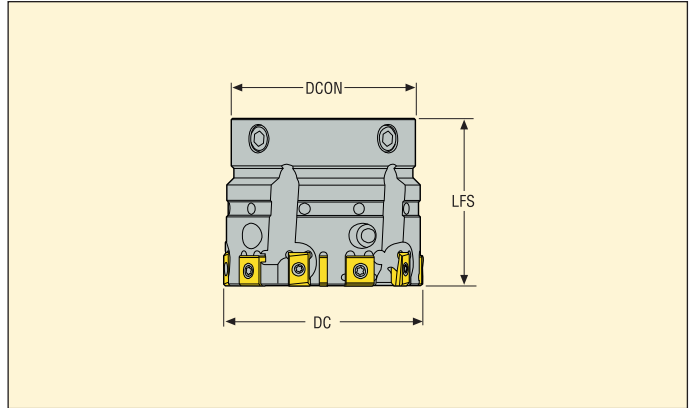







• For inserts, grades and geometries see page(s) 329-330



DC	Designation	Dimensions in mm		Insert	Geometries			Grades			
		LFS	DCON		EB45	EB45	EB1570	RX2000	RX1500		
59,5-64,499	HF86....05-55	50	55	5	1,30	LNEG1003....	■	■	■	■	■
64,5-69,499	HF86....05-55	50	55	5	1,50						
69,5-74,499	HF86....05-55	50	55	5	1,75						
74,5-79,499	HF86....05-55	50	55	5	2,00						
79,5-84,499	HF86....05-55	50	55	5	2,20						

Spare Parts

<p>Insert screw</p>  <p>C02506-T07P</p>	<p>Clamp screw</p>  <p>LDH4010</p>	<p>Cartridge</p>  <p>CARTCY-LN20</p>	<p>Wedge clamp</p>  <p>B6027</p>	<p>Adjusting screw</p>  <p>SH4075S</p>	<p>Setting screw radial</p>  <p>HCM8 x 12</p>
<p>Torque key</p>  <p>T00-07P09</p> <p>Clamping torque (Nm)</p> <p>0,9</p>	<p>Torque key</p>  <p>H00-2020*</p> <p>Clamping torque (Nm)</p> <p>2</p>			<p>Key (Flag)</p>  <p>H2.0-2D</p>	<p>Setting key</p>  <p>2SMS795</p>

*To be ordered separately.
 ■ Stock standard. Subject to change refer to current price- and stock-list

Heads for LNEG inserts, blind bore \varnothing 59,5-84,499 mm

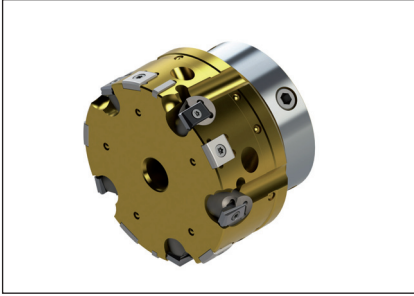

• For inserts, grades and geometries see page(s) 329-330

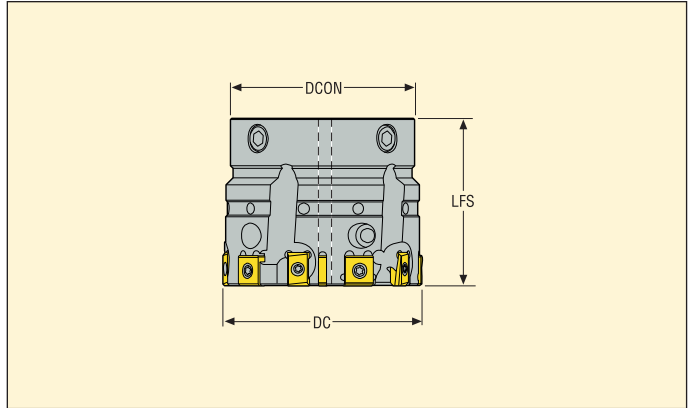

DC	Designation	Dimensions in mm				Insert	Geometries			Grades	
		LFS	DCON				EB45	EB845	EB1570	RX2000	RX1500
59,5-64,499	HF86B....05-55	50	55	5	1,30	LNEG1003...	■	■	■	■	■
64,5-69,499	HF86B....05-55	50	55	5	1,50						
69,5-74,499	HF86B....05-55	50	55	5	1,75						
74,5-79,499	HF86B....05-55	50	55	5	2,00						
79,5-84,499	HF86B....05-55	50	55	5	2,20						

Spare Parts

<p>Insert screw</p> <p>C02506-T07P</p>	<p>Clamp screw</p> <p>LDH4010</p>	<p>Cartridge</p> <p>CARTCY-LN20B</p>	<p>Wedge clamp</p> <p>B6027</p>	<p>Adjusting screw</p> <p>SH4075S</p>	<p>Setting screw radial</p> <p>HCM8 x 12</p>	<p>Plug screw</p> <p>HCM10 x 10</p>
<p>Torque key</p> <p>T00-07P09</p> <p>Clamping torque (Nm)</p> <p>0,9</p>	<p>Torque key</p> <p>H00-2020*</p> <p>Clamping torque (Nm)</p> <p>2</p>			<p>Key (Flag)</p> <p>H2.0-2D</p>	<p>Setting key</p> <p>2SMS795</p>	

*To be ordered separately.
 ■ Stock standard. Subject to change refer to current price- and stock-list

Seco-Capto™ shank for Ø 59,5-84,499 mm

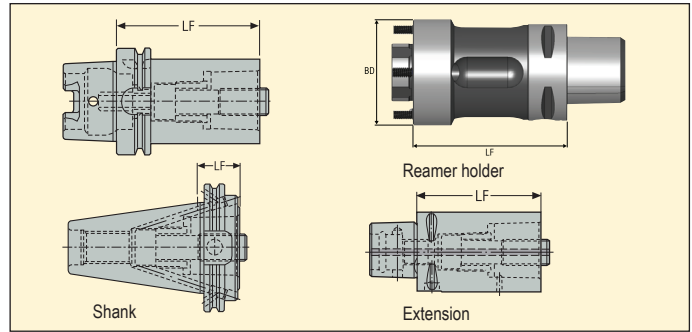

	Designation	LF	Custom design		Taper	BD	Assembly screw	KG
			LF min	LF max				
Reamer holders	HF55-080-C5	80	-	-	C5	55	4 pieces CHC M5X25	1,423
	HF55...HSCA63	-	80	239	HSK-A63			
	HF55...HSCA80	-	100	239	HSK-A80			
	HF55...HSCA100	-	100	239	HSK-A100			
	HF55...DIN69871/40	-	80	239	DIN6971/40			
	HF55...DIN69871/50	-	80	304	DIN6971/50			
	HF55...BT40 ADB	-	80	239	BT40 ADB			
	HF55...BT50 ADB	-	80	304	BT50 ADB			



Shanks and extensions for HF55-080-C5 (see Seco Tooling Systems for more details).

	Designation	LF	Taper	Capto size	KG
Shank	C5-390.410-63090C	90	HSK-A63	C5	1,402
	C5-390.410-100100A	100	HSK-A100	C5	2,894
	C5-390.140-40030	30	DIN40 AD	C5	0,8
	C5-390.140-40070	70	DIN40 AD	C5	1,1
	C5-390.272-40040	40	DIN40 B	C5	0,896
	C5-390.272-40080	80	DIN40 B	C5	1,48
	C5-390.540-40050	50	DIN TF40 AD	C5	1,078
	C5-390.55-40030	30	BT40 AD	C5	0,82
	C5-390.55-40070	70	BT40 AD	C5	1,392
	C5-390.369-40050	50	BT40 B	C5	1,09
	C5-390.555-40050	50	BT TF40 AD	C5	1,112
	C5-390.140-50030	30	DIN50 AD	C5	2,58
	C5-390.140-50070	70	DIN50 AD	C5	3,08
	C5-390.272-50030	30	DIN50 B	C5	2,76
	C5-390.272-50070-OBS	70	DIN50 B	C5	3,3
	C5-390.540-50030A	30	DIN TF50 ADB	C5	2,594
	C5-390.58-50040	40	BT50 AD	C5	3,42
	C5-390.58-50080	80	BT50 AD	C5	3,94
	C5-390.369-50040	40	BT50 B	C5	1,25
	C5-390.558-50040	40	BT TF50 AD	C5	3,46

	Designation	LF	Taper	Capto size	KG
Extension	C5-391.01-50080A	80	C5	C5	1,114
	C5-391.01-50100A	100	C5	C5	1,39
	C6-391.02-50080A	80	C5	C6	1,448
	C6-391.02-50110A	110	C5	C6	2,15
	C8-391.02-50080A	80	C5	C8	2,202

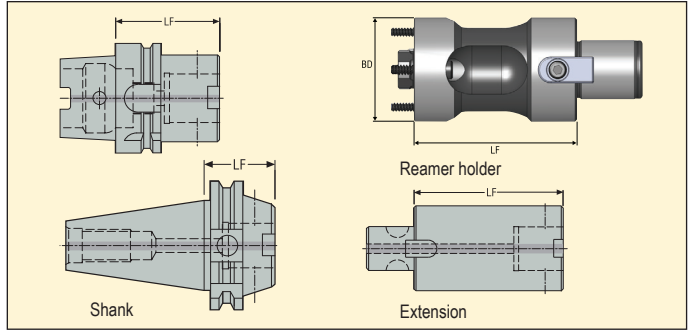
Graflex® shank for Ø 59,5-84,499 mm



	Designation	LF	Custom design		Taper	BD	Assembly screw 	
			LF min	LF max				
Reamer holders	HF55-080-G5	80	-	-	G5	55	4 pieces CHC M5X25	1,278
	HF55...HSKA63	-	80	239	HSK-A63			
	HF55...HSKA80	-	100	239	HSK-A80			
	HF55...HSKA100	-	100	239	HSK-A100			
	HF55...DIN69871/40	-	80	239	DIN6971/40			
	HF55...DIN69871/50	-	80	304	DIN6971/50			
	HF55...BT40 ADB	-	80	239	BT40 ADB			
	HF55...BT50 ADB	-	80	304	BT50 ADB			

Shanks and extensions for HF55-080-G5 (see Seco Tooling Systems for more details).

	Designation	LF	Taper	Graflex size	
Shank	EM93044012860	60	HSK-A63	G5	0,975
	EM930440128100	100	HSK-A63	G5	1,574
	EM930440128140	140	HSK-A63	G5	2,182
	EM93064012865	65	HSK-A100	G5	2,364
	EM930640128110	110	HSK-A100	G5	3,02
	EM930640128150	150	HSK-A100	G5	3,675
	EM34694012840	40	DIN40 ADB	G5	0,922
	EM34694012880	80	DIN40 ADB	G5	1,492
	EM346940128120	120	DIN40 ADB	G5	2,08
	EM34144012845	45	BT40 ADB	G5	1,112
	EM34144012880	80	BT40 ADB	G5	1,54
	EM341440128120	120	BT40 ADB	G5	2,12
	EM34714012840	40	DIN50 ADB	G5	2,748
	EM341640128100	100	BT50 ADB	G5	4,22
	EM34164012855	55	BT50 ADB	G5	3,964
	EM341640128140	140	BT50 ADB	G5	4,8

	Designation	LF	Taper	Graflex size	
Extension	M402550	50	G5	G5	0,72
	M402551	75	G5	G5	1,11
	M402552	100	G5	G5	1,476

Heads for RNAX inserts, through bore \varnothing 84,5-119,499 mm

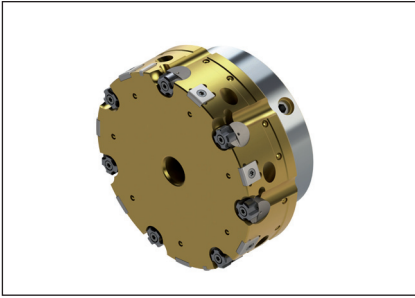

• For inserts, grades and geometries see page(s) 329-330

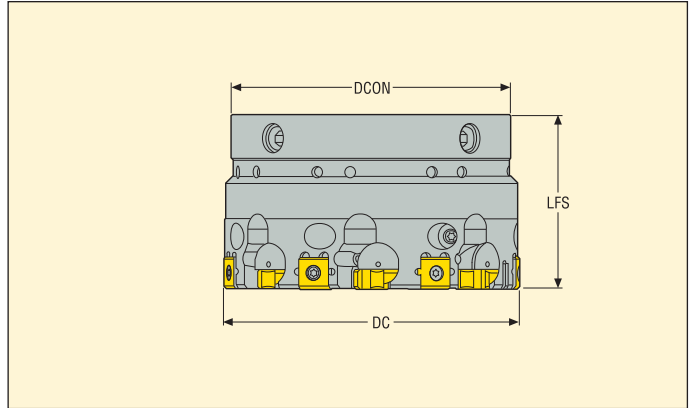

DC	Designation	Dimensions in mm				Insert	Geometries			Grades	
		LFS	DCON				EB45	EB45	EB1570	RX2000	RX1500
84,5-89,499	HF85....07-80	50	80	7	1,68	RNAX1005...	■	■	■	■	■
89,5-94,499	HF85....07-80	50	80	7	1,85						
94,5-99,499	HF85....07-80	50	80	7	2,02						
99,5-104,499	HF85....07-80	50	80	7	2,20						
104,5-109,499	HF85....07-80	50	80	7	2,40						
109,5-114,499	HF85....07-80	50	80	7	2,61						
114,5-119,499	HF85....07-80	50	80	7	2,82						

Spare Parts

Insert screw C03010-T09P	Clamp screw LDH4012	Cartridge CARTCY-HF20	Wedge clamp B6027	Adjusting screw SH4075S	Setting screw radial HCM8 x 16
Torque key T00-09P20*	Torque key H00-2020*			Key (Flag) H2.0-2D	Setting key 4SMS795
Clamping torque (Nm)	Clamping torque (Nm)				
2	2				

*To be ordered separately.

■ Stock standard. Subject to change refer to current price- and stock-list

Heads for RNAX inserts, blind bore \varnothing 84,5-119,499 mm

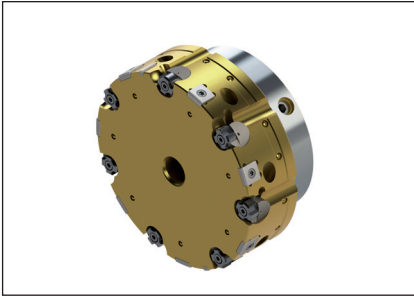

• For inserts, grades and geometries see page(s) 329-330

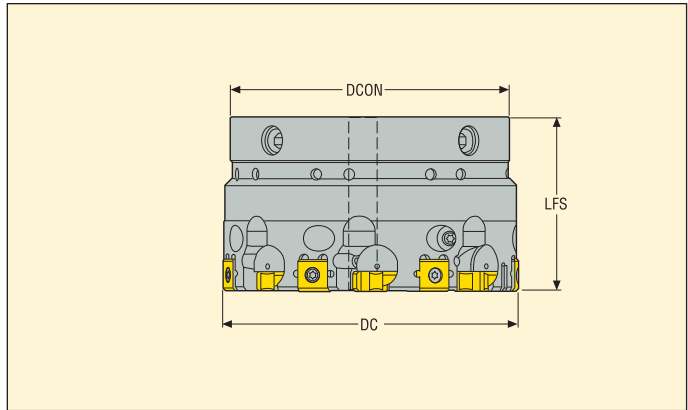

DC	Designation	Dimensions in mm				Insert	Geometries			Grades	
		LFS	DCON				EB45	EB45	EB15/70	RX2000	RX1500
84,5-89,499	HF85B....07-80	50	80	7	1,68	RNAX1005....	■	■	■	■	■
89,5-94,499	HF85B....07-80	50	80	7	1,85						
94,5-99,499	HF85B....07-80	50	80	7	2,02						
99,5-104,499	HF85B....07-80	50	80	7	2,20						
104,5-109,499	HF85B....07-80	50	80	7	2,40						
109,5-114,499	HF85B....07-80	50	80	7	2,61						
114,5-119,499	HF85B....07-80	50	80	7	2,82						

Spare Parts

C03010-T09P	LDH4010	CARTCY-LN20B	B6027	SH4075S	HCM8 x 16	HCM12 x 10
T00-09P20*	H00-2020*			H2.0-2D	2SMS795	
Clamping torque (Nm)	Clamping torque (Nm)					
2	2					

*To be ordered separately.
■ Stock standard. Subject to change refer to current price- and stock-list

Heads for LNEG inserts, through bore \varnothing 84,5-119,499 mm

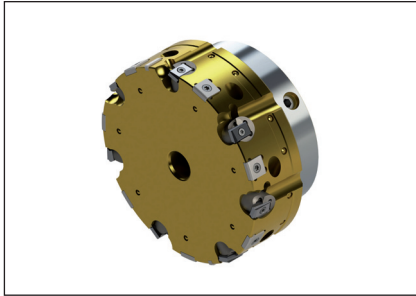

• For inserts, grades and geometries see page(s) 329-330

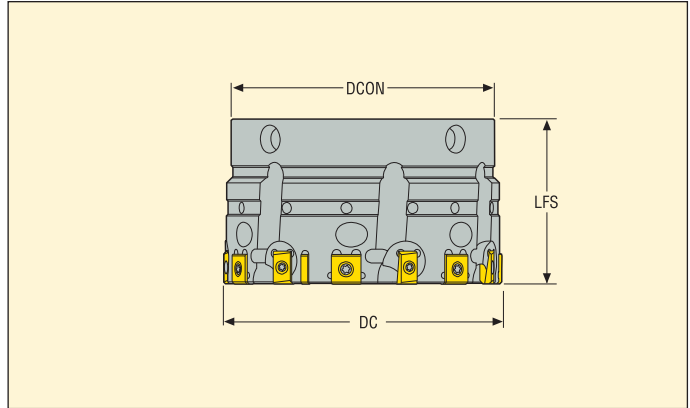

DC	Designation	Dimensions in mm				Insert	Geometries			Grades	
		LFS	DCON				EB45	EB45	EB1570	RX2000	RX1500
84,5-89,499	HF86....07-80	50	80	7	1,68	LNEG1003....	■	■	■	■	■
89,5-94,499	HF86....07-80	50	80	7	1,85						
94,5-99,499	HF86....07-80	50	80	7	2,02						
99,5-104,499	HF86....07-80	50	80	7	2,20						
104,5-109,499	HF86....07-80	50	80	7	2,40						
109,5-114,499	HF86....07-80	50	80	7	2,61						
114,5-119,499	HF86....07-80	50	80	7	2,82						

Spare Parts

Insert screw	Clamp screw	Cartridge	Wedge clamp	Adjusting screw	Setting screw radial
C02506-T07P	LDH4010	CARTCY-HF16	B6027	SH4075S	HCM8 x 16
Torque key	Torque key			Key (Flag)	Setting key
T00-07P09	H00-2020*			H2.0-2D	2SMS795
Clamping torque (Nm)	Clamping torque (Nm)				
0,9	2				

*To be ordered separately.
 ■ Stock standard. Subject to change refer to current price- and stock-list

Heads for LNEG inserts, blind bore $\varnothing 84,5-119,499$ mm

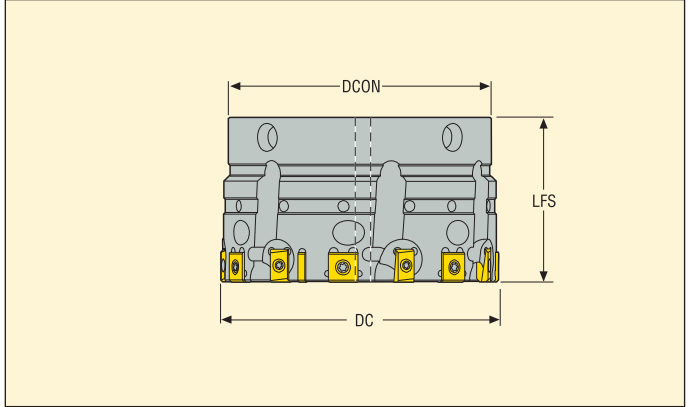
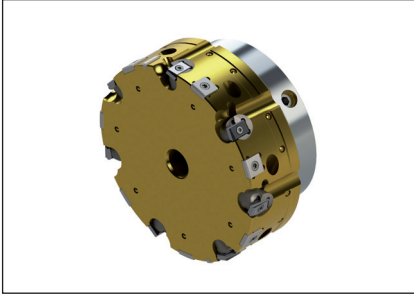

• For inserts, grades and geometries see page(s) 329-330

DC	Designation	Dimensions in mm				Insert	Geometries			Grades	
		LFS	DCON				EB45	EB45	EB15/70	RX2000	RX1500
84,5-89,499	HF86B....07-80	50	80	7	1,68	LNEG1003....	■	■	■	■	■
89,5-94,499	HF86B....07-80	50	80	7	1,85						
94,5-99,499	HF86B....07-80	50	80	7	2,02						
99,5-104,499	HF86B....07-80	50	80	7	2,20						
104,5-109,499	HF86B....07-80	50	80	7	2,40						
109,5-114,499	HF86B....07-80	50	80	7	2,61						
114,5-119,499	HF86B....07-80	50	80	7	2,82						

Spare Parts

C02506-T07P	LDH4010	CARTCY-HF16B	B6027	SH4075S	HCM8 x 16	HCM12 x 10
T00-07P09	H00-2020*			H2.0-2D	2SMS795	
Clamping torque (Nm)	Clamping torque (Nm)					
0,9	2					

*To be ordered separately.
 ■ Stock standard. Subject to change refer to current price- and stock-list

Seco-Capto™ shank for Ø 84,5-119,499 mm

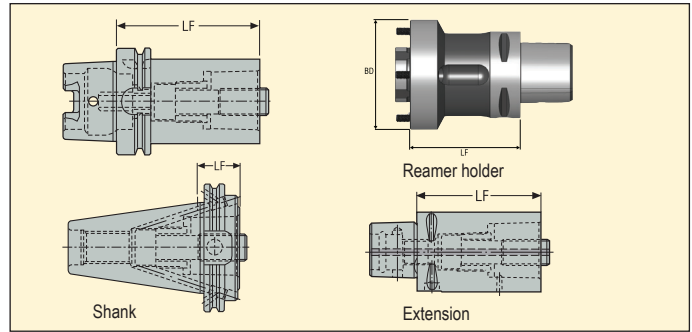

	Designation	LF	Custom design		Taper	BD	Assembly screw	KG
			LF min	LF max				
Reamer holders	HF80-080-C6	80	-	-	C6	80	4 pieces CHC M6X25	2,428
	HF80...HSKA80	-	100	239	HSK-A80			
	HF80...HSKA100	-	100	239	HSK-A100			
	HF80...DIN699871/50	-	80	304	DIN69871/50			
	HF80...BT50	-	80	304	BT50			



Shanks and extensions for HF80-080-C6 (see Seco Tooling Systems for more details).

	Designation	LF	Taper	Capto size	KG
Shank	C6-390.410-100110A	110	HSK-A100	C6	3,56
	C6-390.140-40085	85	DIN40 AD	C6	1,796
	C6-390.272-40085	85	DIN40 B	C6	1,776
	C6-390.540-40085	85	DIN TF40 AD	C6	1,818
	C6-390.140-50030	30	DIN50 AD	C6	2,494
	C6-390.140-50080	80	DIN50 AD	C6	3,58
	C6-390.272-50030	30	DIN50 B	C6	2,6
	C6-390.272-50080	80	DIN50 B	C6	3,7
	C6-390.540-50050A	50	DIN TF50 ADB	C6	2,4
	C6-390.55-40075	75	BT40 AD	C6	2,678
	C6-390.555-40075	75	BT TF40 AD	C6	1,7
	C6-390.58-50040	40	BT50 AD	C6	3,4
	C6-390.58-50090	90	BT50 AD	C6	4,35
	C6-390.369-50050	50	BT50 B	C6	3,44
	C6-390.558-50050/OBS	50	BT TF50 AD	C6	3,662

	Designation	LF	Taper	Capto size	KG
Extension	C6-391.01-63100A	100	C6	C6	2,196
	C6-391.01-63140A	140	C6	C6	3,1
	C6-391.01-63060	60	C6	C6	1,304

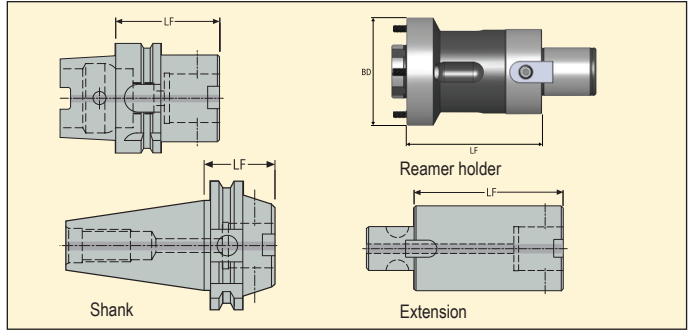
Graflex® shank for Ø 84,5-119,499 mm



	Designation	LF	Custom design		Taper	BD	Assembly screw 	
			LF min	LF max				
Reamer holders	HF80-080-G6	80	-	-	G6	80	4 pieces CHC M6X25	2,91
	HF80...HSKA80	-	100	239	HSK-A80			
	HF80...HSKA100	-	100	239	HSK-A100			
	HF80...DIN699871/50	-	80	304	DIN69871/50			
	HF80...BT50	-	80	304	BT50			

Shanks and extensions for HF80-080-G6 (see Seco Tooling Systems for more details).

	Designation	LF	Taper	Graflex size	
Shank	EM93044013670	70	HSK-A63	G6	1,206
	EM930440136120	120	HSK-A63	G6	2,38
	EM930640136120	120	HSK-A100	G6	3,82
	EM930640136160	160	HSK-A100	G6	4,72
	EM34694013660	60	DIN40 ADB	G6	1,238
	EM346940136120	120	DIN40 ADB	G6	2,646
	EM34144013650	50	BT40 ADB	G6	1,126
	EM341440136120	120	BT40 ADB	G6	2,78
	EM34714013645	45	DIN50 ADB	G6	2,88
	EM347140136100	100	DIN50 ADB	G6	4,08
	EM347140136140	140	DIN50 ADB	G6	4,989
	EM446840136140	-	DIN50 AD/ CAT50	G6	5,1
	EM34164013663	63	BT50 ADB	G6	4,2
	EM341640136100	100	BT50 ADB	G6	4,6
	EM341640136140	140	BT50 ADB	G6	5,54

	Designation	LF	Taper	Graflex size	
Extension	M402660	60	G6	G6	1,376
	M402661	90	G6	G6	2,097
	M402662	120	G6	G6	2,814

Heads for RNAX inserts, through bore $\varnothing 119,5-154,499$ mm

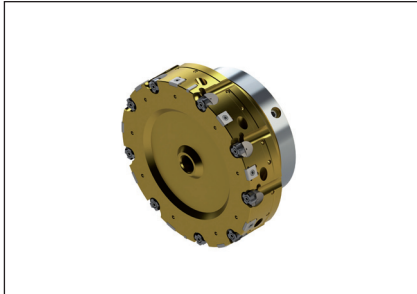

• For inserts, grades and geometries see page(s) 329-330

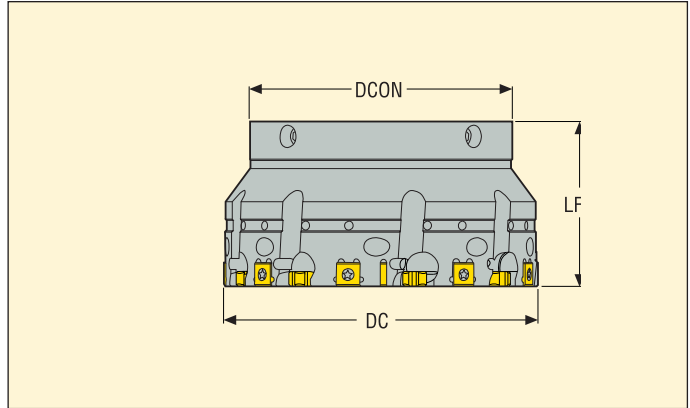

DC	Designation	Dimensions in mm				Insert	Geometries			Grades	
		LFS	DCON				EB45	EB45	EB1570	RX2000	RX1500
119,5-124,499	HF85....09-100	63	100	9	3,89	RNAX1005....	■	■	■	■	■
124,5-129,499	HF85....09-100	63	100	9	4,15						
129,5-134,499	HF85....09-100	63	100	9	4,42						
134,5-139,499	HF85....09-100	63	100	9	4,70						
139,5-144,499	HF85....09-100	63	100	9	4,99						
144,5-149,499	HF85....09-100	63	100	9	5,29						
149,5-154,499	HF85....09-100	63	100	9	5,60						

Spare Parts

<p>Insert screw</p> <p>C03010-T09P</p>	<p>Clamp screw</p> <p>LDH4012</p>	<p>Cartridge</p> <p>CARTCY-HF20</p>	<p>Wedge clamp</p> <p>B6027</p>	<p>Adjusting screw</p> <p>SH4075S</p>	<p>Setting screw radial</p> <p>HCM8 x 20</p>
<p>Torque key</p> <p>T00-09P20*</p> <p>Clamping torque (Nm)</p> <p>2</p>	<p>Torque key</p> <p>H00-2020*</p> <p>Clamping torque (Nm)</p> <p>2</p>			<p>Key (Flag)</p> <p>H2.0-2D</p>	<p>Setting key</p> <p>4SMS795</p>

*To be ordered separately.
 ■ Stock standard. Subject to change refer to current price- and stock-list

Heads for RNAX inserts, blind bore $\varnothing 119,5-154,499$ mm

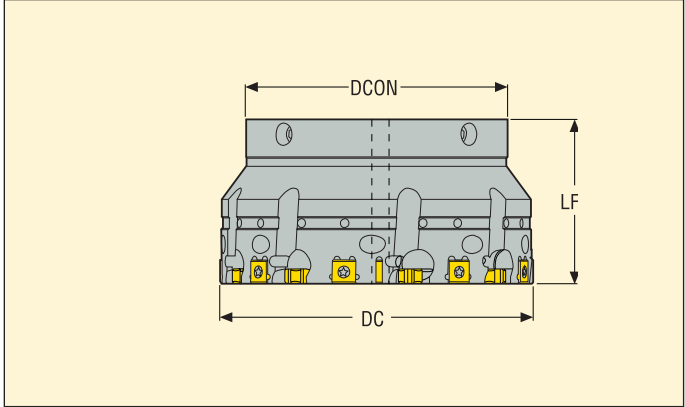
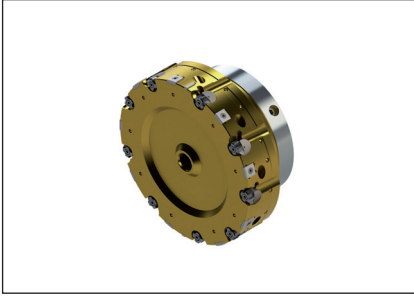

• For inserts, grades and geometries see page(s) 329-330

DC	Designation	Dimensions in mm				Insert	Geometries			Grades	
		LFS	DCON				EB45	EB45	EB1570	RX2000	RX1500
119,5-124,499	HF85B....09-100	63	100	9	3,89	RNAX1005...					
124,5-129,499	HF85B....09-100	63	100	9	4,15						
129,5-134,499	HF85B....09-100	63	100	9	4,42						
134,5-139,499	HF85B....09-100	63	100	9	4,70		■	■	■	■	■
139,5-144,499	HF85B....09-100	63	100	9	4,99						
144,5-149,499	HF85B....09-100	63	100	9	5,29						
149,5-154,499	HF85B....09-100	63	100	9	5,60						

Spare Parts

Insert screw 	Clamp screw 	Cartridge 	Wedge clamp 	Adjusting screw 	Setting screw radial 	Plug screw
C03010-T09P	LDH4010	CARTCY-HF16B	B6027	SH4075S	HCM8 x 20	HCM12 x 10
Torque key 	Torque key 			Key (Flag) 	Setting key 	
T00-09P20*	H00-2020*			H2.0-2D	2SMS795	
Clamping torque (Nm)	Clamping torque (Nm)					
2	2					

*To be ordered separately.

■ Stock standard. Subject to change refer to current price- and stock-list

Heads for LNEG inserts, through bore \varnothing 119,5-154,499 mm

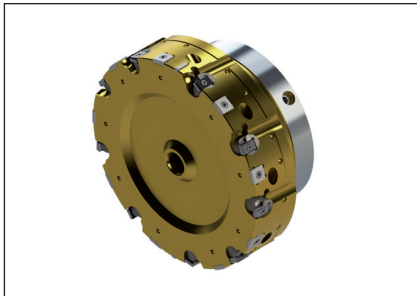

• For inserts, grades and geometries see page(s) 329-330

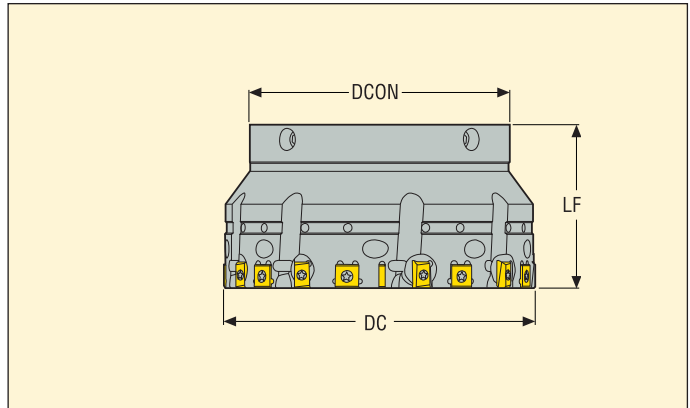

DC	Designation	Dimensions in mm				Insert	Geometries			Grades	
		LFS	DCON				EB45	EB45	EB1570	RX2000	RX1500
119,5-124,499	HF86....09-100	63	100	9	3,89	LNEG1003....	■	■	■	■	■
124,5-129,499	HF86....09-100	63	100	9	4,15						
129,5-134,499	HF86....09-100	63	100	9	4,42						
134,5-139,499	HF86....09-100	63	100	9	4,70						
139,5-144,499	HF86....09-100	63	100	9	4,99						
144,5-149,499	HF86....09-100	63	100	9	5,29						
149,5-154,499	HF86....09-100	63	100	9	5,60						

Spare Parts

<p>Insert screw</p> <p>C02506-T07P</p>	<p>Clamp screw</p> <p>LDH4010</p>	<p>Cartridge</p> <p>CARTCY-HF16</p>	<p>Wedge clamp</p> <p>B6027</p>	<p>Adjusting screw</p> <p>SH4075S</p>	<p>Setting screw radial</p> <p>HCM8 x 20</p>
<p>Torque key</p> <p>T00-07P09</p>	<p>Torque key</p> <p>H00-2020*</p>			<p>Key (Flag)</p> <p>H2.0-2D</p>	<p>Setting key</p> <p>2SMS795</p>
<p>Clamping torque (Nm)</p> <p>0,9</p>	<p>Clamping torque (Nm)</p> <p>2</p>				

*To be ordered separately.
 ■ Stock standard. Subject to change refer to current price- and stock-list

Heads for LNEG inserts, blind bore $\varnothing 119,5-154,499$ mm

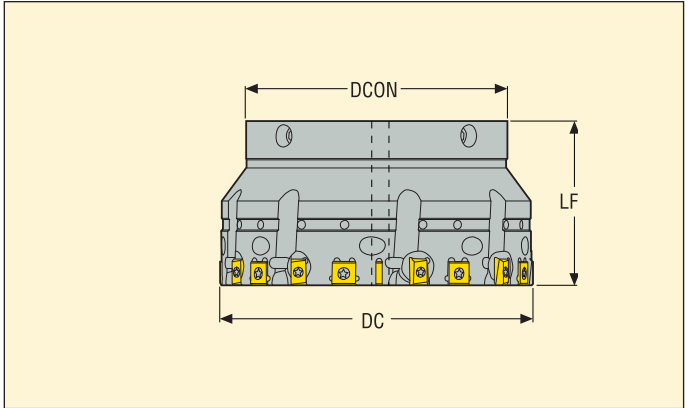
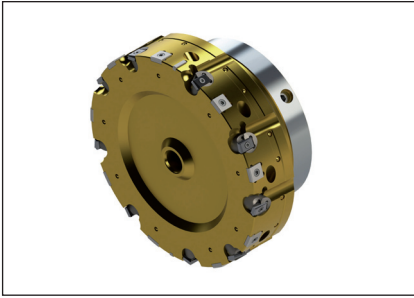

• For inserts, grades and geometries see page(s) 329-330

DC	Designation	Dimensions in mm				Insert	Geometries			Grades	
		LFS	DCON				EB45	EB845	EB1570	RX2000	RX1500
119,5-124,499	HF86B....09-100	63	100	9	3,89	LNEG1003....					
124,5-129,499	HF86B....09-100	63	100	9	4,15						
129,5-134,499	HF86B....09-100	63	100	9	4,42						
134,5-139,499	HF86B....09-100	63	100	9	4,70		■	■	■	■	■
139,5-144,499	HF86B....09-100	63	100	9	4,99						
144,5-149,499	HF86B....09-100	63	100	9	5,29						
149,5-154,499	HF86B....09-100	63	100	9	5,60						

Spare Parts

 Insert screw C02506-T07P	 Clamp screw LDH4010	 Cartridge CARTCY-HF16B	 Wedge clamp B6027	 Adjusting screw SH4075S	 Setting screw radial HCM8 x 20	 Plug screw HCM12 x 10
 Torque key T00-07P09 Clamping torque (Nm) 0,9	 Torque key H00-2020* Clamping torque (Nm) 2			 Key (Flag) H2.0-2D	 Setting key 2SMS795	

*To be ordered separately.
 ■ Stock standard. Subject to change refer to current price- and stock-list

Seco-Capto™ shank for Ø 119,5-154,499 mm

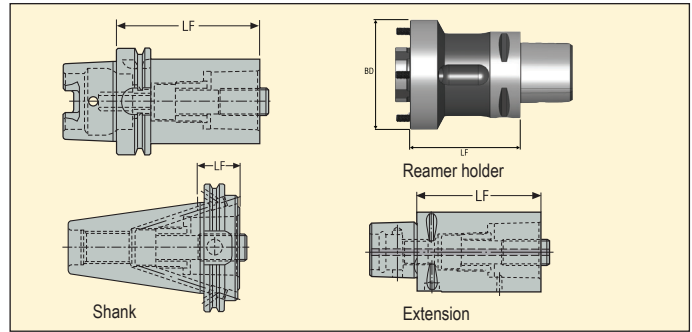

	Designation	LF	Custom design		Taper	BD	Assembly screw	KG
			LF min	LF max				
Reamer holders	HF100-100-C8	100	-	-	C8	100	4 pieces CHC M8X30	4,84
	HF100...HSKA80	-	100	238	HSK-A80			
	HF100...HSKA100	-	100	238	HSK-A100			
	HF100...DIN6987/50	-	100	238	DIN50 ADB			
	HF100...BT50	-	100	238	BT50 ADB			



Shanks and extensions for HF100-100-C8 (see Seco Tooling Systems for more details).

	Designation	LF	Taper	Capto size	KG
Shank	C8-390.410-100120A	120	HSK-A100	C8	4,72
	C8-390.140-50070	70	DIN50 AD	C8	3,7
	C8-390.140-50120	120	DIN50 AD	C8	5,54
	C8-390.272-50070	70	DIN50 B	C8	3,68
	C8-390.272-50120	120	DIN50 B	C8	5,52
	C8-390.540-50070A	70	DIN TF50 ADB	C8	3,72
	C8-390.58-50070	70	BT50 AD	C8	3,98
	C8-390.58-50120	120	BT50 AD	C8	5,82
	C8-390.369-50070	70	BT50 B	C8	3,94
	C8-390.558-50070	70	BT TF50 AD	C8	4,02

	Designation	LF	Taper	Capto size	KG
Extension	C8-391.01-80100A	100	C8	C8	3,62
	C8-391.01-80125A	125	C8	C8	4,54

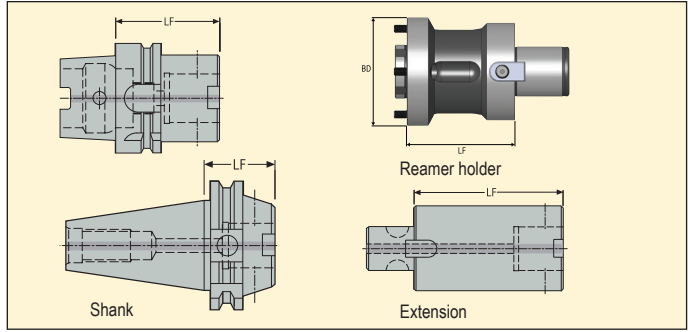
Graflex® shank for Ø 119,5-154,499 mm



	Designation	LF	Custom design		Taper	BD	Assembly screw 	
			LF min	LF max				
Reamer holders	HF100-100-G7	100	-	-	G7	100	4 pieces CHC M8X30	5,12
	HF100...HSKA80	-	100	238	HSK-A80			
	HF100...HSKA100	-	100	238	HSK-A100			
	HF100...DIN6987/50	-	100	238	DIN50 ADB			
	HF100...BT50	-	100	238	BT50 ADB			

Shanks and extensions for HF100-100-G7 (see Seco Tooling Systems for more details).

	Designation	LF	Taper	Graflex size	
Shank	EM93064014685	85	HSK-A100	G7	3,99
	EM930640146160	160	HSK-A100	G7	7,67
	EM930640146240	-	HSK-A100	G7	11,58
	EM34714014650	50	DIN50 ADB	G7	3,228
	EM347140146120	120	DIN50 ADB	G7	6,48
	EM347140146200	200	DIN50 ADB	G7	10,33
	EM34164014665	65	BT50 ADB	G7	4,3
	EM341640146120	120	BT50 ADB	G7	6,8
	EM341640146200	200	BT50 ADB	G7	10,7

	Designation	LF	Taper	Graflex size	
Extension	M402770	60	G7	G7	2,84
	M402771	90	G7	G7	4,3
	M402772	120	G7	G7	5,8

Custom design – No waiting for quotation – Short delivery time

Custom Design is also available for Xfix reamers and tool holders.

You can now quote for your own intermediate Ø reamer and tailor made Xfix tool holder using the Seco Custom Design software.

Easy to use concept: Just indicate component min/max Ø or use ISO tolerance system available in the software.

Xfix head designation is created automatically.

Custom Design gives you a number of advantages:

- No waiting for quotation! Price and delivery time is available instantly!
- Directly visualize your needs. No risk for misunderstandings
- Short delivery time

CUSTOM DESIGN

Version 1.7.9.6

Reaming >> Xfix >> Adapter HF32 (Ø39.5/59.499 - Ø1.5551"/2.3424")
Test mode (Exit) Seco mode Feedback

Back
Start Page
Login
English

Print this page

Step 1: Tool Specification

Step 2: Request for Quotation

Inch:

	Min	Max	
-			Stocked standard program
Tolerance			Custom
Dc min Xfix	39.5	59.48	40
Dc max Xfix	40.016	40.1	40.02
L3s max			260
Adapter size			HF32
Shank type			DIN50ADE
L3s	0	260	250

	Number
Graflex Adapter HF32-050-G3	1
Standard shank EM3471 401 18100	1
Graflex extensions M402 330	1
Graflex extensions M402 331	1
Number of all standard componant	4
Real total length A of Xfix set	293
Maximum total weight of Xfix set in KG	4.7

Note CHECK MAXIMUM TOOL WEIGHT ACCEPTABLE IN THE MACHINE

Previous
Request quotation

Designation

Delivery Time

Quantity: Send request

Cutting data – LNEG...EB45

SMG		a _p (Ø)	f				v _c		
			z=3	z=5	z=7	z=9	RX2000	CF	RX1500
P1	LNEG1003-EB45	0,15-0,25	0,15-0,45	0,25-0,75	0,25-1,05	0,45-1,35	120 (80-200)	180 (120-250)	220 (120-300)
P2	LNEG1003-EB45	0,15-0,25	0,15-0,45	0,25-0,75	0,25-1,05	0,45-1,35	120 (80-200)	180 (120-250)	220 (120-300)
P3	LNEG1003-EB45	0,15-0,25	0,15-0,45	0,25-0,75	0,25-1,05	0,45-1,35	120 (80-200)	180 (120-250)	220 (120-300)
P4	LNEG1003-EB45	0,15-0,25	0,15-0,45	0,25-0,75	0,25-1,05	0,45-1,35	60 (40-120)	80 (60-150)	100 (80-200)
P5	LNEG1003-EB45	0,15-0,25	0,15-0,45	0,25-0,75	0,25-1,05	0,45-1,35	60 (40-120)	80 (60-150)	100 (80-200)
P6	LNEG1003-EB45	0,15-0,25	0,15-0,45	0,25-0,75	0,25-1,05	0,45-1,35	60 (40-120)	80 (60-150)	100 (80-200)
P7	LNEG1003-EB45	0,15-0,25	0,15-0,45	0,25-0,75	0,25-1,05	0,45-1,35	60 (40-120)	80 (60-150)	100 (80-200)
P8	LNEG1003-EB45	0,15-0,25	0,15-0,45	0,25-0,75	0,25-1,05	0,45-1,35	40 (30-70)	60 (50-100)	80 (60-120)
P11	LNEG1003-EB45	0,15-0,25	0,15-0,45	0,25-0,75	0,25-1,05	0,45-1,35	40 (30-70)	60 (50-100)	80 (60-120)
P12	LNEG1003-EB45	0,15-0,25	0,15-0,45	0,25-0,75	0,25-1,05	0,45-1,35	30 (25-55)	45 (40-80)	65 (45-95)
M1	LNEG1003-EB45	0,10-0,20	0,15-0,30	0,25-0,50	0,35-0,70	0,45-0,90	35 (25-60)	-	-
M2	LNEG1003-EB45	0,10-0,20	0,15-0,30	0,25-0,50	0,35-0,70	0,45-0,90	35 (25-60)	-	-
M3	LNEG1003-EB45	0,10-0,20	0,15-0,30	0,25-0,50	0,35-0,70	0,45-0,90	35 (25-60)	-	-
M4	LNEG1003-EB45	0,10-0,20	0,15-0,30	0,25-0,50	0,35-0,70	0,45-0,90	25 (20-50)	-	-
M5	LNEG1003-EB45	0,10-0,20	0,15-0,30	0,25-0,50	0,35-0,70	0,45-0,90	25 (20-50)	-	-
K1	LNEG1003-EB45	0,20-0,50	0,15-0,45	0,25-0,75	0,25-1,05	0,45-1,35	100 (60-200)	-	220 (150-300)
K2	LNEG1003-EB45	0,20-0,50	0,15-0,45	0,25-0,75	0,25-1,05	0,45-1,35	50 (35-80)	-	70 (50-120)
K3	LNEG1003-EB45	0,20-0,50	0,15-0,45	0,25-0,75	0,25-1,05	0,45-1,35	100 (60-200)	-	220 (150-300)
K4	LNEG1003-EB45	0,20-0,50	0,15-0,45	0,25-0,75	0,25-1,05	0,45-1,35	70 (50-120)	100 (60-120)	150 (110-200)
K5	LNEG1003-EB45	0,20-0,50	0,15-0,45	0,25-0,75	0,25-1,05	0,45-1,35	70 (50-120)	100 (60-120)	150 (110-200)
K6	LNEG1003-EB45	0,20-0,50	0,15-0,45	0,25-0,75	0,25-1,05	0,45-1,35	100 (60-200)	-	220 (150-300)
K7	LNEG1003-EB45	0,20-0,50	0,15-0,45	0,25-0,75	0,25-1,05	0,45-1,35	100 (60-200)	-	220 (150-300)
H3	LNEG1003-EB45	0,10-0,20	0,1-0,25	0,15-0,40	0,25-0,5	0,30-0,7	20 (10-30)	-	-
H5	LNEG1003-EB45	0,10-0,20	0,1-0,25	0,15-0,40	0,25-0,5	0,30-0,7	20 (10-30)	-	-
H7	LNEG1003-EB45	0,10-0,20	0,1-0,25	0,15-0,40	0,25-0,5	0,30-0,7	20 (10-30)	-	-
H8	LNEG1003-EB45	0,10-0,20	0,1-0,25	0,15-0,40	0,25-0,5	0,30-0,7	20 (10-30)	-	-
H11	LNEG1003-EB45	0,10-0,20	0,1-0,25	0,15-0,40	0,25-0,5	0,30-0,7	20 (10-30)	-	-
H12	LNEG1003-EB45	0,10-0,20	0,1-0,25	0,15-0,40	0,25-0,5	0,30-0,7	20 (10-30)	-	-
H21	LNEG1003-EB45	0,10-0,20	0,1-0,25	0,15-0,40	0,25-0,5	0,30-0,7	20 (10-30)	-	-
H31	LNEG1003-EB45	0,10-0,20	0,1-0,25	0,15-0,40	0,25-0,5	0,30-0,7	20 (10-30)	-	-

Cutting data – LNEG...EB845

SMG		a _p (Ø)	f				v _c
			z=3	z=5	z=7	z=9	RX2000
P1	LNEG1003-EB845	0,15-0,25	0,15-0,60	0,25-1	0,35-1,4	0,45-1,80	120 (80-200)
P2	LNEG1003-EB845	0,15-0,25	0,15-0,60	0,25-1	0,35-1,4	0,45-1,80	120 (80-200)
P3	LNEG1003-EB845	0,15-0,25	0,15-0,60	0,25-1	0,35-1,4	0,45-1,80	120 (80-200)
P4	LNEG1003-EB845	0,15-0,25	0,15-0,60	0,25-1	0,35-1,4	0,45-1,80	60 (40-120)
P5	LNEG1003-EB845	0,15-0,25	0,15-0,60	0,25-1	0,35-1,4	0,45-1,80	60 (40-120)
P6	LNEG1003-EB845	0,15-0,25	0,15-0,60	0,25-1	0,35-1,4	0,45-1,80	60 (40-120)
P7	LNEG1003-EB845	0,15-0,25	0,15-0,60	0,25-1	0,35-1,4	0,45-1,80	60 (40-120)
P8	LNEG1003-EB845	0,15-0,25	0,15-0,60	0,25-1	0,35-1,4	0,45-1,80	40 (30-70)
P11	LNEG1003-EB845	0,15-0,25	0,15-0,60	0,25-1	0,35-1,4	0,45-1,80	40 (30-70)
P12	LNEG1003-EB845	0,15-0,25	0,15-0,60	0,25-1	0,35-1,4	0,45-1,80	30 (25-55)
M1	LNEG1003-EB845	0,10-0,20	0,15-0,45	0,25-0,75	0,25-1,05	0,45-1,35	35 (25-60)
M2	LNEG1003-EB845	0,10-0,20	0,15-0,45	0,25-0,75	0,25-1,05	0,45-1,35	35 (25-60)
M3	LNEG1003-EB845	0,10-0,20	0,15-0,45	0,25-0,75	0,25-1,05	0,45-1,35	35 (25-60)
M4	LNEG1003-EB845	0,10-0,20	0,15-0,45	0,25-0,75	0,25-1,05	0,45-1,35	25 (20-50)
M5	LNEG1003-EB845	0,10-0,20	0,15-0,45	0,25-0,75	0,25-1,05	0,45-1,35	25 (20-50)
K1	LNEG1003-EB845	0,20-0,50	0,15-0,60	0,25-1	0,35-1,4	0,45-1,80	100 (60-200)
K2	LNEG1003-EB845	0,20-0,50	0,15-0,60	0,25-1	0,35-1,4	0,45-1,80	50 (35-80)
K3	LNEG1003-EB845	0,20-0,50	0,15-0,60	0,25-1	0,35-1,4	0,45-1,80	100 (60-200)
K4	LNEG1003-EB845	0,20-0,50	0,15-0,60	0,25-1	0,35-1,4	0,45-1,80	70 (50-120)
K5	LNEG1003-EB845	0,20-0,50	0,15-0,60	0,25-1	0,35-1,4	0,45-1,80	70 (50-120)
K6	LNEG1003-EB845	0,20-0,50	0,15-0,60	0,25-1	0,35-1,4	0,45-1,80	100 (60-200)
K7	LNEG1003-EB845	0,20-0,50	0,15-0,60	0,25-1	0,35-1,4	0,45-1,80	100 (60-200)

SMG = Seco material group

a_p = mm

f = mm/rev

v_c = m/min

All cutting data are start values

Cutting data – LNEG...-EB1570

SMG		a _p (Ø)	f				v _c	
			z=3	z=5	z=7	z=9	RX2000	
P4	LNEG1005-EB1570	0,15-0,25	0,15-0,45	0,25-0,75	0,25-1,05	0,45-1,35	60 (40-120)	
P5	LNEG1005-EB1570	0,15-0,25	0,15-0,45	0,25-0,75	0,25-1,05	0,45-1,35	60 (40-120)	
P6	LNEG1005-EB1570	0,15-0,25	0,15-0,45	0,25-0,75	0,25-1,05	0,45-1,35	60 (40-120)	
P7	LNEG1005-EB1570	0,15-0,25	0,15-0,45	0,25-0,75	0,25-1,05	0,45-1,35	60 (40-120)	
P8	LNEG1005-EB1570	0,15-0,25	0,15-0,45	0,25-0,75	0,25-1,05	0,45-1,35	40 (30-70)	
P11	LNEG1005-EB1570	0,15-0,25	0,15-0,45	0,25-0,75	0,25-1,05	0,45-1,35	40 (30-70)	
P12	LNEG1005-EB1570	0,15-0,25	0,15-0,45	0,25-0,75	0,25-1,05	0,45-1,35	30 (25-55)	
K1	LNEG1005-EB1570	0,20-0,50	0,15-0,45	0,25-0,75	0,25-1,05	0,45-1,35	100 (60-200)	
K2	LNEG1005-EB1570	0,20-0,50	0,15-0,45	0,25-0,75	0,25-1,05	0,45-1,35	50 (35-80)	
K3	LNEG1005-EB1570	0,20-0,50	0,15-0,45	0,25-0,75	0,25-1,05	0,45-1,35	100 (60-200)	
K4	LNEG1005-EB1570	0,20-0,50	0,15-0,45	0,25-0,75	0,25-1,05	0,45-1,35	70 (50-120)	
K5	LNEG1005-EB1570	0,20-0,50	0,15-0,45	0,25-0,75	0,25-1,05	0,45-1,35	70 (50-120)	
K6	LNEG1005-EB1570	0,20-0,50	0,15-0,45	0,25-0,75	0,25-1,05	0,45-1,35	100 (60-200)	
K7	LNEG1005-EB1570	0,20-0,50	0,15-0,45	0,25-0,75	0,25-1,05	0,45-1,35	100 (60-200)	

Cutting data – RNAX...-EB45

SMG		a _p (Ø)	f				v _c	
			z=3	z=5	z=6	z=9	RX2000	RX1500
K1	RNAX1005-EB45	0,20-0,50	0,15-0,45	0,25-0,75	0,25-1,05	0,45-1,35	100 (60-200)	220 (150-300)
K2	RNAX1005-EB45	0,20-0,50	0,15-0,45	0,25-0,75	0,25-1,05	0,45-1,35	50 (35-80)	70 (50-120)
K3	RNAX1005-EB45	0,20-0,50	0,15-0,45	0,25-0,75	0,25-1,05	0,45-1,35	100 (60-200)	220 (150-300)
K4	RNAX1005-EB45	0,20-0,50	0,15-0,45	0,25-0,75	0,25-1,05	0,45-1,35	70 (50-120)	150 (110-200)
K5	RNAX1005-EB45	0,20-0,50	0,15-0,45	0,25-0,75	0,25-1,05	0,45-1,35	70 (50-120)	150 (110-200)
K6	RNAX1005-EB45	0,20-0,50	0,15-0,45	0,25-0,75	0,25-1,05	0,45-1,35	100 (60-200)	220 (150-300)
K7	RNAX1005-EB45	0,20-0,50	0,15-0,45	0,25-0,75	0,25-1,05	0,45-1,35	100 (60-200)	220 (150-300)

Cutting data – RNAX...-EB845

SMG		a _p (Ø)	f				v _c	
			z=3	z=5	z=6	z=9	RX2000	RX1500
K1	RNAX1005-EB845	0,20-0,50	0,15-0,60	0,25-1	0,35-1,4	0,45-1,80	100 (60-200)	220 (150-300)
K2	RNAX1005-EB845	0,20-0,50	0,15-0,60	0,25-1	0,35-1,4	0,45-1,80	50 (35-80)	70 (50-120)
K3	RNAX1005-EB845	0,20-0,50	0,15-0,60	0,25-1	0,35-1,4	0,45-1,80	100 (60-200)	220 (150-300)
K4	RNAX1005-EB845	0,20-0,50	0,15-0,60	0,25-1	0,35-1,4	0,45-1,80	70 (50-120)	150 (110-200)
K5	RNAX1005-EB845	0,20-0,50	0,15-0,60	0,25-1	0,35-1,4	0,45-1,80	70 (50-120)	150 (110-200)
K6	RNAX1005-EB845	0,20-0,50	0,15-0,60	0,25-1	0,35-1,4	0,45-1,80	100 (60-200)	220 (150-300)
K7	RNAX1005-EB845	0,20-0,50	0,15-0,60	0,25-1	0,35-1,4	0,45-1,80	100 (60-200)	220 (150-300)

Cutting data – RNAX...-EB1570

SMG		a _p (Ø)	f				v _c	
			z=3	z=5	z=6	z=9	RX2000	RX1500
K1	RNAX1005-EB1570	0,20-0,50	0,15-0,45	0,25-0,75	0,25-1,05	0,45-1,35	100 (60-200)	220 (150-300)
K2	RNAX1005-EB1570	0,20-0,50	0,15-0,45	0,25-0,75	0,25-1,05	0,45-1,35	50 (35-80)	70 (50-120)
K3	RNAX1005-EB1570	0,20-0,50	0,15-0,45	0,25-0,75	0,25-1,05	0,45-1,35	100 (60-200)	220 (150-300)
K4	RNAX1005-EB1570	0,20-0,50	0,15-0,45	0,25-0,75	0,25-1,05	0,45-1,35	70 (50-120)	150 (110-200)
K5	RNAX1005-EB1570	0,20-0,50	0,15-0,45	0,25-0,75	0,25-1,05	0,45-1,35	70 (50-120)	150 (110-200)
K6	RNAX1005-EB1570	0,20-0,50	0,15-0,45	0,25-0,75	0,25-1,05	0,45-1,35	100 (60-200)	220 (150-300)
K7	RNAX1005-EB1570	0,20-0,50	0,15-0,45	0,25-0,75	0,25-1,05	0,45-1,35	100 (60-200)	220 (150-300)

SMG = Seco material group

a_p = mm

f = mm/rev

v_c = m/min

All cutting data are start values

Adjusting instructions

1

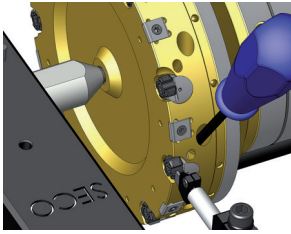

- Loosen cartridge clamping screw
- Index or replace insert
- Unclamp adjusting screw by 1/4 of a turn and push cartridge back
- Gently re-clamp cartridge clamping screw (0,5 Nm approx)

Cartridge clamping screw
Adjusting screw



2

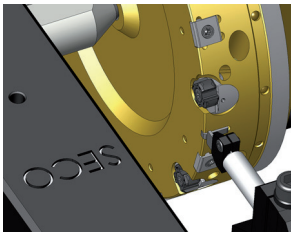

- Set clock to "zero" on reference pad.
- Make sure measuring point is positioned after the lead angle.

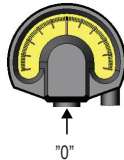

"0"

Pre-loaded guiding pad
Reference pad for adjustment

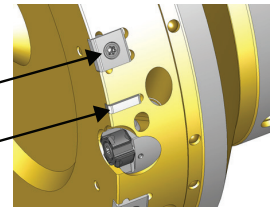

3

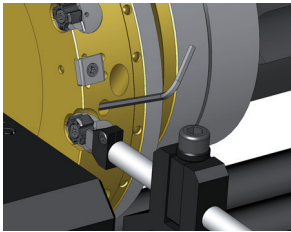

- Set insert 0,025 mm above reference pad using adjusting screw
- Repeat adjusting process for all inserts



+ 0,025 mm above reference pad

Adjusting screw



4

- Final clamp cartridge clamping screw (2 Nm).

Cartridge clamping screw



Note: If the required diameter is exceeded during adjustment, start again from the beginning to eliminate backlash on adjustment screws.

Adjusting instructions, adapter

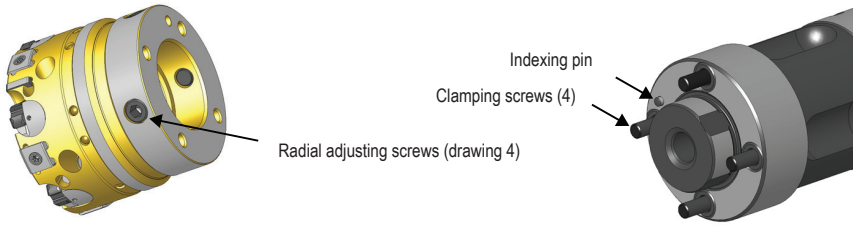

1. Assembly

- Thoroughly clean flange contact surface.
- Loosen 4 radial adjusting screws so they do not interfere for assembly.
- Put reaming head onto adapter (indexing pin) and tighten the 4 clamping screws.

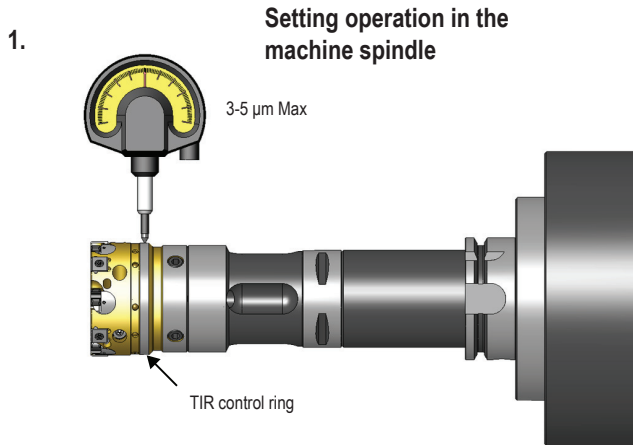

2. Clamping screws

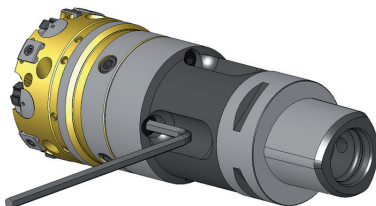

3. Radial adjusting screws (drawing 4)

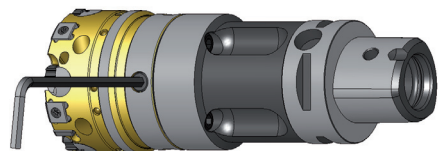

2. Setting

- Mount tool in the machine spindle.
- Place µm clock as shown in (drawing 2).
- Unlock spindle so it can rotate freely by hand.
- Start run-out correction using 4 adjusting screws (drawing 3).
- Max run-out 5 µm.
- When run-out values get lower than 10 µm, proceed to final clamping (drawing 1) see clamping torque table for torque recommended values.
- Finalize run-out adjustment (Max 5 µm).

Clamping torque table

Diameters	Adapter size	Clamping screw	Clamping torque Nm
39,5-59,499	HF32	CHC M3 x 16	2,7
59,5-84,499	HF55	CHC M5 x 25	5,7
84,5-119,499	HF80	CHC M6 x 25	9,8
119,5-154,499	HF100	CHC M8 x 30	24

Setting fixture – Single clock fixtures

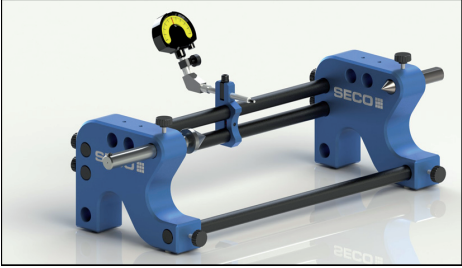

SF-210340-C160: Ordering and Part No. 02885391

- Horizontal stand
- First choice for Xfix reamers
- 1 clock
- Maximum tool \varnothing : 210 mm
- Maximum tool length: 340 mm
- Additional \varnothing 57 mm spring centre for HSK 63/80/100 and Capto C8

Centre point SSC5700 included in delivery

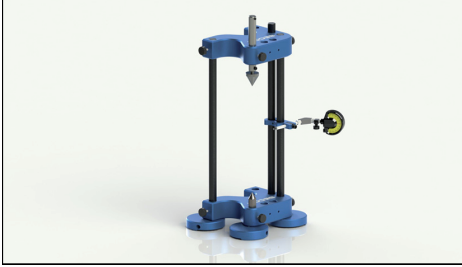

SF-210290V-C160: Ordering and Part No. 02885392

- Vertical stand
- First choice for Xfix reamers
- Maximum tool \varnothing : 210 mm
- Maximum tool length: 290 mm
- Additional \varnothing 57 mm spring centre for HSK 63/80/100 and Capto C8

Centre point SSC5700 included in delivery

Possibilities for multi-clock set up refer to setting fixture chapter page 360, 380-385 for more details

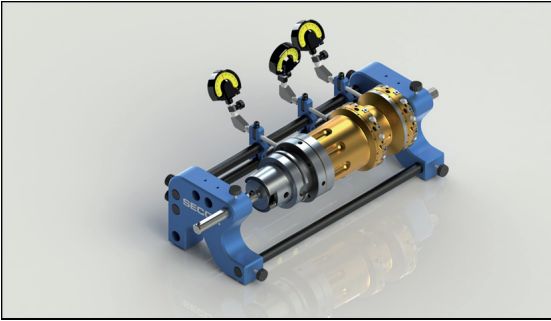

Tooling overview



Diameter	Max dia/length ratio
39,5-59,499	6,5 x D
59,5-84,499	4,5 x D
84,5-119,499	3,3 x D
119,5-154,499	2,5 x D

Note: For diameters > 100 mm or L > 3 x D check max tool weight acceptable in the machine.

Rotating applications

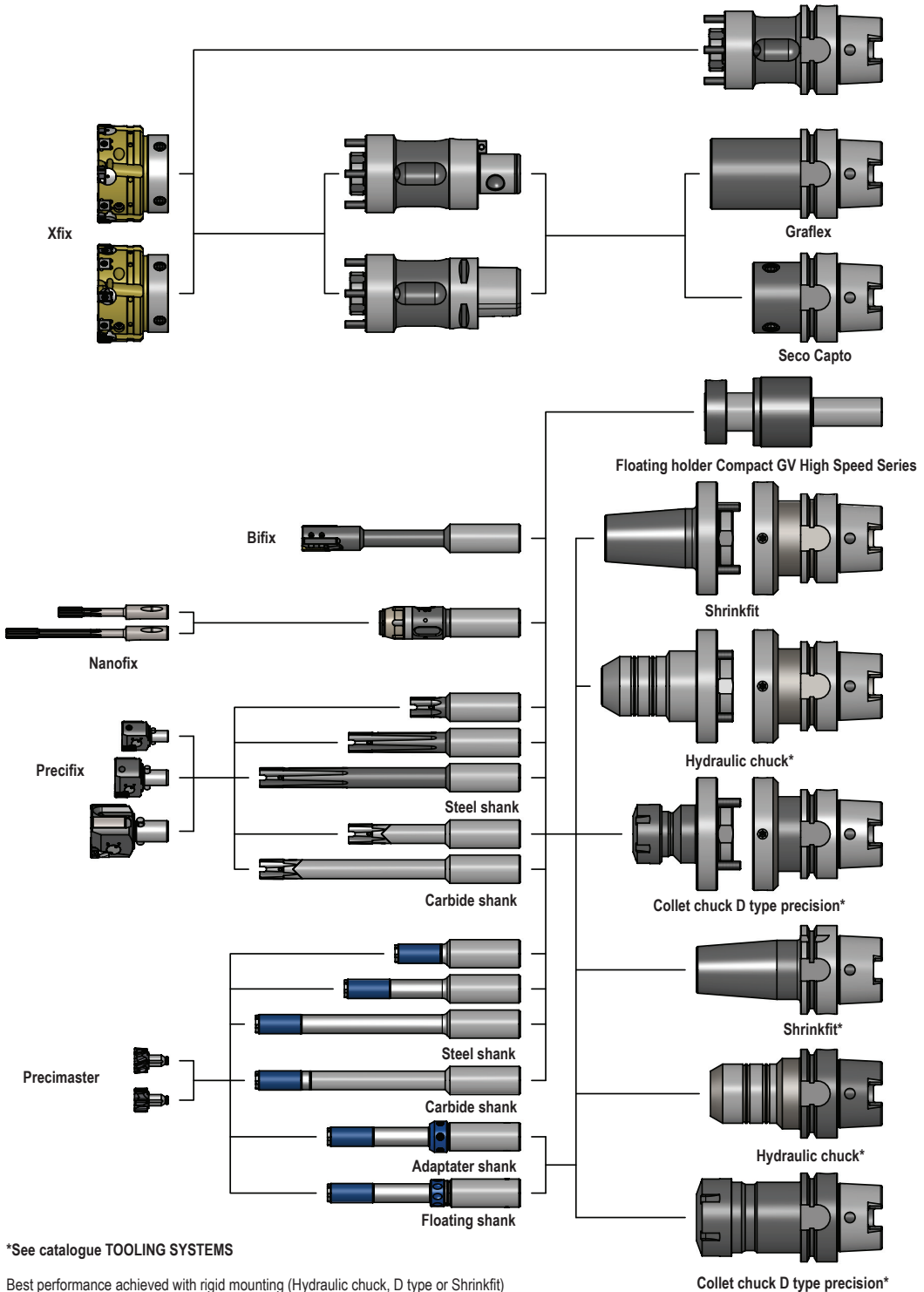

*See catalogue TOOLING SYSTEMS

Best performance achieved with rigid mounting (Hydraulic chuck, D type or Shrinkfit)

Static applications

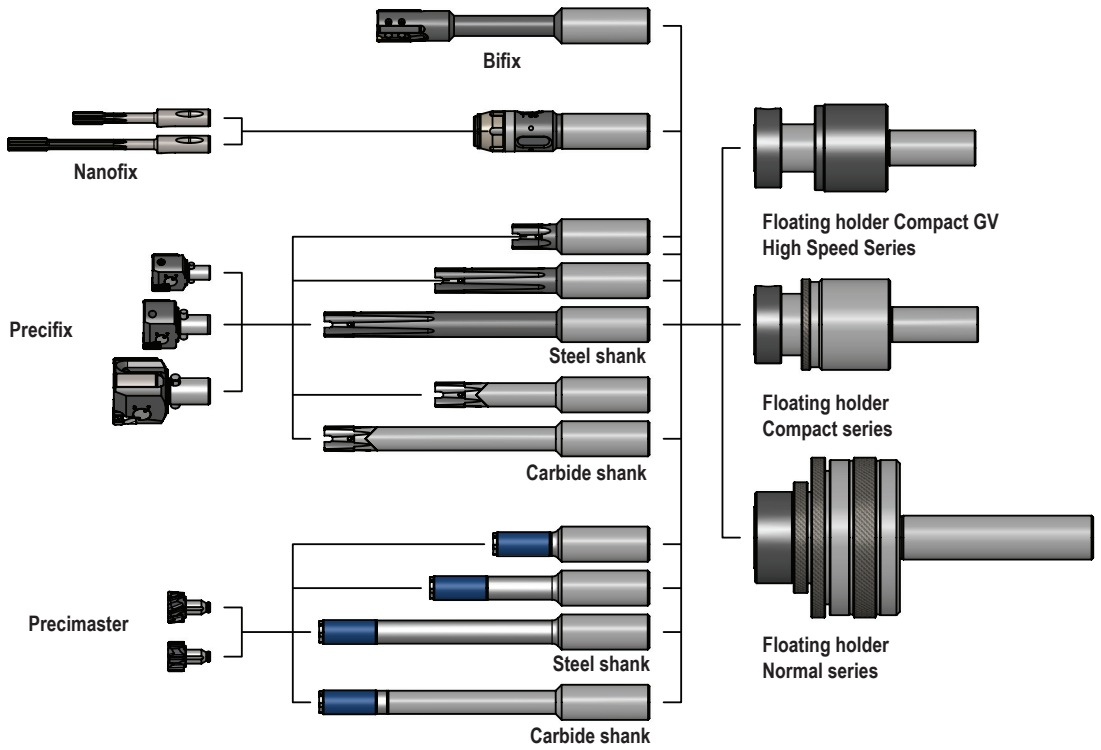

Back end HSK-A

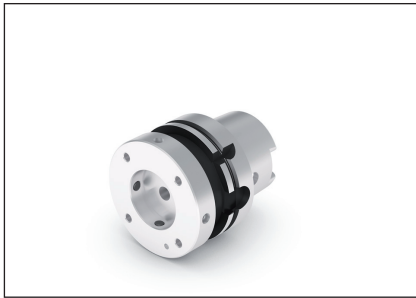

- Note: Coolant tube and screws included in delivery

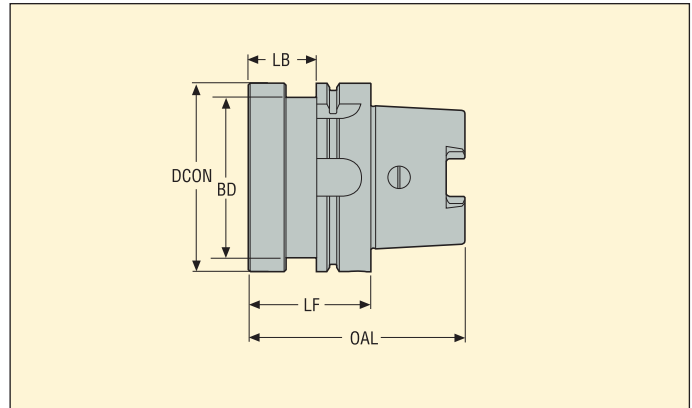

Taper	Ordering and Product No.	Designation	Dimensions in mm					 KG
			DCON	BD	LB	LF	OAL	
HSK-A 40	02836564	SAH-2340540001	60	34	35	55	75	0,80
HSK-A 50	02836566	SAH-2340550001	60	42	34	60	85	0,95
	02836567	SAH-2340550003	70	42	34	60	85	1,00
	02836573	SAH-2340550002	80	42	34	60	85	1,20
HSK-A 63	02836574	SAH-2340563001	60	53	34	60	92	1,20
	02836575	SAH-2340563003	70	53	34	60	92	1,30
	02836576	SAH-2340563002	80	53	34	60	92	1,40
	02836577	SAH-2340563004	100	53	39	65	97	1,95
HSK-A 80	02836655	SAH-2340580001	60	60	24	50	90	1,40
	02836657	SAH-2340580003	70	67	34	60	100	1,50
	02836658	SAH-2340580002	80	67	34	60	100	1,60
	02836660	SAH-2340580004	100	67	39	65	105	2,20
HSK-A 100	02836663	SAH-23405100001	60	60	26	55	105	2,50
	02836664	SAH-23405100007	70	70	26	55	105	2,80
	02836665	SAH-23405100002	80	80	26	55	105	2,90
	02836666	SAH-23405100003	100	85	36	65	115	3,50

Back end DIN 69871

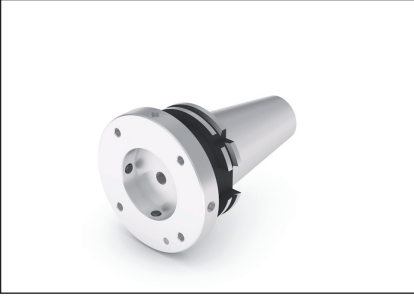

• Note: Screws included in delivery

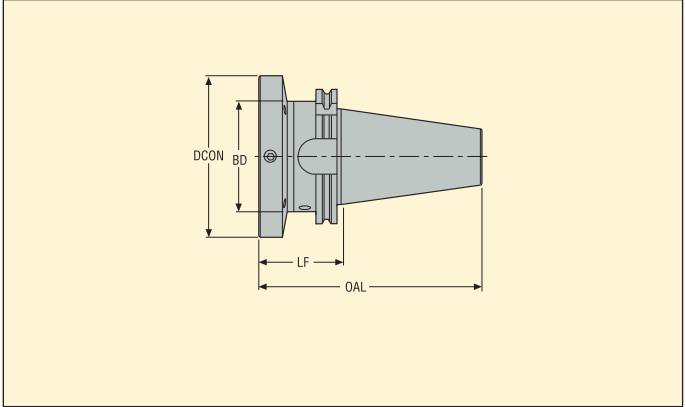

Taper	Ordering and Product No.	Designation	Dimensions in mm				KG
			DCON	BD	LF	OAL	
DIN40 ADB	02836683	SAH-2340640201	60	50	50	118,4	1,1
	02836684	SAH-2340640204	70	50	50	118,4	1,2
	02836685	SAH-2340640202	80	50	55	123,4	1,5
	02836686	SAH-2340640203	100	50	60	128,4	2,3
DIN50 ADB	02836687	SAH-2340650201	60	63	50	151,8	3,1
	02836688	SAH-2340650206	70	63	50	151,8	3,3
	02836690	SAH-2340650202	80	63	50	151,8	3,6
	02836691	SAH-2340650203	100	63	60	161,8	4,3

Back end ANSI CAT



- Note: Screws included in delivery
- Pull-stud thread imperial

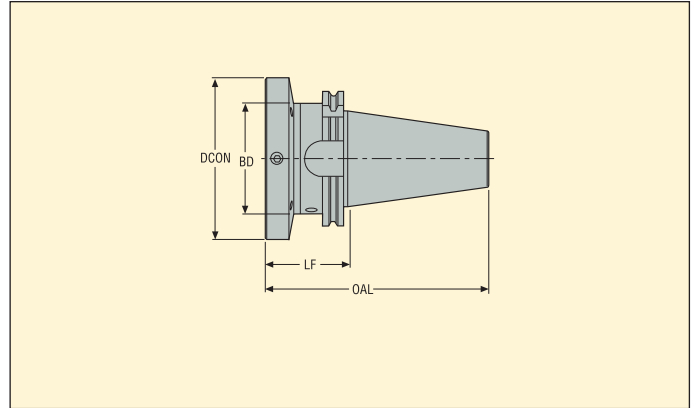



Taper	Ordering and Product No.	Designation	Dimensions in mm				KG
			DCON	BD	LF	OAL	
CAT 40	02836702	SAH-2784940202	44	80,0	55	123,4	1,5
	02836698	SAH-2784940201	60	44,45	50	118,4	1,1
	02836704	SAH-2784940203	100	44,45	60	128,4	2,3
CAT 50	02836707	SAH-2784950201	60	69,85	50	151,8	3,1
	02836708	SAH-2784950206	70	69,85	50	151,8	3,3
	02836709	SAH-2784950202	80	69,85	50	151,8	3,6
	02836710	SAH-2784950203	100	69,85	60	161,8	4,3

Back end BT

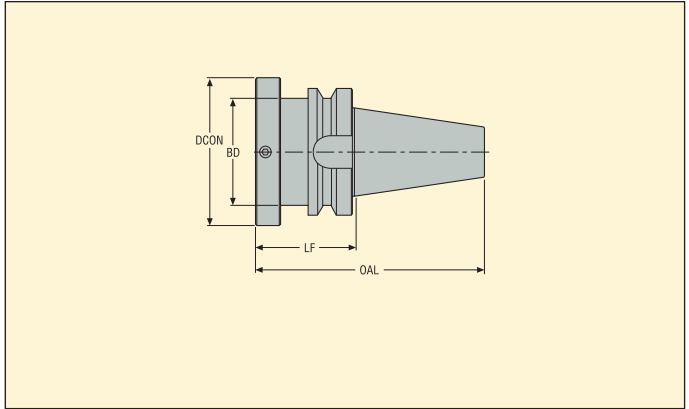

• Note: Screws included in delivery



Taper	Ordering and Product No.	Designation	Dimensions in mm				 KG
			DCON	BD	LF	OAL	
BT40 ADB	02836717	SAH-2340740001	60	50	55	120,4	1,4
	02836718	SAH-2340740004	70	50	55	120,4	1,5
	02836719	SAH-2340740002	80	50	65	130,4	1,9
	02836721	SAH-2340740003	100	50	60	125,4	2,7
BT50 ADB	02836724	SAH-2340750001	60	63	70	171,8	4,2
	02836725	SAH-2340750002	70	63	70	171,8	4,4
	02836726	SAH-2340750003	80	63	70	171,8	4,6
	02836727	SAH-2340750004	100	63	70	171,8	4,9

Front end Shrinkfit



- Note: Adjusting screws included in delivery

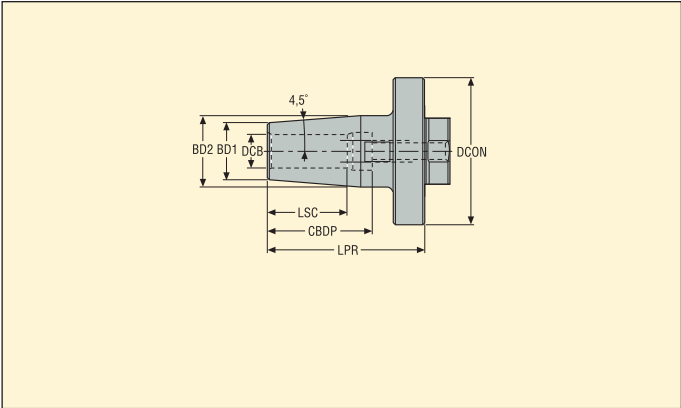

DCB	Ordering and Product No.	Designation	Dimensions in mm							KG
			DCON	BD1	BD2	DCB	LSC	CBDP	LPR	
6	02836735	SAH-2341006235	60	21	27	6	22	38	70	0,5
10	02836736	SAH-2341010237	60	24	32	10	31	43	70	0,5
12	02836737	SAH-2341012238	60	24	32	12	34	48	70	0,52
16	02836741	SAH-2341016241	70	27	34	16	39	51	75	0,7
20	02836742	SAH-2341020251	80	33	42	20	41	53	80	1,0
25	02836743	SAH-2341025260	100	44	53	25	47	59	80	2,2
32	02836744	SAH-2341032261	100	44	53	32	51	63	80	2,5

Front end ER collet chuck

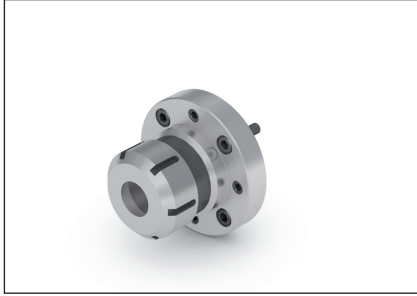

• Note: Adjusting screws included in delivery

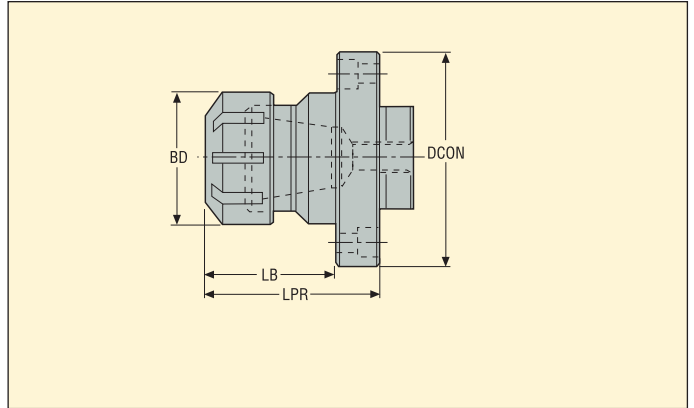

DC	Ordering and Product No.	Designation	Size	Dimensions in mm				
				DCON	LPR	BD	LB	
1-16	02836762	SAH-23412ER25254	ER25	80	60	42	45	1,0
2-20	02836763	SAH-23412ER32255	ER32	80	60	50	45	1,2
3-26	02836764	SAH-23412ER40256	ER40	100	70	63	50	1,6

Assembly instructions

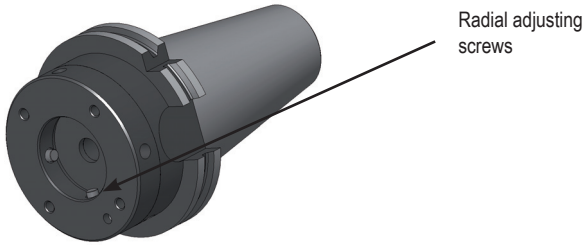

- Clean contact surface
- Make sure radial adjusting screws are not interfering with the assembly

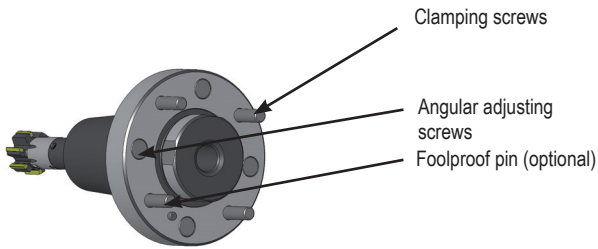

- Make sure angular adjusting screws are not interfering with the assembly

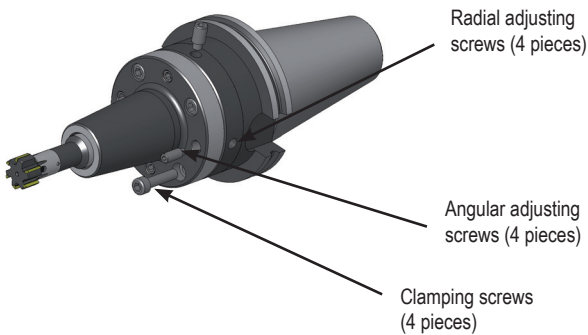

- Proceed to assembly and gently pre-clip clamping screws (x4)

Adjusting instructions

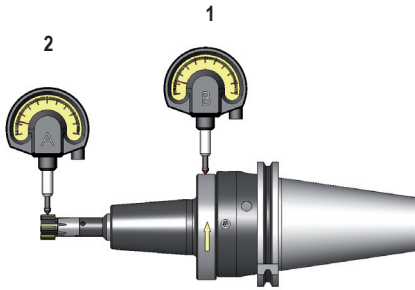

- Mount tool in the machine spindle
- Set up clock 1 as shown (clock 2 not needed at this stage)
- Rotate tool manually until lowest point is reached
- Proceed to radial run-out compensation as shown with arrow
- Check and repeat compensation if necessary

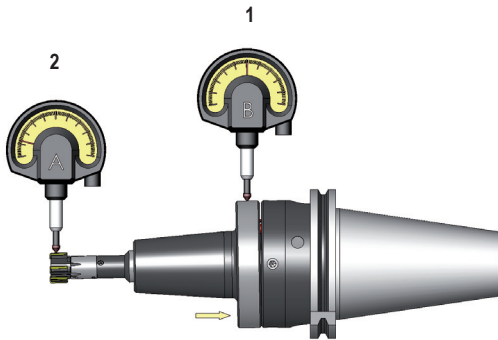

- Set up clock 2 as shown
- Rotate tool manually until lowest point is reached
- Proceed to radial run-out compensation as shown with arrow
- Check and repeat compensation if necessary

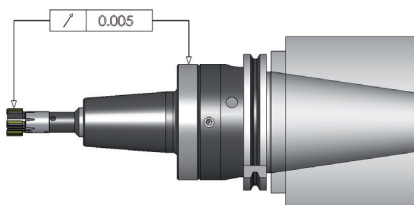

- When finished with adjustment (run-out <math>< 5 \mu\text{m}</math>) finalize clamping to secure assembly

Note:

- Adjustable adapter can be pre-set away from the machine using any tool pre-setting device available in the workshop
- Final adjusting must always be made in the machine spindle
- Micron clock must be used. It is acceptable to use one clock for both operations

Range overview

The use of a Seco floating holder is recommended

- When run-out exceeds 0.0008 inch (0.02 mm)
- For stationary tools



Compact GV high speed series

- First choice for rotating tools
- No adjustment required (factory preset)
- Rotation up to 3000 rpm depending on application
- Suitable for static applications



Compact series

- First choice for stationary tools
- Radial adjustment only
- Suitable for rotating applications – 800 rpm max



Normal series

- When both angular and radial correction is required
- Suitable for rotating applications – 800 rpm max

All floating holders for through coolant
2 types of coolant induction available

JJL: side inlet
JJ: through shank

Users manual included in delivery

Compact GV high speed series

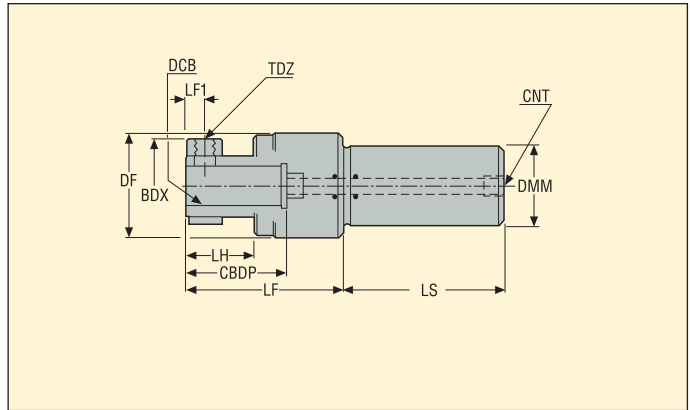

Ordering and Product No.	Designation	Dimensions in mm											mm
		DCB	DMM	LF	LS	DF	BDx	LH	CBDP	CNT	LF1	TDZ	
00088959	SFH-GV11019JJ	10	19,05	47,5	40	33,0	30	11,5	25	1/8	5,5	M6	0,2
00088945	SFH-GV11020JJ	10	20,0	47,5	40	33,0	30	11,5	25	1/8	5,5	M6	0,2
00076815	SFH-GV21619JJ	16	19,05	66,0	50	49,5	39	24,5	40	1/8	8,0	M8	0,2
00072133	SFH-GV21620JJ	16	20,0	66,0	50	49,5	39	24,5	40	1/8	8,0	M8	0,2
00076827	SFH-GV22019JJ	20	19,05	76,0	50	49,5	45	34,5	50	1/8	8,0	M8	0,2
00072134	SFH-GV22020JJ	20	20,0	76,0	50	49,5	45	34,5	50	1/8	8,0	M8	0,2
00076828	SFH-GV32525JJ	25	25,4	89,0	60	62,0	52	43,5	60	1/4	11,0	M10	0,3
00072135	SFH-GV32525MJJ	25	25,0	89,0	60	62,0	52	43,5	60	1/4	11,0	M10	0,3
00088960	SFH-GV325425JJ	25	25,4	89,0	60	62,0	52	43,5	60	1/4	11,0	M10	0,3
02602671	SFH-GV43232JJ	32	32,0	90,0	80	72,0	60	34,0	60	3/8	9,0	M10	0,3

Accessories

Designation	Reduction ring	
	DCB	DMM
SRR-BR11016	10	16
SRR-BR11216	12	16
SRR-BR11220	12	20
SRR-BR21620	16	20
SRR-BR31625	16	25
SRR-BR32025	20	25
SRR-GV42532	25	32

Compact GV high speed series with collet chuck

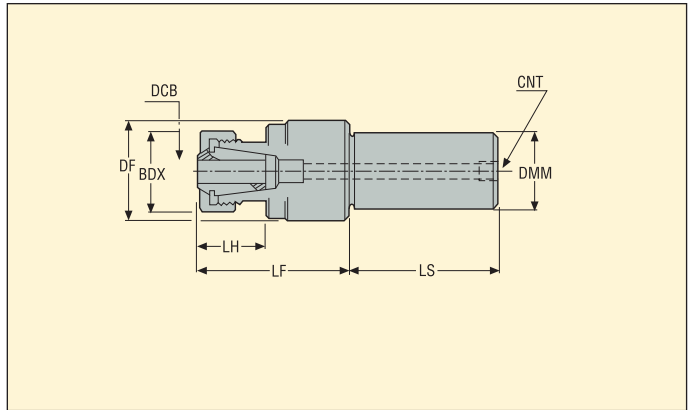

Ordering and Product No.	Designation	Dimensions in mm								
		CZC	DMM	LF	LS	DF	BDX	LH	CNT	mm
00088946	SFH-GV3BC25MJJ	ER32	25,0	80	60	62	50	35	1/4	0,3
00088961	SFH-GV3BC25JJ	ER32	25,4	80	60	62	50	35	1/4	0,3
00088962	SFH-GV4BC31JJ	ER40	31,75	94	80	72	63	39	3/8	0,3
00088947	SFH-GV4BC32JJ	ER40	32,0	94	80	72	63	39	3/8	0,3

Accessories

Designation	Size	Collet			Size	Spanner
		DCB	BD	OAL		
5880 3210	ER32	10	33	40	ER32	03B587532
5880 3212	ER32	12	33	40	ER40	03B537540
5880 3213	ER32	13	33	40	-	-
5880 3216	ER32	16	33	40	-	-
5880 3220	ER32	20	33	40	-	-
5880 4016	ER40	16	41	46	-	-
5880 4020	ER40	20	41	46	-	-
5880 4025	ER40	25	41	46	-	-
5880 4026	ER40	26	41	46	-	-

Collet and wrenches are not delivered with chucks.

Compact series

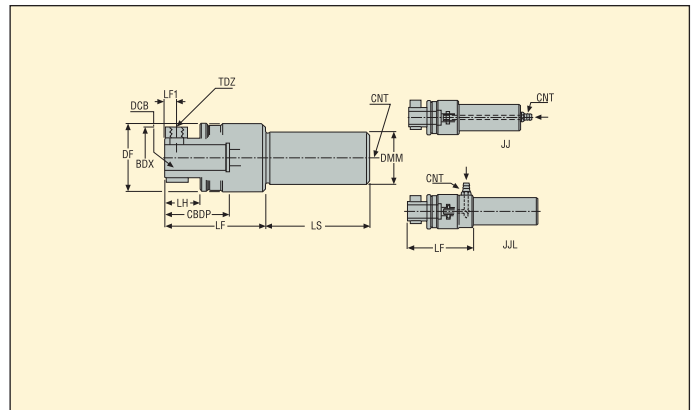

Ordering and Product No.	Designation	Dimensions in mm											mm	KG
		DCB	DMM	LF	LS	DF	BDX	LH	CBDP	CNT	LF1	TDZ		
00088963	SFH-C01019JJ	10	19,05	44,5	40	38,5	30	11	25	1/8	6	M6	1,0	1,0
00088964	SFH-C01019JLL	10	19,05	62,0	60	38,5	30	11	25	1/8	6	M6	1,0	1,0
00076829	SFH-C21619CJJ	16	19,05	67,5	50	51,5	34	17	40	1/4	8	M6	1,5	1,5
00088965	SFH-C21619JLL	16	19,05	87,0	60	51,5	34	17	40	1/4	8	M6	1,5	1,5
00076830	SFH-C22019CJJ	20	19,05	77,5	50	51,5	44	27	50	1/4	8	M8	1,5	1,5
00088966	SFH-C22019JLL	20	19,05	97,0	70	51,5	44	27	50	1/4	8	M8	1,5	1,5
00088948	SFH-C01020JJ	10	20,0	44,5	40	38,5	30	11	25	1/8	6	M6	1,0	1,0
00088949	SFH-C01020JLL	10	20,0	62,0	60	38,5	30	11	25	1/8	6	M6	1,0	1,0
00072142	SFH-C21620CJJ	16	20,0	67,5	50	51,5	34	17	40	1/4	8	M6	1,5	1,5
00088950	SFH-C21620JLL	16	20,0	87,0	60	51,5	34	17	40	1/4	8	M6	1,5	1,5
00072145	SFH-C22020CJJ	20	20,0	77,5	50	51,5	44	27	50	1/4	8	M8	1,5	1,5
00088951	SFH-C22020JLL	20	20,0	97,0	60	51,5	44	27	50	1/4	8	M8	1,5	1,5
00072149	SFH-C32525MJL	25	25,0	90,0	110	59,5	50	31	60	3/8	11	M8	1,5	1,5
00088952	SFH-C32525MJLL	25	25,0	125,0	70	59,5	50	31	60	3/8	11	M8	1,5	1,5
00076846	SFH-C32525JJ	25	25,4	90,0	110	59,5	50	31	60	3/8	11	M8	1,5	1,5
00088967	SFH-C32525JLL	25	25,4	125,0	70	59,5	50	31	60	3/8	11	M8	1,5	1,5

Accessories

Designation	Reduction ring	
	DCB	DMM
SRR-BR11016	10	16
SRR-BR11216	12	16
SRR-BR11220	12	20
SRR-BR21620	16	20
SRR-BR31625	16	25
SRR-BR32025	20	25

Hose adapter is not included in delivery.

Compact series with collet chuck

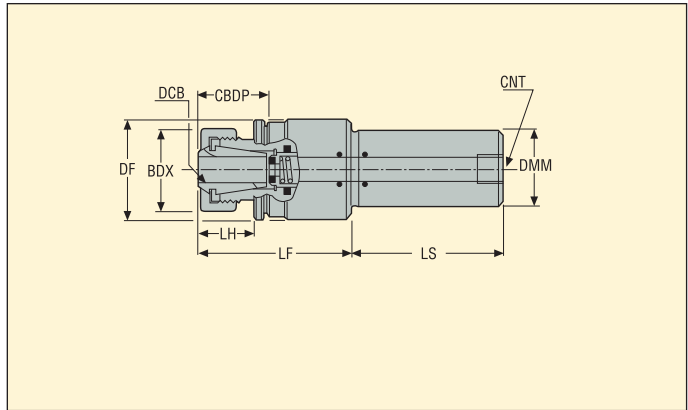

Ordering and Product No.	Designation	Dimensions in mm									
		CZC	DMM	LF	LS	DF	BDX	LH	CBDP	CNT	mm
00088953	SFH-C65BC25MCJJ	ER32	25,0	94	50	65	50	33	42	3/8	1,5
00088968	SFH-C65BC25CJJ	ER32	25,4	94	50	65	50	33	42	3/8	1,5

Accessories

Designation	Size	Collet			Size	Spanner
		DCB	BD	OAL		
5880 3210	ER32	10	33	40	ER32	03B587532
5880 3212	ER32	12	33	40	ER40	03B537540
5880 3213	ER32	13	33	40	-	-
5880 3216	ER32	16	33	40	-	-
5880 3220	ER32	20	33	40	-	-
5880 4016	ER40	16	41	46	-	-
5880 4020	ER40	20	41	46	-	-
5880 4025	ER40	25	41	46	-	-
5880 4026	ER40	26	41	46	-	-

Collets and wrenches are not delivered with chucks.

Normal series

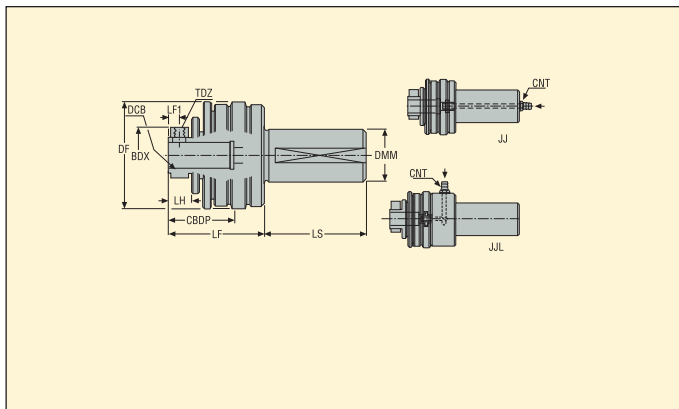

Ordering and Product No.	Designation	Dimensions in mm												mm	KG
		DCB	DMM	LF	LS	DF	BDX	LH	CBDP	CNT	LF1	TDZ			
00088969	SFH-11619JJ	16	19,05	64	50	62	34	16	40	1/4	8	M6	1 °	1,5	0,9
00088970	SFH-11619JJL	16	19,05	81	40	62	34	16	40	1/4	8	M6	1 °	1,5	1,32
00088954	SFH-11620JJ	16	20,0	64	50	62	34	16	40	1/4	8	M6	1 °	1,5	0,95
00088955	SFH-11620JJL	16	20,0	81	40	62	34	16	40	1/4	8	M6	1 °	1,5	1,34
00088971	SFH-22025JJ	20	25,4	74	65	82	44	16	50	3/8	8	M8	1 °	1,5	1,9
00088972	SFH-22025JJL	20	25,4	98	70	82	44	16	50	1/4	8	M8	1 °	1,5	2,2
00088956	SFH-22025MJJ	20	25,0	74	65	82	44	16	50	3/8	8	M8	1 °	1,5	1,9
00088957	SFH-22025MJJL	20	25,0	98	70	82	44	16	50	1/4	8	M8	1 °	1,5	2,2
00088973	SFH-32525JJ	25	25,4	83	110	91	52	22	60	3/8	11	M8	1 °	2,0	2,5
00088958	SFH-32525MJJ	25	25,0	83	110	91	52	22	60	3/8	11	M8	1 °	2,0	2,5

Accessories

Designation	Reduction ring	
	DCB	DMM
SRR-BR11016	10	16
SRR-BR11216	12	16
SRR-BR11220	12	20
SRR-BR21620	16	20
SRR-BR31625	16	25
SRR-BR32025	20	25

Hose adapter is not included in delivery.

Setting fixture – Single clock fixtures

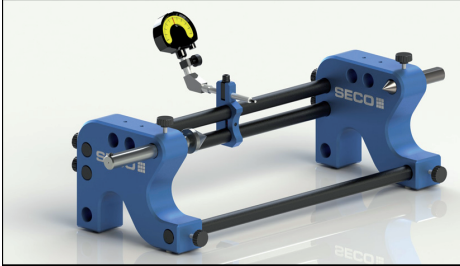

SF-210340-C160: Ordering and Part No. 02885391

- Horizontal stand
- First choice for Xfix reamers
- 1 clock
- Maximum tool Ø: 210 mm
- Maximum tool length: 340 mm
- Additional Ø 57 mm spring centre for HSK 63/80/100 and Capto C8

Centre point SSC5700 included in delivery

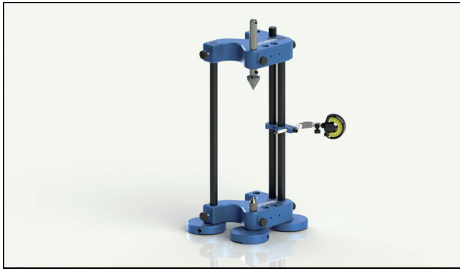

SF-210290V-C160: Ordering and Part No. 02885392

- Vertical stand
- First choice for Xfix reamers
- Maximum tool Ø: 210 mm
- Maximum tool length: 290 mm
- Additional Ø 57 mm spring centre for HSK 63/80/100 and Capto C8

Centre point SSC5700 included in delivery

Dual clock fixtures

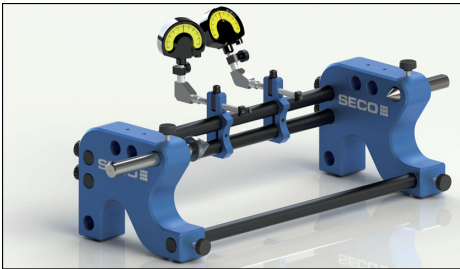

SF-210340-C160C190: Ordering and Part No. 02885393

- Horizontal stand
- First choice for Bifix reamers
- 2 clocks
- Maximum tool Ø: 210 mm
- Maximum tool length: 340 mm
- Additional Ø 57 mm spring centre for HSK 63/80/100 and Capto C8

Centre point SSC5700 included in delivery

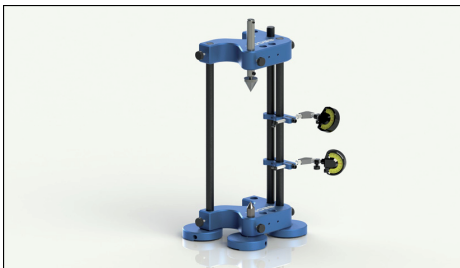

SF-210290V-C160C190: Ordering and Part No. 02885394

- Vertical stand
- First choice for Bifix reamers
- 2 clocks
- Maximum tool Ø: 210 mm
- Maximum tool length: 290 mm
- Additional Ø 57 mm spring centre for HSK 63/80/100 and Capto C8

Centre point SSC5700 included in delivery

Single clock fixtures large capacity

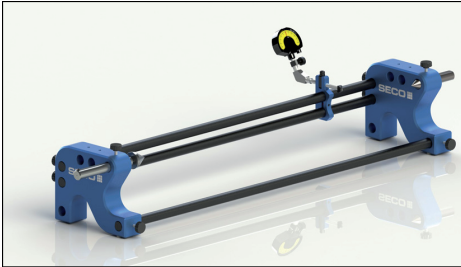

SF-210740-C160: Ordering and Part No. 02885385

- Horizontal stand
- First choice for long Xfix reamers
- 1 clock
- Maximum tool \varnothing : 210 mm
- Maximum tool length: 740 mm
- Additional \varnothing 57 mm spring centre for HSK 63/80/100 and Capto C8

Centre point SSC5700 included in delivery



SF-210690V-C160: Ordering and Part No. 02885387

- Vertical stand
- First choice for long Xfix reamers
- 1 clock
- Maximum tool \varnothing : 210 mm
- Maximum tool length: 690 mm
- Additional \varnothing 57 mm spring centre for HSK 63/80/100 and Capto C8

Centre point SSC5700 included in delivery

Dual clock fixtures large capacity

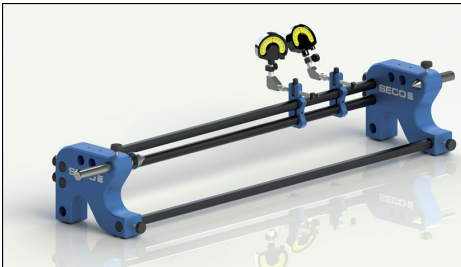

SF-210740-C160C190: Ordering and Part No. 02885388

- Horizontal stand
- First choice for long Bifix reamers
- 2 clocks
- Maximum tool \varnothing : 210 mm
- Maximum tool length: 740 mm
- Additional \varnothing 57 mm spring centre for HSK 63/80/100 and Capto C8

Centre point SSC5700 included in delivery



SF-210690V-C160C190: Ordering and Part No. 02885390

- Vertical stand
- First choice for long Bifix reamers
- 2 clocks
- Maximum tool \varnothing : 210 mm
- Maximum tool length: 690 mm
- Additional \varnothing 57 mm spring centre for HSK 63/80/100 and Capto C8

Centre point SSC5700 included in delivery

Compact setting fixtures



SF-60200-C160: Ordering and Part No. 02885395

- Horizontal stand
- First choice for \varnothing smaller than 60 mm
- 1 clock
- Maximum tool \varnothing : 60,5 mm
- Maximum tool length: 200 mm

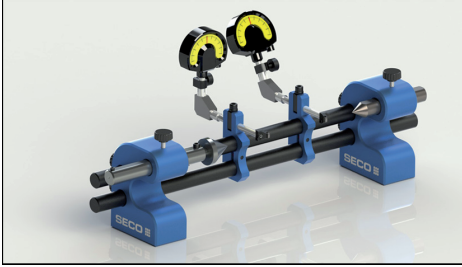

SF-60200-C160C190: Ordering and Part No. 02885396

- Horizontal stand
- First choice for \varnothing smaller than 60 mm
- 2 clocks
- Maximum tool \varnothing : 60,5 mm
- Maximum tool length: 200 mm

Additional measuring arms

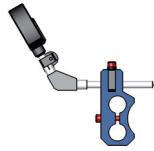

SFB-60: Ordering and Part No. 02208619

- Measuring arm 60°
- Dial gauge included in delivery
- Measuring point not included, see page 384



SFB-60 WC: Ordering and Part No. 02885754

- Measuring arm 60°
- Dial gauge not included in delivery
- Measuring point not included, see page 384

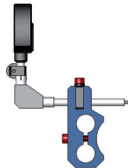
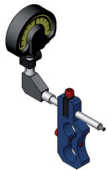

SFB-90: Ordering and Part No. 02208622

- Measuring arm 90°
- Dial gauge included in delivery
- Measuring point not included, see page 384

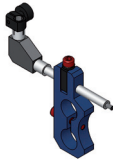

SFB-90 WC: Ordering and Part No. 02885755

- Measuring arm 90°
- Dial gauge not included in delivery
- Measuring point not included, see page 384



DG-1: Ordering and Part No. 75079579

- Dial gauge , 1 μm

Examples of multi clocks setting fixture assembly

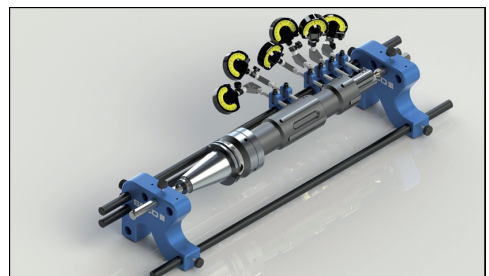
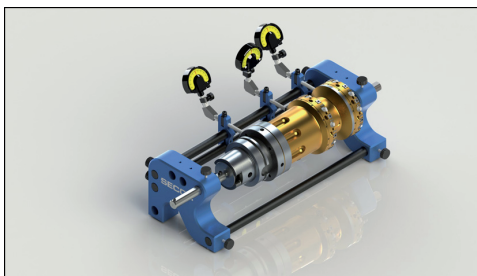

Accessories



SMES-406: Ordering and Part No. 02819156

- Measuring point for Xfix reamers
- Ø 4mm
- Carbide tipped

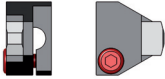

SMES-900: Ordering and Part No. 02208610

- Measuring point for Bifix & Precifix reamers
- Carbide tipped

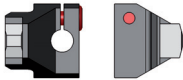

SMES-909: Ordering and Part No. 02208613

- Measuring point for Bifix & Precifix reamers
- Carbide tipped
- 9 mm offset



SMES-915: Ordering and Part No. 02208616

- Measuring point for Bifix & Precifix reamers
- Carbide tipped
- 15 mm offset

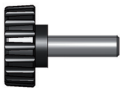

SFHS-20: Ordering and Part No. 02884025

- Hand-screw
- Suitable for the entire setting fixture range



SFVST- 100: Ordering and Part No. 02884026

- Steel stand (set of 3)
- Ø 100 mm
- Suitable to convert horizontal setting fixture to vertical position

Centre points

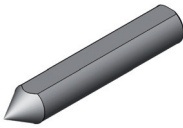

SFC-2000HM: Ordering and Part No. 02884023

- Solid carbide fixed centre point
- Ø 20 mm
- Suitable for Xfix, Precifix and Bifix range standard and special
- To be used at front end of the tool

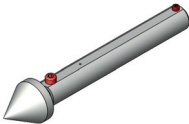

SSC-3400: Ordering and Part No. 02208617

- Spring centre point
- Ø 34 mm
- Suitable for Xfix, Precifix and Bifix range standard and special
- To be used at back end of the tool
- Not suitable for HSK63/80/100 and capto C8

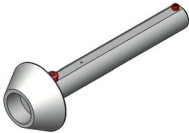





SSC5700: Ordering and Part No. 02208620



- Spring centre point
- Truncated Ø 57 mm
- Suitable for Xfix, Precifix and Bifix range standard and special
- To be used at back end of the tool
- Suitable for HSK63/80/100 and capto C8



Overview

<p>EPB 750 boring heads, rough boring Twin cutting heads, with insert holders coupling mechanism</p>  <p>Page(s) 389-401</p>	<ul style="list-style-type: none"> • High metal removal, precise hole geometry and hole position • Both symmetrical and staggered settings • Simultaneous adjustment by an insert holders coupling mechanism • With Graflex® or Seco-Capto™ connections 	<p>∅ range 18 to 205 mm IT 9/10</p>
<p>EPB 610 boring heads, rough boring Twin cutting heads</p>  <p>Page(s) 402-409</p>	<ul style="list-style-type: none"> • High metal removal, precise hole geometry and hole position • Both symmetrical and staggered settings • With Graflex® connection for Graflex® modular system • With GL or BA connection for Steadyline® vibration damping bars 	<p>∅ range 39 to 115 mm IT 9/10</p>
<p>EPB 760 boring heads, Axiabore™ type Fine boring heads, with axial tools</p>  <p>Page(s) 410-436</p>	<ul style="list-style-type: none"> • Micrometric adjustment for hole precision up to IT5 • High tool rigidity for precise hole geometry and position • Nanobore™ head for smaller diameters • Axialibrabore™ and - Axialibrabore™ Plus - are fine balanceable, HSM suitable • Multi-purpose adapter (MPA) for larger boring diameters, OD-overturning and grooving • With Graflex® or Seco-Capto™ connections 	<p>∅ range 0,3 to 108 mm + OD-overturning and face grooving IT 5/6</p>
<p>EPB 620, EPB 780 & EPB 790 boring heads, radial type Fine boring heads, with radial insert holder</p>  <p>Page(s) 437-450</p>	<ul style="list-style-type: none"> • Micrometric adjustment for hole precision up to IT5 • Precise hole geometry and position • A790 Libraflex® heads are fine balanceable, HSM suitable Insert holder clamping for highest reliability • Long bores achievable, using carbide extensions (up to 7xD) or Steadyline® bars (up to 10xD) • Also for chamfering and back-boring • With Graflex® or Seco-Capto™ connections for modular systems • With GL or BA connection for Steadyline® vibration damping bars 	<p>∅ range 15 to 205 mm IT 5/6</p>

Overview

<p>Bridge bars & Jumbo boring heads For rough and fine boring large diameters</p>  <p>Page(s) 451-468</p>	<ul style="list-style-type: none"> • Boring blocks available for rough and fine boring, OD-overturning and back-boring • Strong design for high metal removal in rough boring • Micrometric adjustment for fine boring • Optimized boring block design and Jumbo Bridge bars made from high tensile aluminium for high speeds • To be fitted onto milling cutter holders, flange mounting type 	<p>Ø range 204 to 3205 mm IT 5/6 (fine boring) or 9/10 (rough boring)+ OD-overturning IT6</p>
<p>Inserts for boring</p>  <p>Page(s) 470-479</p>	<ul style="list-style-type: none"> • For boring applications in all materials • High toughness for rough boring • Positive geometries for fine boring • Grades selected for long life 	
<p>Graflex® or Seco-Capto™ modular holding systems</p>  <p>Page(s) 480-482</p>	<ul style="list-style-type: none"> • The boring heads have a Graflex® or a Seco-Capto™ machine side connection shank enabling a full range of boring depths and diameters • Select the required Graflex® or Seco-Capto™ arbors and intermediates from the TOOLING SYSTEMS catalogue (HSK, DIN, BT, ANSI-CAT, Seco-Capto™) • Graflex® connections spare parts for boring heads are shown in that chapter 	



Overview Rough boring heads

Graflex®

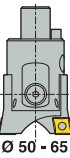
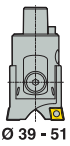

Seco-Capto™

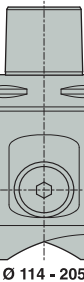
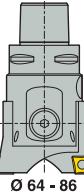
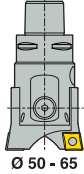
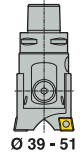

Symmetrical boring:
2 standard type A insert holders

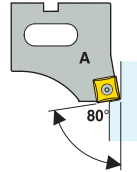
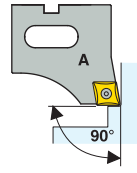
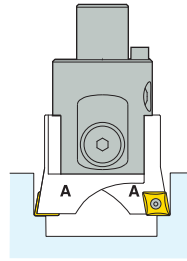

Staggered boring:
1 extended type B and 1 standard type A insert holders

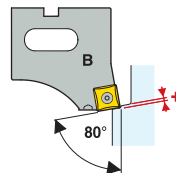
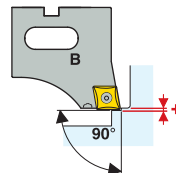
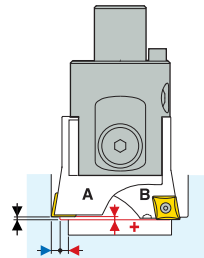

Features

Rough boring heads for bores \varnothing 18 to 205 mm

8 rough boring heads EPB 750 with Graflex® connection for bores \varnothing 18 to 205 mm

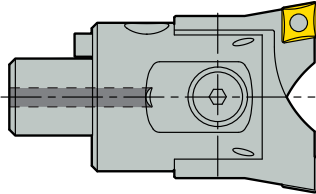

5 rough boring heads EPB 750 with Seco-Capto™ connection for bores \varnothing 39 to 205 mm

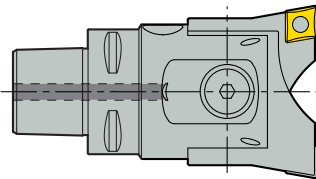

Note: The minimum bore size of the smallest Seco-Capto™ rough boring head is \varnothing 39 mm with the smallest available Seco-Capto™ C3 connection.

For \varnothing 18 to 40 mm use Graflex® boring heads with connection sizes G0 to G2 in conjunction with the appropriate Seco-Capto™/Graflex® adaptor.

This offers also boring length modularity when using additional Graflex® extensions.

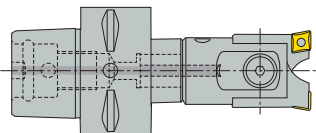

Seco-Capto™ adapter and Graflex® head: \varnothing 18 to 40 mm

Note: Features, Instructions (insert holder fitting, diameter setting, back boring instructions, troubleshooting, recommended machining conditions, maximum speeds), **suitable insert holders and suitable inserts** are similar for both types of EPB 750 rough boring heads of similar boring capacity size, regardless of connection type.

Features

A rough boring head assembly is a combination of 1 body (head) and 2 insert holders.

Simultaneous or independent adjustments of the insert holders are possible:

Simultaneous adjustment by the insert holders coupling mechanism (no coupling mechanism in the smallest head \varnothing 18 to 24 mm).

Each adjusting screw moves both insert holders simultaneously (they are gear coupled).

Diameter adjustment is possible without a presetter (1 increment = 0,1 mm on the diameter).

Independent adjustment is also possible: disengage the coupling mechanism so that each adjusting screw acts only on its insert holder.

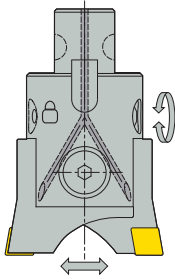

Simultaneous adjustment

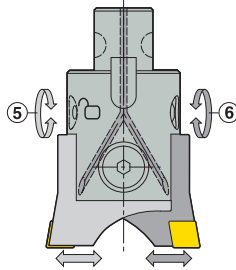

Independent adjustment

Symmetrical boring:

Symmetrical boring means both cutting edges are set on the same diameter: It requires two identical type A standard insert holders (with identical lead angle).

Staggered boring:

Staggered boring means one cutting edge is offset as a leading cutting edge operating on a smaller diameter than the second edge set on the diameter to be realised: It requires one type A standard insert holder and one type B extended insert holder, achieving the required (+) axial offset.

90° or 80° lead angle insert holders

A75...CC... and A75...CP... insert holders have a 90° lead angle for rhombic inserts: mostly suitable for blind holes and requiring less spindle torque.

A75...SC... insert holders have an 80° lead angle for square inserts: mostly suitable for through holes and heavy duty.

Angular orientation of the cutting edges according to ISO.

CC, CP, SC or CN type insert holders

A750...CC..., A750...CP... and A750...SC... insert holders are with 0° rake angle (GAMO) and 0° inclination angle (LAMS).

A750...CN... insert holders are with -6° rake angle (GAMO) and -6° inclination angle (LAMS), allowing use of 'negative' CNMM inserts and particularly multi-edges CNMG inserts with 4 cutting edges. In this case, it is particularly important to select the recommended CN inserts and to respect the recommended cutting data (see page 475). Using other inserts, e.g. with smaller effective cutting angle, and/or incorrect cutting data, could result in high cutting stresses and machine / workpiece damage.

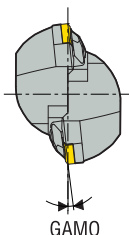

GAMO

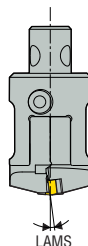

LAMS

EPB 750 – Rough boring heads

Seco-Capto™



- Symmetrical and staggered boring is possible
- Simultaneous adjustment by insert holders coupling mechanism

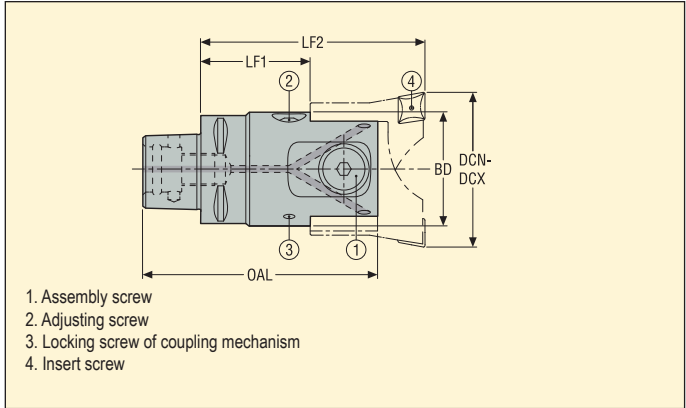

Machine side Capto size	Workpiece side Capacity DCN-DCX Ø mm	Ordering and Product No.	Designation	Simultaneous adjustment mode		Independent adjustment mode		Dimensions in mm				Max. RPM	KG
				Yes	No	Yes	No	OAL	LF1	LF2	BD		
C3	39,0-51,0	02809726	C3-391.0750-30	■		■		73,1	29,0	79,0	35,0	7500	0,28
C4	50,0-65,0	02809728	C4-391.0750-40	■		■		88,0	37,0	82,0	43,0	5700	0,52
C5	64,0-86,0	02809733	C5-391.0750-50	■		■		102,0	40,0	92,0	54,0	4500	0,94
C6	85,0-144,0	02809735	C6-391.0750-60	■		■		129,0	49,0	117,0	70,0	3500	1,88
C8	114,0-205,0	02809736	C8-391.0750-70	■		■		159,0	57,0	138,0	95,0	2500	4,14

Insert holders have to be ordered separately, see page(s) 395-399. *Without insert holder.

Spare Parts

Accessories

For head	Assembly screw	Clamp key	Driving key	Insert key	Setting key	Setting gauge
C3...30	90A75030	03HL05	T08P-3	T15P-3	H2.0-2D	CAA75030
C4...40	90A75040	03HL05	T09P-3	T15P-3	H2.5-2D	CAA75040
C5...50	90A75050	03HL06	T15P-3	T15P-3	03M03C	CAA75050
C6...60	90A75060	03HL08	T15P-3	T15P-3	H04-4	CAA75060
C8...70	90A75070	03HL10	T15P-3	T15P-3	H04-4	CAA75070

Please check availability in current price and stock-list
 Accessories not included in delivery.

Rough boring insert holders 90°, for CC.. and CP.. inserts, for EPB 750 heads



- For fitting onto heads EPB 750
- Symmetrical boring requires two standard type A insert holders
- Staggered boring requires one standard type A and one extended type B insert holders

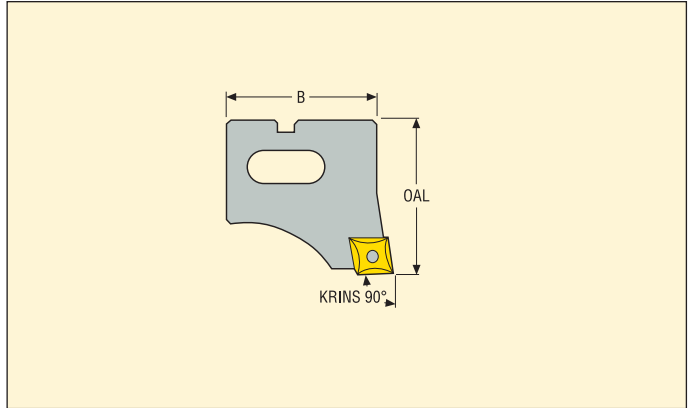

Insert holders type	For head	Capacity DCN-DCX Ø mm	Ordering and Product No.	Designation	KRINS°	Dimensions in mm		Suitable insert size	KG
						OAL	B		
Standard type A	EPB 75000	18,0-24,0	00026695	A75000CP0590	90,0	22,5	16,5	CP...0502...	0,01
	EPB 75010	23,0-31,0	00026696	A75010CC0690	90,0	26,5	21,5	CC...0602...	0,02
	EPB 75020	30,0-40,0	00026697	A75020CC0690	90,0	30,0	27,0	CC...0602...	0,04
	EPB 75030	39,0-51,0	00026698	A75030CC0990	90,0	41,0	35,0	CC...09T3...	0,08
	EPB 75040	50,0-65,0	00026699	A75040CC1290	90,0	45,0	43,0	CC...1204...	0,14
	EPB 75050	64,0-86,0	00026700	A75050CC1290	90,0	52,0	54,0	CC...1204...	0,25
	EPB 75060	85,0-115,0	00026701	A75060CC1290	90,0	68,0	70,0	CC...1204...	0,55
	EPB 75060	85,0-115,0	00030763	A75060CC1690	90,0	68,0	70,0	CC...1605...	0,55
	EPB 75060	114,0-144,0	00026702	A75065CC1290	90,0	68,0	100,0	CC...1204...	0,89
	EPB 75060	114,0-144,0	00030765	A75065CC1690	90,0	68,0	100,0	CC...1605...	0,9
	EPB 75070	114,0-160,0	00026703	A75070CC1290	90,0	81,0	95,0	CC...1204...	1,18
	EPB 75070	114,0-160,0	00030766	A75070CC1690	90,0	81,0	95,0	CC...1605...	1,18
	EPB 75070	159,0-205,0	00026704	A75075CC1290	90,0	81,0	141,0	CC...1204...	2,0
	EPB 75070	159,0-205,0	00030771	A75075CC1690	90,0	81,0	141,0	CC...1605...	2,0

Spare Parts

For insert size	Key	Screw
CC...0602...	T07P-3	C02504-T07P
CC...09T3...	T15P-3	C04008-T15P
CC...1204...	T15P-3	C05012-T15P
CC...1605...	T15P-3	C05012-T15P
CP...0502...	T07P-3	C02245-T07P

Please check availability in current price and stock-list
 For insert fixing spare screws and torx keys, see page(s) 479
 For rough boring recommended inserts, see page(s) 474

Rough boring insert holders 90°, for CC.. and CP.. inserts, for EPB 750 heads



- For fitting onto heads EPB 750
- Symmetrical boring requires two standard type A insert holders
- Staggered boring requires one standard type A and one extended type B insert holders

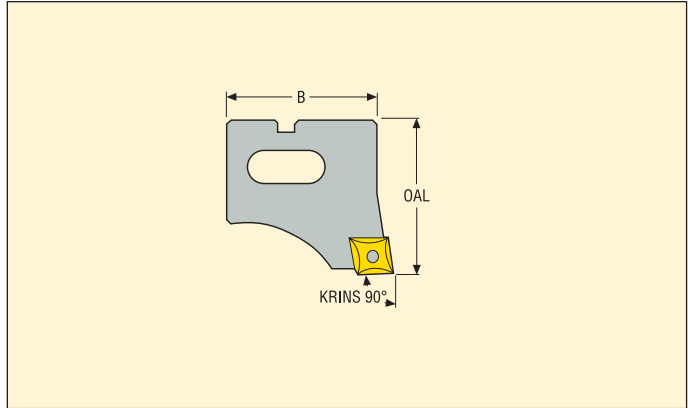

Insert holders type	For head	Capacity DCN-DCX Ø mm	Ordering and Product No.	Designation	KRINS°	Dimensions in mm		Suitable insert size	KG
						OAL	B		
Extended type B	EPB 75000	18,0-24,0	00026705	A75001CP0590	90,0	22,8	16,5	CP...0502...	0,01
	EPB 75010	23,0-31,0	00026706	A75011CC0690	90,0	26,85	21,5	CC...0602...	0,02
	EPB 75020	30,0-40,0	00026707	A75021CC0690	90,0	30,35	27,0	CC...0602...	0,04
	EPB 75030	39,0-51,0	00026708	A75031CC0990	90,0	41,4	35,0	CC...09T3...	0,08
	EPB 75040	50,0-65,0	00026709	A75041CC1290	90,0	45,5	43,0	CC...1204...	0,13
	EPB 75050	64,0-86,0	00026710	A75051CC1290	90,0	52,6	54,0	CC...1204...	0,25
	EPB 75060	85,0-115,0	00026711	A75061CC1290	90,0	68,6	70,0	CC...1204...	0,55
	EPB 75060	85,0-115,0	00030774	A75061CC1690	90,0	68,6	70,0	CC...1605...	0,55
	EPB 75060	85,0-115,0	00092963	A75061SC1280	80,0	69,8	70,0	SC...1204...	0,57
	EPB 75060	114,0-144,0	00026712	A75066CC1290	90,0	68,6	100,0	CC...1204...	0,91
	EPB 75060	114,0-144,0	00030775	A75066CC1690	90,0	68,6	100,0	CC...1605...	0,91
	EPB 75070	114,0-160,0	00026713	A75071CC1290	90,0	81,6	95,0	CC...1204...	1,16
	EPB 75070	114,0-160,0	00030776	A75071CC1690	90,0	81,6	95,0	CC...1605...	1,16
	EPB 75070	159,0-205,0	00026714	A75076CC1290	90,0	81,6	141,0	CC...1204...	2,0
	EPB 75070	159,0-205,0	00030778	A75076CC1690	90,0	81,6	141,0	CC...1605...	2,01

Spare Parts

For insert size	Key	Screw
CC...0602...	T07P-3	C02504-T07P
CC...09T3...	T15P-3	C04008-T15P
CC...1204...	T15P-3	C05012-T15P
CC...1605...	T15P-3	C05012-T15P
CP...0502...	T07P-3	C02245-T07P
SC...1204...	T15P-3	C05012-T15P

Please check availability in current price and stock-list
 For insert fixing spare screws and torx keys, see page(s) 479
 For rough boring recommended inserts, see page(s) 474

Rough boring insert holders 80°, for SC.. inserts, for EPB 750 heads



- For fitting onto heads EPB 750
- Symmetrical boring requires two standard type A insert holders
- Staggered boring requires one standard type A and one extended type B insert holders

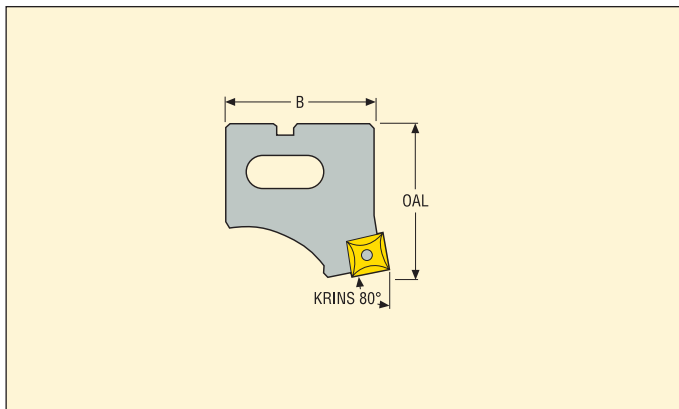

Insert holders type	For head	Capacity DCN-DCX Ø mm	Ordering and Product No.	Designation	KRINS°	Dimensions in mm		Suitable insert size	KG
						OAL	B		
Standard type A	EPB 75000	18,0-24,0	00026715	A75000SC0580	80,0	22,5	16,5	SC...0502...	0,01
	EPB 75010	23,0-31,0	00026716	A75010SC0680	80,0	26,5	21,5	SC...0602...	0,02
	EPB 75020	30,0-40,0	00026717	A75020SC0680	80,0	30,0	27,0	SC...0602...	0,04
	EPB 75030	39,0-51,0	00026718	A75030SC0980	80,0	41,0	35,0	SC...09T3...	0,08
	EPB 75040	50,0-65,0	00026719	A75040SC1280	80,0	45,0	43,0	SC...1204...	0,03
	EPB 75050	64,0-86,0	00051986	A75050SC1280	80,0	52,0	54,0	SC...1204...	0,25
	EPB 75060	85,0-115,0	00052207	A75060SC1280	80,0	68,0	70,0	SC...1204...	0,56
	EPB 75060	85,0-115,0	00039863	A75060SC1580	80,0	68,0	70,0	SC...1505...	0,56
	EPB 75060	114,0-144,0	00051989	A75065SC1280	80,0	68,0	100,0	SC...1204...	0,94
	EPB 75060	114,0-144,0	00039865	A75065SC1580	80,0	68,0	100,0	SC...1505...	1,0
	EPB 75070	114,0-160,0	00026723	A75070SC1280	80,0	81,0	95,0	SC...1204...	1,2
	EPB 75070	114,0-160,0	00039867	A75070SC1580	80,0	81,0	95,0	SC...1505...	1,18
	EPB 75070	159,0-205,0	00026724	A75075SC1280	80,0	81,0	141,0	SC...1204...	2,09
EPB 75070	159,0-205,0	00039869	A75075SC1580	80,0	81,0	141,0	SC...1505...	2,1	

Spare Parts

For insert size	Key	Screw
SC...0502...	T07P-3	C02245-T07P
SC...0602...	T07P-3	C02504-T07P
SC...09T3...	T15P-3	C04008-T15P
SC...1204...	T15P-3	C05012-T15P
SC...1505...	T15P-3	C05012-T15P

Please check availability in current price and stock-list
 For insert fixing spare screws and torx keys, see page(s) 479
 For rough boring recommended inserts, see page(s) 474

Rough boring insert holders 80°, for SC.. inserts, for EPB 750 heads

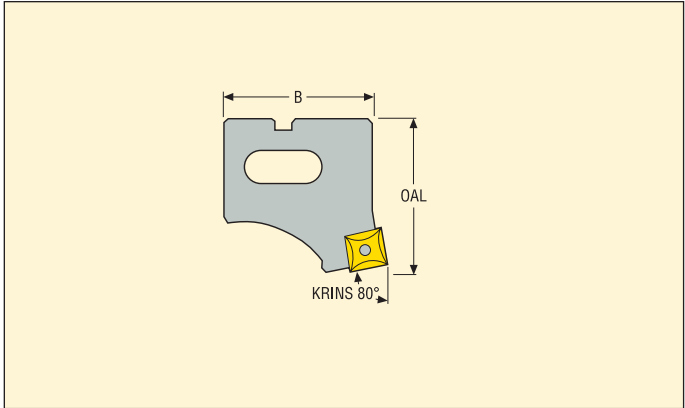
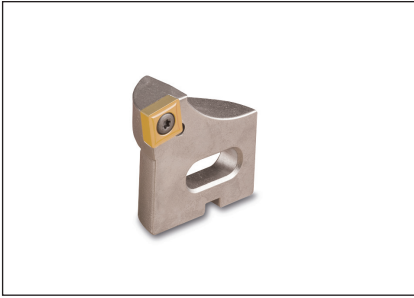

- For fitting onto heads EPB 750
- Symmetrical boring requires two standard type A insert holders
- Staggered boring requires one standard type A and one extended type B insert holders

Insert holders type	For head	Capacity DCN-DCX Ø mm	Ordering and Product No.	Designation	KRINS°	Dimensions in mm		Suitable insert size	KG
						OAL	B		
Extended type B	EPB 75000	18,0-24,0	00092946	A75001SC0580	80,0	23,2	16,5	SC...0502...	0,01
	EPB 75010	23,0-31,0	00092947	A75011SC0680	80,0	27,3	21,5	SC...0602...	0,02
	EPB 75020	30,0-40,0	00092948	A75021SC0680	80,0	30,9	27,0	SC...0602...	0,04
	EPB 75030	39,0-51,0	00092949	A75031SC0980	80,0	42,2	35,0	SC...09T3...	0,08
	EPB 75040	50,0-65,0	00092961	A75041SC1280	80,0	46,4	43,0	SC...1204...	0,14
	EPB 75050	64,0-86,0	00092962	A75051SC1280	80,0	53,7	54,0	SC...1204...	0,26
	EPB 75060	85,0-115,0	00039864	A75061SC1580	80,0	70,3	70,0	SC...1505...	0,57
	EPB 75060	114,0-144,0	00092964	A75066SC1280	80,0	69,8	100,0	SC...1204...	0,96
	EPB 75060	114,0-144,0	00039866	A75066SC1580	80,0	70,3	100,0	SC...1505...	0,96
	EPB 75070	114,0-160,0	00092965	A75071SC1280	80,0	82,8	95,0	SC...1204...	1,21
	EPB 75070	114,0-160,0	00039868	A75071SC1580	80,0	83,3	95,0	SC...1505...	1,21
	EPB 75070	159,0-205,0	00092968	A75076SC1280	80,0	82,8	141,0	SC...1204...	2,16
	EPB 75070	159,0-205,0	00039870	A75076SC1580	80,0	83,3	141,0	SC...1505...	2,14

Spare Parts

For insert size	Key	Screw
SC...0502...	T07P-3	C02245-T07P
SC...0602...	T07P-3	C02504-T07P
SC...09T3...	T15P-3	C04008-T15P
SC...1204...	T15P-3	C05012-T15P
SC...1505...	T15P-3	C05012-T15P

Please check availability in current price and stock-list
 For insert fixing spare screws and torx keys, see page(s) 479
 For rough boring recommended inserts, see page(s) 474

Rough boring insert holders 90°, for CN.. inserts, for EPB 750 heads

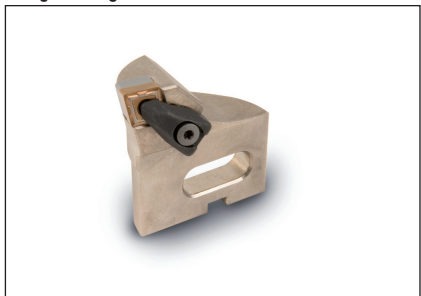

- For fitting onto heads EPB 750
- Symmetrical boring requires two standard type A insert holders (Type B extended insert holders for CN.. inserts not available)

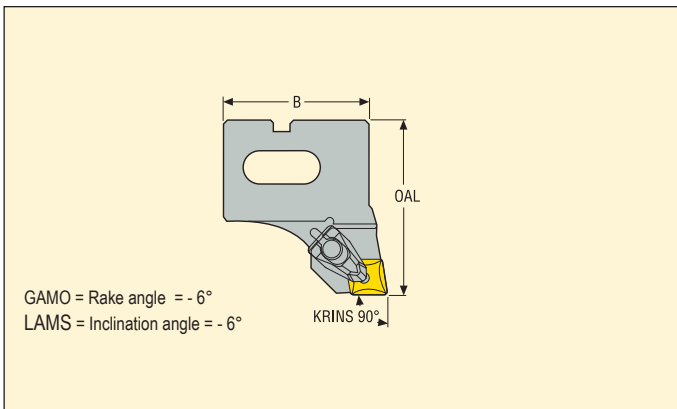

Insert holders type	For head	Capacity DCN-DCX Ø mm	Ordering and Product No.	Designation	KRINS°	Dimensions in mm		Suitable insert size	KG
						OAL	B		
Standard type A	EPB 75050	64,0-86,0	02786307	A75050CN1290	90,0	63,0	55,0	CN...1204...	0,28
	EPB 75060	85,0-115,0	02786308	A75060CN1290	90,0	68,0	69,5	CN...1204...	0,58
	EPB 75060	114,0-144,0	02786309	A75065CN1290	90,0	68,0	99,5	CN...1204...	0,98
	EPB 75070	114,0-160,0	02786310	A75070CN1290	90,0	85,0	95,0	CN...1204...	1,25
	EPB 75070	159,0-205,0	02786311	A75075CN1290	90,0	85,0	140,0	CN...1204...	2,03

Spare Parts

For insert size	Anvil screw	Clamp kit	Insert shim	Key
CN...1204...	CSC6312-T15P	CD12-S12	UCN443	T15P-3

Please check availability in current price and stock-list
For rough boring recommended inserts, see page(s) 475

Instructions

Recommended machining conditions

Spindle power:

As rough boring requires high machine power, we recommend to check that the machine is suitable. Staggered boring is a solution to reduce the power needs, as the feed is divided by two for the same total depth of cut, compared to symmetrical setting.

Optimum performance is obtained with through coolant (higher machining data, better surface finish, better chip evacuation, longer insert life).

For detailed user instructions, please refer to the operating instructions supplied as part of the delivery content of the boring heads and with the Steadyliner® bars.

These operating instructions can also be downloaded from www.secotools.com.

Maximum speeds for rough boring heads

Head	Capacity \varnothing mm	Max. RPM	Implied max cutting speed v_c at min. Cap.	Implied max cutting speed v_c at max. Cap.
Rough boring heads (with two identical insert holders set symmetrically), with Graflex® connection				
A750 00	18-24	15000	848	1131
A750 10	23-31	12000	867	1169
A750 20	30-40	9500	895	1194
A750 30	39-51	7500	919	1202
A750 40	50-65	5700	895	1164
A750 50	64-86	4500	905	1216
A750 60	85-115	3500	935	1264
	114-144	2700	967	1221
A750 70	114-160	2500	895	1257
	159-205	2000	999	1288
Rough boring heads (with two identical insert holders set symmetrically), with Seco-Capto™ connection				
C3-391.0750-30	39-51	7500	919	1202
C4-391.0750-40	50-65	5700	895	1164
C5-391.0750-50	64-86	4500	905	1216
C6-391.0750-60	85-115	3500	935	1264
	114-144	2700	967	1221
C8-391.0750-70	114-160	2500	895	1257
	159-205	2000	999	1288

Note: The maximum speeds are related to the boring head's mechanical design and balancing quality. Speeds inside these limits have to be chosen in regard to the other machining conditions, e.g. workpiece material, cutting edge (insert), tooling length, machine spindle. At speeds from approx. 8000 RPM and above, the basic holders and the extensions/reducers should be fine balanced.

Instructions Troubleshooting

Position	Possible cause	Solution
Poor chip control	Feed rate too low	Increase feed rate
	Excessive DOC	Use staggered method
Chatter & Vibrations	Excessive speed	Reduce cutting speed, not feed
	Extreme L/D ratio	Shorten tool to increase stiffness
		Increase holding arbor's and intermediate's OD
		Use Steadyline bar
		Use carbide or heavy metal extensions
	Too large insert radius	Use insert with smaller radius
	Unstable workpiece	Improve fixture and clamping support
Lead angle κ is 80°	Change to $\kappa=90^\circ$, type CC insert	
Insert chipping or breaking	Wrong insert	Change to tougher grade of insert
		Use larger radius if available
	Severe interrupted cut	Decrease speed, decrease feed
	Chips packing and re-cutting	Check for boring bar/bore diameter clearance
Improve chip control, increase feed		
Poor tool life	Wrong insert	Change to higher wear resistant grade
	Excessive cutting speed	Reduce speed
	Insert chipping	Check DOC and feed rate
	Too low coolant pressure	Increase coolant pressure
Chips not evacuating	Boring assembly too large	Reduce to a smaller head with extended insert holders when possible
	Excessive DOC	Use staggered method; prefer CC.. instead of CN.. inserts (particularly when using the boring head at its small diameters).
	Inadequate space below bore	Set the workpiece higher onto the table
	Poor chip control	See above
Insufficient machine power	Excessive feed rate	Reduce feed (not less than 25% of insert radius)
	Excessive DOC	Use staggered method
	Low machine power	RPM in area of low spindle torque: increase speed
		RPM in area of gear change: adjust RPM
		Change insert to higher rake angle (to HSS in extreme cases)
Reduce DOC		
Excessive hole exit burr	Excessive feed rate	Reduce feed
	CC type insert holders 90°	Use 80° square insert holder
	Cutting forces too high	Reduce DOC
		Reduce insert radius

EPB 610 Rough boring heads – Overview

Graflex® connection

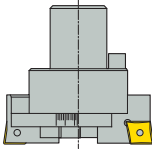

Ø39-51mm

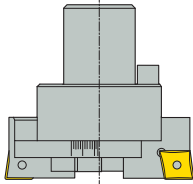

Ø50-65mm

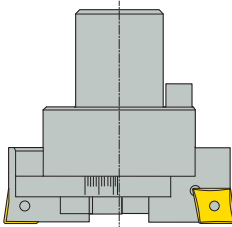

Ø64-86mm

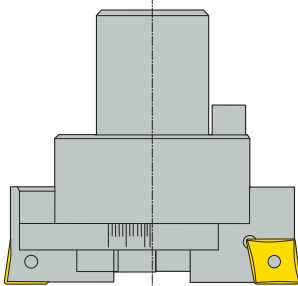

Ø85-115mm

GL connection

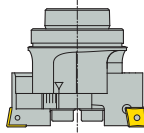

Ø36-46mm

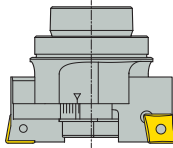

Ø45-56mm

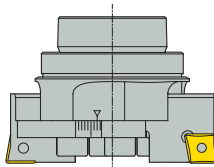

Ø55-69mm

BA connection

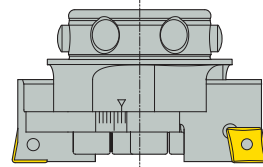

Ø66-88mm

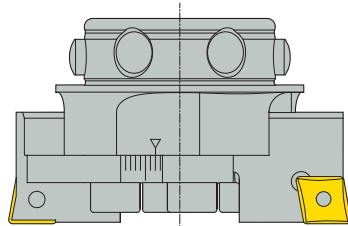

Ø86-116mm

EPB 610 Rough boring heads – Guide

Features

A rough boring head assembly is a combination of 1 body (head) and 2 insert holders

- Achieving geometrical hole precision starting from cast, flame cut or drilled hole
- Minimised unbalance thanks to a symmetrical design

Compact

- Short body to maximise the rigidity of the boring assembly and to deliver the best damping performances when used on Steadyline® turning and boring bars
- Reduced weight for fast tool changing and spindle acceleration

Intuitive and fast setting

- Each insert holder features its push and pull setting mechanism allowing easy and fast setting of the diameter, using a pre-setter
- Diameter scales roughly visualise the insert holders positions

Insert holders

- A610...CC... insert holders achieve a 90° lead angle for rhombic inserts, 0° rake angle and 0° inclination angle
- The insert holders are suitable for both EPB 610 Graflex® and EPB 610 GL heads

Productivity

- High rigidity resulting from a tight fitting of the insert holders into the head's body, and large clamping screws
- Possibility to take a depth of cut a_p up to half of the insert's width, maximising the chip removal rate and allowing a total exploitation of the inserts
- Staggered boring using a shim (part of heads delivery contents) to offset one insert holder in order to increase or to split the radial depth of cut
- Through coolant delivery directed towards the cutting edges

Product range

- EPB 610 rough boring heads are available with Graflex®, GL and BA machine side connections

EPB 610 Graflex®

- Graflex®: 4 compact rough boring heads for \varnothing 39 to 115 mm
- The flexible Graflex® modular System allows to build up optimal boring assemblies from Graflex® adapters, intermediate modules and boring heads

EPB 610 GL and BA, for Steadyline® vibration damping bars

- GL: 3 short and compact rough boring heads, for \varnothing 36 to 69 mm
- BA: 2 short and compact rough boring heads, for \varnothing 66 to 116 mm
- Particularly adapted to the Steadyline® turning and boring bars. Boring performances, when used on long Steadyline® GL bars, are similar to non-damped shorter assemblies (<6xD).



Graflex



GL



BA

EPB 610 Rough boring heads – Guide

SETTING

Symmetrical boring:

Symmetrical boring means both cutting edges are set on the same diameter and same height.

Staggered boring:

Staggered boring means one cutting edge is offset as a leading cutting edge (entering the bore first), operating on a smaller diameter than the second edge set on the diameter to be realised: It requires a shim (part of the head delivery content) to be fitted between the boring head's body and one insert holder to achieve the (+) axial offset, see table below.

Shims thicknesses

Shim Part No.	Thickness (mm)
AU6103003	0,4
AU6104003	0,5
AU6105003	0,6
AU6106003	0,6

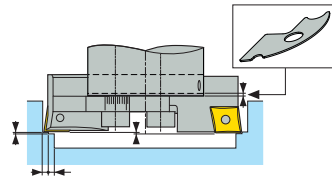
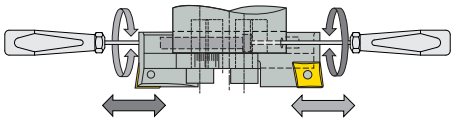

EPB 610 Graflex® – Rough boring heads

Graflex®

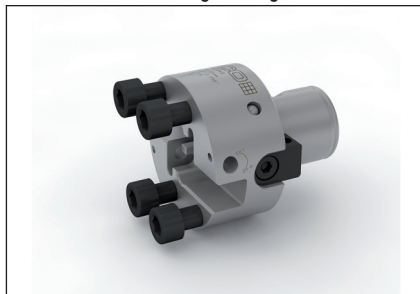

- Symmetrical and staggered boring modes are possible
- Individual insert holder adjusting mechanism
- Internal coolant supply towards cutting edge

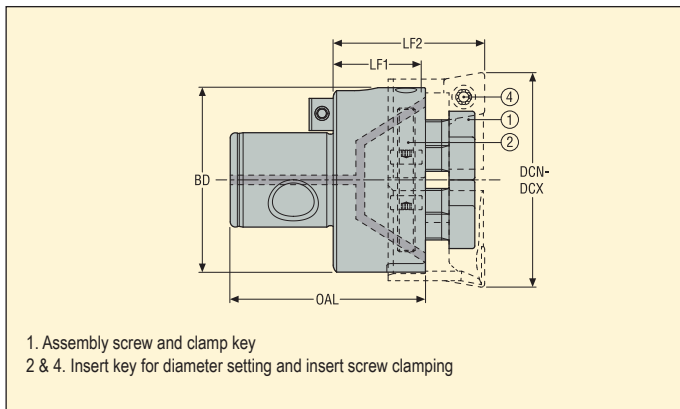

Machine side Graflex size	Workpiece side Capacity DCN-DCX Ø mm	Ordering and Product No.	Designation	Dimensions in mm				Max. RPM**	
				OAL	LF1	LF2	BD		
G3	39,0-51,0	02904453	A61030	43,5	23,5	36,4	34,0	7500	0,18
G4	50,0-65,0	02904454	A61040	45,5	21,5	35,3	43,0	5700	0,27
G5	64,0-86,0	02904455	A61050	55,0	25,0	42,3	54,0	4500	0,54
G6	85,0-115,0	02904457	A61060	69,0	29,0	47,8	63,0	3500	0,93

Insert holders have to be ordered separately, see page(s) 408.

*Without insert holder.

** Additional information about max RPM, see Instruction pages.

Spare Parts

For head	Assembly screw	Clamp key	Insert key	Shim, staggered boring	Tenon
A610 30	950DC0616	03HL05	T15P-3	AU6103003	90M3
A610 40	950D0616	03HL05	T15P-3	AU6104003	90M4
A610 50	950D0820	03HL06	T15P-3	AU6105003	90M5
A610 60	950D0822	03HL06	T15P-3	AU6106003	90M6

Please check availability in current price and stock-list

EPB 610 GL – Rough boring heads, compact

GL

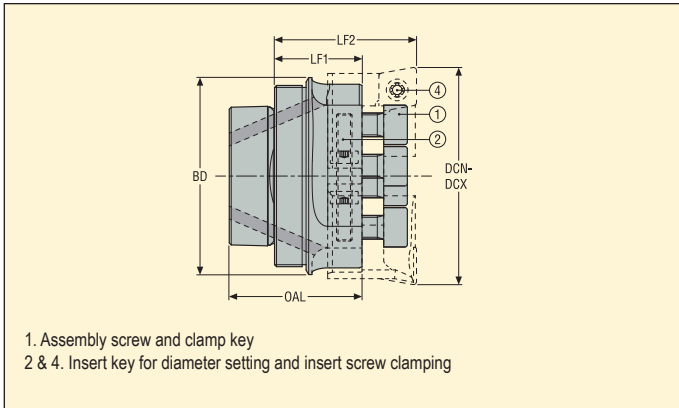

- Designed for GL32, GL40 and GL50 Steadyliner® turning and boring bars
- Symmetrical and staggered boring modes are possible
- Individual insert holder adjusting mechanism
- Internal coolant supply towards cutting edge

1. Assembly screw and clamp key
- 2 & 4. Insert key for diameter setting and insert screw clamping

GL size	Workpiece side Capacity DCN-DCX Ø mm	Ordering and Product No.	Designation	Dimensions in mm				Max. RPM**	KG*
				OAL	LF1	LF2	BD		
GL32	36,0-46,0	02904458	GL32-0610-20	27,6	21,1	32,0	32,0	7500	0,10
GL40	45,0-56,0	02904459	GL40-0610-30	31,6	22,1	35,0	40,0	5700	0,20
GL50	55,0-69,0	02904460	GL50-0610-40	33,7	22,2	36,0	50,0	4500	0,30

Insert holders have to be ordered separately, see page(s) 408.
 **Additional information about max RPM, see Instruction pages.

*Without insert holder.

Spare Parts

For head	Assembly screw	Clamp key	Insert key	Shim, staggered boring
GL32-0610-20	950DC0412	03HL03	T07P-3	AU6102003
GL40-0610-30	950DC0616	03HL05	T15P-3	AU6103003
GL50-0610-40	950D0616	03HL05	T15P-3	AU6104003

Please check availability in current price and stock-list

EPB 610 BA – Rough boring heads

BA



- Designed for BA60 and BA80 Steadyline® turning and boring bars
- Symmetrical and staggered boring modes are possible
- Individual insert holder adjusting mechanism
- Internal coolant supply towards cutting edge

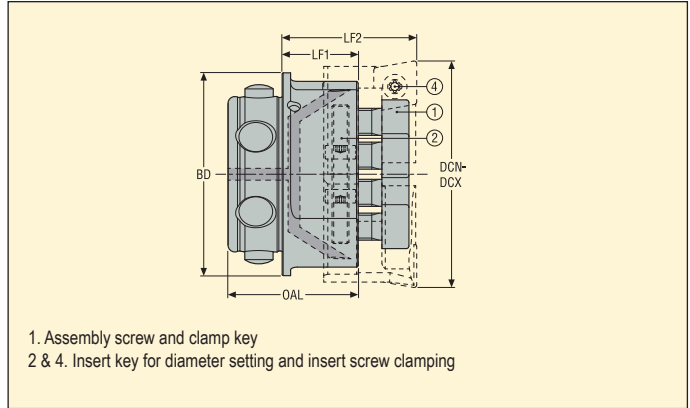

Machine side BA size	Workpiece side Capacity DCN-DCX ∅ mm	Ordering and Product No.	Designation	Dimensions in mm				Max. RPM**	
				OAL	LF1	LF2	BD		
BA060	66,0-88,0	03204092	BA060-RB610-50	38,5	22,5	39,8	60,0	4000	0,80
BA080	86,0-116,0	03204093	BA080-RB610-60	44,5	22,5	39,8	80,0	3000	1,10

Insert holders have to be ordered separately, see page(s) 408. *Without insert holder
 ** Additional information about max RPM, see Instruction pages.

Spare Parts

For head	Clamp key	Clamp screw	Insert key	Shim, staggered boring
BA060-RB610-50	03HL06	950D0820	T15P-3	AU6105003
BA080-RB610-60	03HL06	950D0822	T15P-3	AU6106003

Please check availability in current price and stock-list

Rough boring heads, EPB 610

Insert holders, for rough boring heads EPB 610

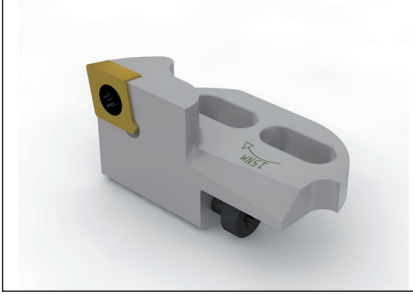

- Suitable for boring heads EPB 610 with Graflex®, GL or BA connection

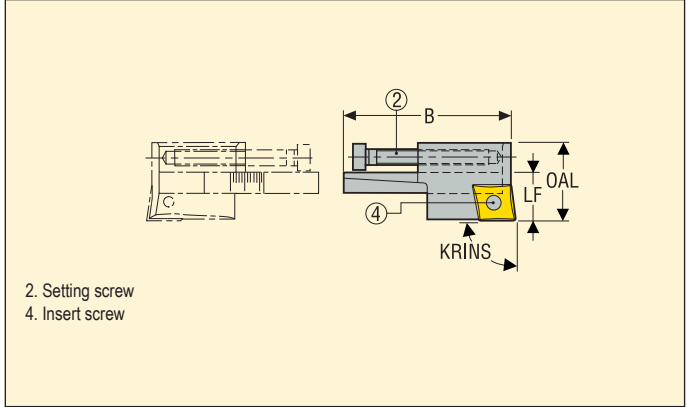

For boring head	Capacity DCN-DCX Ø mm	Ordering and Product No.	Designation	KRINS°	Dimensions in mm			Suitable insert size	KG
					OAL	LF	B		
EPB 61020	36,0-46,0	02971268	A61020CC0690	90,0	17,6	10,9	26,0	CC...0602...	0,1
EPB 61030	39,0-56,0	02904461	A61030CC0990	90,0	21,6	12,9	33,0	CC...09T3...	0,1
EPB 61040	50,0-69,0	02904462	A61040CC0990	90,0	22,5	13,8	43,8	CC...09T3...	0,1
EPB 61050	64,0-86,0	02904463	A61050CC1290	90,0	27,5	17,3	57,4	CC...1204...	0,2
EPB 61060	85,0-115,0	02904464	A61060CC1290	90,0	30,5	18,8	75,0	CC...1204...	0,3

Spare Parts

For insert holder	Insert screw	Setting screw
A61020CC0690	C02504-T07P	19A61020
A61030CC0990	C04008-T15P	19A61030
A61040CC0990	C04008-T15P	19A61040
A61050CC1290	C05012-T15P	19A61050
A61060CC1290	C05012-T15P	19A61060

Please check availability in current price and stock-list
 For rough boring recommended inserts, see page(s) 474-475
 Note: A key for insert screw clamping is part of EPB 610 heads delivery contents.

EPB 610 Rough boring heads – Instructions

Recommended tightening torques. Maximum feed per rev. when staggered

EPB 610 boring heads size	30	40	50	60
Tightening torque of clamp screws for insert holders clamping (N.m)	2 x 25	4 x 25	4 x 40	4 x 40
f Max. feed rate when staggered boring (mm/rev)	0,4	0,5	0,6	0,6

Recommended machining conditions

Spindle power:

As rough boring requires high machine power, we recommend to check that the machine is suitable. Staggered boring is a solution to reduce the power needs, as the feed is divided by two for the same total depth of cut, compared to symmetrical setting. Optimum performance is obtained with through coolant (higher machining data, better surface finish, better chip evacuation, longer insert life).

For detailed user instructions, please refer to the operating instructions supplied as part of the delivery content of the boring heads and with the Steadyline® bars. These operating instructions can also be downloaded from www.secotools.com.

Maximum speeds for EPB 610 rough boring heads

Note: The maximum speeds shown in boring heads Product pages are related to the boring head's mechanical design and balancing quality. Speeds inside these limits have to be chosen in regard to the other machining conditions, e.g. workpiece material, cutting edge (insert), tooling length, machine spindle.

By boring applications with Steadyline® bars, make sure not to overpass the max. RPM of the bars : See the Operating instructions supplied with the Steadyline® turning and boring bars.



Overview



OD-overturning



Grooving

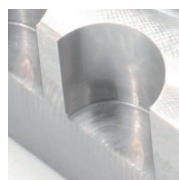

Interrupted cut boring

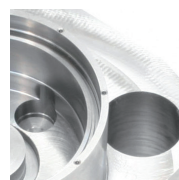

Boring

Overview

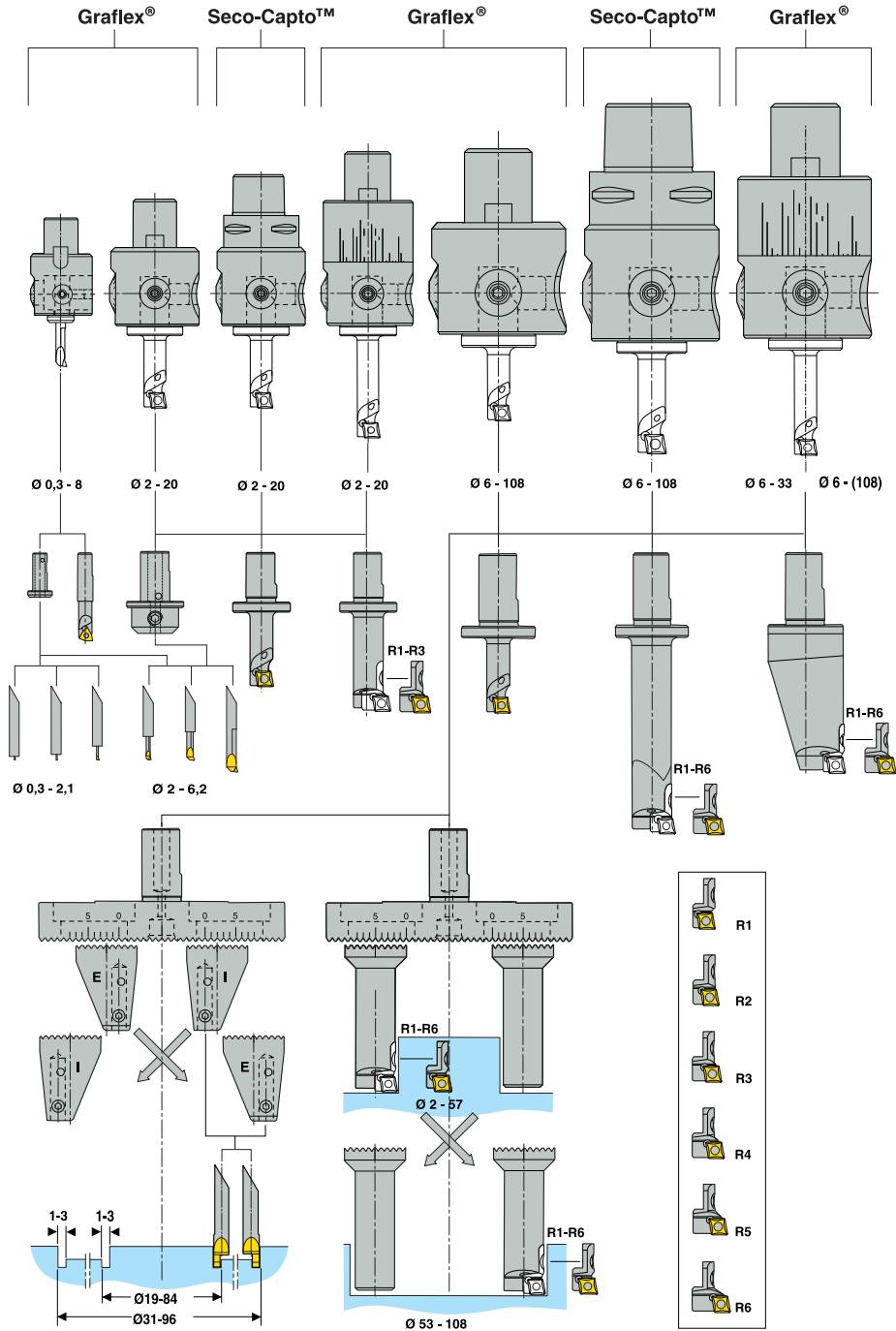

Axiabore™ type fine boring heads for bores \varnothing 0,3 to 108 mm

An Axiabore™ type head is an assembly of a body (head) and a tool.

Axiabore™ type head selection

	Capacity	HSM/ Max speeds	Hole geometry	Cost effective	Multipurpose
Nanobore™ A760 01	\varnothing 0,3-8	30000 RPM	■ ■	■ ■	
Axiabore™ A760 02	\varnothing 2-20	12000 RPM	■	■ ■	
Axiabore™ C3-931.0760-02	\varnothing 2-20	12000 RPM	■	■ ■	
Axialibrabore™ A760 12	\varnothing 2-20	24000 RPM or 1500 m/min	■ ■	■	
Axiabore™ Plus - A760 03	\varnothing 6-108	8000* RPM or 1000 m/min	■	■ ■ ■ ■	■ ■ ■ ■
Axiabore™ Plus C5-391.0760-03	\varnothing 6-108	8000* RPM	■	■ ■ ■ ■	■ ■ ■ ■
Axialibrabore™ Plus - A760 13	\varnothing 6-33	20000 RPM or 1500 m/min	■ ■	■	

Axiabore™ type heads exists with Graflex® or Seco-Capto™ connection:

5 Axiabore™ fine boring heads EPB 760 with Graflex® connection for bores \varnothing 0,3 to 108 mm:

- Nanobore™ A760 01
- Axiabore™ A760 02
- Axialibrabore™ A760 12
- Axiabore™ Plus - A760 03
- Axialibrabore™ Plus - A760 13

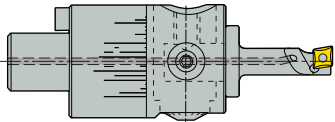

2 Axiabore™ fine boring heads EPB 760 with Seco-Capto™ connection for bores \varnothing 2 to 108 mm:

- Axiabore™ C3-391.0760-02
- Axiabore™ Plus- C5-391.0760-03

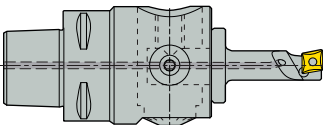

Note: The minimum bore size of the smallest Seco-Capto™ fine boring head is \varnothing 2 mm with the smallest available Seco-Capto™ C3 connection. For \varnothing 0,3 to 8 mm use Nanobore™ head with connection size G2 in conjunction with the appropriate Seco-Capto™/Graflex® adapter.

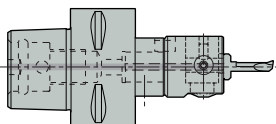

Seco-Capto™ adapter and Graflex® head: \varnothing 0,3 to 8 mm

Note: Features, Instructions (tool fitting procedure, diameter setting, MPA assembly procedure, maximum speeds, recommended cutting speeds, troubleshooting), **suitable tools and insert holders** are similar for both types of EPB 760 fine boring heads of similar boring capacity size, regardless of connection type.

Boring tools

Note: In the Product pages, it is clearly mentioned which tools are suitable for which heads.

Boring tools, solid carbide (shank \varnothing 4 mm) for the smallest diameters (\varnothing 0,3 to 6,2 mm), lead angle 98°. Require reduction bushes to fit into Nanobore™ and Axia(libra)bore™ heads. The tools have an angled machine side for cutting edge orientation according to ISO.

Boring bars, insert type (shanks \varnothing 6, 12 or 16 mm) for \varnothing 6 to 13 mm, 'steel' type for short tools, 'carbide' type for long tools. For WB..0301.. or CC..0602.. inserts and 90° lead angle.

Direct fitting into the heads. The locking flat achieves a cutting edge orientation according to ISO.

Boring bars, modular composed of a 'shank' and an 'insert holder' for \varnothing 13 to 63 mm.

Shanks (\varnothing 12 or 16 mm) in 'steel' for short, 'carbide' for long and 'Lightweight / aluminium' for the largest diameters. Direct fitting into the heads.

Six insert holders for CC..0602.. inserts and 90° lead angle, compatible with all shanks to build up a wide boring capacity on a common shank.

Multi-purpose adapter (MPA)

MPA for boring and OD-overturning, as well as face grooving on the - Axiabore™ Plus - head.

The MPA and tools have a serrated interface, for precise orientation and positioning increments (2,5 mm on diameter).

Directional through coolant nozzle included.

Select the components to build up an MPA type tool on the MPA tool selection charts. See assembly details in the Instructions chapter.

Set up a Boring or OD-overturning assembly.

Boring and OD-overturning assemblies use the same shank equipped with an insert holder, and a counterweight.

Boring assembly: Select the appropriate insert holder to be assembled onto the boring/OD-overturning shank, using the selection chart 'Boring with MPA' (part of following Product pages).

OD-overturning assembly: Select the appropriate insert holder to be assembled onto the boring/OD-overturning shank, using the selection chart 'OD-overturning with MPA' (part of following Product pages). See assembly details in the Instructions chapter.

Building a grooving assembly





A grooving assembly requires:

- a pair of grooving tool holders (one E='External' and one I='Internal'),
- one grooving tool 'against Spigot' or 'against Bore'.

When the groove is not against a spigot wall nor against a bore wall, both tool types are suitable.

See the selection charts 'Grooving tool for grooving with MPA'.

Features

<p>Nanobore™ head Part No. A76001</p> 	<p>Ultra small head for fine boring \varnothing 0,3 – 8 mm: External diameter 25 mm, length 25 mm, with Graflex® connection size G2, tool fitting \varnothing 6 mm. Operating speeds up to 30 000 RPM allows performance machining of very small diameters.</p> <p>The reduction bush (6-4 mm) with orientation flat and pin for fitting the solid boring tools is part of the head delivery content.</p>
<p>Axiabore™ head Part No. A76002 and C3-391.0760-02</p>  	<p>Small heads for fine boring \varnothing 2 – 20 mm: External diameter 36,5 mm, length 32 mm, with Graflex® connection size G3 and Seco-Capto™ connection size C3, tool fitting \varnothing 12 mm. These heads sizes are optimised for difficult-to-access bores.</p> <p>The reduction bush (12-4 mm) with orientation flat and pin for fitting the solid boring tools is part of the head delivery content. Note: Smaller tools from Nanobore™ (0,3 to 2,1 mm) can also be fitted, but the machining speed will be limited to 12000 RPM: Nanobore® head should be preferred.</p>
<p>Axialibrabore™ head Part No. A76012</p> 	<p>Small balanceable head for fine boring \varnothing 2 – 20 mm: Same features as the Axiabore™ head, but with fine balancing (body length 50 mm). With Graflex® connection size G3.</p> <p>Fine balanceable heads allow higher speeds up to 24 000 RPM or 1500 m/min (whichever is reached first without exceeding either of them), improve the hole geometry and reduce the machine spindle stress. 'LibraOne' balancing is performed by setting the graduated balancing ring (in accordance with the balancing code of the tool used, and the diameter to be bored) in line with the mark on the boring head. No chart needed.</p>

Features

Axiabore™ Plus - head
Part No. A76003 and C5-391.0760-03



Multi-purpose heads for fine boring \varnothing 6 to 108 mm, OD-overturning \varnothing 2 to 57 mm and grooving \varnothing 19 to 96 mm:

External diameter 54 mm, length 45 mm, with Graflex® connection size 5 and Seco-Capto™ connection size 5, tool fitting \varnothing 16 mm.

Suitable tools: all tools with shank \varnothing 16 mm, for direct fitting into the heads.

This head has also been designed to be equipped with the MPA (multi-purpose adapter), to perform large diameter fine boring, OD-overturning and face grooving.

Axialibrabore™ Plus - head
Part No. A76013



Balanceable head for fine boring \varnothing 6 to 33 mm:

Same features as the - Axiabore™ Plus - head, but with fine balancing (body length 65 mm). With Graflex® connection size G5.

Fine balanceable heads allow higher speeds up to 20 000 RPM or 1500 m/min (whichever is reached first without exceeding either of them), improve the hole geometry and reduce the machine spindle stress. 'LibraOne' balancing is performed by setting the graduated balancing ring in line with the mark on the boring head (balancing code of the tool used, and the diameter to be bored). No chart needed.

Fine balancing is only possible for the smallest boring tools (\varnothing 6 to 33 mm).

Note: if using a larger 'Alu', or a 'MPA' tool from the - Axiabore™ Plus - onto the - Axialibrabore™ Plus - head, fine balancing is not possible and the balancing ring should be set in the head's pre-balancing position (depending on the operation to be performed, see Instructions chapter). The maximum speed becomes the same as for the - Axiabore™ Plus.

EPB 760 – Axiabore™ type heads, balanceable

Graflex®



- LibraOne built-in balancing system based on a single balancing setting ring
- With micrometric adjusting (increment 0,01 mm and vernier 2,5 µm, on the diameter)

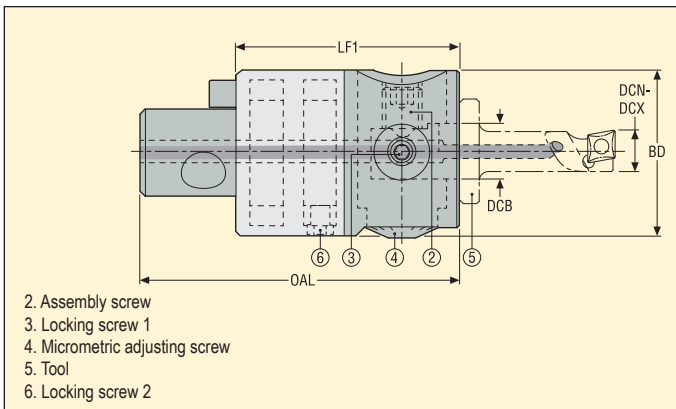

Machine side Graflex size	Workpiece side Capacity DCN-DCX ∅ mm	***	Ordering and Product No.	Designation	Dimensions in mm				Max operating speed**		KG*
					OAL	LF1	DCB	BD	Max. RPM**	Max. m/min**	
G3	2,0-20,0		02594938	A76012	70,0	50,0	12,0	36,5	24000	1500	0,39
G5	6,0-33,0	***	02594943	A76013	95,0	65,0	16,0	54,0	20000	1500	1,16

For tools, see page(s) 420-422. * Without tool. ** Maximum speed, whichever is reached first without exceeding either of them. *** Capacities – Axiabore™ Plus - head, with balancing.

Spare Parts

Accessories

For head	Assembly screw	Key	Locking screw 1	Locking screw 2	Reduction bush	Tenon	Storage case
A760 12	AU7601212	03M03C	19A71030	AU7601218	05A7601204	90M3A	42M06
A760 13	AU7601312	H04-4	19A71008125	AU7601318	-	90M5A1	42M07

Please check availability in current price and stock-list
Accessories not included in delivery.

EPB 760 – Axiabore™ type heads

Seco-Capto™



- With micrometric adjusting (increment 0,01 mm and vernier 2,5 µm, on the diameter)
- Axiabore™ Plus – allows boring, as well as OD-overturning and face grooving

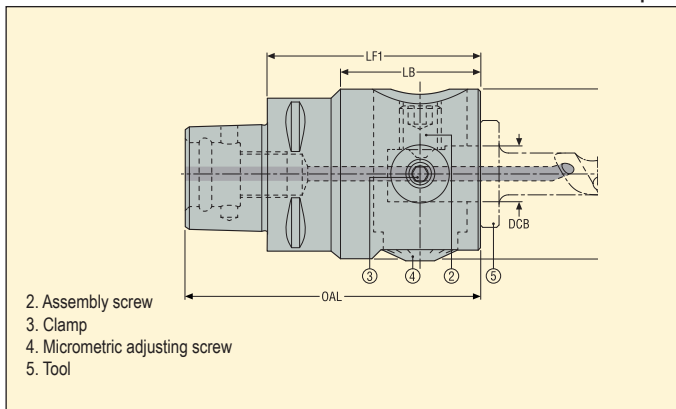

Machine side Capto size	Workpiece side Capacity DCN-DCX ∅ mm	**	Ordering and Product No.	Designation	Dimensions in mm					Max operating speed		***	
					OAL	LF1	LB	DCB	BD	Max. RPM**	Max. m/min**		
C3	2,0-20,0		02822776	C3-391.0760-02	65,0	46,0	30,0	12,0	36,5	12000	1500,0		0,33
C5	6,0-108,0	**	02822777	C5-391.0760-03	95,0	65,0	44,0	16,0	54,0	8000	1500,0	***	1,12

For tools, see page(s) 420-422.*Without tool.**Capacities - Axiabore™ Plus - head for boring 6 to 108 mm, OD-overturning 2 to 57 mm, face grooving 19 to 96 mm.
 ***Max 5000 RPM when using MPA.

Spare Parts

For head	Assembly screw	Key	Locking screw	Reduction bush
C3-391.0760-02	AU7601212	03M03C	19A71030	05A7601204
C5-391.0760-03	AU7601312	H04-4	19A71008125	-

Please check availability in current price and stock-list

Boring bars, insert type, for EPB 760 heads



- Cutting edge orientation ISO
- Through coolant
- Only two insert sizes for all tools

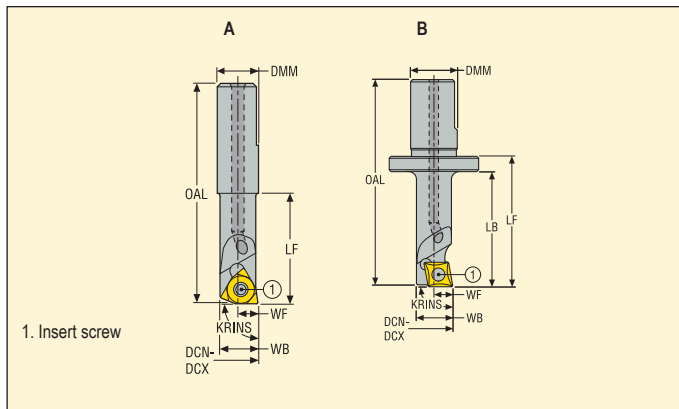

Tool material	For head	Capacity DCM-DCX Ø mm**	Ordering and Product No.	Designation	KRINS°	Dimensions in mm						Suitable insert size	Design	KG	Balancing code
						OAL	LB	LF	DMM	WB	WF				
Steel, indexable insert type	EPB 76001	6,0-8,0	02462590	A762001	90,0	31,7	0,0	16,0	6,0	5,5	2,9	WB..0301..	A	0,01	-
	EPB 76002/12	6,0-8,0	02594947	A762002	90,0	39,7	16,0	20,0	12,0	5,5	2,9	WB..0301..	B	0,03	S21
	EPB 76003/13	6,0-8,0	02594967	A762003	90,0	50,2	16,0	21,0	16,0	5,5	2,9	WB..0301..	B	0,07	S31
	EPB 76002/12	8,0-10,0	02594948	A763002	90,0	45,7	22,0	26,0	12,0	7,4	3,9	WB..0301..	B	0,04	S22
	EPB 76003/13	8,0-10,0	02594968	A763003	90,0	56,2	22,0	27,0	16,0	7,4	3,9	WB..0301..	B	0,08	S32
	EPB 76002/12	10,0-13,0	02594957	A765002	90,0	53,5	30,0	34,0	12,0	9,35	4,8	CC..0602..	B	0,04	S23
	EPB 76003/13	10,0-13,0	02594969	A765003	90,0	64,0	30,0	35,0	16,0	9,35	4,8	CC..0602..	B	0,08	S33
Carbide, indexable insert type	EPB 76001	6,0-8,0	02462591	A762201	90,0	41,7	0,0	26,0	6,0	5,5	2,9	WB..0301..	A	0,02	-
	EPB 76002/12	6,0-8,0	02594958	A762202	90,0	50,7	27,0	31,0	12,0	5,5	2,9	WB..0301..	B	0,06	E21
	EPB 76003/13	6,0-8,0	02594970	A762203	90,0	61,2	27,0	32,0	16,0	5,5	2,9	WB..0301..	B	0,13	E31
	EPB 76002/12	8,0-10,0	02594961	A763202	90,0	60,7	37,0	41,0	12,0	7,4	3,9	WB..0301..	B	0,07	E22
	EPB 76003/13	8,0-10,0	02594971	A763203	90,0	71,2	37,0	42,0	16,0	7,4	3,9	WB..0301..	B	0,14	E32
	EPB 76002/12	10,0-13,0	02594962	A765202	90,0	78,5	55,0	59,0	12,0	9,35	4,8	CC..0602..	B	0,09	E23
	EPB 76003/13	10,0-13,0	02594972	A765203	90,0	89,0	55,0	60,0	16,0	9,35	4,8	CC..0602..	B	0,17	E33

**+0,2 mm complementary capacity achievable.

Spare Parts

For insert size	Insert screw
	
CC..0602..	C02504-T07P
WB..0301..	C02035-T06P

Accessories

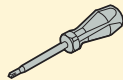
Insert key

T07P-3
T06P-3

Please check availability in current price and stock-list
Accessories not included in delivery.

Boring shanks, for modular fine boring bars, for EPB 760 heads

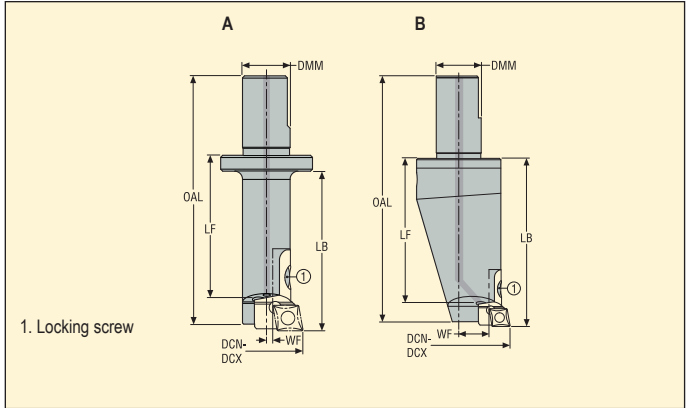

- Several capacities achievable by interchangeable insert holders
- Shank types 'steel' for short bars, 'carbide' for long bars, 'aluminium' for large bars
- Through coolant



Modular boring shank type	For head	***	Capacity DCN-DCX ∅ mm**	Ordering and Product No.	Designation	Dimensions in mm					Design	KG
						OAL	LF	LB	DMM	WF		
Steel	A76002/12		13,0-20,0	02594963	A760S20	62,5	34,0	40,0	12,0	1,4	A	0,06
	A76003/13		13,0-18,0	02594973	A760S30	73,0	35,0	40,0	16,0	1,4	A	0,1
	A76003/13		18,0-33,0	02594974	A760S31	83,0	45,0	50,0	16,0	3,9	A	0,13
Carbide	A76002/12		13,0-20,0	02594964	A760E20	82,5	54,0	60,0	12,0	1,4	A	0,2
	A76003/13		13,0-18,0	02594965	A760E30	103,0	65,0	70,0	16,0	1,4	A	0,21
	A76003/13		18,0-33,0	02594966	A760E31	113,0	75,0	80,0	16,0	3,9	A	0,3
Aluminium	A76003	***	33,0-48,0	02594977	A760A32	88,0	50,0	60,0	16,0	11,5	B	0,14
	A76003	***	48,0-63,0	02594978	A760A33	108,0	70,0	80,0	16,0	19,0	B	0,34

*Without insert holder. **+0,2 mm complementary capacity achievable. ***When used on A760 13, no fine balancing possible.
Select the required shank and insert holder(s) combination(s) using the selection chart on page(s) 424

Spare Parts

For head	Locking screw
EPB 76002/12	C04008-T15P
EPB 76003/13	C04008-T15P
EPB 76003	C04008-T15P

Accessories

Locking key
T15P-3
T15P-3
T15P-3

Please check availability in current price and stock-list
Accessories not included in delivery.

Insert holders, for modular fine boring bars, for EPB 760 heads

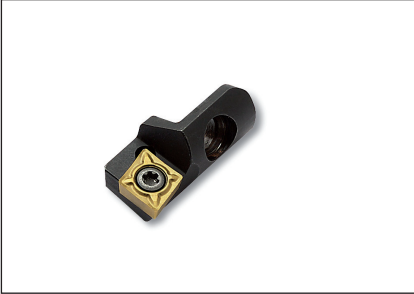

- Single fitting size suitable for all boring (and OD-overturning) shanks
- One insert size for all insert holders

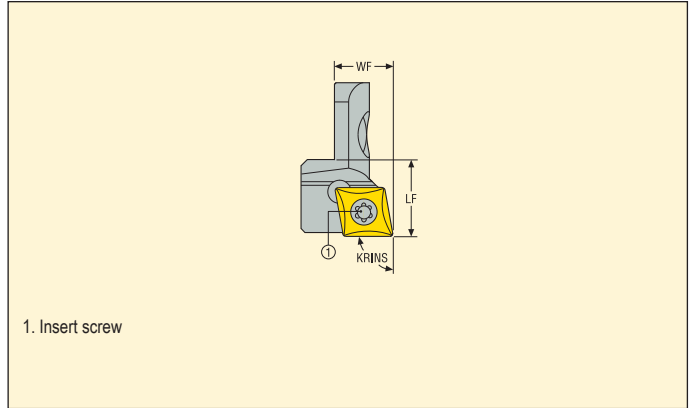

	Ordering and Product No.	Designation	Dimensions in mm		Suitable insert size	KRINS°	
			LF	WF*			
Insert holder	02594979	A765R1	10,0	4,95	CC..0602..	90,0	0,01
	02594983	A765R2	10,0	6,2	CC..0602..	90,0	0,01
	02594984	A765R3	10,0	7,45	CC..0602..	90,0	0,01
	02594987	A765R4	10,0	8,7	CC..0602..	90,0	0,01
	02594989	A765R5	10,0	9,97	CC..0602..	90,0	0,01
	02594990	A765R6	10,0	11,2	CC..0602..	90,0	0,01

*WF when fitted with insert type CC..060204.
 Select the required shank and insert holder(s) combination(s) using the selection chart on page(s) 424

Spare Parts

For insert size	Insert screw
CC...0602...	C02504-T07P

Accessories

Insert key
T07P-3

Please check availability in current price and stock-list
 Accessories not included in delivery.

Selection chart: Boring tools and insert holders suitable for EPB 760 heads

For head	Boring capacity DCN-DCX Ø mm	Boring length LB mm	Designation		DMM (mm)	Suitable insert size	Tool type
			Boring tool	Insert holder			
A760 01	0,3-0,6	1,2	A761 402	–	4	–	Solid carbide
	0,5-1,1	2	A761 412	–	4	–	Solid carbide
	1-2,1	5	A761 422	–	4	–	Solid carbide
	2-3,2	8	A761 432	–	4	–	Solid carbide
	3-4,7	10	A761 442	–	4	–	Solid carbide
	4,5-6,2	15	A761 452	–	4	–	Solid carbide
	6-8	16	A762 001	–	6	WB..0301..	Steel, inserts type
	6-8	26	A762 201	–	6	WB..0301..	Carbide, inserts type
A760 02/ A760 12	2-3,2	8	A761 432	–	4	–	Solid carbide
	3-4,7	10	A761 442	–	4	–	Solid carbide
	4,5-6,2	15	A761 452	–	4	–	Solid carbide
	6-8	16	A762 002	–	12	WB..0301..	Steel, inserts type
	6-8	27	A762 202	–	12	WB..0301..	Carbide, inserts type
	8-10	22	A763 002	–	12	WB..0301..	Steel, inserts type
	8-10	37	A763 202	–	12	WB..0301..	Carbide, inserts type
	10-13	30	A765 002	–	12	CC..0602..	Steel, inserts type
	10-13	55	A765 202	–	12	CC..0602..	Carbide, inserts type
	13-15,5	40	A760 S20	A765 R1	12	CC..0602..	Steel shank with insert holder
	13-15,5	60	A760 E20	A765 R1	12	CC..0602..	Carbide shank with insert holder
	15,5-18	40	A760 S20	A765 R2	12	CC..0602..	Steel shank with insert holder
	15,5-18	60	A760 E20	A765 R2	12	CC..0602..	Carbide shank with insert holder
	18-20	40	A760 S20	A765 R3	12	CC..0602..	Steel shank with insert holder
	18-20	60	A760 E20	A765 R3	12	CC..0602..	Carbide shank with insert holder
A760 03/ A760 13	6-8	16	A762 003	–	16	WB..0301..	Steel, inserts type
	6-8	32	A762 203	–	16	WB..0301..	Carbide, inserts type
	8-10	22	A763 003	–	16	WB..0301..	Steel, inserts type
	8-10	37	A763 203	–	16	WB..0301..	Carbide, inserts type
	10-13	30	A765 003	–	16	CC..0602..	Steel, inserts type
	10-13	55	A765 203	–	16	CC..0602..	Carbide, inserts type
	13-15,5	40	A760 S30	A765 R1	16	CC..0602..	Steel shank with insert holder
	13-15,5	70	A760 E30	A765 R1	16	CC..0602..	Carbide shank with insert holder
	15,5-18	40	A760 S30	A765 R2	16	CC..0602..	Steel shank with insert holder
	15,5-18	70	A760 E30	A765 R2	16	CC..0602..	Carbide shank with insert holder
	18-20,5	50	A760 S31	A765 R1	16	CC..0602..	Steel shank with insert holder
	18-20,5	80	A760 E31	A765 R1	16	CC..0602..	Carbide shank with insert holder
	20,5-23	50	A760 S31	A765 R2	16	CC..0602..	Steel shank with insert holder
	20,5-23	80	A760 E31	A765 R2	16	CC..0602..	Carbide shank with insert holder
	23-25,5	50	A760 S31	A765 R3	16	CC..0602..	Steel shank with insert holder
	23-25,5	80	A760 E31	A765 R3	16	CC..0602..	Carbide shank with insert holder
	25,5-28	50	A760 S31	A765 R4	16	CC..0602..	Steel shank with insert holder
	25,5-28	80	A760 E31	A765 R4	16	CC..0602..	Carbide shank with insert holder
	28-30,5	50	A760 S31	A765 R5	16	CC..0602..	Steel shank with insert holder
	28-30,5	80	A760 E31	A765 R5	16	CC..0602..	Carbide shank with insert holder
	30,5-33	50	A760 S31	A765 R6	16	CC..0602..	Steel shank with insert holder
	30,5-33	80	A760 E31	A765 R6	16	CC..0602..	Carbide shank with insert holder
	33-35,5*	60	A760 A32	A765 R1	16	CC..0602..	Aluminium shank with insert holder
	35,5-38*	60	A760 A32	A765 R2	16	CC..0602..	Aluminium shank with insert holder
	38-40,5*	60	A760 A32	A765 R3	16	CC..0602..	Aluminium shank with insert holder
	40,5-43*	60	A760 A32	A765 R4	16	CC..0602..	Aluminium shank with insert holder
	43-45,5*	60	A760 A32	A765 R5	16	CC..0602..	Aluminium shank with insert holder
	45,5-48*	60	A760 A32	A765 R6	16	CC..0602..	Aluminium shank with insert holder
	48-50,5*	80	A760 A33	A765 R1	16	CC..0602..	Aluminium shank with insert holder
	50,5-53*	80	A760 A33	A765 R2	16	CC..0602..	Aluminium shank with insert holder
	53-55,5*	80	A760 A33	A765 R3	16	CC..0602..	Aluminium shank with insert holder
	55,5-58*	80	A760 A33	A765 R4	16	CC..0602..	Aluminium shank with insert holder
	58-60,5*	80	A760 A33	A765 R5	16	CC..0602..	Aluminium shank with insert holder
60,5-63*	80	A760 A33	A765 R6	16	CC..0602..	Aluminium shank with insert holder	

For larger diameters, see Multi-purpose adapter (MPA) section.

* When used on A760 13, no fine balancing possible.

Multi-purpose adapter (MPA), for EPB 760 heads



- Suitable for - Axiabore™ Plus - A760 03 head only*
- Designed to hold a shank and a counterweight (for boring or OD-overturning) or two grooving tool holders (for face grooving)
- Through coolant with an adjustable nozzle (3)

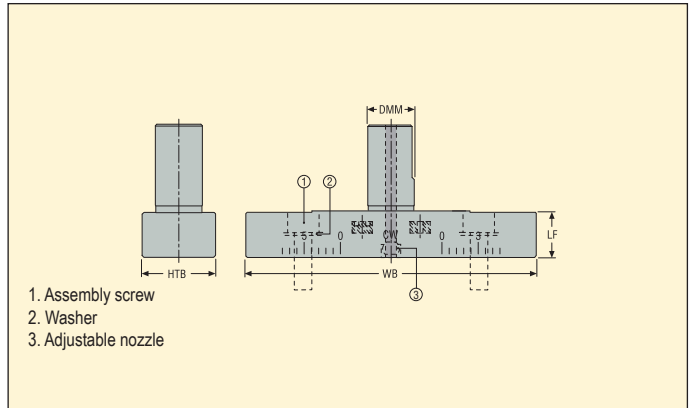

Capacity DCN-DCX Ø mm			Ordering and Product No.	Designation	Dimensions in mm				KG
For boring Ø (mm)	For OD-overturning Ø (mm)	For grooving Ø (mm)			HTB	DMM	WB	LF	
53,0-108,0	2,0-57,0	31,0-96,0	02595014	BDA16BS25100	25,0	16,0	100,0	16,0	0,28

*When used on an - Axialibrabore™ Plus - A760 13 head, no fine balancing possible, see page(s) 416.
 Select the required components to realise boring, OD-overturning or grooving assemblies, using following page(s) 429-434.

Spare Parts

For	Assembly screw	Washer
BDA16BS25100	950D0618	940ZC06

Accessories

Clamp key
03HL05

Please check availability in current price and stock-list
 Accessories not included in delivery.

Shank & counterweight, for boring or OD-overturning on a MPA, for EPB 760 heads



- For fitting on to the MPA
- Shank can be used for boring or OD-overturning
- Takes the same insert holders as the modular boring shanks

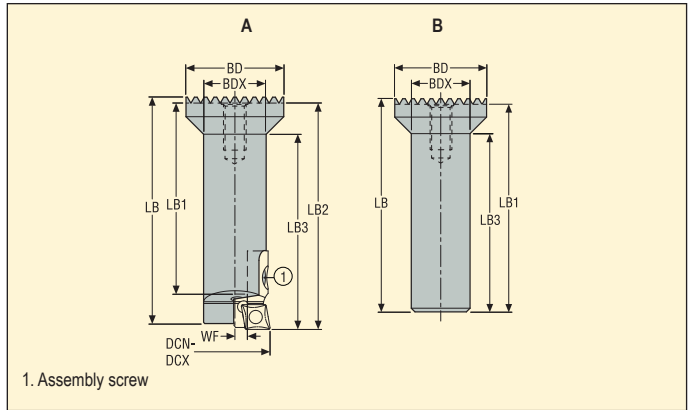

Type	Capacity DCN-DCX ∅ mm**		Ordering and Product No.	Designation	Dimensions in mm							Design	KG
	For boring ∅ (mm)	For OD-overturning ∅ (mm)			LB	LB1	LB2	LB3	WF	BDX	BD		
Shank*	53,0-108,0	2,0-57,0	02595019	BAS25MH1660	58,5	48,5	58,5	50,0	4,0	16,0	25,0	A	0,1
Counterweight	53,0-108,0	2,0-57,0	02595016	BAS25CW1660	58,0	56,6	–	48,5	–	16,0	25,0	B	0,11

*Insert holders to be ordered separately, see page(s) 423. **Capacities in boring and OD-overturning are related to the selected insert holder and the setting position of the shanks using the 'Insert holders for boring or OD-overturning selection chart' on page(s) 429-434.

Spare Parts

For	Assembly screw
BAS25CW1660	–
BAS25MH1660	C04008-T15P

Accessories

Clamp key
–
T15P-3

Please check availability in current price and stock-list
Accessories not included in delivery.

Grooving tool holders, for face grooving on a MPA, for EPB 760 heads



- For fitting on to the MPA
- A grooving tool holder is used either to hold a grooving tool, or to act as a counterweight

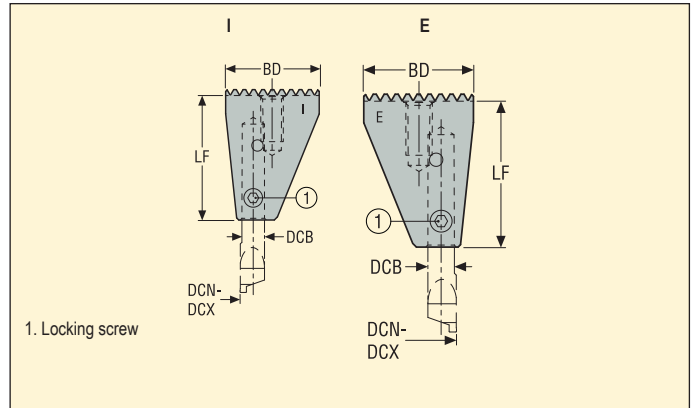

Type	Capacity DCN-DCX ∅ mm**	Ordering and Product No.	Designation	Dimensions in mm			Design	KG
				DCB	BD	LF		
Grooving tool holder I (internal)*	19,0-76,0	02595021	BAS25FGI35	6,0	25,0	34,0	I (Internal)	0,1
Grooving tool holder E (external)*	39,0-96,0	02595020	BAS25FGE35	6,0	25,0	34,0	E (External)	0,1

*Grooving tools to be ordered separately, see page(s) 428 *Capacity in grooving is related to the selected grooving tool, the setting position and orientation of the grooving tool holder, using the 'Grooving tool against spigot (or against bore) selection charts' see page(s) 431-434

Spare Parts

For	Locking screw
BAS25FGEI35	950L0607T15P
BAS25FGI35	950L0607T15P

Accessories

Locking key
T15P-3
T15P-3

Please check availability in current price and stock-list
Accessories not included in delivery.

Grooving tools, for EPB 760 heads

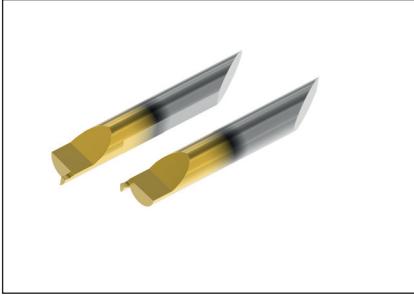

- Can be used for either 'external' or 'internal' grooving tool holders, depending on capacity

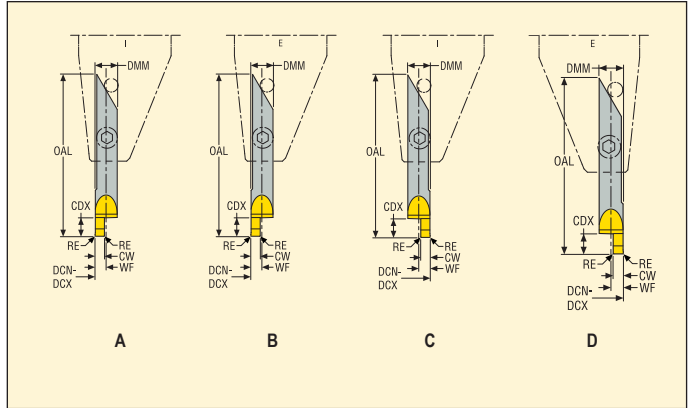

	Capacity DCN-DCX ∅ mm*					Ordering and Product No.	Designation	Dimensions in mm				Groove max. depth CDX	
	Design A	Design B	Design C	Design D	CW			OAL	WF	RE	DMM		
Grooving tool -against spigot-	19,0-64,0	39,0-84,0	-	-	1,0	02595028	AFG0629101582	42,0	2,95	0,15	6,0	2,0	0,07
	19,0-64,0	39,0-84,0	-	-	1,5	02595029	AFG0629151582	42,0	2,95	0,15	6,0	3,0	0,07
	19,0-64,0	39,0-84,0	-	-	2,0	02595031	AFG0629201582	42,0	2,95	0,15	6,0	5,0	0,07
	19,0-64,0	39,0-84,0	-	-	2,5	02595032	AFG0629251582	42,0	2,95	0,15	6,0	5,0	0,07
	19,0-64,0	39,0-84,0	-	-	3,0	02595033	AFG0629301582	42,0	2,95	0,15	6,0	6,0	0,07
Grooving tool -against bore-	-	-	31,0-76,0	51,0-96,0	1,0	02595022	AFG0629101581	42,0	2,95	0,15	6,0	2,0	0,02
	-	-	31,0-76,0	51,0-96,0	1,5	02595023	AFG0629151581	42,0	2,95	0,15	6,0	3,0	0,07
	-	-	31,0-76,0	51,0-96,0	2,0	02595024	AFG0629201581	42,0	2,95	0,15	6,0	4,0	0,07
	-	-	31,0-76,0	51,0-96,0	2,5	02595026	AFG0629251581	42,0	2,95	0,15	6,0	5,0	0,07
	-	-	31,0-76,0	51,0-96,0	3,0	02595027	AFG0629301581	42,0	2,95	0,15	6,0	6,0	0,07

*Capacity in grooving is related to the selected grooving tool, the setting position and orientation of the grooving tool holder, using the ' Grooving tool against spigot (or against bore) selection charts' see page(s) 431-434.

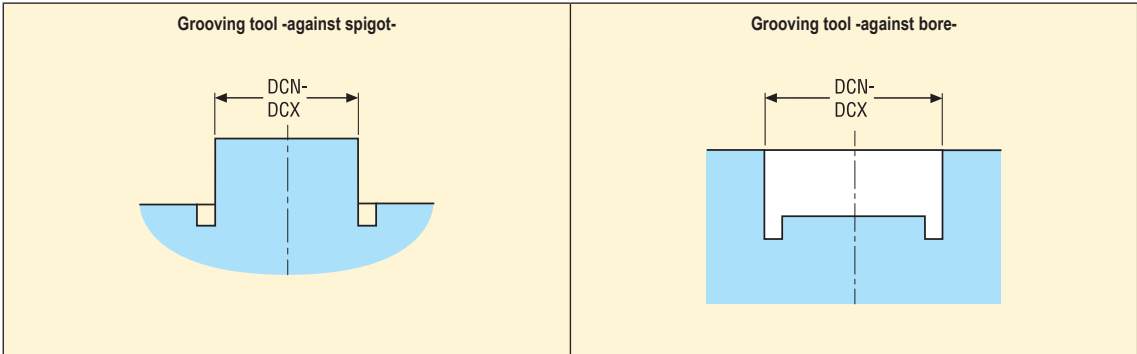

Please check availability in current price and stock-list

Selection chart: Boring tools and insert holders suitable for EPB 760 heads

Select a suitable insert holder, and note the shank position on the MPA to obtain the required bore capacity.
 Note: A OD-overturning assembly requires :
 - an - Axiabore™ Plus - head (A760 03)
 - a MPA (BDA16BS25100)
 - a shank (BAS25MH1660)
 - a counterweight (BAS25CW1660).
 - an insert holder (A765R.) to be selected in the chart
 - an insert

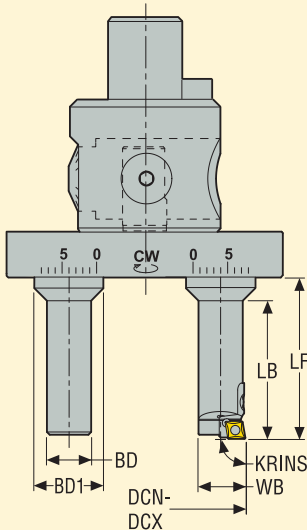

Capacity DCN-DCX Ø mm	Insert holder Designation	Shank position	Dimensions in mm					Lead angle KRINS°	Suitable insert size
			BD	BD1	LF	LB	WB		
53-55,5	A765 R1	0	16	25	58,5	50	17	90°	CC..0602..
55,5-58	A765 R2	0	16	25	58,5	50	18,2	90°	CC..0602..
58-60,5	A765 R1	1	16	25	58,5	50	17	90°	CC..0602..
	A765 R3	0	16	25	58,5	50	19,5	90°	CC..0602..
60,5-63	A765 R2	1	16	25	58,5	50	18,2	90°	CC..0602..
	A765 R4	0	16	25	58,5	50	20,7	90°	CC..0602..
63-65,5	A765 R1	2	16	25	58,5	50	17	90°	CC..0602..
	A765 R3	1	16	25	58,5	50	19,5	90°	CC..0602..
	A765 R5	0	16	25	58,5	50	22	90°	CC..0602..
65,5-68	A765 R2	2	16	25	58,5	50	18,2	90°	CC..0602..
	A765 R4	1	16	25	58,5	50	20,7	90°	CC..0602..
	A765 R6	0	16	25	58,5	50	23,3	90°	CC..0602..
68-70,5	A765 R1	3	16	25	58,5	50	17	90°	CC..0602..
	A765 R3	2	16	25	58,5	50	19,5	90°	CC..0602..
	A765 R5	1	16	25	58,5	50	22	90°	CC..0602..
70,5-73	A765 R2	3	16	25	58,5	50	18,2	90°	CC..0602..
	A765 R4	2	16	25	58,5	50	20,7	90°	CC..0602..
	A765 R6	1	16	25	58,5	50	23,2	90°	CC..0602..
73-75,5	A765 R1	4	16	25	58,5	50	17	90°	CC..0602..
	A765 R3	3	16	25	58,5	50	19,5	90°	CC..0602..
	A765 R5	2	16	25	58,5	50	22	90°	CC..0602..
75,5-78	A765 R2	4	16	25	58,5	50	18,2	90°	CC..0602..
	A765 R4	3	16	25	58,5	50	20,7	90°	CC..0602..
	A765 R6	2	16	25	58,5	50	23,2	90°	CC..0602..
78-80,5	A765 R1	5	16	25	58,5	50	17	90°	CC..0602..
	A765 R3	4	16	25	58,5	50	19,5	90°	CC..0602..
	A765 R5	3	16	25	58,5	50	22	90°	CC..0602..
80,5-83	A765 R2	5	16	25	58,5	50	18,2	90°	CC..0602..
	A765 R4	4	16	25	58,5	50	20,7	90°	CC..0602..
	A765 R6	3	16	25	58,5	50	23,2	90°	CC..0602..
83-85,5	A765 R1	6	16	25	58,5	50	17	90°	CC..0602..
	A765 R3	5	16	25	58,5	50	19,5	90°	CC..0602..
	A765 R5	4	16	25	58,5	50	22	90°	CC..0602..
85,5-88	A765 R2	6	16	25	58,5	50	18,2	90°	CC..0602..
	A765 R4	5	16	25	58,5	50	20,7	90°	CC..0602..
	A765 R6	4	16	25	58,5	50	23,2	90°	CC..0602..
88-90,5	A765 R1	7	16	25	58,5	50	17	90°	CC..0602..
	A765 R3	6	16	25	58,5	50	19,5	90°	CC..0602..
	A765 R5	5	16	25	58,5	50	22	90°	CC..0602..
90,5-93	A765 R2	7	16	25	58,5	50	18,2	90°	CC..0602..
	A765 R4	6	16	25	58,5	50	20,7	90°	CC..0602..
	A765 R6	5	16	25	58,5	50	23,2	90°	CC..0602..
93-95,5	A765 R1	8	16	25	58,5	50	17	90°	CC..0602..
	A765 R3	7	16	25	58,5	50	19,5	90°	CC..0602..
	A765 R5	6	16	25	58,5	50	22	90°	CC..0602..
95,5-98	A765 R2	8	16	25	58,5	50	18,2	90°	CC..0602..
	A765 R4	7	16	25	58,5	50	20,7	90°	CC..0602..
	A765 R6	6	16	25	58,5	50	23,2	90°	CC..0602..
98-100,5	A765 R3	8	16	25	58,5	50	19,5	90°	CC..0602..
	A765 R5	7	16	25	58,5	50	22	90°	CC..0602..
	A765 R4	8	16	25	58,5	50	20,7	90°	CC..0602..
100,5-103	A765 R6	7	16	25	58,5	50	23,2	90°	CC..0602..
	A765 R5	8	16	25	58,5	50	22	90°	CC..0602..
103-105,5	A765 R5	8	16	25	58,5	50	22	90°	CC..0602..
105,5-108	A765 R6	8	16	25	58,5	50	23,2	90°	CC..0602..

* +0,2 mm complementary capacity achievable.
 Detailed description of insert holders, see page(s) 423.

Selection chart: Insert holders for OD-overturning with MPA, for EPB 760 heads

Select a suitable insert holder, and note the shank position on the MPA to obtain the required bore capacity.
 Note: A OD-overturning assembly requires :
 - an - Axiabore™ Plus - head (A760 03)
 - a MPA (BDA16BS25100)
 - a shank (BAS25MH1660)
 - a counterweight (BAS25CW1660).
 - an insert holder (A765R.) to be selected in the chart
 - an insert

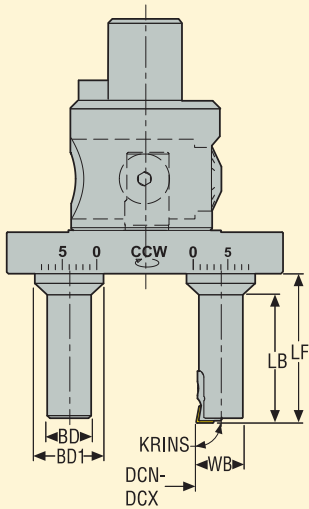

Capacity DCN-DCX Ø mm	Insert holder Designation	Shank position	Dimensions in mm					Lead angle KRINS°	Suitable insert size
			BD	BD1	LF	LB	WB		
2-4,5	A765 R6	0	16	25	58,5	50	23,2	90°	CC..0602..
4,5-7	A765 R5	0	16	25	58,5	50	22	90°	CC..0602..
7-9,5	A765 R6	1	16	25	58,5	50	23,2	90°	CC..0602..
	A765 R4	0	16	25	58,5	50	20,7	90°	CC..0602..
9,5-12	A765 R5	1	16	25	58,5	50	22	90°	CC..0602..
	A765 R3	0	16	25	58,5	50	19,5	90°	CC..0602..
12-14,5	A765 R6	2	16	25	58,5	50	23,2	90°	CC..0602..
	A765 R4	1	16	25	58,5	50	20,7	90°	CC..0602..
	A765 R2	0	16	25	58,5	50	18,2	90°	CC..0602..
14,5-17	A765 R5	2	16	25	58,5	50	22	90°	CC..0602..
	A765 R3	1	16	25	58,5	50	19,5	90°	CC..0602..
	A765 R1	0	16	25	58,5	50	17	90°	CC..0602..
	A765 R6	3	16	25	58,5	50	23,2	90°	CC..0602..
17-19,5	A765 R4	2	16	25	58,5	50	20,7	90°	CC..0602..
	A765 R2	1	16	25	58,5	50	18,2	90°	CC..0602..
	A765 R5	3	16	25	58,5	50	22	90°	CC..0602..
19,5-22	A765 R3	2	16	25	58,5	50	19,5	90°	CC..0602..
	A765 R1	1	16	25	58,5	50	17	90°	CC..0602..
	A765 R6	4	16	25	58,5	50	23,2	90°	CC..0602..
22-24,5	A765 R4	3	16	25	58,5	50	20,7	90°	CC..0602..
	A765 R2	2	16	25	58,5	50	18,2	90°	CC..0602..
	A765 R5	4	16	25	58,5	50	22	90°	CC..0602..
24,5-27	A765 R3	3	16	25	58,5	50	19,5	90°	CC..0602..
	A765 R1	2	16	25	58,5	50	17	90°	CC..0602..
	A765 R6	5	16	25	58,5	50	23,2	90°	CC..0602..
27-29,5	A765 R4	4	16	25	58,5	50	20,7	90°	CC..0602..
	A765 R2	3	16	25	58,5	50	18,2	90°	CC..0602..
	A765 R5	5	16	25	58,5	50	22	90°	CC..0602..
29,5-32	A765 R3	4	16	25	58,5	50	19,5	90°	CC..0602..
	A765 R1	3	16	25	58,5	50	17	90°	CC..0602..
	A765 R6	6	16	25	58,5	50	23,2	90°	CC..0602..
32-34,5	A765 R4	5	16	25	58,5	50	20,7	90°	CC..0602..
	A765 R2	4	16	25	58,5	50	18,2	90°	CC..0602..
	A765 R5	6	16	25	58,5	50	22	90°	CC..0602..
34,5-37	A765 R3	5	16	25	58,5	50	19,5	90°	CC..0602..
	A765 R1	4	16	25	58,5	50	17	90°	CC..0602..
	A765 R6	7	16	25	58,5	50	23,2	90°	CC..0602..
37-39,5	A765 R4	6	16	25	58,5	50	20,7	90°	CC..0602..
	A765 R2	5	16	25	58,5	50	18,2	90°	CC..0602..
	A765 R5	7	16	25	58,5	50	22	90°	CC..0602..
39,5-42	A765 R3	6	16	25	58,5	50	19,5	90°	CC..0602..
	A765 R1	5	16	25	58,5	50	17	90°	CC..0602..
	A765 R6	8	16	25	58,5	50	23,2	90°	CC..0602..
42-44,5	A765 R4	7	16	25	58,5	50	20,7	90°	CC..0602..
	A765 R2	6	16	25	58,5	50	18,2	90°	CC..0602..
	A765 R5	8	16	25	58,5	50	22	90°	CC..0602..
44,5-47	A765 R3	7	16	25	58,5	50	19,5	90°	CC..0602..
	A765 R1	6	16	25	58,5	50	17	90°	CC..0602..
	A765 R4	8	16	25	58,5	50	20,7	90°	CC..0602..
47-49,5	A765 R2	7	16	25	58,5	50	18,2	90°	CC..0602..
	A765 R3	8	16	25	58,5	50	19,5	90°	CC..0602..
49,5-52	A765 R1	7	16	25	58,5	50	17	90°	CC..0602..
52-54,5	A765 R2	8	16	25	58,5	50	18,2	90°	CC..0602..
54,5-57	A765 R1	8	16	25	58,5	50	17	90°	CC..0602..

* +0,2 mm complementary capacity achievable.
 Detailed description of insert holders, see page(s) 423.

Selection chart: Grooving tool -against spigot- for grooving with MPA, for EPB 760 heads

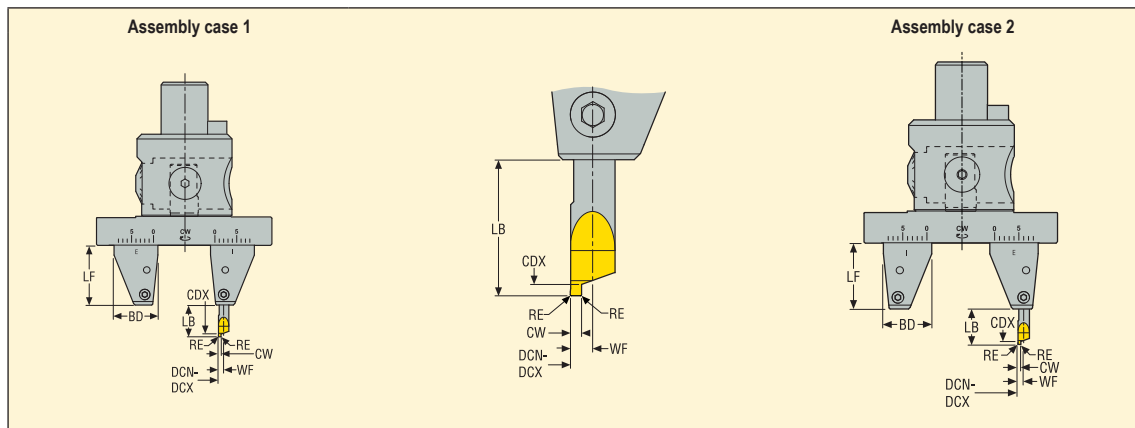

Select the suitable grooving tool, and note the grooving tool holder position on the MPA to obtain the required groove capacity.	CW	Capacity DCN-DCX Ø mm*	Against spigot grooving tool Designation	Grooving toolholder position**	Design	Dimensions in mm					Groove max. depth CDX	
						BD	LF	LB	WF	RE		
	1	19-24	AFG0629 10 1582	0-I	1	25	34	18	2,95	0,15	2	
	1	24-29		1-I	1	25	34	18	2,95	0,15	2	
	1	29-34		2-I	1	25	34	18	2,95	0,15	2	
	1	34-39		3-I	1	25	34	18	2,95	0,15	2	
	1	39-44		0-E / 4-I	1/2	25	34	18	2,95	0,15	2	
	1	44-49		1-E / 5-I	1/2	25	34	18	2,95	0,15	2	
	1	49-54		2-E / 6-I	1/2	25	34	18	2,95	0,15	2	
	1	54-59		3-E / 7-I	1/2	25	34	18	2,95	0,15	2	
	1	59-64		4-E / 8-I	1/2	25	34	18	2,95	0,15	2	
	1	64-69		5-E	2	25	34	18	2,95	0,15	2	
	1	69-74		6-E	2	25	34	18	2,95	0,15	2	
	1	74-79		7-E	2	25	34	18	2,95	0,15	2	
	1	79-84		8-E	2	25	34	18	2,95	0,15	2	
	1,5	19-24		AFG0629 15 1582	0-I	1	25	34	18	2,95	0,15	3
	1,5	24-29			1-I	1	25	34	18	2,95	0,15	3
1,5	29-34	2-I	1		25	34	18	2,95	0,15	3		
1,5	34-39	3-I	1		25	34	18	2,95	0,15	3		
1,5	39-44	0-E / 4-I	1/2		25	34	18	2,95	0,15	3		
1,5	44-49	1-E / 5-I	1/2		25	34	18	2,95	0,15	3		
1,5	49-54	2-E / 6-I	1/2		25	34	18	2,95	0,15	3		
1,5	54-59	3-E / 7-I	1/2		25	34	18	2,95	0,15	3		
1,5	59-64	4-E / 8-I	1/2		25	34	18	2,95	0,15	3		
1,5	64-69	5-E	2		25	34	18	2,95	0,15	3		
1,5	69-74	6-E	2		25	34	18	2,95	0,15	3		
1,5	74-79	7-E	2		25	34	18	2,95	0,15	3		
1,5	79-84	8-E	2		25	34	18	2,95	0,15	3		
2	19-24	AFG0629 20 1582	0-I		1	25	34	18	2,95	0,15	4	
2	24-29		1-I		1	25	34	18	2,95	0,15	4	
2	29-34		2-I	1	25	34	18	2,95	0,15	4		
2	34-39		3-I	1	25	34	18	2,95	0,15	4		
2	39-44		0-E / 4-I	1/2	25	34	18	2,95	0,15	4		
2	44-49		1-E / 5-I	1/2	25	34	18	2,95	0,15	4		
2	49-54		2-E / 6-I	1/2	25	34	18	2,95	0,15	4		
2	54-59		3-E / 7-I	1/2	25	34	18	2,95	0,15	4		
2	59-64		4-E / 8-I	1/2	25	34	18	2,95	0,15	4		
2	64-69		5-E	2	25	34	18	2,95	0,15	4		
2	69-74		6-E	2	25	34	18	2,95	0,15	4		
2	74-79		7-E	2	25	34	18	2,95	0,15	4		
2	79-84		8-E	2	25	34	18	2,95	0,15	4		

* +0,2 mm complementary capacity achievable. ** Recommended values in bold.

Detailed description of the grooving tools, see page(s) 428.

Selection chart: Grooving tool -against spigot- for grooving with MPA, for EPB 760 heads (cont.)

		Assembly case 1				Assembly case 2						
<p>Select the suitable grooving tool, and note the grooving tool holder position on the MPA to obtain the required groove capacity.</p> <p>Note : An -against spigot- grooving assembly requires :</p> <ul style="list-style-type: none"> - an - Axiabore™ Plus - head (A760 03) - a MPA (BDA16BS25100) - an I (internal position) and an E (external position) grooving tool holder (BAS25FGI35 and BAS25FGE35) to either hold a grooving tool or act as a counterweight (see setting position in the chart) - an -against spigot- grooving tool (AFG...82) to be selected from the chart, related to groove width and diameter. 	CW	Capacity DCN-DCX Ø mm	Against spigot grooving tool Designation	Grooving toolholder position**	Design	Dimensions in mm					Groove max. depth CDX	
	BD	LF	LB	WF	RE							
		2,5	19-24	AFG0629 25 1582	0-I	1	25	34	18	2,95	0,15	5
		2,5	24-29		1-I	1	25	34	18	2,95	0,15	5
		2,5	29-34		2-I	1	25	34	18	2,95	0,15	5
		2,5	34-39		3-I	1	25	34	18	2,95	0,15	5
		2,5	39-44		0-E / 4-I	1/2	25	34	18	2,95	0,15	5
		2,5	44-49		1-E / 5-I	1/2	25	34	18	2,95	0,15	5
		2,5	49-54		2-E / 6-I	1/2	25	34	18	2,95	0,15	5
		2,5	54-59		3-E / 7-I	1/2	25	34	18	2,95	0,15	5
		2,5	59-64		4-E / 8-I	1/2	25	34	18	2,95	0,15	5
		2,5	64-69		5-E	2	25	34	18	2,95	0,15	5
		2,5	69-74		6-E	2	25	34	18	2,95	0,15	5
		2,5	74-79		7-E	2	25	34	18	2,95	0,15	5
		2,5	79-84	8-E	2	25	34	18	2,95	0,15	5	
		3	19-24	AFG0629 30 1582	0-I	1	25	34	18	2,95	0,15	6
		3	24-29		1-I	1	25	34	18	2,95	0,15	6
		3	29-34		2-I	1	25	34	18	2,95	0,15	6
		3	34-39		3-I	1	25	34	18	2,95	0,15	6
		3	39-44		0-E / 4-I	1/2	25	34	18	2,95	0,15	6
		3	44-49		1-E / 5-I	1/2	25	34	18	2,95	0,15	6
		3	49-54		2-E / 6-I	1/2	25	34	18	2,95	0,15	6
		3	54-59		3-E / 7-I	1/2	25	34	18	2,95	0,15	6
		3	59-64	4-E / 8-I	1/2	25	34	18	2,95	0,15	6	
		3	64-69	5-E	2	25	34	18	2,95	0,15	6	
	3	69-74	6-E	2	25	34	18	2,95	0,15	6		
	3	74-79	7-E	2	25	34	18	2,95	0,15	6		
	3	79-84	8-E	2	25	34	18	2,95	0,15	6		

* +0,2 mm complementary capacity achievable. ** Recommended values in bold.

Detailed description of the grooving tools, see page(s) 428.

Selection chart: Grooving tool -against bore- for grooving with MPA, for EPB 760 heads

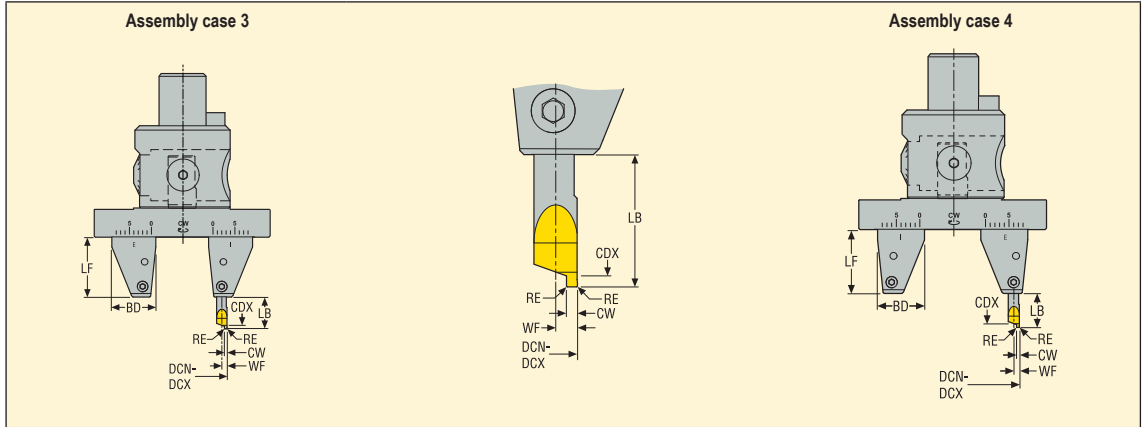

CW	Capacity DCN-DCX Ø mm	Against bore grooving tool Designation	Grooving toolholder position**	Design	Dimensions in mm					Groove max. depth CDX
					BD	LF	LB	WF	RE	
1	31-36	AFG0629 10 1581	0-I	3	25	34	18	2,95	0,15	2
1	36-41		1-I	3	25	34	18	2,95	0,15	2
1	41-46		2-I	3	25	34	18	2,95	0,15	2
1	46-51		3-I	3	25	34	18	2,95	0,15	2
1	51-56		0-E / 4-I	3/4	25	34	18	2,95	0,15	2
1	56-61		1-E / 5-I	3/4	25	34	18	2,95	0,15	2
1	61-66		2-E / 6-I	3/4	25	34	18	2,95	0,15	2
1	66-71		3-E / 7-I	3/4	25	34	18	2,95	0,15	2
1	71-76		4-E / 8-I	3/4	25	34	18	2,95	0,15	2
1	76-81		5-E	4	25	34	18	2,95	0,15	2
1	81-86		6-E	4	25	34	18	2,95	0,15	2
1	86-91		7-E	4	25	34	18	2,95	0,15	2
1	91-96		8-E	4	25	34	18	2,95	0,15	2
1,5	31-36		AFG0629 15 1581	0-I	3	25	34	18	2,95	0,15
1,5	39-41	1-I		3	25	34	18	2,95	0,15	3
1,5	41-46	2-I		3	25	34	18	2,95	0,15	3
1,5	46-51	3-I		3	25	34	18	2,95	0,15	3
1,5	51-56	0-E / 4-I		3/4	25	34	18	2,95	0,15	3
1,5	56-61	1-E / 5-I		3/4	25	34	18	2,95	0,15	3
1,5	61-66	2-E / 6-I		3/4	25	34	18	2,95	0,15	3
1,5	66-71	3-E / 7-I		3/4	25	34	18	2,95	0,15	3
1,5	71-76	4-E / 8-I		3/4	25	34	18	2,95	0,15	3
1,5	76-81	5-E		4	25	34	18	2,95	0,15	3
1,5	81-86	6-E		4	25	34	18	2,95	0,15	3
1,5	86-91	7-E		4	25	34	18	2,95	0,15	3
1,5	91-96	8-E		4	25	34	18	2,95	0,15	3
2	31-36	AFG0629 20 1581		0-I	3	25	34	18	2,95	0,15
2	39-41		1-I	3	25	34	18	2,95	0,15	4
2	41-46		2-I	3	25	34	18	2,95	0,15	4
2	46-51		3-I	3	25	34	18	2,95	0,15	4
2	51-56		0-E / 4-I	3/4	25	34	18	2,95	0,15	4
2	56-61		1-E / 5-I	3/4	25	34	18	2,95	0,15	4
2	61-66		2-E / 6-I	3/4	25	34	18	2,95	0,15	4
2	66-71		3-E / 7-I	3/4	25	34	18	2,95	0,15	4
2	71-76		4-E / 8-I	3/4	25	34	18	2,95	0,15	4
2	76-81		5-E	4	25	34	18	2,95	0,15	4
2	81-86		6-E	4	25	34	18	2,95	0,15	4
2	86-91		7-E	4	25	34	18	2,95	0,15	4
2	91-96		8-E	4	25	34	18	2,95	0,15	4

Select the suitable grooving tool, and note the grooving tool holder position on the MPA to obtain the required groove capacity.

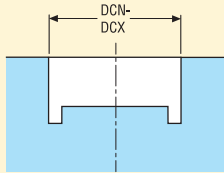

Note : An -against bore- grooving assembly requires :

- an -Axiabore™ Plus - head (A760 03)
- a MPA (BDA16BS25100)
- an I (internal position) and an E (external position) grooving tool holder (BAS25FGI35 and BAS25FGE35) to either hold a grooving tool or act as a counterweight (see setting position in the chart)
- an -against bore- grooving tool (AFG...82) to be selected from the chart, related to groove width and diameter.

* +0,2 mm complementary capacity achievable. ** Recommended values in bold.
Detailed description of the grooving tools, see page(s) 428.

Selection chart: Grooving tool -against bore- for grooving with MPA, for EPB 760 heads

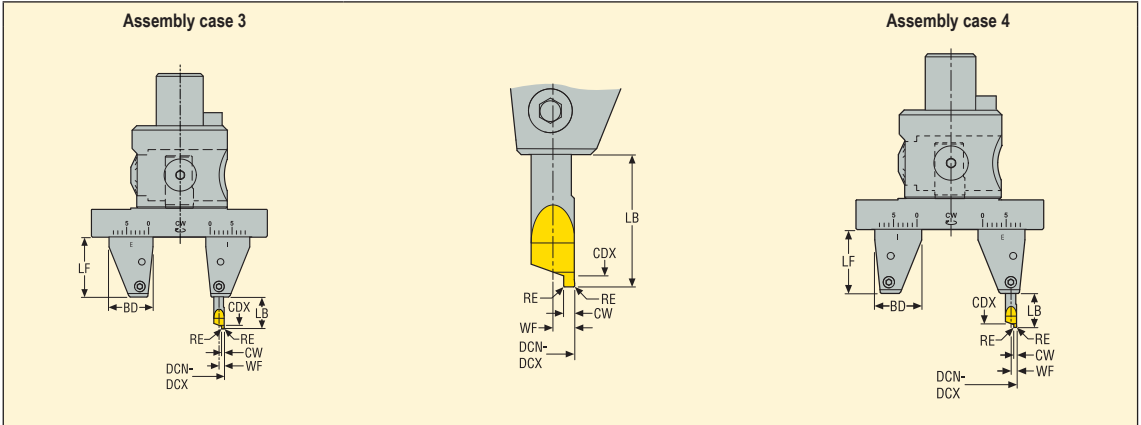

Select the suitable grooving tool, and note the grooving tool holder position on the MPA to obtain the required groove capacity.	CW	Capacity DCN-DCX \varnothing mm	Against bore grooving tool Designation	Grooving toolholder position**	Design	Dimensions in mm					Groove max. depth CDX
						BD	LF	LB	WF	RE	
<p>Note : An -against bore- grooving assembly requires :</p> <ul style="list-style-type: none"> - an - Axiabore™ Plus - head (A760 03) - a MPA (BDA16BS25100) - an I (internal position) and an E (external position) grooving tool holder (BAS25FGI35 and BAS25FGE35) to either hold a grooving tool or act as a counterweight (see setting position in the chart) - an -against bore- grooving tool (AFG...82) to be selected from the chart, related to groove width and diameter. 	2,5	31-36	AFG0629 25 1581	0-I	3	25	34	18	2,95	0,15	5
	2,5	36-41		1-I	3	25	34	18	2,95	0,15	5
	2,5	41-46		2-I	3	25	34	18	2,95	0,15	5
	2,5	46-51		3-I	3	25	34	18	2,95	0,15	5
	2,5	51-56		0-E / 4-I	3/4	25	34	18	2,95	0,15	5
	2,5	56-61		1-E / 5-I	3/4	25	34	18	2,95	0,15	5
	2,5	61-66		2-E / 6-I	3/4	25	34	18	2,95	0,15	5
	2,5	66-71		3-E / 7-I	3/4	25	34	18	2,95	0,15	5
	2,5	71-76		4-E / 8-I	3/4	25	34	18	2,95	0,15	5
	2,5	76-81		5-E	4	25	34	18	2,95	0,15	5
	2,5	81-86	6-E	4	25	34	18	2,95	0,15	5	
	2,5	86-91	7-E	4	25	34	18	2,95	0,15	5	
	2,5	91-96	8-E	4	25	34	18	2,95	0,15	5	
	3	31-36	AFG0629 30 1581	0-I	3	25	34	18	2,95	0,15	6
	3	39-41		1-I	3	25	34	18	2,95	0,15	6
	3	41-46		2-I	3	25	34	18	2,95	0,15	6
	3	46-51		3-I	3	25	34	18	2,95	0,15	6
	3	51-56		0-E / 4-I	3/4	25	34	18	2,95	0,15	6
	3	56-61		1-E / 5-I	3/4	25	34	18	2,95	0,15	6
	3	61-66		2-E / 6-I	3/4	25	34	18	2,95	0,15	6
3	66-71	3-E / 7-I		3/4	25	34	18	2,95	0,15	6	
3	71-76	4-E / 8-I		3/4	25	34	18	2,95	0,15	6	
3	76-81	5-E		4	25	34	18	2,95	0,15	6	
3	81-86	6-E	4	25	34	18	2,95	0,15	6		
3	86-91	7-E	4	25	34	18	2,95	0,15	6		
3	91-96	8-E	4	25	34	18	2,95	0,15	6		

* +0,2 mm complementary capacity achievable. ** Recommended values in bold.

Detailed description of the grooving tools, see page(s) 428.

Instructions – Maximum speeds for Axiabore™ type heads

For further application details refer to the operating instructions supplied with the boring heads and with the GL bars.

Head	Capacity mm	Max. RPM with tool (RPM)	Max. RPM with MPA (RPM)	Max. cutting speed v_c at min. Cap. (m/min)	Max. cutting speed v_c at max. Cap. (m/min)
Axiabore™ type with Graflex® connection					
A76001	0,3 – 8	30000	-	28*	754*
A76002	2 – 20	12000	-	75*	754*
A76003	6 – 108	8000**	5000	151*	1000***
A76012	2 – 20	24000**	-	151*	1500***
A76013	6 – 33	20000**	5000	377*	1500***
Axiabore™ type with Seco-Capto™ connection					
C3-391.0760-02	2-20	12000	-	75*	754*
C5-391.0760-03	6-108	8000**	5000	151*	1000**

Note: The maximum speeds are related to the boring head's mechanical design and balancing quality. Speeds inside these limits have to be chosen in regard to the other machining conditions, e.g. workpiece material, cutting edge (tools and inserts), tooling length, machine spindle. At speeds from approx. 8000 RPM and above, the holding arbors and intermediates should be fine balanced. Using balanceable heads and fine balanced holders improves the tool life and the boring performances even at lower speeds.

* Implied max. cutting speed with max. RPM.

** Not reachable with all tools, see ***.

*** Max. cutting speed not to be exceeded.

Troubleshooting

Problem	Possible cause	Solution
Poor tool life	Wrong insert grade	Change to more wear resistant grade
	Excessive cutting speed	Reduce cutting speed
	Excessive DOC	Decrease DOC
Chatter & Vibrations	Excessive cutting speed	Reduce cutting speed
	High L/D ratio	Shorten tool to increase stiffness
		Use stronger boring tool
		Use Steadyline bar
		Use carbide or heavy metal extensions
	Wrong insert	Reduce nose radius of insert
Use ground geometry inserts		
Incorrect stock allowance	Change pre-hole diameter	
Poor hole diameter tolerance & repeatability	Inaccurate tool changes	Worn and damaged tool shank: replace
		Clean spindle and tool shank
	Variation of stock allowance	Add semi-finishing boring step
	Low spindle stability	Use sharper ground geometry inserts
Poor roundness	Excessive boring tool imbalance	Check the spindle runout
		Change to LIBRAFLEX® boring head
		Check balance ring setting
		Reduce speed
	Excessive cutting forces	Check stock allowance and feed rate
	Insufficient workpiece clamping	Check for uniform workpiece clamping
	Workpiece non-symmetrical	Reduce cutting forces, change to ground insert
		Increase cutting speed, reduce feed
Poor positional tolerance	Original bore misaligned	Add a semi-finishing boring step
	Excessive DOC	Decrease DOC, make two passes
Poor surface finish	Wrong insert radius	Use larger insert radius
	Excessive feed rate	Reduce feed to be max. 30% of insert nose radius
	Poor chip evacuation	Apply through coolant
		Change insert to higher rake angle (HSS: please enquire)
		Check DOC
Tapered bore	Premature tool wear	Change to more wear resistant grade
		Modify cutting speed
		Increase coolant flow

Troubleshooting advice is also valid for the fine boring heads, radial type.



Fine boring heads – Overview

Graflex®

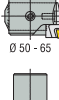
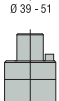
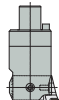
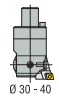

Graflex® balanceable

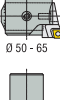
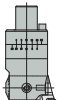

Seco-Capto™

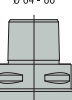
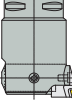
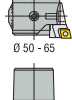
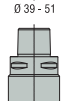
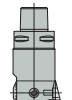

GL connection

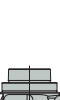

BA connection

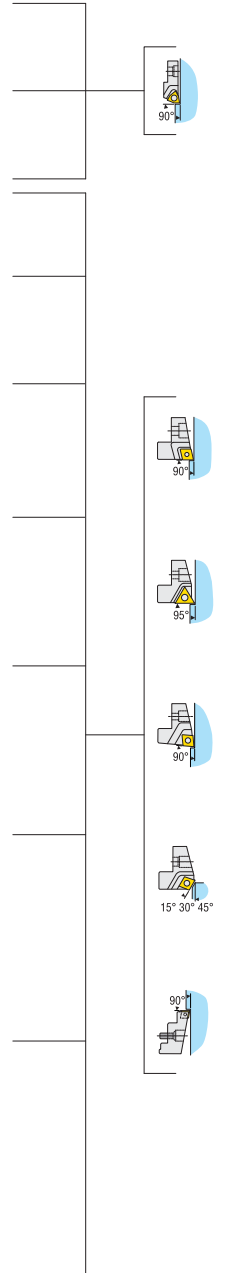
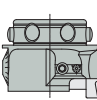

Features

A radial type fine boring head is an assembly of a body (head) and an insert holder. EPB 620, EPB 780 and EPB 790 radial, fine boring heads feature:

- Micrometric adjustment: Insert holder setting mechanism with a micrometric adjusting screw (1 increment = 0,01 mm on the diameter) and a vernier scale (resolution of 2,5 μm on the diameter)
- The precision of the mechanism guarantees repeatable accuracy
- Angular orientation of the cutting edge according to DIN 69871/ISO 7388 for SA and ISO 12164 for HSK
- Coolant through the head directed towards the cutting edge
- EPB 780 and EPB 620 boring heads are pre-balanced on median diameter setting. EPB 790 are balanceable, for optimized performance.



Note: Features, Instructions (insert holder fitting, diameter setting, back boring instructions, troubleshooting, recommended machining conditions, maximum speeds), **suitable insert holders and suitable** inserts are identical for all types of EPB 620, EPB 780 and EPB 790 fine boring heads of similar boring capacity size, regardless of their machine side connection types.

Product range

Seco offers a variety of radial fine boring heads to fulfill all your needs with the most suitable solution:

EPB 620 Fine boring heads, radial types, for Steadyline® vibration damping bars

- 3 fine boring heads with GL machine side connection for fine boring \varnothing 34 to 69 mm.
- 2 fine boring heads with BA machine side connection for fine boring \varnothing 66 to 116 mm.

Their compact design achieves best damping performances when used on Steadyline® GL turning and boring bars.



EPB 780 Fine boring heads, radial types

9 precision boring heads with Graflex® machine side connection for fine boring $\varnothing 15$ to 205 using radially fitted insert holders.

5 precision boring heads with Seco-Capto™ machine side connection for fine boring $\varnothing 39$ to 205 mm."

Seco-Capto™ adapter and Graflex® head: 15-40 mm

Note: The minimum bore size of the smallest Seco-Capto™ fine boring head is $\varnothing 39$ mm with the smallest available Seco-Capto™ C3 connection. For $\varnothing 15$ -40 mm use Graflex® boring heads with connection sizes G0 to G2 in conjunction with the appropriate Seco-Capto™/Graflex® adaptor. This offers also boring length modularity when using additional Graflex® extensions.

Note: Features, Instructions (insert holder fitting, diameter setting, back boring instructions, troubleshooting, recommended machining conditions, maximum speeds), suitable insert holders and suitable inserts are similar for both types of EPB 780 fine boring heads of similar boring capacity size, regardless of connection type.

EPB 790 Balanceable fine boring heads, radial type

5 balanceable 'Libraflex®' boring heads with Graflex® machine side connection for fine boring $\varnothing 30$ to 115 mm, at high speeds (up to 1500 m/min), using radially fitted insert holders.

Balancing reduces spindle stress, cutting parameters can be optimized, better machining qualities are achieved even at conventional speeds. Balancing is performed by setting both graduated rings in accordance with the diameter to be bored (no chart needed).



Features

Insert holders

A radial type fine boring head is an assembly of a body (head) and an insert holder.

The wide range of fine boring, chamfering and back boring insert holders are suitable for EPB 620, EPB 780 and EPB 790 fine boring heads, radial types.

Fine boring insert holders

EPB 782: lead angle 90° for WB inserts

EPB 724: lead angle 90° for TC inserts

EPB 725: lead angle 90° for CC inserts

EPB 726: lead angle 95° for CC inserts

Note: 95° lead angle insert holders should be used to avoid face contact when boring up a shoulder.

Chamfering insert holders, 23 to 160 mm

EPB 729: available with a 15°, 30° or 45° lead angle for CC inserts.

Libraflex® balancing can also be achieved when using chamfering insert holders.

Back-boring insert holders, 26,5 to 164 mm

EPB A789: lead angle 90° for WB and CC inserts..

Libraflex® balancing is not possible when using back-boring insert holders. In this case, the highest unbalance reduction is obtained when both balancing rings are set on their largest graduation.

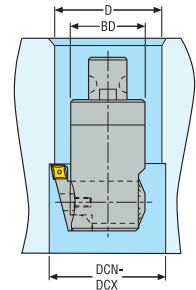
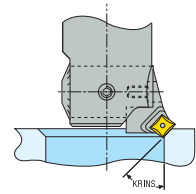

Insert holders, for fine boring heads EPB 620/ 780/ 790

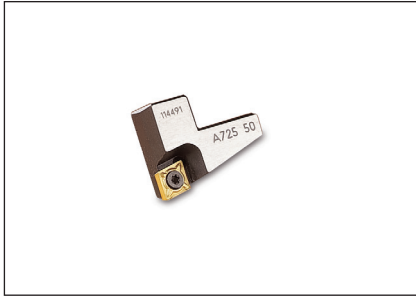

• Suitable for radial boring heads EPB 620/ 780/ 790

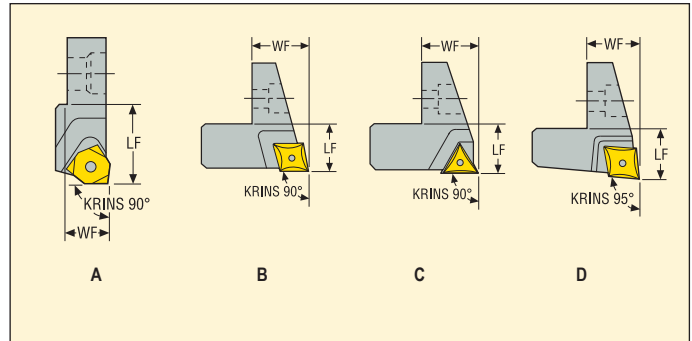

Insert holders type	For boring head	**	Insert holder size	Capacity DCN-DCX Ø mm	Ordering and Product No.	Designation	Dimensions in mm		Suitable insert size	Design	KG
							WF	LF			
90° for WB inserts	EPB 78008 / EPB 78009		09	15.0-23.5	00056634	A78209	4,0	7,2	WB...0301...	A	0,01
90° for CC inserts	EPB 78010		10	23.0-31.0	00056580	A72510	4,5	10,3	CC...0602...	B	0,01
	EPB 78020 / EPB 79020 / EPB 62020		20	30.0-40.0/34.0-46.0	00056581	A72520	5,0	8,3	CC...0602...	B	0,02
	EPB 78030 / EPB 79030 / EPB 62030		30	39.0-51.0/42.0-56.0	00056582	A72530	8,0	10,3	CC...0602...	B	0,02
	EPB 78040 / EPB 79040 / EPB 62040		40	50.0-65.0/52.0-69.0	00056583	A72540	9,5	10,3	CC...0602...	B	0,02
	EPB 78050 / EPB 79050 / EPB 62050		50	64.0-86.0	00056584	A72550	12,5	10,3	CC...0602...	B	0,02
	EPB 7806AL / EPB 62060		6A	85.0-115.0	02689978	A7256A	18,5	14,5	CC...09T3...	B	0,05
	EPB 78060 / EPB 79060 / EPB 731S500		60	85.0-115.0	00056585	A72560	18,9	16,5	CC...09T3...	B	0,08
	EPB 78060 / EPB 79060 / EPB 731S500	**	65	114.0-144.0	00056587	A72565	33,7	16,5	CC...09T3...	B	0,09
	EPB 78070		70	114.0-160.0	00056588	A72570	18,9	16,5	CC...09T3...	B	0,09
EPB 78070		75	159.0-205.0	00056589	A72575	41,7	16,5	CC...09T3...	B	0,12	
90° for TC inserts	EPB 78030 / EPB 79030 / EPB 62030		30	39.0-51.0/42.0-56.0	00056572	A72430	7,9	10,3	TC...1102...	C	0,01
	EPB 78040 / EPB 79040 / EPB 62040		40	50.0-65.0/52.0-69.0	00056573	A72440	9,4	10,3	TC...1102...	C	0,02
	EPB 78050 / EPB 79050 / EPB 62050		50	64.0-86.0	00056574	A72450	12,4	10,3	TC...1102...	C	0,02
	EPB 78060 / EPB 79060 / EPB 731S500		60	85.0-115.0	00056575	A72460	18,9	16,3	TC...1102...	C	0,08
	EPB 78060 / EPB 79060 / EPB 731S500	**	65	114.0-144.0	00056577	A72465	33,7	16,5	TC...1102...	C	0,09
	EPB 78070		70	114.0-160.0	00056578	A72470	18,9	16,3	TC...1102...	C	0,1
	EPB 78070		75	159.0-205.0	00056579	A72475	41,7	16,5	TC...1102...	C	0,13
95° for CC inserts	EPB 78010		10	23.0-31.0	00056590	A72610	4,5	10,3	CC...0602...	D	0,01
	EPB 78020 / EPB 79020 / EPB 62020		20	30.0-40.0/34.0-46.0	00056591	A72620	5,0	8,3	CC...0602...	D	0,01
	EPB 78030 / EPB 79030 / EPB 62030		30	39.0-51.0/42.0-56.0	00056592	A72630	8,0	10,3	CC...0602...	D	0,01
	EPB 78040 / EPB 79040 / EPB 62040		40	50.0-65.0/52.0-69.0	00056593	A72640	9,5	10,3	CC...0602...	D	0,02
	EPB 78050 / EPB 79050 / EPB 62050		50	64.0-86.0	00056594	A72650	12,5	10,3	CC...0602...	D	0,02
	EPB 78060 / EPB 79060 / A731S500		60	85.0-115.0	00056595	A72660	18,9	16,5	CC...09T3...	D	0,07
	EPB 78060 / EPB 79060 / EPB 731S500	**	65	114.0-144.0	00056597	A72665	33,7	16,5	CC...09T3...	D	0,09
	EPB 78070		70	114.0-160.0	00056598	A72670	18,9	16,5	CC...09T3...	D	0,09
	EPB 78070		75	159.0-205.0	00056599	A72675	41,7	16,5	CC...09T3...	D	0,12

Spare Parts

For insert size	Insert key	Insert screw
CC...0602...	T07P-3	C02504-T07P
CC...09T3...	T15P-3	C04008-T15P
TC...1102...	T07P-3	C02504-T07P
WB...0301...	T06P-2	C02035-T06P

Please check availability in current price and stock-list

**The precision balancing of EPB A790 heads is not possible when using the large insert holders. For spare insert screws and spare insert keys, see page(s) 479

Chamfering insert holders, for fine boring heads EPB 620/ 780/ 790



• Suitable for radial boring heads EPB 620/ 780/ 790

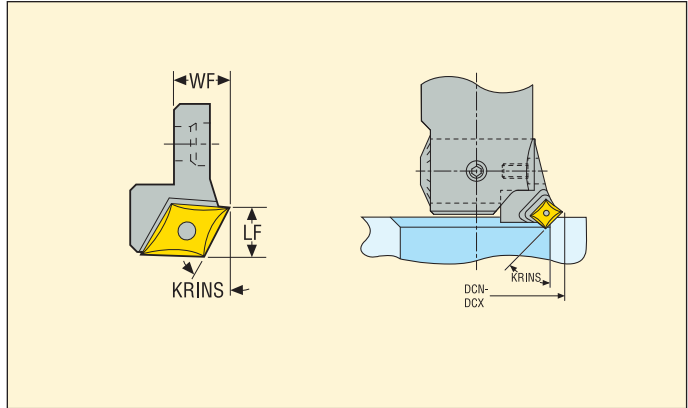

KRINS°	For boring head	Insert holder size	Capacity DCN-DCX Ø mm	Ordering and Product No.	Designation	Dimensions in mm		Suitable insert size	KG
						WF	LF		
30,0	EPB 78010	10	23,0-31,0	00086885	A72910CC0630	4,5	10,8	CC...0602...	0,01
	EPB 78020 / EPB 79020 / GL32-0620-20	20	30,0-40,0/34,0-36,0	00086888	A72920CC0630	4,9	10,0	CC...0602...	0,01
	EPB 78030 / EPB 79030 / EPB 62030	30	39,0-51,0/42,0-56,0	00086891	A72930CC0630	8,1	10,5	CC...0602...	0,01
	EPB 78040 / EPB 79040 / EPB 62040	40	50,0-65,0/52,0-69,0	00086894	A72940CC0630	9,5	10,5	CC...0602...	0,02
	EPB 78050 / EPB 79050	50	64,0-86,0	00086897	A72950CC0630	12,5	10,5	CC...0602...	0,02
	EPB 78060 / EPB 79060 / A731S500	60	85,0-115,0	00086900	A72960CC0930	19,1	16,5	CC...09T3...	0,08
	EPB 78070	70	114,0-160,0	00086903	A72970CC0930	18,8	16,4	CC...09T3...	0,09
45,0	EPB 78010	10	23,0-31,0	00086886	A72910CC0645	4,5	11,5	CC...0602...	0,01
	EPB 78020 / EPB 79020 / EPB 62020	20	30,0-40,0/34,0-46,0	00086889	A72920CC0645	5,0	10,0	CC...0602...	0,01
	EPB 78030 / EPB 79030 / EPB 62030	30	39,0-51,0/42,0-56,0	00086892	A72930CC0645	8,1	10,5	CC...0602...	0,01
	EPB 78040 / EPB 79040 / EPB 62040	40	50,0-65,0/52,0-69,0	00086895	A72940CC0645	9,5	10,5	CC...0602...	0,02
	EPB 78050 / EPB 79050	50	64,0-86,0	00086898	A72950CC0645	12,4	10,3	CC...0602...	0,02
	EPB 78060 / EPB 79060 / A731S500	60	85,0-115,0	00086901	A72960CC0945	19,1	16,5	CC...09T3...	0,07
	EPB 78070	70	114,0-160,0	00086904	A72970CC0945	18,8	16,4	CC...09T3...	0,09

Spare Parts

For insert size	Insert key	Insert screw
CC...0602...	T07P-3	C02504-T07P
CC...09T3...	T15P-3	C04008-T15P

Please check availability in current price and stock-list

For spare insert screws and spare insert keys, see page(s) 479

**For capacity DC with Bridge bars and Jumbo Bridge bars, see page 458

Fine back boring insert holders, for fine boring heads EPB 620/ 780/ 790

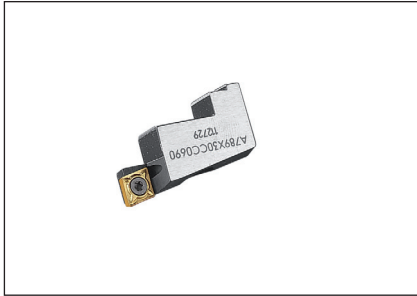

- Suitable for radial boring heads EPB 620/ 780/ 790
- *The precision balancing of EPB 790 heads is not possible when using back-boring insert holders

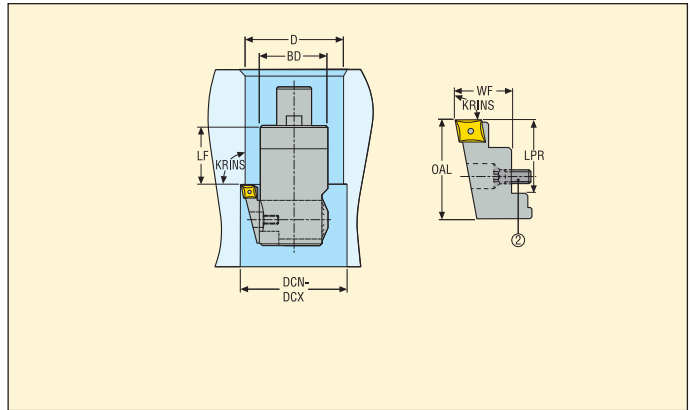

For head	Back-boring capacity DCN-DCX Ø mm	KRINS°	Ordering and Product No.	Designation	Dimensions in mm					Suitable insert size	
					LF	BD	OAL	LPR	WF		
A78010 // A78020 & A79020 // GL32-0620-20	39.5-47.5 // 46-56 // 49.7-61.7	90,0	00086907	A789X10CC0690	16.5 // 21.5 // 7.75	21.5 // 27 // 32	22,0	16,0	12,8	CC...0602...	0,01
A78030 & A79030 // A78040 & A79040 // A78050 & A79050 // GL40-0620-30 // GL50-0620-40	53-65 // 61-76 // 69-91 // 57.6-70.2 // 67.6-80.2	90,0	00086910	A789X30CC0690	32 // 39 // 49 // 1.75 // 2.75	35 // 43 // 54 // 40 // 50	30,0	23,0	15,0	CC...0602...	0,03
A78060 & A79060 // A731S500	89-119 // *	90,0	00086909	A789X60CC0690	50	70	50,0	38,5	21,0	CC...0602...	0,09
A78070	118-164	90,0	00086911	A789X70CC0690	60	95	50,0	38,5	21,0	CC...0602...	0,1

*For Back-boring capacity DC with Bridge bars and Jumbo Bridge bars, see page 462

Spare Parts**

For	Insert screw	Key
A789X10CC0690	C02504-T07P	T07P-3
A789X30CC0690	C02504-T07P	T07P-3
A789X60CC0690	C02504-T07P	T07P-3
A789X70CC0690	C02504-T07P	T07P-3

Please check availability in current price and stock-list

For spare insert screws and spare insert keys, see page(s) 479 *The fine back boring insert holders delivery content includes a specific insert holder clamp screw, to be used instead the standard clamp screw delivered with the boring heads.

Recommended machining conditions

For further application details refer to the operating instructions supplied with the boring heads and with the GL bars.

Maximum speeds for fine boring heads, radial type

The maximum speeds shown in boring heads Product pages are related to the boring head's mechanical design and balancing quality. Speeds inside these limits have to be chosen in regard to the other machining conditions, e.g. workpiece material, cutting edge (insert), tooling length, machine spindle.

By boring applications with Steadyline® bars, make sure not to overpass the max. RPM of the bars: See the Operating instructions supplied with the Steadyline® bars.

Below max. RPM are for boring heads equipped with boring insert holders or chamfering insert holders. When using back boring insert holders on holders on EPB 620, EPB 790 or EPB 780 heads type heads, use max. rpm for A780.. type, similar size.

Head	Capacity \varnothing mm	Max. RPM	Implied max cutting speed v_c at min. Cap.	Implied max cutting speed v_c at max. Cap.
EPB 620 Fine boring heads, with GL and BA machine side connection, for Steadyline® vibration damping turning and boring bars				
GL32-0620-20	34 - 46	7000	748	1012
GL32-0620-30	42 - 56	5600	739	985
GL32-0620-40	52 - 69	4800	784	1040
BA060-FB620-50	66 - 88	4000	830	1105
BA080-FB620-60	86 - 116	3000	810	1093
EPB 790 Fine boring heads, balanceable, with Graflex® connection				
A79020	30 - 40	16000	1508	2011
A79030	39 - 51	12250	1501	1963
A79040	50 - 65	10000	1571	2042
A79050	64 - 86	7500	1508	2026
A79060	85 - 115	5600	1495	2023
EPB 780 Fine boring heads, with Graflex® connection				
A78008	15 - 18,5	16000	754	930
A78009	18 - 23,5	13000	735	960
A78010	23 - 31	10000	723	974
A78020	30 - 40	8000	754	1005
A78030	39 - 51	6000	735	961
A78040	50 - 65	5000	785	1021
A78050	64 - 86	3700	744	1000
A78060	85 - 115	2700	721	975
	114 - 144	2200	788	995
A78070	114 - 160	2000	716	1005
	159 - 205	1600	799	1030
EPB 780 Fine boring heads with Seco-Capto™ connection				
C3-391.0780-30	39-51	6000	735	961
C4-391.0780-40	50-65	5000	785	1021
C5-391.0780-50	64-86	3700	744	1000
C6-391.0780-60	85-115	2700	721	975
	114-144	2200	788	995
C8-391.0780-70	114-160	2000	716	1005
	159-205	1600	799	1030

Note: The maximum speeds are related to the boring head's mechanical design and balancing quality. Speeds inside these limits have to be chosen in regard to the other machining conditions, e.g. workpiece material, cutting edge (insert), tooling length, machine spindle. At speeds from approx. 8000 RPM and above, the basic holders and the extensions/reducers should be fine balanced.

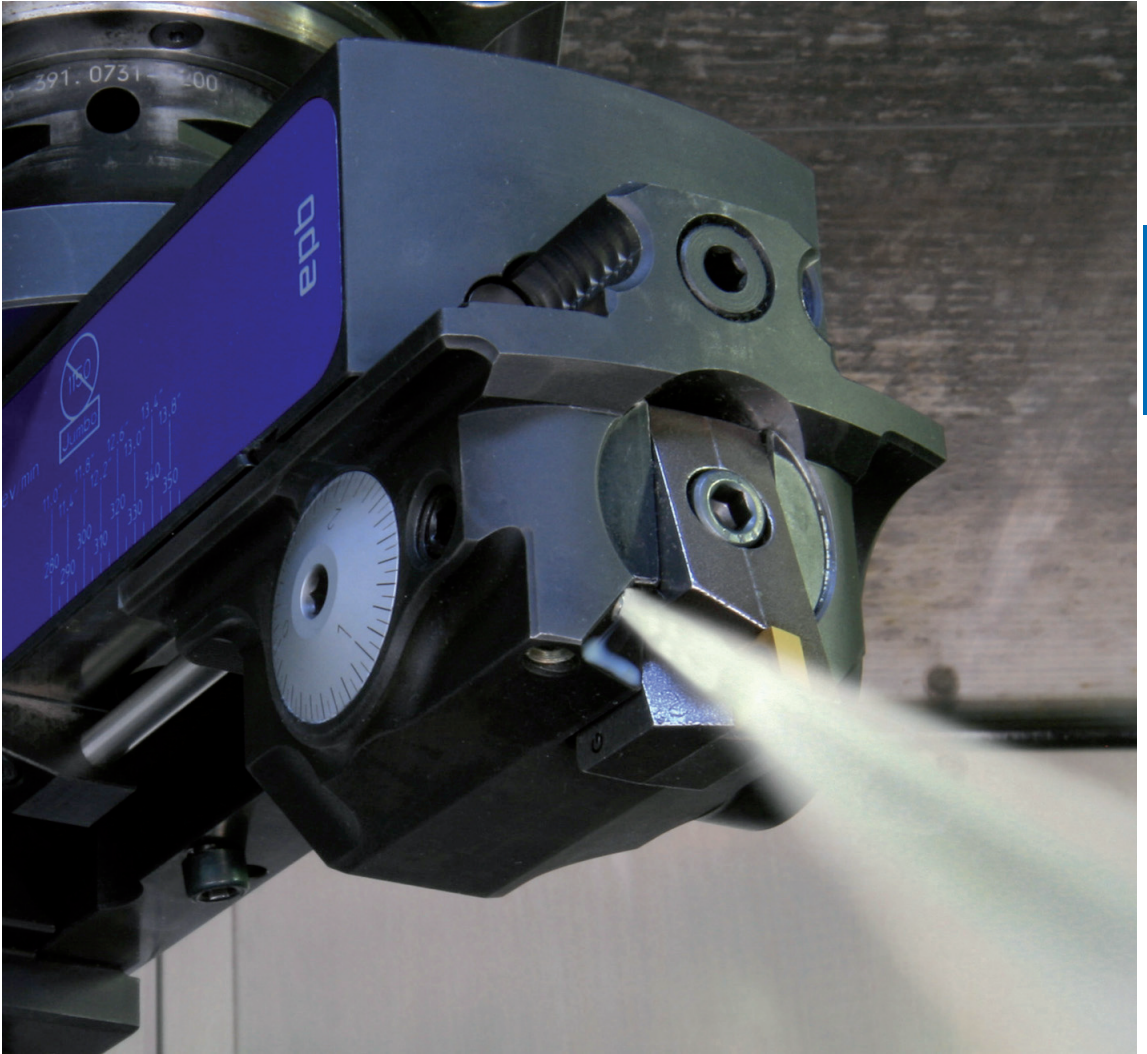

Overview

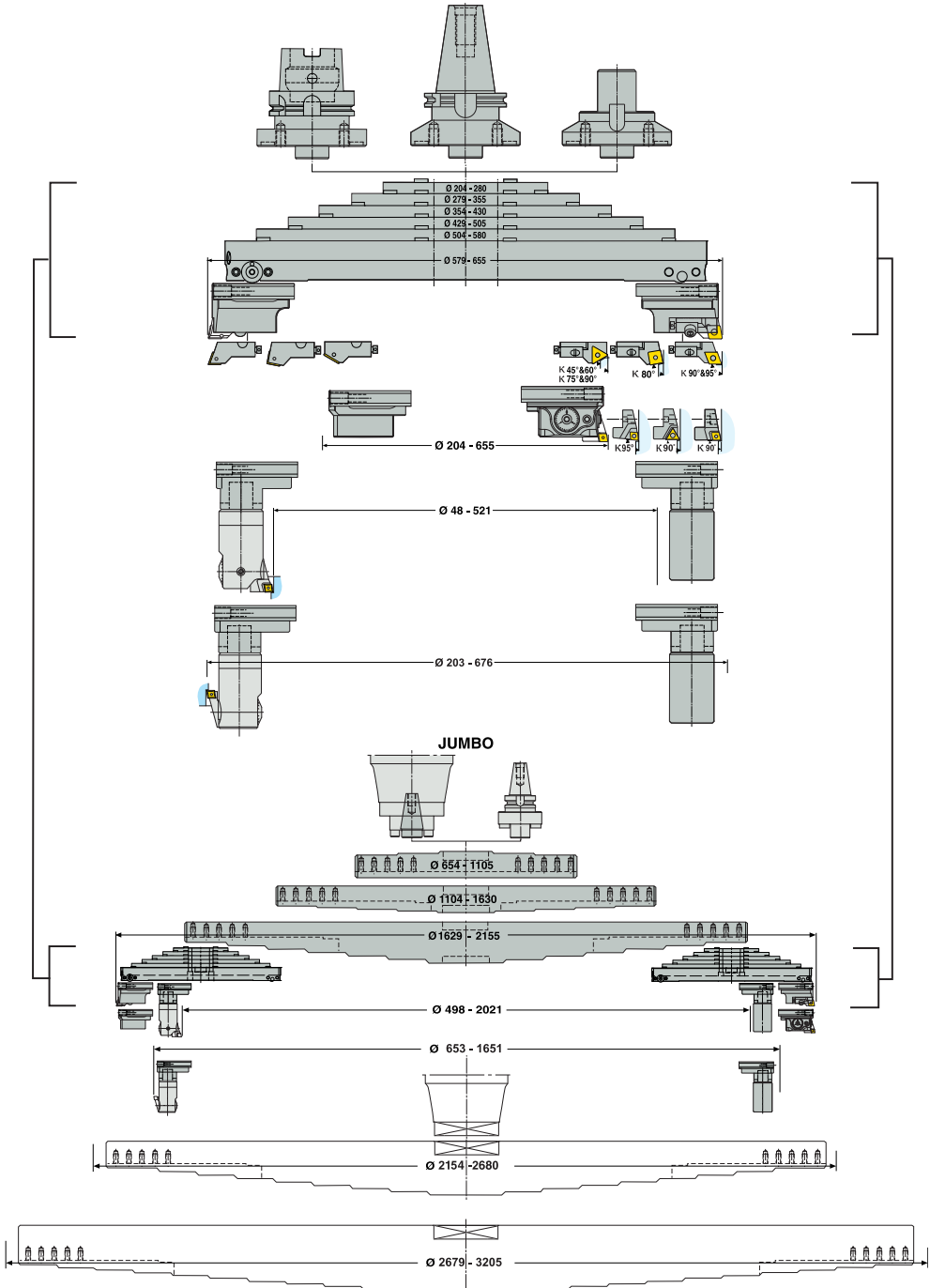

Features

5 Jumbo Bridge bars for boring \varnothing 654 to 3205 mm (also OD-overturning \varnothing 498 to 3071 mm and back-boring \varnothing 653 to 3226 mm).

Jumbo Bridge bars made of high tensile aluminium with spindle steel interfaces, are designed to hold two classic Bridge bars in several positions.

Sizes A731S001, 002, 003 are delivered with 4 locking screws to be fitted onto a milling cutter holder, flange mounting Type 569, spigot \varnothing 60 mm - or to be fitted directly onto the machine spindle (DIN 2079/50 workpiece side), using the centering spigot shown in accessories.

Jumbo Bridge bars are delivered with two lifting rings.

Sizes A731S004-...* and A731S005-...* are available on request, with standard or specific spindle fitting possibilities, according to the machine:

Capacity DCN-DCX \varnothing mm	Designation	Dimensions in mm (see drawing on Product page)							
		DCB	LF	HTB	LB	CBDP	WB	DCON	
2154-2680	A731S004-...*	*	70	300	160	*	2140	*	*
2679-3205	A731S005-...*	*	110	400	200	*	2665	*	*

* designation code and dimensions will be completed related to the spindle fitting type.

Main new features

The new Jumbo Bridge bars 'S' feature through coolant channels to feed the coolant from the holder or the flange mount towards the two standard Bridge bars, and have a complementary locking screw of the standard Bridge bars.

Note: These new Jumbo Bridge bars 'S' can hold all classic Bridge bars (the new 'S', or the previous ones): when using the previous ones, the complementary clamping screw cannot be used. Through coolant to the cutting edge is only possible when using 'S' Jumbo Bridge bars and 'S' standard Bridge bars.

In order to keep balance, do not mix new and previous standard Bridge Bars and blocks on the same Jumbo Bridge bar.

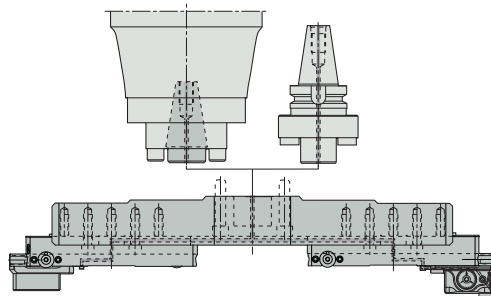

Features

6 Bridge bars for boring \varnothing 204 to 655 mm (also OD-overturning \varnothing 48 to 521 mm and back-boring)

Bridge bars have a machine side connection \varnothing 130 mm for direct fitting onto arbors for Bridge bars (SA and HSK) or onto the Graflex® adapter. When using the Graflex® adapter, extensions are possible as well as spindle flange clamping, see Graflex® modular system. Angular position of the Bridge bar every 30° onto the arbors or Graflex® adapter, for optimized magazine storage.

Bridge bars can hold rough, fine, counterweight or Graflex® boring blocks.

The boring blocks are locked onto the Bridge bar by means of two cylinders actuated by three clamping screws: One of the clamping screws has a stop disc, which limits the block's sliding stroke inside its setting capacity and stops the block from sliding out of the Bridge bar. Precise and step free block sliding for diameter adjustment (38 mm stroke on radius), using the block's adjusting screw which is linked to the retaining pin of the Bridge bar.

Coolant through the Bridge bars and the boring blocks, towards the cutting edges.

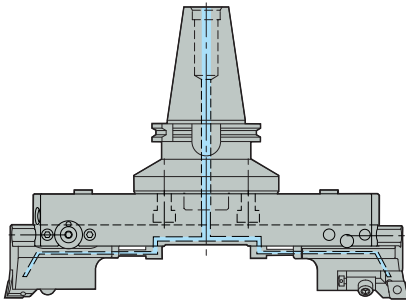

Max RPM, see page 468.

Note: These new Bridge bars (Part No. A731S 0_0) cannot hold previous types of boring blocks (Part No. A731 _00 -without S-).

For the Bridge bar and Jumbo Bridge bar selection, related to the boring, OD-overturning or back-boring diameter to be produced, see Bridge bar selection charts, pages 457-462.

Features

Rough boring block

A large twin rough boring head requires two rough boring blocks, each equipped with a cartridge. Rough boring block through coolant, towards the cutting edge.

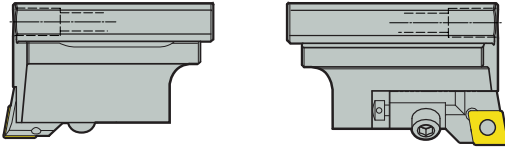

Cartridges

A large range of cartridges is available:

- Cartridges with 90° lead angle, recommended in most of the boring applications for a lower power consumption,
- Cartridges with 80° lead angle, recommended for through hole boring (and chamfering), particularly in cast iron to avoid exit failure.

The power consumption is higher.

- Other cartridges with ISO5611/h1 = 16 mm fitting interface are suitable.

Note: The two cartridges can be set on the same diameter (symmetrical boring) or in a staggered position (staggered boring).

A cartridge raising

corner shim is available as an accessory (Part No. 18LS0316).

Assembling and setting procedures, see Instructions pages.

Fine boring block and counterweight block

A large fine boring head requires one fine boring block equipped with an insert holder and one counterweight block.

Diameter setting mechanism of the fine boring block with a micrometric setting screw (1 increment = 5 µm on the diameter).

The setting system is protected and lubricated for life.

The precision of the mechanism guarantees repeatable accuracy.

The diameter adjusting screw is located on the side of the block to offer easy access.

Fine boring block through coolant, towards the cutting edge.

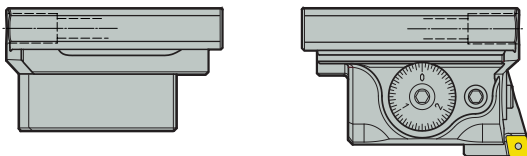

Suitable fine boring insert holders A72460, A72560 or A72660 have to be ordered separately: they are the same as on radial type fine boring heads, see page 447.

Assembling and setting procedures, see Instructions page.

Features

Graflex® boring blocks, for OD-overturning or back-boring

This block has a female Graflex® front connection size G5. Any Graflex® boring head, special tool or standard Graflex® module size G5 can be mounted onto the Bridge bars, e.g. the drawing showing set-ups for OD-overturning or back-boring using two Graflex® boring blocks fitted with a Graflex® fine boring head A78050 with insert holder (e.g. A72550 for OD-turning) a OD-turning insert holder (e.g. A789X30CC0690) and a Graflex® counterweight (e.g. Part No. BM050W78050).

Two positions of the Graflex® module are possible on the block, as it has 2x2 ball nose screw positions, and two tenon notches placed at 180°.

Block and boring head through coolant, towards the cutting edge.

Assembling and setting procedures, see Instructions pages.

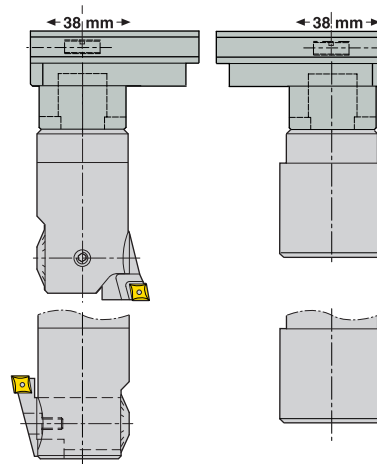

Note: These new boring blocks can also be fitted onto the previous type of Bridge bars

These new boring blocks (Part No. A731S 400, A731S 500, A731S 600, A731S 40128) can also be fitted onto the previous type of Bridge bars (Part No. A731 0_0 -without S-).

Assembling and max. RPM instructions of the previous type of Bridge bars being valid. In order to keep balance, do not mix new and previous blocks on the same Bridge bar.

Advice for 'through coolant' accessories selection

Roughing (Bridge bar with 2 rough boring blocks):

For directable coolant supply onto both cutting edges, use 2 coolant pipe connectors (Part No. AU731S00700), to be mounted onto the Bridge Bar, and 2 directable coolant supply nozzle sets (Part No. AU731S40700), to be mounted onto each rough boring block.

For normal through coolant from the block's channel, use 2 coolant pipe connectors (Part No. AU731S00700), to be mounted onto the Bridge Bar.

Fine boring (Bridge bar with 1 fine boring block & 1 counterweight):

Use 1 coolant pipe connector (Part No. AU731S00700), to be mounted onto the Bridge Bar in order to connect the fine boring block. As the fine boring block originally features a coolant supply nozzles, directable coolant supply is directly obtained.

OD-overturning (e.g. Bridge bar with 2 Graflex® boring blocks equipped with one fine boring head and one counterweight): Use 1 coolant pipe connector (Part No. AU731S00700), to be mounted onto the Bridge bar in order to connect the Graflex® boring block with fitted boring head. Graflex® boring block's central coolant channel will feed coolant into the fitted boring head.

Note: Allowable coolant pressure = 70 bars maximum.

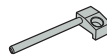
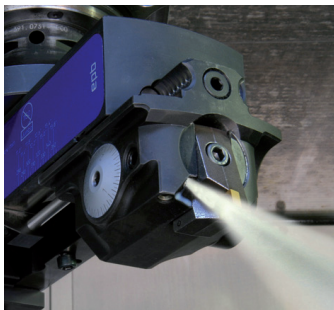

Coolant pipe connector
(Part No. AU731S00700)

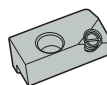

Directive coolant supply nozzle set
(Part No. AU731S40700)

Building Bridge bar boring assemblies:

A rough boring assembly up to \varnothing 655 mm requires: 1 Bridge bar (A731S 0_0) + 2 rough boring blocks (2x A731S 400) with 2 cartridges*.

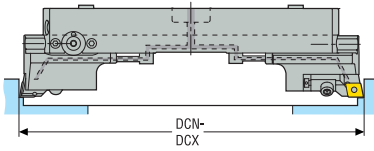

Fig.1

A fine boring assembly up to \varnothing 655 mm requires: 1 Bridge bar (A731S 0_0) + 1 fine boring block (A731S 500) with 1 fine boring insert holder size 60** + 1 counterweight block (A731S 600).

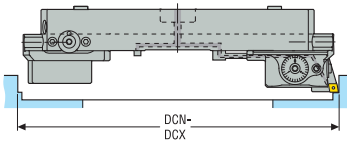

Fig. 2

A rough boring assembly up to \varnothing 3205 mm requires: 1 Jumbo Bridge bar (A731S 00_) + 2 Bridge bars (A731S 0_0) + 2 rough boring blocks (2x A731S 400) with 2 cartridges*.

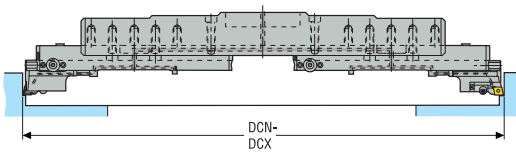

Fig. 3

A fine boring assembly up to \varnothing 3205 mm requires: 1 Jumbo Bridge bar (A731S 00_) + 2 Bridge bars (A731S 0_0) + 1 fine boring block (A731S 500) with 1 fine boring insert holder size 60** + 1 counterweight block (A731S 600).

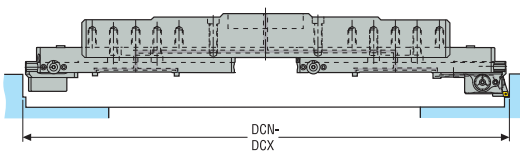

Fig. 4

* Cartridges to be ordered separately.

** Insert holders to be ordered separately.

Building Bridge bar boring assemblies: Bridge bar(s) selection chart to build a required BORING diameter

For boring DCN-DCX Ø (mm)	Jumbo Bridge bar	Classic Bridge bar(s)	For rough boring		For fine boring	
				Fig.		Fig.
204-280	–	A731S 010	2x A731S 400 + 2 cartridges	1	A731S 500 + 1 insert holder + A731S 600	2
279-355	–	A731S 020				
354-430	–	A731S 030				
429-505	–	A731S 040				
504-580	–	A731S 050				
579-655	–	A731S 060				
654-805	A731S 001	2x A731S 010	2x A731S 400 + 2 cartridges	3	A731S 500 + 1 insert holder + A731S 600	4
654-880		2x A731S 020				
804-955		2x A731S 030				
879-1030		2x A731S 040				
1029-1105		2x A731S 050				
1104-1255	A731S 002	2x A731S 010	2x A731S 400 + 2 cartridges	3	A731S 500 + 1 insert holder + A731S 600	4
1104-1330		2x A731S 020				
1179-1405		2x A731S 030				
1254-1480		2x A731S 040				
1329-1555		2x A731S 050				
1404-1630		2x A731S 060				
1629-1780	A731S 003	2x A731S 010	2x A731S 400 + 2 cartridges	3	A731S 500 + 1 insert holder + A731S 600	4
1629-1855		2x A731S 020				
1704-1930		2x A731S 030				
1779-2005		2x A731S 040				
1854-2080		2x A731S 050				
1929-2155		2x A731S 060				
2154-2305	A731S 004	2x A731S 010	2x A731S 400 + 2 cartridges	3	A731S 500 + 1 insert holder + A731S 600	4
2154-2380		2x A731S 020				
2229-2455		2x A731S 030				
2304-2530		2x A731S 040				
2379-2605		2x A731S 050				
2454-2680		2x A731S 060				
2679-2830	A731S 005	2x A731S 010	2x A731S 400 + 2 cartridges	3	A731S 500 + 1 insert holder + A731S 600	4
2679-2905		2x A731S 020				
2754-2980		2x A731S 030				
2829-3055		2x A731S 040				
2904-3130		2x A731S 050				
2979-3205		2x A731S 060				

Building Bridge bar OD-overturning assemblies:

A fine OD-overturning assembly up to \varnothing 521 mm requires: 1 Bridge bar (A731S 0_0) + 2 Graflex® blocks (2x A731S 40128) + e.g. 1 fine boring head (A780 50) with 1 fine boring insert holder size 60* + 1 counterweight (BM050W78050).

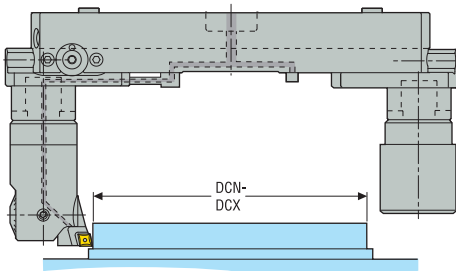

Fig.1

A fine OD-overturning assembly up to \varnothing 3071 mm requires: 1 Jumbo Bridge bar (A731S 00_) + 2 Bridge bars (A731S 0_0) + e.g. 1 fine boring head (A780 50) with 1 fine boring insert holder size 60* + 1 counterweight (BM050W78050).

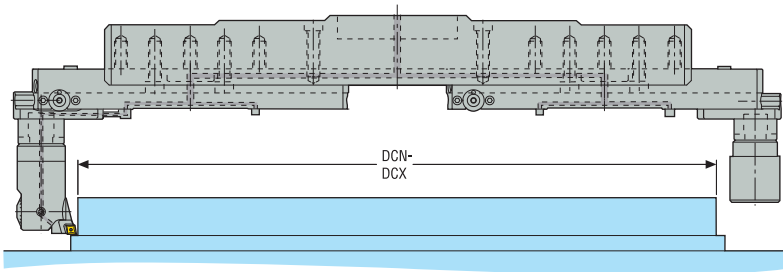

Fig. 2

* Insert holders to be ordered separately.

Building Bridge bar OD-overturning assemblies: Bridge bar(s) selection chart to build a required OD-overturning diameter

For OD-overturning DCN-DCX Ø (mm)	Jumbo Bridge bar	Classic Bridge bar(s)	For fine OD-overturning	Fig.
48-146	–	A731S 010	2x A731S 40128 + 1x A780 50 + 1 insert holder + 1x BM050W78050	1
123-221	–	A731S 020		
198-296	–	A731S 030		
273-371	–	A731S 040		
348-446	–	A731S 050		
423-521	–	A731S 060		
498-671	A731S 001	2x A731S 010	2x A731S 40128 + 1x A780 50 + 1 insert holder + 1x BM050W78050	2
498-746		2x A731S 020		
648-821		2x A731S 030		
723-896		2x A731S 040		
873-971		2x A731S 050		
948-1121	A731S 002	2x A731S 010	2x A731S 40128 + 1x A780 50 + 1 insert holder + 1x BM050W78050	2
948-1196		2x A731S 020		
1098-1271		2x A731S 030		
1173-1346		2x A731S 040		
1323-1421		2x A731S 050		
1398-1496		2x A731S 060		
1473-1646	A731S 003	2x A731S 010	2x A731S 40128 + 1x A780 50 + 1 insert holder + 1x BM050W78050	2
1473-1721		2x A731S 020		
1623-1796		2x A731S 030		
1698-1871		2x A731S 040		
1848-1946		2x A731S 050		
1923-2021		2x A731S 060		
1998-2171	A731S 004	2x A731S 010	2x A731S 40128 + 1x A780 50 + 1 insert holder + 1x BM050W78050	2
1998-2246		2x A731S 020		
2148-2321		2x A731S 030		
2223-2396		2x A731S 040		
2373-2471		2x A731S 050		
2448-2546		2x A731S 060		
2523-2696	A731S 005	2x A731S 010	2x A731S 40128 + 1x A780 50 + 1 insert holder + 1x BM050W78050	2
2523-2771		2x A731S 020		
2973-2846		2x A731S 030		
2748-2921		2x A731S 040		
2898-2996		2x A731S 050		
2973-3071		2x A731S 060		

Building Bridge bar back-boring assemblies:

A fine back-boring assembly up to \varnothing 676 mm requires: 1 Bridge bar (A731S 0_0) + 2 Graflex® blocks (2x A731S 40128) + e.g. 1 fine boring head (A780 50) with 1 back boring insert holder size 50° + 1 counterweight (BM050W78050).

Determination of minimum access diameter (D min)

Balancing condition: $WF1 = WF2$

$$D_{min} = DC + 5 \cdot BCDP$$

BCDP = distance between insert's cutting edge and fitted boring head's A78050 body ($7,5 < BCDP < 18,5$).

The two extreme cases:

- Boring head A78050 set to capacity mini:
 $D_{min} = DCN - 2,5$
- Boring head A78050 set to capacity maxi:
 $D_{min} = DCX - 13,5$

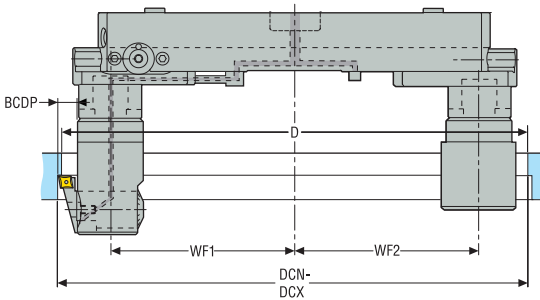

Fig.1

A fine back-boring assembly up to \varnothing 3226 mm requires: 1 Jumbo Bridge bar (A731S 00_) + 2 Bridge bars (A731S 0_0) + e.g. 1 fine boring head (A780 50) with 1 back boring insert holder size 50° + 1 counterweight (BM050W78050).

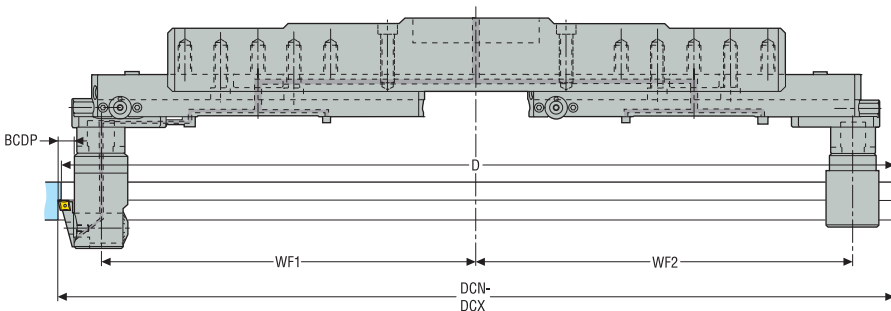

Fig. 2

* Insert holders to be ordered separately.

Building Bridge bar back-boring assemblies: Bridge bar(s) selection chart to build a required BACK-BORING diameter

For back boring DCN-DCX Ø (mm)	Jumbo Bridge bar	Classic Bridge bar(s)	For fine back-boring	Fig.
203-301	–	A731S 010	2x A731S 40128 + 1x A780 50 + 1 back boring insert holder + 1x BM050W78050	1
278-376	–	A731S 020		
353-451	–	A731S 030		
428-526	–	A731S 040		
503-601	–	A731S 050		
578-676	–	A731S 060		
653-826	A731S 001	2x A731S 010	2x A731S 40128 + 1x A780 50 + 1 back boring insert holder + 1x BM050W78050	2
653-901		2x A731S 020		
803-976		2x A731S 030		
878-1051		2x A731S 040		
1028-1126		2x A731S 050		
1103-1276	A731S 002	2x A731S 010	2x A731S 40128 + 1x A780 50 + 1 back boring insert holder + 1x BM050W78050	2
1103-1351		2x A731S 020		
1253-1426		2x A731S 030		
1328-1501		2x A731S 040		
1478-1576		2x A731S 050		
1553-1651		2x A731S 060		
1628-1801	A731S 003	2x A731S 010	2x A731S 40128 + 1x A780 50 + 1 back boring insert holder + 1x BM050W78050	2
1628-1876		2x A731S 020		
1778-1951		2x A731S 030		
1853-2026		2x A731S 040		
2003-2101		2x A731S 050		
2078-2176		2x A731S 060		
2153-2326	A731S 004	2x A731S 010	2x A731S 40128 + 1x A780 50 + 1 back boring insert holder + 1x BM050W78050	2
2153-2401		2x A731S 020		
2303-2476		2x A731S 030		
2378-2551		2x A731S 040		
2528-2626		2x A731S 050		
2603-2701		2x A731S 060		
2678-2851	A731S 005	2x A731S 010	2x A731S 40128 + 1x A780 50 + 1 back boring insert holder + 1x BM050W78050	2
2678-2926		2x A731S 020		
2828-3001		2x A731S 030		
2903-3076		2x A731S 040		
3053-3151		2x A731S 050		
3128-3226		2x A731S 060		

Recommended machining conditions

Best performances are obtained with through coolant (higher machining data, better surface finish, better chip evacuation).

Rough boring depends on the priorities: higher feed or larger chip removal use symmetrical setting of the cartridges (most common method, double feed compared to staggered setting), or staggered setting (double depth of cut).

In fine boring in steel, with good conditions, we recommend to use Cermet inserts, for high speeds and long life.

For detailed user instructions, please refer to the operating instructions supplied as part of the delivery content of the boring heads and with the Steadyliner® bars. These operating instructions can also be downloaded from www.secotools.com.

Troubleshooting

Please refer to troubleshooting advice, in rough boring chapter page 401, or fine boring chapter page 436.

Maximum speeds for Bridge bars

Due to the large sizes of Bridge bar boring heads, unsuitable RPM programming could cause unpredictable damage.

Below max. RPM are for present Bridge bar boring assemblies using present Bridge bar types (Part No. A731S 0_0) rough boring, fine boring and counterweight boring blocks (Part No. A731S_00) and Jumbo Bridge bar (Part No. A731 00_). For other assemblies, please contact your local Seco representative.

Note: when using present boring blocks (Part No. A731S 400, A731S 500, A731S 600, A731S 40128) onto previous type Bridge bars (Part No. A731 0_0 -without S-), the max RPM to consider are the ones recommended for the previous type Bridge Bars. To maintain balance, do not mix new and previous blocks on the same Bridge bar.

Head based on	Capacity DCN-DCX Ø mm (mm)	Max. RPM (RPM)	Implied max cutting speed v_c at min. Cap. (m/min)	Implied max cutting speed v_c at max. Cap. (m/min)
Bridge bar boring heads (with two boring blocks set symmetrically)				
A731S010	204 - 280	1600	1025	1407
A731S020	279 - 355	1150	1007	1282
A731S030	354 - 430	900	1000	1215
A731S040	429 - 505	750	1010	1189
A731S050	504 - 580	650	1029	1184
A731S060	579 - 655	550	1000	1131
Jumbo bridge bars (with two identical Bridge bars and boring blocks set symmetrically)				
A731S 001	654-1105	170	349	590
A731S 002	1104-1630	100	346	512
A731S 003	1629-2155	70	358	473
A731S 004	2154-2680	50	338	420
A731S 005	2679-3205	40	336	402

Note: The maximum speeds are related to the boring head's mechanical design and balancing quality. Speeds inside these limits have to be chosen in regard to the other machining conditions, e.g. workpiece material, cutting edge (insert), tooling length, machine spindle.

Custom made boring solutions

Seco-EPB has a strong experience in the design of custom made solutions for boring operations:

- Steadyline® vibration damping rough and fine boring solutions,
- Multi-edge boring bars,
- Special extensions with guiding pads, for long overhang operations,
- Combined bars for drilling, boring, chamfering, reaming, threading operations...

Please contact your local Seco representatives for more information.

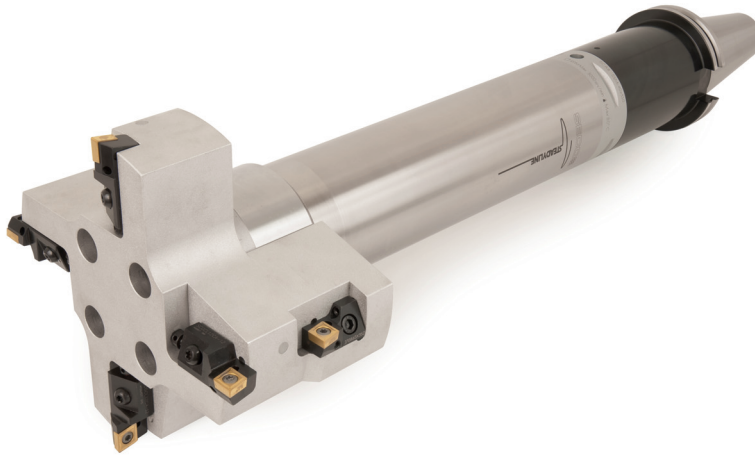

A selection of inserts for boring

This is a selection of inserts from the total Seco range, which are particularly suitable for boring. The selected insert sizes are those suitable for the range of boring heads.

Inserts for rough boring have high toughness to guarantee high metal removal and positive geometries to minimise spindle torque requirement. Inserts for fine boring have positive geometries and sharp edge wear resistant grades for accurate control of the bore tolerance, geometry and surface finish.

Code key, examples

CCMT120408 - F2 TP3501

Size (ISO designation)

Seco geometry

Seco grade

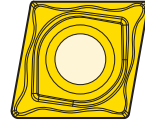

CCGT09T304 - 03 G3

Size (ISO designation)

EPB grade

EPB geometry



Insert grades for boring – ISO workpiece material classification

		P					M				K				N				S				H			
		P01 P10 P20 P30 P40 P50	M01 M10 M20 M30 M40	K01 K10 K20 K30 K40	N01 N10 N20 N30	S01 S10 S20 S30	H01 H10 H20 H30																			
CVD	TP1501	○					○				○								○							
	TP2501	○					○				○								○							
	TP3501	○					○				○								○							
	TP200	○					○				○								○							
	TP40	○					○				○								○							
	TM4000	○					○				○								○							
	TK1501	○					○				○								○							
	TK0501	○					○				○								○							
	TH1500	○					○				○								○							
	25	○					○				○								○							
PVD	TS2000	○					○				○								○							
	TH1000	○					○				○								○							
	CP500	○					○				○								○							
	26	○					○				○								○							
Uncoated	KX	○					○				○								○							
	HX	○					○				○								○							
	03	○					○				○								○							
Cermet	TP1020	○					○				○								○							
	TP1030	○					○				○								○							
	51	○					○				○								○							
PCBN	CBN10	○					○				○								○							
	CBN010	○					○				○								○							
	CBN200	○					○				○								○							
	81	○					○				○								○							
PCD	CBN060K	○					○				○								○							
	PCD20	○					○				○								○							
	91	○					○				○								○							

CVD coated grades recommended for boring

	TP1501	<p>Duratonic® technology coated grade. Highly heat and wear resistant grade extremely well suited for productive general turning of steels and a useful backup in other material groups.</p> <p>Ti(C,N) + Al₂O₃ + ...</p>
	TP2501	<p>Duratonic® technology coated grade. Designed with high wear resistance and edge strength applicable in a wide range of turning applications in steels as well as many stainless steels and cast irons.</p> <p>Ti(C,N) + Al₂O₃ + ...</p>
	TP3501	<p>TP3501 is intended for boring operations where the primary demand is toughness and reliability in machining steels and stainless steels.</p> <p>Ti(C,N) + Al₂O₃ DURATOMIC®</p>
	TP200	<p>TP200 is a universal grade with high versatility. The grade is intended for a wide range of turning applications in both steel and stainless steel and is also a good choice for cast iron.</p> <p>Ti(C,N) + Al₂O₃ + TiN</p>
	TP40	<p>TP40 is the basic grade for turning in the P40 range. Very tough grade for demanding operations on steel castings and forging, and on all types of stainless steel.</p> <p>TiC/Ti(C,N) + TiN</p>
	TK0501	<p>Duratonic® technology coated grade. A extremely wear resistant optimized grade choice for machining of grey cast iron and easier ductile cast irons.</p> <p>Ti(C,N) + Al₂O₃ + Used Edge Detection (Chrome)</p>
	TK1501	<p>Duratonic® technology coated grade. A highly wear resistant grade for cast irons in general as well as in steels. The grade is particularly capable in machining of ductile (nodular) cast irons also in more demanding setups and interrupted cuts.</p> <p>Ti(C,N) + Al₂O₃ + Used Edge Detection (Chrome)</p>
	TM4000	<p>TM4000 is intended for machining of stainless steel. The wear resistance together with the superior edge toughness make the grade the first choice in stainless steel applications.</p> <p>Ti(C,N) + Al₂O₃ DURATOMIC®</p>
	TH1500	<p>DURATOMIC® technology coated grade. An extremely hard super micrograin grade intended for machining of partly hardened steels and provide an alternative for cast iron finishing.</p> <p>Ti(C,N) + Al₂O₃</p>
	25 (EPB)	<p>Universal grade.</p> <p>The grade is intended for a wide range of boring applications in steel, stainless steel and cast iron.</p> <p>Good combination of wear resistance and toughness.</p> <p>Ti (C, N) + Al₂O₃.</p>

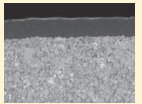

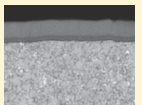
PVD coated grades recommended for boring

	TS2000	Hard micrograin principally intended for finishing operations in superalloys and titanium alloys. Also performs well in finishing operations on stainless steel. (Ti,Al)N + TiN
	CP500 & 26 (EPB)	A very tough micrograin intended for finishing and medium roughing of stainless steel. Can handle intermittent cutting operations very well. CP500 is also an alternative for aluminium alloys. (Ti,Al)N + TiN
	TH1000	Very hard supermicrograin grade intended for partly hardened steel components as well as generally workpiece materials such as superalloys and due to remarkable edge toughness it also provides high performance in interrupted cuts and hard-surface removal.

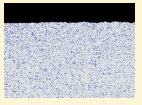
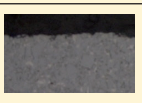
Uncoated grades recommended for boring

	KX & 03 (EPB)	Micrograin intended for machining aluminum and other non-ferrous materials.
	HX	Universal uncoated grade intended for machining of cast iron and hardened steels useful also in non-ferrous materials.

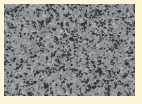
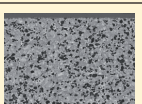
Cermet recommended for boring

	TP1020	Cermet with very high wear resistance intended for highest surface finish requirements with predictability and control in steel and stainless steel.
	TP1030	PVD-coated Cermet with very high wear resistance intended for high surface finish and productivity requirements with predictability in steel and stainless steel mainly. Ti-Al-Si-N nanolaminate coating.
	51 (EPB)	Cermet with very high wear resistance. Intended for finishing operations on steels, in which strict demands are made on surface finish.

CBN and PCD grades recommended for boring

	CBN010	<p>Format: Solid, full-face brazed layer and brazed tips (single and double sided).</p> <p>Composition: 50% CBN content grade with an average grain size of 2 μm and a TiC ceramic binder.</p> <p>Coating: No coating.</p>
	CBN10 & 81 (EPB)	<p>CBN, Cubic boron nitride grade, for light continuous to moderate interrupted cuts. Intended for fine boring in hardened steel and in superalloys.</p>
	CBN060K	<p>Solid, brazed tips (single and double sided) or sintered layer First choice for continuous to moderate interrupted cuts in hardened steel ($a_p < 0,5 \text{ mm}$). New (Ti,Si,Al)N PVD coating developed for high speed machining. New unique superalloy binder.</p>
	CBN200	<p>CBN, Cubic boron nitride grade, for finishing of pearlitic cast iron, and sintered iron.</p>
	PCD20 & 91 (EPB)	<p>PCD, polycrystalline diamond, for boring in aluminium and Al-alloys, copper, brass, bronze and synthetic materials.</p>

Inserts, recommended for rough boring, with cutting data

Designation	Uncoated Ground flank and pressed chipbreaker			Coated Pressed chipbreaker							Coated Ground flank direct chipbreaker, left hand cutting	Max depth of cut a_p (mm)	Feed per tooth Fz (mm/tooth)	
	KX	HX	03D3	TP2501	TP3501	TP40	TM4000	25C4	TP200	TK1501	CP500			
CPGT050204			02434654					02434652					2	0,08-0,2
CCMT060204-F1				02960857	03095430	00008505	02566087		74066010	03062942	00096854		2	0,1-0,22
CCMT060204-F2		74011732				74018652	02566088		74068123				2	0,1-0,22
CCGT060204L-UX											02497631		2	0,1-0,22
CCGT060204F-AL	00015710												2	0,1-0,22
CCMT060204-M3				02960858	03095431					03062944			2	0,1-0,22
CCMT09T308-F1				02960861	03095443	00008518	02566095		74065997	03063857	00096858		2,5	0,1-0,3
CCMT09T308-MF2				02956309	03095446		02754823				02754822		2,5	0,1-0,3
CCGT09T308L-UX											02497640		2,5	0,1-0,3
CCGT09T308F-AL	00015754												2,5	0,1-0,3
CCMT120408-F1				02960854	03095449					03062626			4	0,15-0,4
CCMT120408-MF2				02956311	03095452								4	0,15-0,4
CCGT120408L-UX											02610062		4	0,15-0,4
CCGT120408F-AL	00015790												5	0,15-0,4
SCMT060204-M3				02960423	03096621								2,5	0,1-0,22
SCMT09T308-F1				02960396	03096625				74069789	03062629	00099708		2,5	0,1-0,3
SCMT09T308-MF2				02956318	03096627						02755042		2,5	0,1-0,3
SCMT120408-F1				02960397	03096630						00099804		4	0,15-0,4
SCMT120408-M3				02960429	03096631					03063990			4	0,15-0,4
TCMT16T308-F1				02960408	03096643	74004572	02566147		74066002		00091357		5	0,15-0,4
TCMT16T308-MF2				02956323	03096645						02755046		5	0,15-0,4
TCGT16T308F-AL	00015875												4	0,15-0,4
CCMT160508-F2							02566098		00018067				7	0,2-0,5
CCMT160512-F2							02566099		00018082				7	0,2-0,5
SCMT150512-F2						74007348							7	0,2-0,5
TCMT220408-F2									74068150				7	0,2-0,5

For recommended cutting speeds, see pages 477-478.

Please check availability in current price and stock-list.

CPGT 	CCMT-F1 	CCMT-F2 	CCMT-M3 	CCMT-MF2 	CCGT-UX
CCGT-AL 	SCMT-M3 	SCMT-F1 	SCMT-MF2 	SCMT-F2 	TCMT-F1
TCMT-F2 	TCGT-AL 	TCMT-MF2 			

CN.. inserts, recommended for rough boring (double sided), with cutting data

Designation	Coated Pressed chipbreaker				Max depth of cut a_p (mm)	Feed f (mm/rev)
	TP3501	TP40	TM4000	TP200		
CNMG120408-M3	03093856			74037351	4,5	0,25-0,35
CNMG120408-MF3	03094138	74030598	02839059	00024328	4,5	0,25-0,35
CNMG120408-MF4	03094139		02566104		4,5	0,25-0,35
CNMG120408-MF5					4,5	0,25-.035
CNMG120408-MF1			02566103		4,5	0,25-0,35
CNMG120408-MR7	03094140	74017309	02593726		4,5	0,25-0,35

For recommended cutting speeds, see pages 477-478.

Please check availability in current price and stock-list

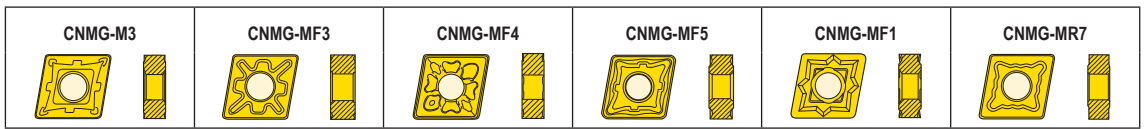

WARNING:

When using CN.. inserts it is important to use the recommended inserts and cutting data. Using other inserts and incorrect cutting data could result in high cutting stresses and machine/workpiece damage.

Inserts, recommended for fine boring, with cutting data

Designation	Coated						Cermet			CBN				PCD		Depth of cut a_p (mm)	Feed f (mm/rev)	
	TP1501	TS2000	TK1501	CP500	26G6	TH1000	TH1500	51G1	TP1020	TP1030	CBN010	CBN060K	CBN200	81B1	PCD20			91J3
CCGT0602005-F1				02430287													0.01-0.3	0.03-0.15
CCGT060201-F1				02430307													0.01-0.3	0.03-0.15
CCGT060204L-UX				02497631													0.01-0.3	0.03-0.15
CCMT060202-F1	02960383	02614299		00096853				02754786	02754435								0.01-0.3	0.03-0.15
CCMT060204-F1	02960856	02615873	03062942	00096854		02825858	02825859	02754791	02754792								0.01-0.3	0.03-0.15
CCMW060202F-L1															00089760		0.01-0.3	0.03-0.15
CCMW060204F-L1															00005684		0.01-0.3	0.03-0.15
CCGW060202S-01020-LF												02464698					0.01-0.3	0.03-0.15
CCGW060204S-01020-LF										02916281		02464699					0.01-0.3	0.03-0.15
CCGW060204E-L1-B										02843086	02776337	02649599					0.01-0.3	0.03-0.15
CCGT09T301-F1				02430311													0.01-0.3	0.03-0.15
CCGT09T304L-UX				02497640													0.01-0.3	0.03-0.15
CCMT09T302-F1	02960837			00096856				02754805	02754806								0.01-0.3	0.03-0.15
CCMT09T304-F1	02960844	02615874	03063856	00096857		02731806	02731808	02754811	02754812								0.01-0.3	0.03-0.15
CCMT09T308-F1	02960853	02615876	03063857	00096858		02731807	02731809		02754821								0.01-0.3	0.03-0.15
CCMW09T304F-L1															00005686		0.01-0.3	0.03-0.15
CCMW09T308F-L1															00095357		0.01-0.3	0.03-0.15
CCGW09T304E-L1-B										02843126	02776338	02649607					0.01-0.3	0.03-0.15
CCGW09T308E-L1-B										02937148		02649608					0.01-0.3	0.03-0.15
CCGW09T304S-01020-LF										02916282		02464702					0.01-0.3	0.03-0.15
CCGW09T308S-01020-LF												02464703					0.01-0.3	0.03-0.15
TCGT110201-F1				02430376													0.01-0.3	0.03-0.15
TCMT110202-F1				02430419													0.01-0.3	0.03-0.15
TCMT110204-F1	02960401			02430421													0.01-0.3	0.03-0.15
TCMT110208-F1	02960403			00098986													0.01-0.3	0.03-0.15
TCGW110204E-L1-C										02848657	02776346						0.01-0.3	0.03-0.15
TCGW110208E-L1-C										02848792							0.01-0.3	0.03-0.15
TCGW110204S-01020-LF												02464742					0.01-0.3	0.03-0.15
TCGW110208S-01020-LF												02464744					0.01-0.3	0.03-0.15
TCMW110204F-L1															00005689		0.01-0.3	0.03-0.15

For recommended cutting speeds, see pages 477-478.
Please check availability in current price and stock-list

CCGT 	CCGT-UX 	CCMT-F1/CCGT-F1 	CCMW/CCGW-L1-B 	CCGW-LF
TCGT 	TCGT-F1 	TCGW-L1-C 	TCGW-LF 	TCMW/TCGW-L1-C
TCMT-F1 	WBG 	WBGW 		

Recommended cutting speeds for boring (related to workpiece material and insert grade)

SMG	v _c											
	KX & HX	03	TP40	TM4000	TP1501	TP2501	TP3501	TK0501	TK1501	TH1000	TH1500	CP500
P1			60-180		60-350	60-250	60-230					80-200
P2			60-180		60-350	60-250	60-230					80-200
P3			60-180		60-350	60-250	60-230					80-200
P4			60-180		60-350	60-250	60-230					80-200
P5			60-150		60-300	60-250	60-230					80-200
P6			60-140		60-300	60-230	60-200					80-180
P7			60-140		60-300	60-230	60-200					80-160
P8			60-120		60-250	60-230	60-200					80-130
P11			60-120		60-300	60-250	60-200					80-180
M1			60-130	60-180	100-200	60-200	60-200					60-160
M2			60-130	60-180	100-200	60-200	60-200					60-160
M3			60-120	60-170	100-180	60-200	60-200					60-150
M4			60-110	60-160	100-180	60-190	60-190					60-150
M5			60-110	60-150	100-180	60-180	60-180					60-150
K1			60-140		100-250		60-180	60-230	60-230			60-160
K2			60-140		100-250		60-180	60-230	60-230			60-160
K3			60-140		100-250		60-180	60-230	60-230			60-160
K4			60-140		100-250		60-180	60-200	60-200			60-160
K5			60-140		100-250		60-180	60-200	60-200			60-160
K6			60-130		100-250		60-180	60-200	60-200			60-160
K7			60-130		100-250		60-180	60-200	60-200			60-160
N1	150-800	150-800										150-800
N2	150-800	150-800										150-800
N3	150-500	150-500										150-500
N11	150-400	150-400										150-400
S1	20-50	20-50										20-50
S2	20-50	20-50										20-50
S3	20-50	20-50										20-50
S11	20-50	20-50										20-50
S12	20-50	20-50										20-50
S13	20-50	20-50										20-50
H3										50-150	50-150	
H5										50-140	50-140	
H7										50-150	50-150	
H8										30-130	30-130	
H11										30-120	30-120	
H12										30-120	30-120	
H21												
H31												

SMG = Seco material group

v_c = m/min

All cutting data are start values

Recommended cutting speeds for boring (related to workpiece material and insert grade)

SMG	v _c												
	26	25	TS2000	TP1020	TP1030	51	CBN10/ CBN010	81	CBN200	82	PCD20	91	Axiabore
P1	80-200	60-180		100-350	100-350	100-350							80-250
P2	80-200	60-180		100-350	100-350	100-350							80-250
P3	80-200	60-180		100-350	100-350	100-350							80-250
P4	80-200	60-180		100-350	100-350	100-350							80-250
P5	80-200	60-180		100-350	100-350	100-350							70-230
P6	80-180	60-160		100-300	100-300	100-300							70-230
P7	80-160	60-160		100-250	100-250	100-250							70-230
P8	80-130	60-130		100-250	100-250	100-250							70-200
P11	80-180	60-150		100-300	100-300	100-300							70-200
M1	60-160	60-140	60-200	80-200	80-200	80-200							60-200
M2	60-160	60-140	60-200	80-200	80-200	80-200							60-200
M3	60-150	60-130	60-200	80-200	80-200	80-200							60-180
M4	60-150	60-120	60-180	80-180	80-180	80-180							60-170
M5	60-150	60-120	60-180	80-180	80-180	80-180							60-170
K1	60-160	60-160		100-250	100-250	100-250			300-1000	300-1000			60-150
K2	60-160	60-160		100-250	100-250	100-250			300-1000	300-1000			60-150
K3	60-160	60-160		100-250	100-250	100-250			300-1000	300-1000			60-150
K4	60-160	60-160		100-250	100-250	100-250			300-1000	300-1000			60-130
K5	60-160	60-160		100-250	100-250	100-250							50-100
K6	60-160	60-160		100-180	100-180	100-180							50-100
K7	60-160	60-160		100-180	100-180	100-180							50-100
N1	150-800										300-1500	300-1500	200-800
N2	150-800										300-1500	300-1500	200-800
N3	150-500										200-800	200-800	200-800
N11	150-400										180-800	180-800	200-800
S1	20-50		20-80										20-60
S2	20-50		20-80										20-60
S3	20-50		20-80										60-50
S11	20-50		20-80										20-50
S12	20-50		20-80										20-50
S13	20-50		20-80										20-50
H3							80-180	80-180					
H5							80-200	80-200					
H7							80-150	80-150					
H8							80-150	80-150					
H11													
H12													
H21													
H31													

SMG = Seco material group

v_c = m/min

All cutting data are start values

Insert locking keys and screws of all boring insert holders, tools and cartridges

Specific clamp spare parts for CN.. inserts are shown in the CN.. type insert holders product page. Insert clamp spare parts for insert holders EPB 610 are shown in the insert holders for heads EPB 610 page 408.

Reminder: Spare parts are part of the original delivery content of insert holders, tools or cartridges.

Accessories are not included in the delivery content, to be ordered separately.

		Accessories		Spare Parts	
		Torx driver for insert locking screw*		Insert locking screw	
For rough boring insert holders	For insert size	Designation	Torx Plus	Designation	Torx Plus
	CP...0502	T07P-3	07	C02245-T07P	07
	CC...0602	T07P-3	07	C02504-T07P	07
	CC...09T3	T15P-3	15	C04008-T15P	15
	CC...1204	T15P-3	15	C05012-T15P	15
	CC...1605	T15P-3	15	C05012-T15P	15
	SC...0502	T07P-3	07	C02245-T07P	07
	SC...0602	T07P-3	07	C02504-T07P	07
	SC...09T3	T15P-3	15	C04008-T15P	15
	SC...1204	T15P-3	15	C05012-T15P	15
SC...1505	T15P-3	15	C05012-T15P	15	

* One Torx driver is delivered with each rough boring head.

		Accessories		Spare Parts	
		Torx driver for insert locking screw*		Insert locking screw	
For Axiabore™ type tool	For insert size	Designation	Torx Plus	Designation	Torx Plus
	WB...0301...	T06P-3	06	C02035-T06P	06
	CC...0602...	T07P-3	07	C02504-T07P	07
	-	T15P-3	15	C04008-T15P	15

Spare parts for insert holders

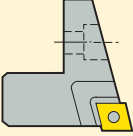
		Spare Parts			
		Insert key		Insert screw	
For fine boring insert holders, chamfering insert holders and back boring insert holders	For insert size		Torx Plus		Torx Plus
	WB...0301...	T06P-2	06	C02035-T06P	06
	CC...0602...	T07P-3	07	C02504-T07P	07
	CC...09T3...	T15P-3	15	C04008-T15P	15
	TC...1102...	T07P-3	07	C02504-T07P	07

		Accessories		Spare Parts	
		Torx driver for insert locking screw*		Insert locking screw	
For cartridges	For insert size	Designation	Torx Plus	Designation	Torx Plus
	CC...16...	T15P-2	15	C05012-T15P	15
	SC...15...	T15P-2	15	C05012-T15P	15
	TC...16...	T15P-2	15	C03509-T15P	15
	TC...22...	T15P-2	15	C05012-T15P	15

Suitable holders for boring heads

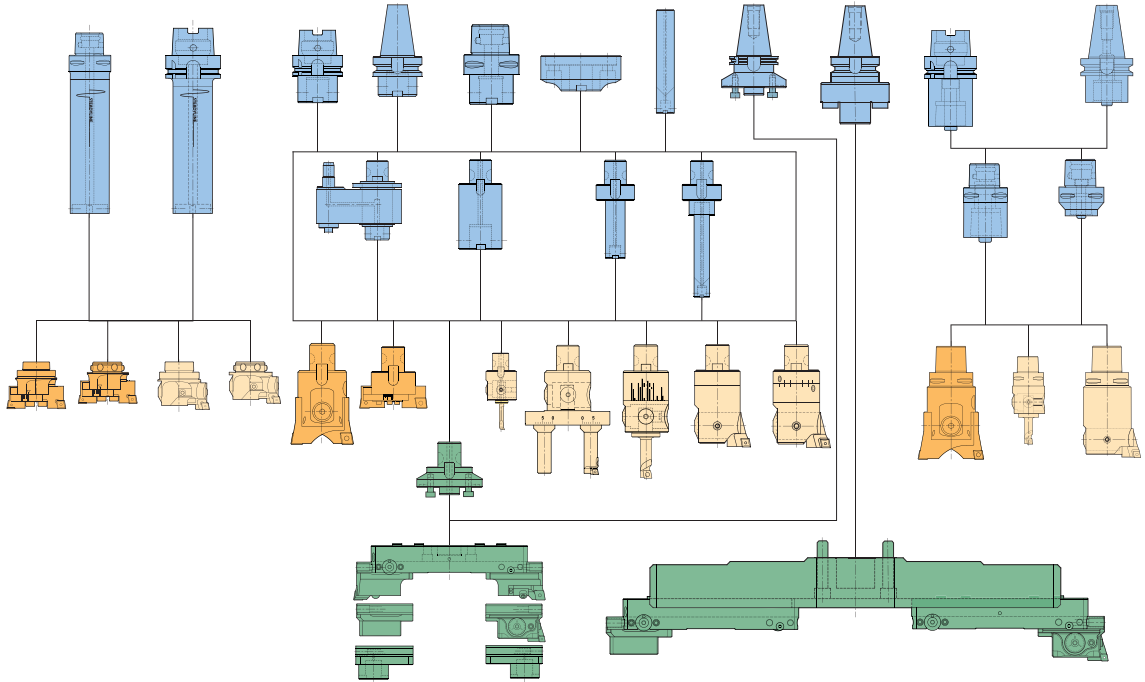

The EPB boring heads feature Graflex®, Seco-Capto™, GL or BA machine side connection

The boring heads can be used on any machine type, using the suitable Graflex® adapter, Seco-Capto™ adapter or Steadyliner® vibration boring/turning bar.

Steadyliner® vibration damping for boring operations

Boring heads with GL or BA machine side connections are designed to be mounted on Steadyliner® boring/turning bars with HSK-T/A and Seco-Capto™ machine side connections. This allows to perform rough and fine boring operations with 6xD, 8xD and 10xD projections, in very stable conditions.

Modular Graflex® and Seco-Capto™ boring bars

All bore lengths up to 6xD can be reached by selecting the required Graflex® intermediates, e.g. the extra-long ones with extension section in carbide. Highest assembly rigidity is obtained by selecting the longest and widest arbor possible, then completing with smaller intermediates. The Graflex® and Seco-Capto™ connections guarantees a unique orientation of the boring heads, achieving a cutting edge orientation according to ISO.

The Graflex® modules are designed to be clamped together by the side.

For boring heads with GL machine side connection for Steadyliner®, select the shortest Steadyliner® bar from the TOOLING SYSTEMS catalogue. These bar exist with HSK-T/A and Seco-Capto™ machine side connection. Other spindle types can be equipped, using the shortest Seco-Capto™ adapters.

For classic boring heads (steel), select the classic Graflex® and Seco-Capto™ arbors and intermediates from the TOOLING SYSTEMS catalogue. For Bridge bars, see Graflex® adapters and direct holders page 463.

Note: Jumbo Bridge bars are designed to be held on milling cutter holders or to be fitted directly on a machine's spindle front.

Locking advice for Graflex® classic connection shanks G. on boring heads (using a tenon with stop screw).

For boring, no need to tighten the tenon's stop screw, as the connection's self locking action is allowed.
For rough boring in heavy duty, we recommend to apply the 'high value' torques for the Graflex® ball nose screws.

See also the detailed 'Graflex® connection assembly procedure' in the TOOLING SYSTEMS catalogue.

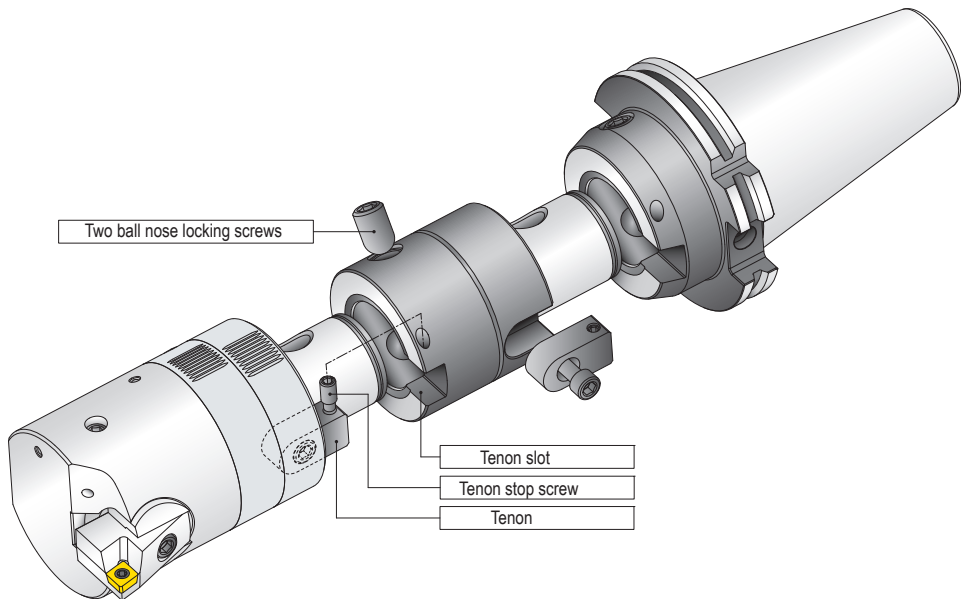

Locking advice for Seco-Capto™ connection shanks C. on boring heads: No specific advice.
For boring heads, the general instructions are applicable, see below.

Tightening torques for Seco-Capto™ receivers connections with centre bolt clamping (Basic Holders, Intermediates)

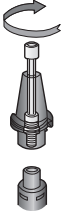
Seco-Capto Size	Centre bolt tightening torque (Nm)	
C3	40-50	
C4	50-60	
C5	90-100	
C6	160-180	
C8	160-180	

Tightening torques for Seco-Capto™ receivers connections with segment clamping, actuated by cam shaft side locking (Flange Mounts)

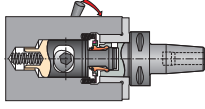
Seco-Capto Size	Cam tightening torque (Nm)	
C3	35	
C4	50	
C5	70	
C6	90	
C8	130	

The Seco-Capto™ joint features a self-locking taper. Where the centre bolt system is used, unscrew the centre bolt until the bolt head makes contact with the tool holder, causing the bolt to force the taper joint apart. When using the cam shaft side clamping system, over tightening of the cam will force the taper joint apart.

Threaded holes – hole size metric ISO threads and inch threads

Tap threading – Thread milling					
Thread	Inch sizes	Pitch	Hole Ø	Tolerance minimum	Tolerance maximum
M2	–	0,4	1,60	1,570	1,670
M2,5	–	0,45	2,05	2,015	2,130
–	UNC4-40	–	2,35	2,160	2,380
M3	–	0,5	2,50	2,470	2,590
–	UNC5-40	–	2,65	2,490	2,690
–	UNC6-32	–	2,85	2,645	2,890
M3,5	–	0,6	2,90	2,850	3,000
M4	–	0,7	3,30	3,250	3,400
–	UNC8-32	–	3,50	3,350	3,530
M4,5	–	0,75	3,70	3,690	3,870
–	UNC10-24	–	3,90	3,685	3,960
M5	–	0,8	4,20	4,140	4,330
–	UNC12-24	–	4,50	4,350	4,590
M6	–	1	5,00	4,920	5,150
–	UNC1/4-20	–	5,10	4,980	5,260
M7	–	1	6,00	5,980	6,260
–	NPT1/16	–	6,15	6,200	TAPER 1:16
–	UNC5/16-18	–	6,60	6,415	6,730
M8	–	1,25	6,80	6,650	6,910
–	UNC3/8-16	–	8,00	7,810	8,160
–	NPT1/8	–	8,40	8,500	TAPER 1:16
M10	–	1,5	8,50	8,380	8,675
–	G1/8	–	8,80	8,570	8,840
–	UNC7/16-14	–	9,40	9,150	9,550
M12	–	1,75	10,20	10,110	10,440
–	UNC1/2-13	–	10,80	10,590	11,010
–	NPT1/4	–	11,10	11,100	TAPER 1:16
–	G1/4	–	11,80	11,445	11,890
M14	–	2	12,00	11,835	12,210
–	UNC5/8-11	–	13,50	13,380	13,860
M16	–	2	14,00	13,835	14,210
–	NPT3/8	–	14,30	14,550	TAPER 1:16
–	G3/8	–	15,25	14,950	15,395
M18	–	2,5	15,50	15,295	15,740
M20	–	2,5	17,50	17,295	17,740
–	NPT1/2	–	17,90	18,000	TAPER 1:16
–	G1/2	–	19,00	18,635	19,170
M22	–	2,5	19,50	19,300	19,740
–	G5/8	–	21,00	20,590	21,120
M24	–	3	21,00	20,760	21,250
–	NPT3/4	–	23,20	23,250	TAPER 1:16
M27	–	3	24,00	23,760	24,250
–	G3/4	–	24,50	24,120	24,650
M30	–	3,5	26,50	26,380	26,670
–	G7/8	–	28,25	27,880	28,415
–	NPT1	–	29,00	29,200	TAPER 1:16
M33	–	3,5	29,50	28,706	29,211
–	G1	–	30,75	30,300	30,930
M36	–	4	32,00	31,670	32,270
M39	–	4	35,00	34,093	35,670
–	G1,1/8	–	35,50	34,940	35,580
M42	–	4,5	37,50	37,220	37,799
–	G1,1/4	–	39,50	38,960	39,590
–	G1,1/2	–	45,25	44,845	45,485

Threaded holes – hole size metric ISO threads and inch threads

Rolled taps (fluteless taps)					
Thread	Inch sizes	Pitch	Hole Ø	Tolerance minimum	Tolerance maximum
M3	–	0,5	2,80	2,78	2,82
M3,5	–	0,6	3,25	3,22	3,28
M4	–	0,7	3,70	3,67	3,73
MF5	–	0,5	4,80	4,78	4,82
M5	–	0,8	4,65	4,62	4,68
M6	–	1	5,55	5,52	5,58
MF6X0,75	–	0,75	5,65	5,62	5,68
MF7	–	0,75	6,65	6,62	6,68
M7	–	1	6,55	6,52	6,58
MF8	–	0,75	7,65	7,62	7,68
MF8	–	1	7,55	7,52	7,58
M8	–	1,25	7,45	7,41	7,49
MF10	–	1	9,55	9,52	9,58
MF10	–	1,25	9,45	9,41	9,49
M10	–	1,5	9,35	9,31	9,39
MF12	–	1	11,55	11,52	11,58
MF12	–	1,25	11,45	11,41	11,49
MF12	–	1,5	11,35	11,31	11,39
M12	–	1,75	11,20	11,15	11,25
MF14	–	1	13,55	13,52	13,58
MF14	–	1,25	13,45	13,41	13,49
MF14	–	1,5	13,35	13,31	13,39
M14	–	2	13,10	13,05	13,15
MF16	–	1,5	15,35	15,31	15,39
M16	–	2	15,10	15,05	15,15
M20	–	2,5	18,90	18,85	18,95
M24	–	3	22,65	22,60	22,70

Threaded holes – hole size metric ISO threads and inch threads

Tap threading – Thread milling – Fine threads					
Thread	Inch sizes	Pitch	Hole Ø	Tolerance minimum	Tolerance maximum
MF4X0,5	–	0,5	3,50	3,459	3,599
–	UNF8-36	–	3,5	3,404	3,607
–	UNF10-32	–	4,1	3,962	4,166
MF5X0,5	–	0,5	4,50	4,459	4,599
MF6X0,75	–	0,75	5,20	5,188	5,378
–	UNF1/4-28	–	5,5	5,367	5,580
–	NPTF1/16	–	6,10	6,200	TAPER 1:16
–	UNF5/16-24	–	6,9	6,792	7,038
MF8X1	–	1	7,00	6,917	7,153
MF8X0,75	–	0,75	7,20	7,188	7,378
–	NPTF1/8	–	8,40	8,500	TAPER 1:16
MF10X1,25	–	1,25	8,80	8,647	8,912
MF10X1	–	1	9,00	8,917	9,153
MF10X0,75	–	0,75	9,20	9,188	9,378
–	UNF7/16-20	–	9,9	9,738	10,030
MF12X1,5	–	1,5	10,50	10,376	10,676
MF12X1,25	–	1,25	10,80	10,647	10,912
MF12X1	–	1	11,00	10,917	11,153
–	NPTF1/4	–	11,00	11,000	TAPER 1:16
–	UNF1/2-20	–	11,5	11,326	11,618
MF14X1,5	–	1,5	12,50	12,376	12,676
MF14X1,25	–	1,25	12,80	12,647	12,912
MF14X1	–	1	13,00	12,917	13,153
–	NPTF3/8	–	14,30	14,500	TAPER 1:16
MF16X1,5	–	1,5	14,50	14,376	14,676
–	UNF5/8-18	–	14,5	14,348	14,671
MF16X1	–	1	15,00	14,917	15,153
MF18X1,5	–	1,5	16,50	16,376	16,676
MF18X1	–	1	17,00	16,917	17,153
–	NPTF1/2	–	17,60	17,800	TAPER 1:16
MF20X1,5	–	1,5	18,50	18,376	18,676
MF20X1	–	1	19,00	18,917	19,153
MF22X1,5	–	1,5	20,50	20,376	20,676
MF24X2	–	2	22,00	21,835	22,210
MF24X1,5	–	1,5	22,50	22,376	22,676
–	NPTF3/4	–	23,00	23,100	TAPER 1:16
MF25X1,5	–	1,5	23,50	23,376	23,676
MF26X1,5	–	1,5	24,50	24,376	24,676
MF27X2	–	2	25,00	24,835	25,210
MF27X1,5	–	1,5	25,50	25,376	25,676
MF28X1,5	–	1,5	26,50	26,376	26,676
MF30X2	–	2	28,00	27,835	28,210
MF30X1,5	–	1,5	28,50	28,376	28,676

ISO Standard tolerance for hole and shaft – Axle tolerances

Axle tolerance position is denominated with **small letters**

Bore tolerance position is denominated with **CAPITAL LETTERS**

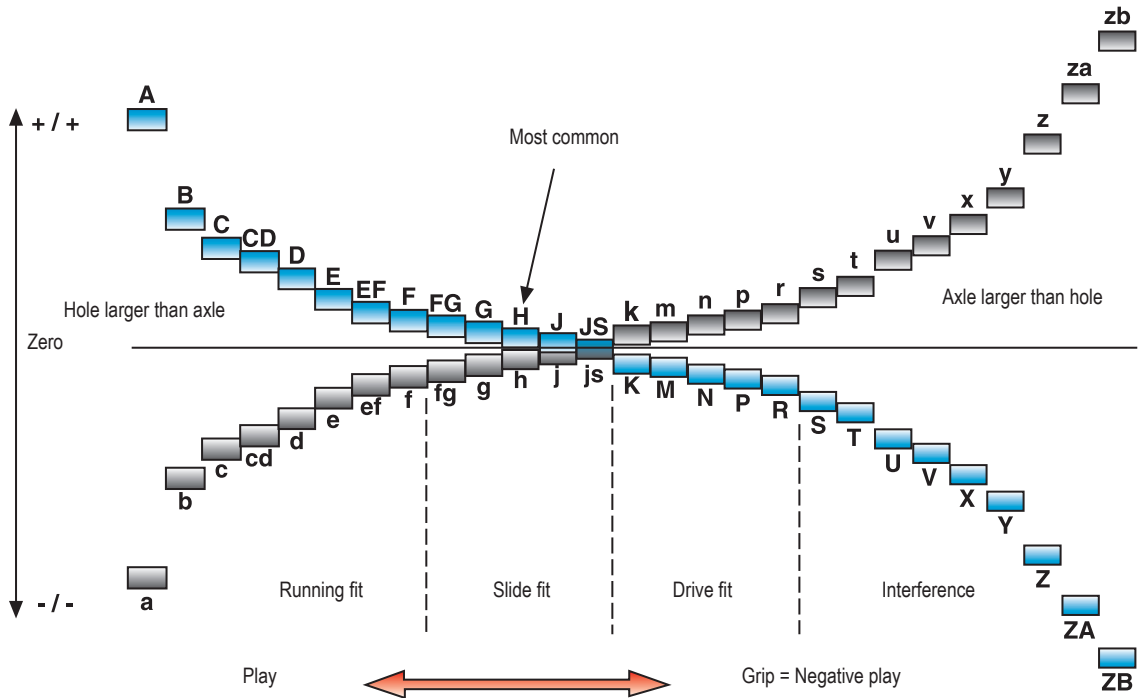
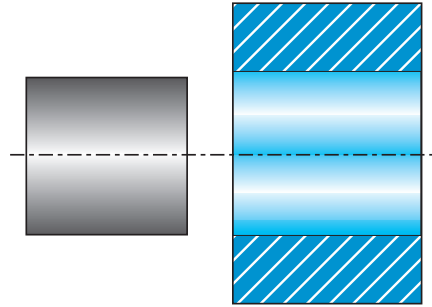



ISO tolerance table

ISO tolerances for holes (μm)													
Hole dia (mm)	D10	E9	F7	F8	G7	G9	H6	H7	H8	H9	H10	H11	H12
≤ 3	+60 +20	+39 +14	+16 +6	+20 +6	+12 +2	+27 +2	+6 0	+10 0	+14 0	+25 0	+40 0	+60 0	+100 0
3 ≥ 6	+78 +30	+50 +20	+22 +10	+28 +10	+16 +4	+34 +4	+8 0	+12 0	+18 0	+30 0	+48 0	+75 0	+120 0
6 ≥ 10	+98 +40	+61 +25	+28 +13	+35 +13	+20 +5	+41 +5	+9 0	+15 0	+22 0	+36 0	+58 0	+90 0	+150 0
10 ≥ 18	+120 +50	+75 +32	+34 +16	+43 +16	+24 +6	+49 +6	+11 0	+18 0	+27 0	+43 0	+70 0	+110 0	+180 0
18 ≥ 30	+149 +65	+92 +40	+41 +20	+53 +20	+28 +7	+59 +7	+13 0	+21 0	+33 0	+52 0	+84 0	+130 0	+210 0
30 ≥ 50	+180 +80	+112 +50	+50 +25	+64 +25	+34 +9	+71 +9	+16 0	+25 0	+39 0	+62 0	+100 0	+160 0	+250 0
50 ≥ 65	+220 +100	+134 +60	+60 +30	+76 +30	+40 +10	-	+19 0	+30 0	+46 0	+74 0	+120 0	+190 0	+300 0
65 ≥ 80													
80 ≥ 100	+260 +120	+159 +72	+71 +36	+90 +36	+47 +12	-	+22 0	+35 0	+54 0	+87 0	+140 0	+220 0	+350 0
100 ≥ 120													
120 ≥ 140	+305 +145	+185 +85	+83 +43	+106 +43	+54 +14	-	+25 0	+40 0	+63 0	+100 0	+160 0	+250 0	+400 0
140 ≥ 160													
160 ≥ 180													
180 ≥ 200	+355 +170	+215 +110	+96 +50	+122 +50	+61 +15	-	+29 0	+46 0	+72 0	+115 0	+185 0	+290 0	+460 0
200 ≥ 225													
225 ≥ 250													
250 ≥ 280	+400 +190	+240 +110	+108 +56	+137 +56	+69 +17	-	+32 0	+52 0	+81 0	+130 0	210 0	+320 0	+520 0
280 ≥ 315													
315 ≥ 355	+440 +210	+265 +125	+119 +62	+151 +62	+75 +18	-	+36 0	+57 0	+89 0	+140 0	+230 0	+360 0	+570 0
355 ≥ 400													

ISO tolerance table

ISO tolerances for holes (µm)												
Hole dia (mm)	H13	JS7	JS9	K6	K7	M6	M7	N7	N9'	P7	P9	R7
≤ 3	+140 0	+/-5	+/-12,5	0 -6	0 -10	-2 -8	-2 -12	-4 -14	-4 -29	-6 -16	-6 -31	-10 -20
3 ≥ 6	+180 0	+/-6	+/-15	+2 -6	+3 -9	-1 -9	0 -12	-4 -16	0 -30	-8 -20	-12 -42	-11 -23
6 ≥ 10	+220 0	+/-7,5	+/-18	+2 -7	+5 -10	-3 -12	0 -15	-4 -19	0 -36	-9 -24	-15 -51	-13 -28
10 ≥ 18	+270 0	+/-9	+/-21,5	+2 -9	+6 -12	-4 -15	0 -18	-5 -23	0 -43	-11 -29	-18 -61	-16 -34
18 ≥ 30	+330 0	+/-10,5	+/-26	+2 -11	+6 -15	-4 -17	0 -21	-7 -28	0 -52	-14 -35	-22 -74	-20 -41
30 ≥ 50	+390 0	+/-12,5	+/-31	+3 -13	+7 -18	-4 -20	0 -25	-8 -33	0 -62	-17 -42	-26 -88	-25 -50
50 ≥ 65	+460 0	+/-15	+/-37	+4 -15	+9 -21	-5 -24	0 -30	-9 -39	0 -74	-21 -51	-32 -106	-30 -62
65 ≥ 80												-32 -62
80 ≥ 100	+540 0	+/-17,5	+/-43,5	+4 -18	+10 -15	-6 -28	0 -35	-10 -45	0 -87	-24 -59	-37 -124	-38 -73
100 ≥ 120												-41 -76
120 ≥ 140	+630 0	+/-20	+/-50	+4 -21	+12 -28	-8 -33	0 -40	-12 -52	0 -100	-28 -68	-43 -143	-48 -88
140 ≥ 160												-50 -90
160 ≥ 180												-53 -93
180 ≥ 200	+720 0	+/-23	+/-57,5	+5 -24	+13 -33	-8 -37	0 -46	-14 -60	0 -115	-33 -79	+50 +165	-60 -106
200 ≥ 225												-63 -109
225 ≥ 250												-67 -113
250 ≥ 280	+810 0	+/-26	+/-65	+5 -27	+16 -36	-9 -41	0 -52	-14 -66	0 -130	-36 -88	-56 -186	-74 -126
280 ≥ 315												-78 -130
315 ≥ 355	+890 0	+/-28,5	+/-70	+7 -29	+17 -40	-10 -46	0 -57	-16 -73	0 -140	-41 -98	-62 -202	-87 -144
355 ≥ 400												-93 -150

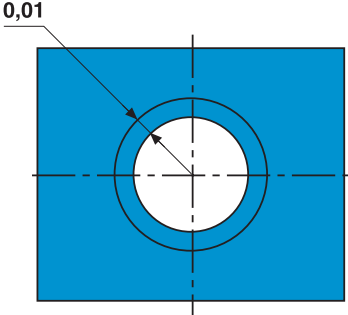
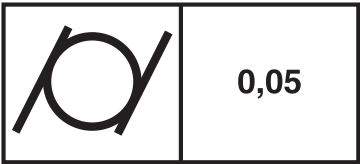
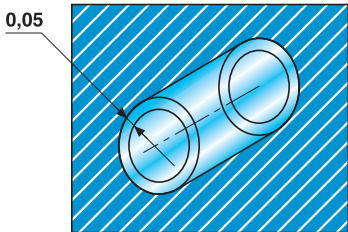
Geometrical tolerance

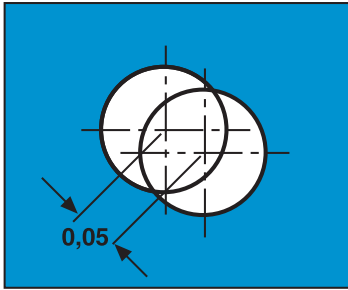
	Drawing symbol	Tolerance area
Circularity		
Cylindricity		
Positioning localisation		

Steels, ferritic and martensitic stainless steels

SMG	Description	Properties	Reference	$k_{c1.1}$	m_c
P1	Free-cutting steels	$360 < R_m < 880$	11 SMn30 $R_m = 385 \text{ N/mm}^2$	1500	0,14
P2	Low-alloy ferritic steels, $C < 0.25\%wt$ Low-alloy weldable general structural steels	$320 < R_m < 600$	S235JRG2 $R_m = 420 \text{ N/mm}^2$	1600	0,23
P3	Ferritic & ferritic/pearlitic steels, $C < 0.25\%wt$ Weldable general structural steels Case-hardening steels	$430 < R_m < 610$	16 MnCr 5 $R_m = 550 \text{ N/mm}^2$	1800	0,14
P4	Low-alloy general structural steels, $0.25\% < C < 0.67\%wt$ Low-alloy Quench & Temper steels	$520 < R_m < 1200$	C 45E $R_m = 660 \text{ N/mm}^2$	2000	0,15
P5	Structural steels, $0.25\% < C < 0.67\%wt$ Quench & Temper steels	$550 < R_m < 1200$	42 CrMo 4 $R_m = 700 \text{ N/mm}^2$	2020	0,18
P6	Low-alloy through-hardening steels, $C > 0.67\%wt$ Low-alloy spring and bearing steels	$520 < R_m < 1200$	C 100S $R_m = 600 \text{ N/mm}^2$	2100	0,17
P7	Through-hardening steels, $C > 0.67\%wt$ Spring and bearing steels	$600 < R_m < 1200$	100 Cr 6 $R_m = 650 \text{ N/mm}^2$	2160	0,17
P8	Tool steels High Speed Steels (HSS)	$600 < R_m < 1200$	X 40 CrMoV 5 1 $R_m = 700 \text{ N/mm}^2$	2400	0,20
P11	Ferritic & martensitic stainless steels	$415 < R_m < 1200$	X 20 Cr 13 $R_m = 675 \text{ N/mm}^2$	2000	0,15
P12	Maraging and precipitation-hardening stainless steels	$500 < R_m < 1200$	X 5 CrNiCuNb 16 4 $R_m = 1100 \text{ N/mm}^2$	2100	0,17

Free-cutting, austenitic and duplex stainless steels

SMG	Description	Properties	Reference	$k_{c1.1}$	m_c
M1	Free-cutting austenitic stainless steels		X 10 CrNiS 18 9	1700	0,14
M2	Low-alloy austenitic stainless steels		X 5 CrNi 18 10	1920	0,18
M3	Medium-alloy austenitic stainless steels		X 2 CrNiMo 18 14 3	2070	0,17
M4	High-alloy austenitic and duplex stainless steels		X 2 CrNiMoN 22 5 3	2230	0,16
M5	Difficult high-alloy austenitic and duplex stainless steels		X 2 CrNiMoN 25 7 4	2510	0,13

Cast irons

SMG	Description	Properties	Reference	k _{c1.1}	m _c
K1	Grey cast irons (GCI)		EN-GJL-250	930	0,32
K2	Compacted graphite irons (CGI)		EN-GJV-400	1000	0,35
K3	Malleable cast irons (MCI)		EN-GJMB-550-4	1050	0,37
K4	Nodular cast irons (SGI)		EN-GJS-500-7	1160	0,37
K5	Austempered ductile irons (ADI)		EN-GJS-1000-5		
K6	Austenitic lamellar cast irons		EN-GJLA-XNiCuCr15-6-2		
K7	Austenitic nodular cast irons		EN-GJSA-XNiMn23-4		

Non-ferrous metals

SMG	Description	Properties	Reference	k _{c1.1}	m _c
N1	Aluminium alloys, Si < 9%		AW-7075		
N2	Aluminium alloys, 9% < Si < 16%		AC-44200 Si = 12%		
N3	Aluminium alloys, Si > 16%		AlSi17Cu5		
N11	Copper alloys		CW614N	740	0,26

Superalloys and titanium

SMG	Description	Properties	Reference	k _{c1.1}	m _c
S1	Iron-based superalloys		Disalloy		
S2	Cobalt-based superalloys		Stellite 21		
S3	Nickel-based superalloys		Inconel 718	2530	0,21
S11	Titanium, low alloyed, (α)		Ti		
S12	Titanium, medium alloyed, (α + β)		TiAl6V4	1500	0,24
S13	Titanium, high alloyed, (near β and β)		Ti10V2Fe3Al		

Hard materials

SMG	Description	Properties	Reference	$k_{c1.1}$	m_c
H3	Case-hardened steels	58 < HRC < 62	16 MnCr 5 60 HRC	2070	0,14
H5	Quenched & Tempered steels	38 < HRC < 56	42 CrMo 4 50 HRC	2320	0,18
H7	Quenched & Tempered steels Bearing steels	56 < HRC < 64	100 Cr 6 60 HRC	2480	0,17
H8	Tool steels High Speed Steels (HSS)	38 < HRC < 64	X 40 CrMoV 5 1 50 HRC	2750	0,20
H11	Martensitic stainless steels	38 < HRC < 50	X 20 Cr 13 45 HRC	2300	0,15
H12	Maraged and precipitation-hardened stainless steels	1200 < R_m < 1650	X 5 CrNiCuNb 16 4 $R_m = 1450 \text{ N/mm}^2$	2410	0,17
H21	Manganese steels	23 < HRC < 64	X 120 Mn 12 50 HRC		
H31	White cast irons	50 < HRC < 64	EN-GJN-HV600(XCr11) 55 HRC		

Other difficult materials

SMG	Description	Properties	Reference	$k_{c1.1}$	m_c
PM1	Low-alloy PM-materials		F-0008 Fe-0.7C		
PM2	Medium-alloy PM-materials		FLC-4608 Fe2Cu1.8Ni 0.5Mo0.2Mn0.8C		
PM3	High-alloy PM-materials Exhaust valve seat materials, etc.				
HF1	Hardfacing alloys Welded or plasma-deposited iron-based alloys				
HF2	Hardfacing alloys Welded or plasma-deposited cobalt- and nickel-based alloys				
CC1	Sintered tungsten carbide		G50		

Plastics and Composites

SMG	Description	Properties	Reference	$k_{c1.1}$	m_c
TS1	Thermosetting polymers		Urea formaldehyde (UF)		
TS2	Thermosetting carbon-fibre composites		T300 T700 T800 HTA-S IMA - Epoxy (M21)...		
TS3	Thermosetting glass-fibre composites		Epoxy - HX..(42..)E glass (7781...)...		
TS4	Thermosetting aramide-fibre composites		Kevlar 49		
TP1	Thermoplastic polymers		Polycarbonate (PC)		
TP2	Thermoplastic carbon-fibre composites		PPS/PEEK - T300..		
TP3	Thermoplastic glass-fibre composites		PPS/PEEK - E glass or A glass...		
TP4	Thermoplastic aramide-fibre composites				

Graphite

SMG	Description	Properties	Reference	$k_{c1.1}$	m_c
GR1	Graphite		R 8500		

SMG

SMG	EN	EN-Nr	W-Nr	DIN	AFNOR	BS	UNI	JIS	SS	UNS
P1	11 SMn 30	1.0715	1.0715	9 SMn 28	S 250	230 M 07	CF 9 SMn 28	SUM 22	1912	G12130
	11 SMnPb 30	1.0718	1.0718	9 SMnPb 28	S 250 Pb		CF 9 SMnPb 28	SUM 22 L	1914	G12134
	10 S 20	1.0721	1.0721	10 S 20	10 F 1	210 M 15	CF 10 S 20			
			1.0722	10 SPb 20	10 PbF 2		CF 10 SPb 20			
	15 SMn 13	1.0725	1.0723	15 S 20		210 A 15		SUM 32	1922	
	35 S20	1.0726	1.0726	35 S 20	35 MF 4	212 M 36			1957	G11400
	46 S20	1.0727	1.0727	46 S 20	45 MF 4	212 M 44			1973	G11460
	11 SMn 37	1.0736	1.0736	9 SMn 36	S 300	240 M 07	CF 9 SMn 36			G12150
	11 SMn 37	1.0736	1.0736	9 SMn 36	S 300	240 M 07	CF 9 SMn 36			G12150
	S235JR	1.0037	1.0037	St 37-2	E 24-2		Fe 360 B	STKM 12 C	1311	
S235JRG2	1.0038	1.0116	St 37-3	E 24-3, E 24-4	4360-40 C	Fe 360 D FF		1312, 1313		
S275J2G3	1.0144	1.0144	St 44-3 N	E 28-3, E 28-4	4360-43 C	Fe 430 D FF	SM 41 C	1412, 1414		
C 10	1.0301	1.0301	C 10	34 C 10, XC 10	045 M 10	C 10	S 10 C		G10100	
		1.0401	C 15	37 C 12, XC 18	080 M 15	C 15, C 16		1350	G10170	
C22	1.0402	1.0402	C 22	C 20	050 A 20	C 20, C 21		1450	G10200	
S355JR	1.0570	1.0570	St 52-3	E 36-3, E 36-4	4360-50 C	Fe 510 B	SM 50 YA	2172, 2132		
C 15R	1.1141	1.1141	Ck 15	XC 15, XC 18	080 M 15	C 15, C 16	S 15 C, S 15 CK	1370	G10170	
		1.1158	Ck 25	XC 25	060 A 25	C 25	S 25 C		G10250	
		1.2162	21 MnCr 5	20 NC 5			SCR 420 H			
P3	16 Mo 3	1.5415	1.5415	15 Mo 3	15 D 3	1501-240	16 Mo 3		2912	
			1.5423	16 Mo 5		1503-245-420	16 Mo 5	SB 450 M		G45200
	14 NiCr 14	1.5752	1.5752	14 NiCr 14	12 NC 15	655 M 13		SNC 815 (H)		G33106
			1.5919	15 CrNi 6	16 NC 6	S 107	16 CrNi 4			
	18 NiCrMo 7 6	1.6587	1.6587	18 CrNiMo 7 6	18 NCD 6	820 A 16	18 NiCrMo 7			
	16 MnCr 5	1.7131	1.7131	16 MnCr 5	16 MC 5	527 M 17	16 MnCr 5	SCR 415	2511	G51170
	16 MnCrS 5	1.7139	1.7139	16 MnCrS 5						
	20 MnCr 5	1.7147	1.7147	20 MnCr 5	20 MC 5		20 MnCr 5	SMnC 420 (H)		G51200
	20 MnCrS 5	1.7149	1.7149	20 MnCrS 5	20 MnCrS 5			SMnC 21 H		
	13 CrMo 4 5	1.7335	1.7335	13 CrMo 4 4	15 CD 3,5	1501-620 Gr. 27	14 CrMo 4 5		2216	
		1.7337	16 CrMo 4 4	15 CD 4,5	1501-620 Gr. 27	14 CrMo 4 5		2216		
10 CrMo 9 10	1.7380	1.7380	10 CrMo 9 10	10 CD 9,10	1501-622 Gr. 31	12 CrMo 9 10		2218	J21890	
P4	C35		1.0501	C 35	55 C 35	060 A 35	C 35		1550	G10350
	E 335	1.0503	1.0503	C 45	65 C 45	80 M 46	C 45	S 45 C	1650	G10430
	C40		1.0511	C 40	60 C 40	080 M 40	C 40	S 40 C		
	E 360	1.0070	1.0535	St 70-2	A 70-2		Fe 690		1655	
	C60	1.0601	1.0601	C 60	CC 55	080 A 62	C 60			G10600
			1.1157	40 Mn 4	35 M 5	150 M 36				G10390
	G 28 Mn6	1.1165	1.1165	30 Mn 5		120 M 36		SMn 1 H, SCMn 2		G13300
	C 35E	1.1181	1.1181	Ck 35	XC 38 H1	080 M 36	C 35	S 35 C	1572	G10340
	C 45E	1.1191	1.1191	Ck 45	XC 42	080 M 46	C 45	S 45 C	1672	G10420
	C 60E	1.1221	1.1221	Ck 60	XC 60	080 A 62	C 60	S 58 C	1665, 1678	G10640
		1.1740	C 60 W	Y3 55			SK 7			
P5	55 SiCr7	1.7100	1.0904	55 Si 7	55 S 7	250 A 53	55 Si 8		2085, 2090	
			1.2330	35 CrMo 4	34 CD 4	708 A 37	35 CrMo 4		2234	T51620
			1.2542	45 WCrV 7		BS 1	45 WCrV 8 KU		2710	T41901
		1.2714	1.2714	56 NiCrMoV 7		BH 224-5	56 NiCrMoV7-KU	SKT 4		T61206
			1.5121	46 MnSi 4						
			1.5710	36 NiCr 6	35 NC 6	640 A 35		SNC 236		
			1.5736	36 NiCr 10	35 NC 11		35 NiCr 9	SNC 631 (H)		
	36 CrNiMo 4		1.6511	36 CrNiMo 4	40 NCD 3	816 M 40	38 NiCrMo 4 (KB)			G98400
	34 CrNiMo 6	1.6582	1.6582	34 CrNiMo 6	35 NCD 6	817 M 40	35 NiCrMo 6 (KW)	SNCM 447	2541	G43400
	34 Cr 4	1.7033	1.7033	34 Cr 4	32 C 4	530 A 32	34 Cr 4 (KB)	SCR 430 (H)		G51320
41 Cr 4	1.7035	1.7035	41 Cr 4	42 C 4	530 M 40	41 Cr 4	SCR 440 (H)		G51400	
25 CrMo 4	1.7218	1.7218	25 CrMo 4	25 CD 4 S	708 M 25	25 CrMo 4 (KB)	SCM 425	2225	G41300	
42 CrMo 4	1.7225	1.7225	42 CrMo 4	42 CD 4	708 M 40	42 CrMo 4	SCM 440 (H)	2244	G41400	
42 CrMo 4	1.7225	1.7225	42 CrMo 4	42 CD 4	708 M 40	42 CrMo 4	SCM 440 (H)	2244	G41400	
		1.7361	32 CrMo 12	30 CD 12	722 M 24	32 CrMo 12		2240		
50 CrV 4	1.8159	1.8159	50 CrV 4	50 CV 4	735 A 50	51 CrV 4	SUP 10	2230	H61500	
41 CrAlMo 7 10	1.8509	1.8509	41 CrAlMo 7	40 CAD 6.12	905 M 39	41 CrAlMo 7	SACM 645	2940	K24065	
P6	C 67S	1.1231	1.1231	Ck 67	XC 68	060 A 67	C 70		1770	G10700
	C 100S	1.1274	1.1274	Ck 101		060 A 96		SUP 4	1870	G10950
	C 105U	1.1545	1.1545	C 105 W1	Y1 105		C 100 KU	SK 3		
			1.1663	C 125 W	Y2 120		C 120 KU	SK 2		

SMG

U.N.E./I.H.A.	AISI / ASTM	GOST	ČSN	Misc. Brands	Condition	Structure
	1213				Annealed	
	12 L 13				Annealed	
	1108				Annealed	
	11 L 08				Annealed	
					Annealed	
	1140	40			Annealed	
	1146				Annealed	
	1215				Annealed	
	12 L 14				Annealed	
		16D			Annealed	
	A573 Grade 58	18kp	11 378		Annealed	
	A573 Grade 70	S114kP	11 448		Annealed	
	1010	10			Annealed	
F.1110	1015	15			Annealed	
	1020, 1023	20	12 024		Annealed	
		17G1S	11 523		Annealed	
F.1511	1015	15			Annealed	
F.1120	1025	25			Annealed	
					Annealed	
	A204 Grade A		15 020		Annealed	
	4520				Annealed	
	3310, 9314	20X2H4A	16 420		Annealed	
	4320		16 220		Annealed	
					Annealed	
F.1516	5115	12KHN2	14 220		Annealed	
		18HG			Annealed	
	5120	20KH	14 221		Annealed	
	5120 H	20KH			Annealed	
	A182-F11, A182-F12	12KHM	15 121		Annealed	
	A387 Grade 12 Cl. 2				Annealed	
F.155	A182-F22	12KH8	15 313		Annealed	
F.1130	1035	35	12 040		Annealed	
F.5110	1045	45	12 050		Annealed	
	1040	40	12 041		Annealed	
F.1150	1055	55			Annealed	
	1060	60	12 061		Annealed	
	1039	40G			Annealed	
	1330	30G2			Annealed	
F.1135	1035	35			Annealed	
F.1140	1045	45	12 050		Annealed	
F.1150	1064	60			Annealed	
	1060	60			Annealed	
F.144	9255	55S2			Annealed	
F.1250	4135	35KHM			Annealed	
F.5241	S1	5KHV2S			Annealed	
	L6	5KHNV			Annealed	
	5045				Annealed	
	3135				Quenched & Tempered	
	3435				Annealed	
	9840				Quenched & Tempered	
F.1280	4340	38H2N2MA	16 343		Annealed	
	5132	35KH			Quenched & Tempered	
	5140	40H	14 140		Quenched & Tempered	
F.1251	4130	20KHM	15 130		Quenched & Tempered	
F.1252	4142, 4140	38HM	15 142		Annealed	
F.1252	4142, 4140	38HM	15 142		Quenched & Tempered	
					Quenched & Tempered	
F.143	6150	50KHFA	15 260		Quenched & Tempered	
F.1740	A355 Cl. A				Annealed	
F.5103	1070	70			Annealed	
F.5117	1095				Annealed	
F.5118	W1	U10A			Annealed	
		U10			Annealed	
	W1	U13			Annealed	

SMG

SMG	EN	EN-Nr	W.-Nr	DIN	AFNOR	BS	UNI	JIS	SS	UNS
P7	107 CrV 3	1.2210	1.2210	115 CrV 3	100 C 3		107 CrV 3 KU			T61202
			1.2510	100 MnCrW 4	90 MWCV 5	BO 1	95 MnWCr 5 KU	SKS 3	2140	T31501
	90 MnCrV 8	1.2842	1.2842	90 MnCrV 8	90 MV 8	BO 2	90 MnVCr 8 KU			T31502
	100 Cr 6	1.3505	1.3505	100 Cr 6	100 C 6	534 A 99	100 Cr 6	SUJ 2	2258	G51986
P8	X 210 Cr 12	1.2080	1.2080	X 210 Cr 12	Z 200 C 12	BD 3	X 210 Cr 13 KU	SKD 1		T30403
			1.2343	X 38 CrMoV 5 1	Z 38 CDV 5	BH 11	X 37 CrMoV 5 1 KU	SKD 6		T20811
	X 40 CrMoV 5 1	1.2344	1.2344	X 40 CrMoV 5 1	Z 40 CDV 5	BH 13	X 40 CrMo 5 1 1 KU	SKD 61	2242	T20813
	X 100 CrMoV 5	1.2363	1.2363	X 100 CrMoV 5 1	Z 100 CDV 5	BA 2	X 100 CrMoV 5 1 KU	SKD 12	2260	T30102
			1.2365	X 32 CrMoV 3 3	32 DCV 28	BH 10	30 CrMoV 12 27 KU	SKD 7		T20810
			1.2436	X 210 CrW 12			X 215 CrW 12 1 KU	SKD 2	2312	
			1.2601	X 165 CrMoV 12			X 165 CrMoV 12 KU		2310	
			1.2713	55 NiCrMoV 6	55 NCDV 7			SKT 4		T61206
	HS 6-5-2-5	1.3243	1.3243	S 6-5-2-5	Z 85 WDKCV 06-05-04-02		HS 6-5-2-5	SKH 55	2723	
	HS 2-10-1-8	1.3247	1.3247	S 2-10-1-8	Z 110 DKCWV 09-08-04	BM 42	HS 2-9-1-8	SKH 51		T11342
	HS 18-1-2-5	1.3255	1.3255	S 18-1-2-5	Z 80 WKCVC 18-05-04-01	BT 4	HS 18-1-1-5	SKH 3		T12004
	HS 6-5-2	1.3343	1.3343	S 6-5-2	Z 85 WDCV 06-05-04-02	BM 2	HS 6-5-2	SKH 9, SKH 51	2722	T11302
HS 2-9-2	1.3348	1.3348	S 2-9-2	Z 100 DCWV 09-04-02-02		HS 2-9-2	SKH 58	2782	T11307	
HS 18-0-1	1.3355	1.3355	S 18-0-1	Z 80 WCV 18-04-01	BT 1	HS 18-0-1	SKH 2		T12001	
P11	X 6 Cr 13	1.4000	1.4000	X 6 Cr 13	Z 6 C 12	403 S 17	X 6 Cr 13	SUS 403	2301	S41008
	X 12 Cr 13	1.4006	1.4006	X 10 Cr 13	Z 10 C 13	410 S 21	X 12 Cr 13	SUS 410	2302	S41000
	X 6 Cr 17	1.4016	1.4016	X 6 Cr 17	Z 8 C 17	430 S 15	X 8 Cr 17	SUS 430	2320	S43000
	X 20 Cr 13	1.4021	1.4021	X 20 Cr 13	Z 20 C 13	420 S 37	X 20 Cr 13	SUS 420 J 1	2303	S42000
	X 39 Cr 13	1.4031	1.4031	X 40 Cr 13	Z 40 C 14	420 S 45	X 40 Cr 14	SUS 420	2304	S40280
	X 70 CrMo 15	1.4109	1.4109	X 65 CrMo 14	Z 70 D 14			SUS 440 A		S44002
	X 90 CrMoV 18	1.4112	1.4112	X 90 CrMoV 18	Z 2 CND 18 05	409 S 19	X CrTi 12	SUS 440 B	2327	S44003
	X 105 CrMo 17	1.4125	1.4125	X 105 CrMo 17	Z 100 CD 17		X 105 CrMo 17	SUS 440 C		S44004
	X 3 CrNiMo 13 3	1.4313	1.4313	X 5 CrNi 13 4	Z 5 CN 13.4	425 C 11	X 6 CrNi 13 04	SCS 5	2385	S41500
	X 18 CrN 28	1.4749	1.4749	X 18 CrN 28	Z 18 C 25				2322	S44600
	X 6 NiCrTiMoV 25 15	1.4534	1.4534	X 3 CrNiMoAl 13 8 2						S13800
P12	X 4 CrNiCuNb 16 4	1.4540	1.4540	X 4 CrNiCuNb 16 4						S15500
		1.4540	1.4540	X 4 CrNiCuNb 16 4	Z 4 CNUNb 16.4 M					S15500
	X 4 CrNiCuNb 16 4	1.4540	1.4540	X 4 CrNiCuNb 16 4						S15500
	X 5 CrNiCuNb 16 4	1.4542	1.4542	X 5 CrNiCuNb 16 4				SUS 630		S17400
	X 5 CrNiCuNb 17 4	1.4548	1.4542	X 5 CrNiCuNb 17 4	Z 6 CNU 17.4			SCS 24, SUS 630		S17400
	X 7 CrNiAl 17 7	1.4564	1.4564	X 7 CrNiAl 17 7	Z 9 CAN 17.7	301 S 81	X 7 CrNiAl 17 7	SUS 631	2388	S17700
	X 2 NiCoMoTi 18 12 4	1.6356	1.6356	X 2 NiCoMoTi 18 12 4						K93160
	X 2 NiCoMoTi 18 9 5	1.6358	1.6358	X 2 NiCoMoTi 18 9 5	Z 2 NKD 19-09					K93120
	X 2 NiCoMo 18 9 5	1.6358	1.6358	X 2 NiCoMoTi 18 9 5	Z 2 NKD 19-09					K93120
	X 2 NiCoMo 18 8 5	1.6359	1.6359	X 2 NiCoMo 18 8 5		S 162				K92890
X 2 NiCoMo 18 8 5	1.6359	1.6359	X 2 NiCoMo 18 8 5		S 162				K92890	
M1	X 10 CrNiS 18 9	1.4305	1.4305	X 10 CrNiS 18 9	Z 10 CNF 18.09	303 S 31	X 10 CrNi 18 09	SUS 303	2346	S30300
	X 2 CrNi 19 11	1.4306	1.4306	X 2 CrNi 19 11	Z 2 CN 18.10	304 S 12	X 3 Cr Ni 18 11	SUS 304 L	2352	S30403
M2	X 5 CrNi 18 10	1.4301	1.4301	X 5 CrNi 18 10	Z 6 CN 18.09	304 S 31	X 5 CrNi 18 11	SUS 304	2333	S30400
	X 5 CrNiMo 17 12 2	1.4401	1.4401	X 5 CrNiMo 17 12 2	Z 3 CND 17.11.1	316 S 31	X 5 CrNiMo 17 12	SUS 316	2347	S31600
	X 6 CrNiNb 18 10	1.4550	1.4550	X 6 CrNiNb 18 10	Z 6 CENNb 18.10	347 S 31	X 6 CrNiNb 18 11	SUS 347	2338	S34700
	X 9 CrNi 18 8	1.4310	1.4310	X 12 CrNi 17 7	Z 12 CN 17.07	301 S 21	X 12 CrNi 17 07	SUS 301	(2331)	S30100
	X 12 CrNi 18 8	1.4300	1.4300	X 12 CrNi 18 8	Z 12 CN 18	302 S 25		SUS 302	2331	S30200
M3	X 2 CrNiMo 18 14 3	1.4435	1.4435	X 2 CrNiMo 18 14 3	Z 2 CND 17.13	316 S 12	X 2 CrNiMo 17 13 2	SCS 16, SUS 316 L	2353	S31603
	X 2 CrNiMoN 17 13 3	1.4429	1.4429	X 2 CrNiMoN 17 13 3	Z 2 CND 17.13 Az	316 S 62	X 2 CrNiMoN 17 13 3	SUS 316 LN	2375	S31653
	X 2 CrNiN 18 10	1.4311	1.4311	X 2 CrNiN 19 11	Z 2 CN 18. 10 Az	304 S 62	X 2 CrNiN 18 11	SUS 304 LN	2371	S30453
	X 3 CrNiMo 18 12 3	1.4466	1.4466	X 5 CrNi 18 15		317 S 16	X 5 CrNi 18 15	SUS 317	2366	S31700
	X 9 CrNiSiNc 21 11 2	1.4835	1.4893	X 9 CrNiSiNc 21 11 2		310 S 31			2368	S30815
M4	X 12 CrNi 25 21	1.4335	1.4335	X 12 CrNi 25 21	Z 12 CN 25.20	310 S 24	X 6 CrNi 26 20	SUH 310, SUS 310 S	2361	S31008
	X 2 CrNiMo 22 5 3	1.4462	1.4462	X 2 CrNiMoN 22 5	Z 2 CND 22.05 Az	332 S 15	X 2 CrNiMo 22 5		2377	S31803
	X 2 CrNiMoSi 19 5	1.4424	1.4417	X 2 CrNiMoSi 19 5	Z 2 CND 18.05.03				2376	S31500
	X 2 NiCrMoCu 25 20 5	1.4539	1.4539	X 2 NiCrMoCu 25 20 5	Z 2 NCDU 25 20	904 S 13			2562	N08904
	X 3 CrNiMo 27 5 2	1.4460	1.4460	X 4 CrNiMo 27 5 2	Z 3 CND 25.7 Az		X 3 CrNiMo 27 5 2	SUS 329 J 1	2324	S32900
M5	X 5 CrNiCuNb 16 4	1.4980	1.4943	X 4 NiCrTi 25 15	Z 6 NCTDV 25.15	HR 51		SUH 660	2570	S66286
	X 1 CrNiMoN 20 18 7	1.4547	1.4529	X 1 CrNiMoN 20 18 7	Z 1 CNDU 20.18.05 Az		X 1 CrNiMoN 20 18 7		2778	S31254
	X 1 CrNiMo 25 22 8	1.4652	1.4652	X 2 CrNiMoN 25 22 7						S32654
	X 10 NiCrAlTi 32 20	1.4876	1.4876	X 10 NiCrAlTi 32 20	Z 10 NC 32.21			NCF 800		N08800
	X 2 CrNiMoN 25 7 4	1.4410	1.4410	X 2 CrNiMoN 25 7 4	Z 3 CND 25.07 Az		X 2 CrNiMoN 25 7 4		2328	S32750

SMG

U.N.E./ I.H.A.	AISI / ASTM	GOST	ČSN	Misc. Brands	Condition	Structure
F.520L	L2	11KHF			Annealed	
F.5220	O1	9KHVG			Annealed	
	O2	9G2F			Annealed	
F.5230	52100	SHKH15	14 109		Annealed	
F.5212	D3	KH12			Annealed	
	H11	4KH5MFS			Annealed	
F.5318	H13	4KH5MF1S			Annealed	
F.5227	A2	9KH5VF			Annealed	
	H10	3KH3M3F			Annealed	
F.5213		KH12			Annealed	
		KH12MF			Annealed	
F.520.S	L6	5KHNM			Annealed	
F.5613	M35	R6M5K5			Annealed	
	M42	R2AM9K5			Annealed	
	T4	R18K5F2			Annealed	
F.5603	M2	R6M5			Annealed	
	M7				Annealed	
	T1	R18			Annealed	
	403	08KH13			Annealed	Ferritic
F.3401	410, CA-15	12KH13, 08KH13			Annealed	Martensitic
F.3113	430	12KH17			Annealed	Ferritic
F.5261	420	20KH13	17 022		Annealed	Martensitic
F.3404	420	40KH13			Annealed	Martensitic
	440 A				Annealed	Martensitic
	440 B	95KH18			Annealed	Martensitic
	440 C	95KH18			Annealed	Martensitic
	A182 F6NM			F6NM	Annealed	Martensitic
	446	15KH28			Annealed	Ferritic
	XM-13			PH 13-8 Mo	Solution annealed	Austenitic
	XM-12			15-5 PH	H1150	Martensitic
	XM-12			15-5 PH	Solution annealed	Martensitic
	XM-12			15-5 PH	H1025	Martensitic
	SAE 630			17-4 PH	H1150	Martensitic
	630			17-4 PH	Solution annealed	Martensitic
	631	09KH17N7YU1		17-7 PH	Solution annealed	Austenitic/Ferritic
	AMS 6515			Marage 350	Solution annealed	Martensitic
	AMS 6521			Marage 300	Solution annealed	Martensitic
	AMS 6514			Marage 300, Vascomax C300	Solution annealed	Martensitic
	AMS 6512			Marage 250	Solution annealed	Martensitic
	AMS 6512			Marage 250, Vascomax C250	Solution annealed	Martensitic
F.3508	303	12KH19N9			Annealed	Austenitic
F.3504	304 L	03KH18N11			Annealed	Austenitic
F.3504	304	08KH18N10	17 240		Annealed	Austenitic
F.3534	316	08KH17H13M2T	17 346		Annealed	Austenitic
F.3524	347	08KH18N12B			Annealed	Austenitic
F.3517	301	07KH16N6			Annealed	Austenitic
	302	12KH18N9			Annealed	Austenitic
F.3533	(316 L)	03KH17N14M3	17 349		Annealed	Austenitic
	316 LN	03KH16N15M3			Annealed	Austenitic
F.3541	304 LN	03KH18N11			Annealed	Austenitic
	317	08KH17H15M3T			Annealed	Austenitic
				253 MA	Annealed	Austenitic
	310 S	12KH25N20			Annealed	Austenitic
	329 LN			SAF 2205	Annealed	Duplex
				3RE60	Annealed	Duplex
	904L				Annealed	Super austenitic
	329				Annealed	Duplex
	660			A286	Solution annealed	Austenitic
				254 SMO	Annealed	Super austenitic
				654 SMO	Annealed	Super austenitic
				Alloy 800	Annealed	Austenitic
	F 53			SAF 2507	Annealed	Super duplex

SMG

SMG	EN	EN-Nr	W.-Nr	DIN	AFNOR	BS	UNI	JIS	SS	UNS
K1	EN-GJL-150	0.6150	0.6150	GG-15	F1 15 D	Grade 150	G15	FC 150	01 15-00	F11601
	EN-GJL-200	0.6200	0.6200	GG-20	F1 20 D	Grade 220	G20	FC 200	01 20-00	F12101
	EN-GJL-250	0.6250	0.6250	GG-25	F1 25 D	Grade 260	G25	FC 250	01 25-00	F12401
	EN-GJL-350	0.6350	0.6350	GG-35	F1 35 D	Grade 350	G35	FC 350	01 35-00	F13502
	EN-GJL-215			GG-220 HB					02 19	
K2	EN-GJV-300			GJV-300						
	EN-GJV-350			GJV-350						
	EN-GJV-400			GJV-400						
	EN-GJV-450			GJV-450						
	EN-GJV-500			GJV-500						
K3	EN-GJMB-550-4	0.8155		GTS-55-04	P 540/5	P 540/5	P 55-04	PCMP55-04	08 54-00	F24130
K4	EN-GJS-350-22	0.7033	0.7033	GGG-35.3	FGS 370-17	Grade 350/22		FCD 350-22L	07 17-15	
	EN-GJS-400-15	0.7040	0.7040	GGG-40	FGS 400-12	Grade 420/12	GS 400-12	FCD 400-18L	07 17-02	F32800
	EN-GJS-400-18	0.7043	0.7043	GGG-40.3	FGS 370-17	Grade 370/17	GSO 42/17		07 17-12	F32800
	EN-GJS-500-7	0.7050	0.7050	GGG-50	FGS 500-7	Grade 500/7	GS 500-7	FCD 500-7	07 27-02	F33800
	EN-GJS-600-3	0.7060	0.7060	GGG-60	FGS 600-3	Grade 600/3	GS 600-3	FCD 600-3	07 32-03	F34100
	EN-GJS-700-2	0.7070	0.7070	GGG-70	FGS 700-2	Grade 700/2	GS 700-2	FCD 700-2	07 37-01	F34800
K5	EN-GJS-1000-5			GJS-1000-5						ADI grade 5
	EN-GJS-1200-2			GJS-1200-2						ADI grade 2
	EN-GJS-1400-1			GJS-1400-1						ADI grade 3
	EN-GJS-800-8			GJS-800-8						ADI grade 4
K6	EN-GJLA-XNiCr 20-2	0.6660	0.6660	GGL-NiCr 20 2	FGL Ni20 Cr2	Grade F2			05 23-00	F41002
	EN-GJLA-XNiCr 30-3	0.6676	0.6676	GGL-NiCr 30 3	FGL Ni30 Cr3	Grade F3				F41004
	EN-GJLA-XNiCuCr 15-6-2	0.6655	0.6655	GGL-NiCuCr 15 6 2	FGL Ni15 Cu6 Cr2	Grade F1				F41000
K7	EN-GJSA-XNiMn 13-7	0.7652	0.7652	GGG-NiMn 13 7	FGS Ni13 Mn7	Grade S6			07 72-00	
	EN-GJSA-XNiCr 20-2	0.7660	0.7660	GGG-NiCr 20 2	FGS Ni20 Cr2	Grade S2				F43000
	EN-GJSA-XNiMn 23-4	0.7673	0.7673	GGG-NiMn 23 4	FGS Ni23 Mn4	Grade S2M				F43010
	EN-GJSA-XNiCr 30-3	0.7676	0.7676	GGG-NiCr 30 3	FGS Ni30 Cr3	Grade S3				F43003
	EN-GJSA-XNi 35	0.7683	0.7683	GGG-Ni 35	FGS Ni35					F43006
N1	AW-1050A	Al99.5	3.0255	Al99.5	A-5/1050A	1B		(A1050)	4007	AA1050A
	AW-2011	AlCuBiPb	3.1655	AlCuBiPb	A-U5PbBi/2011	FC1		A2011	4355	AA2011
	AW-2014	AlCuSiMn	3.1255	AlCuSiMn	A-U4SG/2014	H15			4338	AA2014
	AW-5005	AlMg1	3.3315	AlMg1	A-G0.6	N41			4106	AA5005
	AW-6060	AlMgSi0.5	3.3206	AlMgSi0.5	A-GS/6060	(H9)			4103	AA6060
	AW-6063	AlMgSi0.7	3.3210	AlMgSi0.7	A-GSUC/6061	(H10)		(A6063)	4104, 4107	AA6005
	AW-3103	AlMn1	3.0515	AlMn1		N3			4054	AA3103
	AW-3003	AlMn1Cu	3.0517	AlMn1Cu	A-M1/3003			A3003		AA3003
	AW-7020	AlZn4.5Mg1	3.4335	AlZn4.5Mg1	A-Z5G/7020	H17			4425	AA7020
	AW-7075		3.4365	AlZnMgCu1.5	A-Z5GU/7075	2L95/2L96			A7075	AA7075
	AC-42000		3.2341	G-AlSi5Mg	A-S7G	LM25	3599		AC 4C	4244
	AC-46200	AlSi8Cu3(Si)	3.2161	G-AlSi8Cu3					4251	A13800
	MG-P-63	MgAl6Zn	3.5612	G-MgAl6Zn	G-A6-Z1	MAG-E-121				M11600
	MG-P-61	MgAl8Zn	3.5812	G-MgAl8Zn	(G-A7-Z1)					
	MN65120	MgSe3Zn2Zr1	3.5103	G-MgSe3Zn2Zr1	ZRE1	MAG6-TE				M12330
N2	AC-43400	AlSi10Mg(Fe)	3.2381	G-AlSi10Mg	A-S10G	LM9			4253	A13600
	AC-44200	AlSi12	3.2382	GD-AlSi12						
	AW-6082	AlMgSi1	3.2315	AlMgSi1	A-SGM0.7/6082	H30			4212	AA6082
N3		AlSi17Cu5					ADC14			
N11	CC331G		2.0940.01	CuAl10Fe	CuAl10Fe	AB1			5710	C95200
	CC333G		2.0975.01	CuAl10Ni	CuAl10Ni5Fe5	AB2			5716	C95500
		CuNi10Fe1Mn	2.0872	CuNi10Fe1Mn	CuNi10Fe1Mn	CN102			5667	C70600
				CuNi10Zn45						
		CW408J	2.0790	CuNi18Zn19Pb	CuNi18Zn19Pb1					C76300
	CW352H		2.1176	CuPb10Sn	CuSn10Pb10	LB2			5640	C93700
	CC480K		2.1050.01	CuSn10	CuSn10	CT1			5443	C90700
			2.1087	CuSn10Zn					5458	C90500
	CW452K	CuSn6	2.1020	CuSn6	CuSn6	PB103		C5191	5428	C51900
	CW502L	CuZn15	2.0240	CuZn15	CuZn15	CZ102		C2300	5112	C23000
	CW706R	CuZn28Sn1	2.0470	CuZn28Sn1	CuZn29Sn1				5220	C44300
	CW508L	CuZn37	2.0321	CuZn37	CuZn37	CZ108			5150	C27200
	CW717R	CuZn38Sn1	2.0530	CuZn38Sn1						C46400
	CW614N	CuZn39Pb3	2.0401	CuZn39Pb3	CuZn39Pb3	CZ121			5170	C38500
	CW612N	CuZn40Pb2	2.0402	CuZn40Pb2	CuZn39Pb2	CZ120			5168	C37800
CW622N	CuZn44Pb2	2.0410	CuZn44Pb2		CZ104			5272	C68700	

SMG

SMG	EN	EN-Nr	W-Nr	DIN	AFNOR	BS	UNI	JIS	SS	UNS	
S1											
S2											
S3	NiMo30		2.4810							N10002	
	NiMo16Cr15W		2.4819							N10276	
	NiCr19Fe19Nb5Mo3		2.4668							N07718	
	NiCr20TiAl		2.4631							N07750	
	NiCr19Co18Mo4Ti3Al3									N07080	
	NiCr20Co13Mo4Ti3Al		2.4654							N07500	
S11			3.7024							N07001	
S12										R54620	
S12	TiAl6V4		3.7164							R56320	
S13				TiV10Fe2Al3						R56400	
H3	16 MnCr 5	1.7131	1.7131	16 MnCr 5	16 MC 5	527 M 17	16 MnCr 5	SCR 415	2511	G51170	
	C 67S	1.1231	1.1231	Ck 67	XC 68	060 A 67	C 70		1770	G10700	
H5	C 75S	1.1248	1.1248	Ck 75	XC 75	060 A 78	C 75		1774, 1778	G10780	
	C 100S	1.1274	1.1274	Ck 101		060 A 96		SUP 4	1870	G10950	
	C 105U	1.1545	1.1545	C 105 W1	Y1 105				1880		
			1.2550	60 WCrV 7	55 WC 20			55 WCrV 8 KU			
	55 Cr 3	1.7176	1.7176	55 Cr 3	55 C 3	527 A 60	55 Cr 3	SUP 9 (A)	2253	G51550	
	42 CrMo 4	1.7225	1.7225	42 CrMo 4	42 CD 4	708 M 40	42 CrMo 4	SCM 440 (H)	2244	G41400	
H7	107 CrV 3	1.2210	1.2210	115 CrV 3	100 C 3		107 CrV 3 KU			T61202	
			1.2510	100 MnCrW 4	90 MWCV 5	BO 1	95 MnWCr 5 KU	SKS 3	2140	T31501	
	90 MnCrV 8	1.2842	1.2842	90 MnCrV 8	90 MV 8	BO 2	90 MnVCr 8 KU			T31502	
	100 Cr 6	1.3505	1.3505	100 Cr 6	100 C 6	534 A 99	100 Cr 6	SUJ 2	2258	G51986	
H8	X 40 CrMoV 5 1	1.2344	1.2344	X 40 CrMoV 5 1	Z 40 CDV 5	BH 13	X 40 CrMo 5 1 1 KU	SKD 61	2242	T20813	
	X 100 CrMoV 5	1.2363	1.2363	X 100 CrMoV 5 1	Z 100 CDV 5	BA 2	X 100 CrMoV 5 1 KU	SKD 12	2260	T30102	
	X 155 CrVMo 12 1		1.2379	X 155 CrVMo 12 1	Z 160 CDV 12	BD 2	X 155 CrVMo 12 1 KU	SKD 11		T30402	
			1.2436	X 210 CrW 12			X 215 CrW 12 1 KU	SKD 2		2312	
			1.2601	X 165 CrMoV 12			X 165 CrMoW 12 KU			2310	
			1.2713	55 NiCrMoV 6	55 NCDV 7			SKT 4			T61206
	HS 6-5-2-5	1.3243	1.3243	S 6-5-2-5	Z 85 WDKCV 06-05-05-04-02		HS 6-5-2-5	SKH 55	2723		
HS 2-10-1-8	1.3247	1.3247	S 2-10-1-8	Z 110 DKCWV 09-08-	BM 42	HS 2-9-1-8	SKH 51			T11342	
HS 18-0-1	1.3355	1.3355	S 18-0-1	Z 80 WCV 18-04-01	BT 1	HS 18-0-1	SKH 2			T12001	
H11	X 20 Cr 13	1.4021	1.4021	X 20 Cr 13	Z 20 C 13	420 S 37	X 20 Cr 13	SUS 420 J 1	2303	S42000	
	X 70 CrMo 15	1.4109	1.4109	X 65 CrMo 14	Z 70 D 14			SUS 440 A		S44002	
	X 90 CrMoV 18	1.4112	1.4112	X 90 CrMoV 18	Z 2 CND 18 05	409 S 19	X CrTi 12	SUS 440 B	2327	S44003	
	X 105 CrMo 17	1.4125	1.4125	X 105 CrMo 17	Z 100 CD 17		X 105 CrMo 17	SUS 440 C		S44004	
H12	X 4 CrNiCuNb 16 4	1.4540	1.4540	X 4 CrNiCuNb 16 4						S15500	
	X 5 CrNiCuNb 16 4	1.4542	1.4542	X 5 CrNiCuNb 16 4				SUS 630		S17400	
	X 5 CrNiCuNb 16 4	1.4542	1.4542	X 5 CrNiCuNb 16 4				SUS 630		S17400	
	X 7 CrNiAl 17 7	1.4568	1.4568	X 7 CrNiAl 17 7	Z 9 CAN 17.7	301 S 81	X 7 CrNiAl 17 7	SUS 631	2388	S17700	
	X 8 CrNiMoAl 15 7 5	1.4574	1.4574	X 8 CrNiMoAl 15 7 5						S15700	
	X 6 NiCrTiMoV 25 15	1.4980	1.4943	X 4 NiCrTi 25 15	Z 6 NCTDV 25.15	HR 51		SUH 660	2570	S66286	
	X 2 NiCoMo 18 8 5	1.6359	1.6359	X 2 NiCoMo 18 8 5		S 162				K92890	
	X 2 NiCoMoTi 18 9 5	1.6358	1.6358	X 2 NiCoMoTi 18 9 5	Z 2 NKD 19-09					K93120	
X 2 NiCoMoTi 18 9 5	1.6358	1.6358	X 2 NiCoMoTi 18 9 5	Z 2 NKD 19-09					K93120		
X 2 NiCoMoTi 18 12 4	1.6356	1.6356	X 2 NiCoMoTi 18 12 4						K93160		
H21	X 120 Mn 12	1.3401	1.3401	X 120 Mn 12	Z 120 M 12	BW 10		SC MnH 1	2183		
H31	EN-GJN-HV520	0.9620	0.9620	G-X330 NiCr 4 2	FB Ni4 Cr2 BC	Grade 2 A			05 12-00	F45001	
	EN-GJN-HV550	0.9625	0.9625	G-X260 NiCr 4 2	FB Ni4 Cr2 HC	Grade 2 B			05 13-00	F45000	
	EN-GJN-HV600(XCr11)	0.9630	0.9630	G-X300 CrNiSi 9 5 2	FB Cr9 Ni5	Grade 2 C, D, E			04 57-00	F45003	

SMG

U.N.E./I.H.A.	AISI / ASTM	GOST	ČSN	Misc. Brands	Condition	Structure
				Discalloy	Precipitation hardened	
				Haynes 25		
				Stellite 21		
				Hastelloy C		
		KHN65MV		Hastelloy C-276		
				IN 100		
				Inconel 718		
				Inconel X-750	Solution annealed	
				Nimonic 80A		
				René 41		
				Udimet 500		
				Waspalloy		
				Ti	Commercially pure	Ti (α)
	AMS 4919			Ti 6-2-4-2	Annealed	Ti (α)
	AMS 4943			Ti 3Al-2.5V (grd 9)	Annealed	Ti (α+β)
	AMS 4920, Grade 5	VT6		Ti 6Al-4V	Annealed	Ti (α+β)
	AMS 4986			Ti 10V-2Fe-3Al	Annealed	Ti (β)
F.1516	5115	12KHN2	14 220		Case hardened	
F.5103	1070	70			Quenched & Tempered	
F.5107	1078, 1080	75			Quenched & Tempered	
F.5117	1095				Quenched & Tempered	
F.5118	W1	U10A			Quenched & Tempered	
	S1	5KHV2SF			Quenched & Tempered	
	5155				Quenched & Tempered	
F.1252	4142, 4140	38HM	15 142		Quenched & Tempered	
F.520L	L2	11KHF			Quenched & Tempered	
F.5220	O1	9KHVG			Quenched & Tempered	
	O2	9G2F			Quenched & Tempered	
F.5230	52100	SHKH15	14 109		Quenched & Tempered	
F.5318	H13	4KH5MF1S			Quenched & Tempered	
F.5227	A2	9KH5VF			Quenched & Tempered	
F.5211	D2	KH12MF			Quenched & Tempered	
F.5213		KH12			Quenched & Tempered	
		KH12MF			Quenched & Tempered	
F.520.S	L6	5KHNM			Quenched & Tempered	
F.5613	M35	R6M5K5			Quenched & Tempered	
	M42	R2AM9K5			Quenched & Tempered	
	T1	R18			Quenched & Tempered	
F.5261	420	20KH13	17 022		Quenched & Tempered	Martensitic
	440 A				Quenched & Tempered	Martensitic
	440 B	95KH18			Quenched & Tempered	Martensitic
	440 C	95KH18			Quenched & Tempered	Martensitic
	XM-12			15-5 PH	H900	Martensitic
	SAE 630			17-4 PH	H1025	Martensitic
	SAE 630			17-4 PH	H900	Martensitic
	AMS 5528	09KH17N7YU1		17-7 PH	TH1050	Martensitic
	632			PH 15-7 Mo	TH1050	Martensitic
	660			A286	Precipitation hardened	Austenitic
	AMS 6512			Marage 250	Precipitation hardened	Martensitic
	AMS 6521			Marage 300	Precipitation hardened	Martensitic
	AMS 6521			Marage 300	Precipitation hardened	Martensitic
	AMS 6515			Marage 350	Precipitation hardened	Martensitic
	A128 Grade A			Hadfield		
	A532 IB (NiCr-LC)			Ni-Hard 2		White cast iron
	A532 IA (NiCr-HC)			Ni-Hard 1		White cast iron
	A532 ID (Ni-HiCr)			Ni-Hard 4		White cast iron

Cemented carbide inserts and insert carriers

Cemented carbide inserts and cemented carbide insert carriers from Seco Tools are not included in the product range intended for the following requirements. Nevertheless Seco Tools can make the following declaration.

These products meet all requirements in RoHS (Restriction of the use of certain Hazardous Substances in electrical and electronic equipment), WEEE (Waste Electrical & Electronic Equipment) and ELV (End of Life Vehicles) requirements.

Products do not contain mercury, lead, hexavalent chromium, cadmium, CFC, HCFC, flame retardants or solvents in concentrations that exceed specifications in the regulations.

Regrinding:

Wet or dry grinding can produce potentially hazardous dusts or mists that can irritate skin, eyes, nose, throat and result in lung damage or disease. To avoid injury use proper safety precautions and protective equipment.

Disposal:

Seco Tools will buy back used inserts and solid carbide tools for recycling. Inserts and solid carbide tools should be separated from other metal waste (steel, aluminium, copper etc).

All packing material is fully recyclable.

CBN and PCD inserts

Inserts from Seco Tools are not included in the product range intended for the following requirements. Nevertheless Seco Tools can make the following declaration.

This product meets all requirements in RoHS (Restriction of the use of certain Hazardous Substances in electrical and electronic equipment), WEEE (Waste Electrical & Electronic Equipment) and ELV (End of Life Vehicles) requirements.

Products do not contain mercury, lead, hexavalent chromium, cadmium, CFC, HCFC, flame retardants or solvents in concentrations that exceed specifications in the regulations.

Regrinding:

Wet or dry grinding can produce potentially hazardous dusts or mists that can irritate skin, eyes, nose, throat and result in lung damage or disease. To avoid injury use proper safety precautions and protective equipment.

Disposal:

Seco Tools will buy back used CBN- or PCD-tipped inserts for recycling. Inserts should be separated from other metal waste (steel, aluminium, copper etc). Solid CBN-inserts may be discarded as landfill waste.

All packing material is fully recyclable.

Black oxide insert carriers

Insert carriers from Seco Tools are not included in the product range intended for the following requirements. Nevertheless Seco Tools can make the following declaration.

This product meets all requirements in RoHS (Restriction of the use of certain Hazardous Substances in electrical and electronic equipment), WEEE (Waste Electrical & Electronic Equipment) and ELV (End of Life Vehicles) requirements.

Products do not contain mercury, lead, hexavalent chromium, cadmium, CFC, HCFC, flame retardants or solvents in concentrations that exceed specifications in the regulations.

Disposal:

Used insert carriers may be sent for recycling together with ordinary steel waste (swarf and discarded steel scrap) for recycling.

All packing material is fully recyclable.

Cermet inserts

Inserts from Seco Tools are not included in the product range intended for the following requirements. Nevertheless Seco Tools can make the following declaration.

This product meets all requirements in RoHS (Restriction of the use of certain Hazardous Substances in electrical and electronic equipment), WEEE (Waste Electrical & Electronic Equipment) and ELV (End of Life Vehicles) requirements.

Cermet grade C15M inserts do contain nickel and will leach nickel when in contact with the skin. Amount of leaching is higher than specified in norm SS-EN 1811 Reference test method for release of nickel from products intended to come into direct and prolonged contact with the skin. These norms are intended for products that are in direct and prolonged contact with the skin and are therefore not directly applicable for cermet inserts. Persons with known allergic reactions to nickel are advised to wear protective gloves when handling cermet inserts.

Regrinding:

Wet or dry grinding can produce potentially hazardous dusts or mists that can irritate skin, eyes, nose, throat and result in lung damage or disease. To avoid injury use proper safety precautions and protective equipment.

Disposal:

Used inserts may be recycled. Inserts should be separated from other metal waste (steel, aluminium, copper, etc) including cemented carbide inserts.

All packing material is fully recyclable.

Nickel coated insert carriers

Insert carriers from Seco Tools are not included in the product range intended for the following requirements. Nevertheless Seco Tools can make the following declaration.

This product meets all requirements in RoHS (Restriction of the use of certain Hazardous Substances in electrical and electronic equipment), WEEE (Waste Electrical & Electronic Equipment) and ELV (End of Life Vehicles) requirements.

Products do not contain mercury, lead, hexavalent chromium, cadmium, CFC, HCFC, flame retardants or solvents in concentrations that exceed specifications in the regulations.

Insert carriers do contain nickel and will leach nickel when in contact with the skin. Amount of leaching is not higher than norm SS-EN 1811 Reference test method for release of nickel from products intended to come into direct and prolonged contact with the skin.

These norms are intended for products that are in direct and prolonged contact with the skin and are therefore not directly applicable for insert carriers. Persons with known allergic reactions to nickel are advised to wear protective gloves when handling nickel coated insert carriers.

Disposal:

Used tools maybe sent for recycling together with ordinary steel waste (swarf and discarded steel scrap) for recycling.

All packing material is fully recyclable.

Intentionally added alloying elements

Grade	Cemented carbide												Coating						
	W	Ti	Ta	Nb	Co	Cr	Ni	Mo	C	N	Ru	Ti	Al	C	N	O	Si	Nb	
CP20	■				■				■			■			■				
CP200	■				■	■			■			■	■		■				
CP300	■	■	■	■	■				■			■	■		■				
CP500	■				■	■			■			■	■		■				
CP600	■				■	■			■			■	■		■				
C15M	■	■	■	■	■			■	■	■									
CF	■				■			■	■	■									
CM	■				■			■	■	■									
DP2000	■				■				■			■	■		■	■			
DP3000	■	■			■				■			■	■	■	■	■			
DS2050	■				■	■			■			■	■		■				■
DS4050	■				■	■			■			■	■		■				■
F15M	■				■	■			■			■	■		■				
F25M	■	■	■	■	■				■			■	■		■				
F30M	■				■	■			■			■	■		■				
F40M	■				■	■			■			■	■		■				
HX	■				■				■										
H02	■				■	■			■			■							
H15	■				■	■			■			■							
H25	■				■	■			■			■							
KX	■				■	■			■			■							
MH1000	■				■	■			■			■	■		■				
MK1500	■				■				■			■	■	■	■	■			
MK2050	■				■	■			■			■	■		■			■	
MM4500	■				■	■			■			■	■	■	■	■			
MP1020	■	■			■				■			■			■				
MP1500	■				■				■			■			■	■			
MP2050	■				■				■			■			■			■	
MP2500	■				■				■			■			■	■			
MP3000	■				■	■			■			■			■	■			
MS2500	■				■	■			■			■			■	■			
MS2050	■				■	■			■			■			■	■			■
RX1500	■				■				■	■		■			■				
RX2000	■				■	■			■			■			■				
RM2020	■				■				■			■			■				
RM2090	■				■	■			■			■			■			■	
RN2010	■				■	■			■			■			■			■	
RS2090	■				■	■			■			■			■			■	
T350M	■				■	■			■			■			■	■			
T25M	■				■	■			■			■			■				
TGH1050	■				■	■			■			■			■			■	
TGK1500	■				■				■			■			■			■	
TGP25	■	■			■	■			■			■			■	■			
TGP35	■				■	■			■			■			■	■			
TGP45	■				■	■			■			■			■	■			
TH1000	■				■	■			■			■			■	■			■
TH1500	■				■	■			■			■			■	■			■
TK0501	■				■	■			■			■			■	■			■
TK1501	■				■	■			■			■			■	■			■
TM2000	■	■	■	■	■				■			■			■	■			■
TM4000	■	■	■	■	■				■	■		■			■	■			■
TP0501	■	■	■	■	■	■			■			■			■	■			■
TP1020	■	■	■	■	■				■			■			■				■
TP1030	■	■	■	■	■				■			■			■				■
TP1501	■	■	■	■	■				■	■		■			■	■			■
TP200	■	■	■	■	■				■			■			■	■			■
TP2501	■	■	■	■	■	■			■			■			■	■			■
TP3501	■	■	■	■	■				■	■		■			■	■			■
TP40	■				■				■			■			■				■
TS2000	■				■	■			■			■			■				■
TS2050	■				■	■			■			■			■				■
TS2500	■				■				■			■			■				■
T250D	■				■	■			■			■			■				■
T400D	■				■	■			■			■			■				■
T100R	■				■	■			■			■			■				■
T60M	■	■	■	■	■				■			■			■				■
883	■				■				■			■							■
890	■				■	■			■			■							■

This work is published with the understanding that Seco Tools and its editors are supplying information aimed to present a general orientation and direction of metal cutting and related sciences. If professional services are required for specific applications, the assistance of an appropriate professional should be acquired.

The information is provided “as is”;

Seco Tools and its editors disclaim all representations and warranties, express or implied, of any kind, including, without limitations, any warranties of merchantability, fitness for a particular purpose, title, or non-infringement. In no event will Seco Tools or its editors be liable to any party for any direct, indirect, special or other consequential damages for any use of the information, even if Seco Tools or its editors are advised of the possibility of such damage.

The information provided herein is for reference purposes only. Actual prices, specifications, and product descriptions are finalised at the time of sale and may vary by location. The information provided herein is subject to change without prior notice.

WWW.SECOTOOLS.COM

03272166, ST20186680 GB,
© SECO TOOLS AB, 2019. All rights reserved.
Technical specifications are subject to
change without notice.