

GUHRING

MQL

BY GUHRING



GM300 | MQL-Program

EDITION 2015

GUHRING - YOUR WORLD-WIDE PARTNER

MQL

GUHRING MQL SYSTEMS

DELIVERING
ONLY THE
REQUIRED AMOUNT



As one of the pioneers of MQL technology we have an extensive knowledge of minimal quantity lubrication. Guhring standard MQL Chucks have been supplied a thousand fold throughout the world and are recognised by the automotive industry as ideal MQL solutions as either the one or two channel systems.

Higher cutting speeds and longer tool life are possible thanks to adapted cooling as well as highest surface qualities thanks to the pure lubricant. Workpieces and chips remain dry! Save the cost of de-greasing your workpieces as well as disposal of swarf and soluble oil.

1 MQL BY GÜHRING

Our products for the MQL 1-channel technology are identified by this symbol.

**Visual feature
of the 1-channel system**
is the gold coloured MQL
length setting screw.



2 MQL BY GÜHRING

Our products for the MQL 2-channel technology are identified by this symbol.

**Visual feature
of the 2-channel system**
is the black coloured MQL
length setting screw.



MQL 1-CHANNEL SYSTEM

from page 7

Hydraulic chucks	8
Shrink fit chucks	10
Accessories	14
Synchro-chucks	19

MQL-CHECK 3000

from page 47

MMS 2-CHANNEL SYSTEM

from page 20

Hydraulic chucks	21
Shrink fit chucks	24
Accessories	30
Synchro-chucks	35

TECHNICAL INFORMATION

from page 48

HSK CLAMPING TECHNOLOGY

from page 37

GühroClamp MQL 4-point clamping sets	43
M-contour clamping sets for MQL and IC	45

MQL SYSTEM FINDER

			HSK-A for automatic tool change	HSK-A for manual tool change
1 MQL BY GÜHRING	Hydraulic chucks		4210, p. 9	4209, p. 8
	Shrink fit chucks		4741, p. 12	4735, p. 10
	Synchro-chucks		4330, p. 19	4298, p. 19
2 MQL BY GÜHRING	Hydraulic chucks		4612, p. 22	4611, p. 21
	Shrink fit chucks		4614, p. 27	4613, p. 24
	Synchro-chucks		4341, p. 35	4298, p. 35

automatic tool change

manual tool change

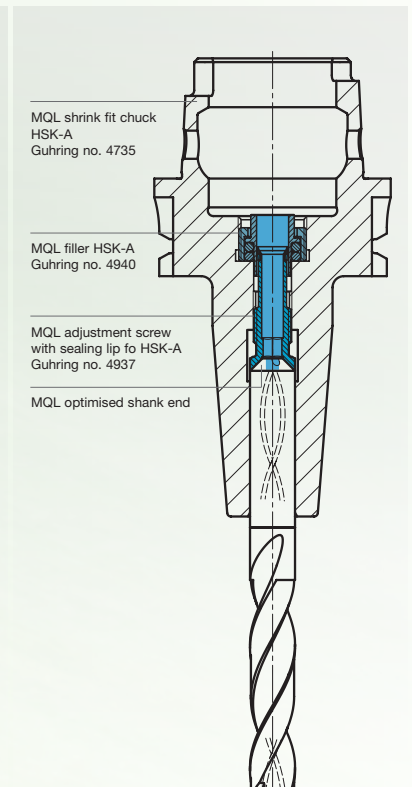
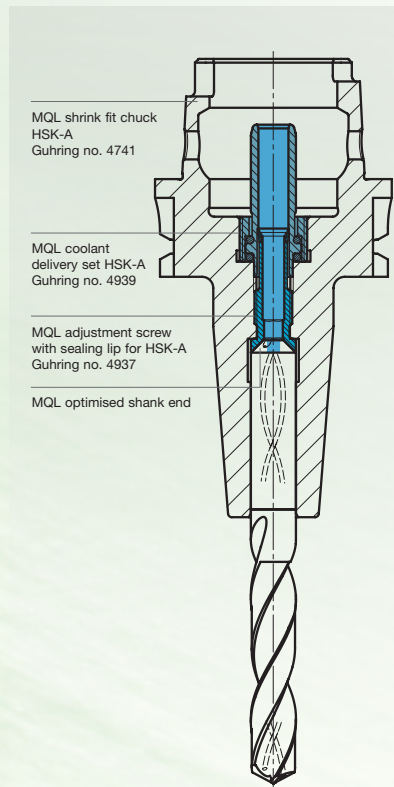



MQL

TECHNOLOGY AND ADVANTAGES

- ⇒ Cost reduction due to reduced cleaning
- ⇒ Environment & health protection
- ⇒ Less cooling lubrication requirement – high coolant effect
- ⇒ Low process temperatures
- ⇒ Lower working temperature at tool point
- ⇒ Instant cooling lubricant delivery
- ⇒ Direct response without losses
- ⇒ High compatibility

MQL

BY GÜHRING



Our products for the MQL 1-channel technology are identified by this symbol.

Visual feature of the 1-channel system is the gold coloured MQL length setting screw.

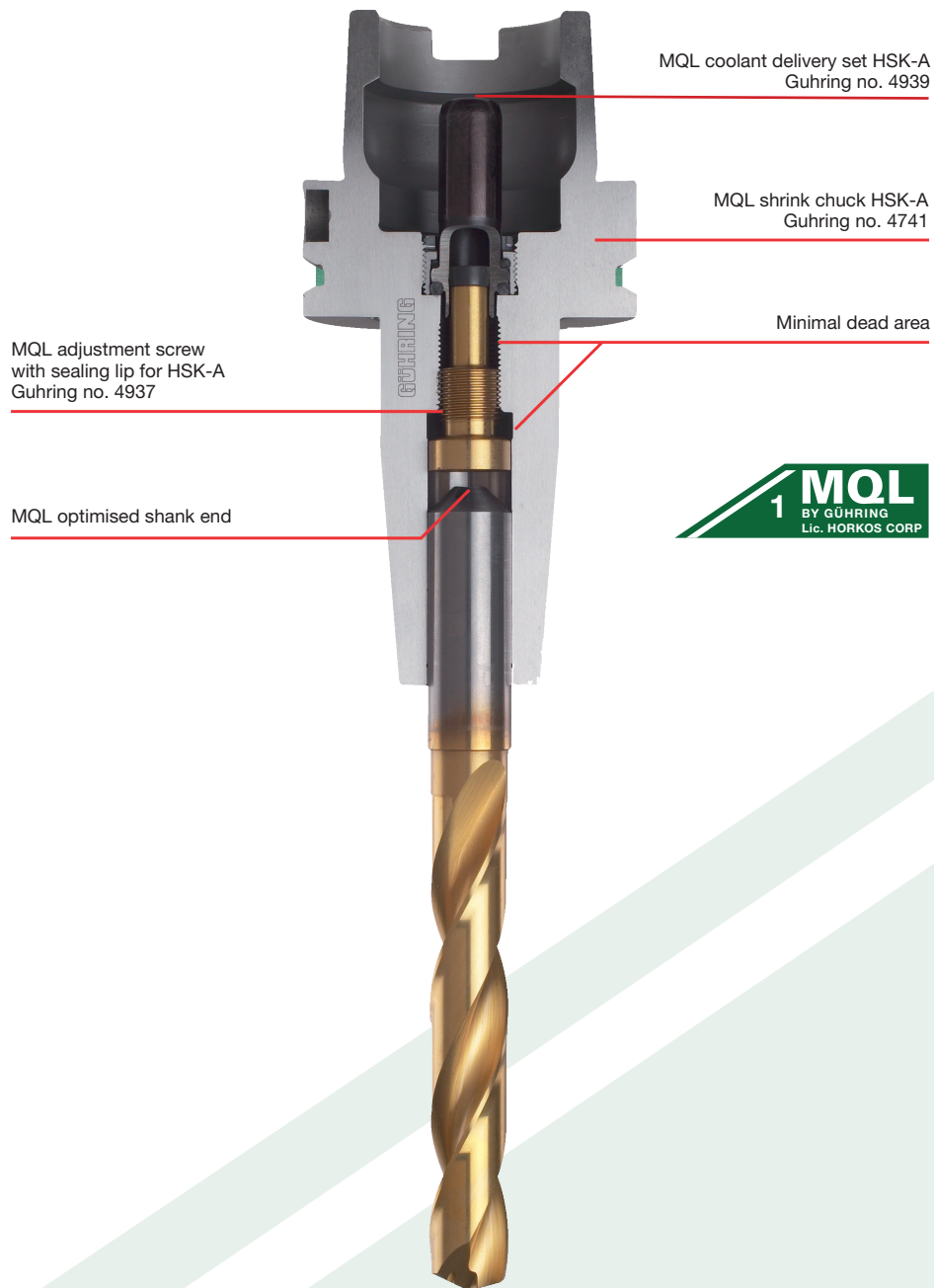

Product information

- to Guhring MQL standard
- for 1-channel-systems
- balancing quality: G6.3 / 15,000 rev./min
- for tool shank tolerance h6
- axial length setting

Scope of delivery

- incl. MQL adjustment screw with sealing lip Guhring no. 4937 and MQL coolant delivery set Guhring no. 4940 (filler)
- incl. hexagon chuck key Guhring no. 4912

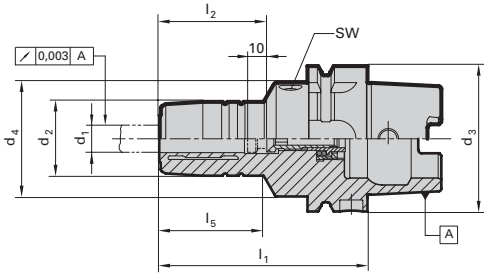

Guhring no. 4209

Discount group 147

HSK-A d ₃	for shank Ø d ₁ h6 mm	d ₂ mm	d ₄ mm	l ₁ mm	l ₂ mm	l ₅ mm	incl. setting screw no. 4937 ...	SW	kg	Code no.	Availability
50	6	26	40	80	36	38.0	6,050	4	0.95	6,050	●
50	8	28	40	80	36	38.0	8,050	4	0.95	8,050	●
50	10	30	40	85	40	44.0	10,050	4	0.95	10,050	●
50	12	32	40	90	45	49.0	12,050	4	0.95	12,050	●
50	14	34	40	90	45	49.0	14,050	4	0.95	14,050	●
50	16	38	53	95	48	36.0	16,050	5	1.25	16,050	●
50	18	40	57	95	48	36.0	18,050	5	1.25	18,050	●
50	20	42	60	100	50	39.0	20,050	5	1.25	20,050	●
63	6	26	50	80	36	34.5	6,100	5	1.25	6,063	●
63	8	28	50	80	36	35.5	8,100	5	1.25	8,063	●
63	10	30	50	85	40	40.0	10,100	5	1.25	10,063	●
63	12	32	50	90	45	45.0	12,100	5	1.35	12,063	●
63	14	34	50	90	45	46.0	14,100	5	1.35	14,063	●
63	16	38	50	95	48	51.0	16,100	5	1.45	16,063	●
63	18	40	50	95	48	52.0	18,100	5	1.45	18,063	●
63	20	42	50	100	50	58.0	20,100	5	1.45	20,063	●
63	25	57	63	115	56	50.0	25,100	6	2.45	25,063	●
63	32	64	75	120	60	58.0	32,100	6	3.10	32,063	●
100	6	26	50	85	36	36.0	6,100	5	2.60	6,100	●
100	8	28	50	85	36	36.0	8,100	5	2.60	8,100	●
100	10	30	50	90	40	42.0	10,100	5	2.60	10,100	●
100	12	32	50	95	45	47.0	12,100	5	2.65	12,100	●
100	14	34	50	95	45	47.0	14,100	5	2.65	14,100	●
100	16	38	50	100	48	53.0	16,100	5	2.85	16,100	●
100	18	40	50	100	48	53.0	18,100	5	2.85	18,100	●
100	20	42	50	105	50	59.0	20,100	5	3.35	20,100	●
100	25	57	63	115	56	67.0	25,100	6	3.50	25,100	●
100	32	64	75	120	60	72.0	32,100	6	3.95	32,100	●

Product information

- to Guhring MQL standard
- for 1-channel-systems
- balancing quality: G6.3 / 15,000 rev./min
- for tool shank tolerance h6
- axial length setting

Scope of delivery

- incl. MQL adjustment screw with sealing lip Guhring no. 4937 and MQL coolant delivery set Guhring no. 4939
- incl. hexagon chuck key Guhring no. 4912

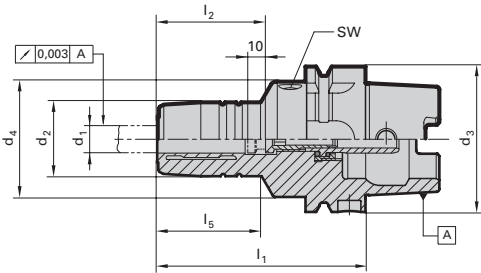

Guhring no. **4210**

Discount group **147**

HSK-A d ₃	for shank Ø d ₁ h ₆ mm	d ₂ mm	d ₄ mm	l ₁ mm	l ₂ mm	l ₅ mm	incl. setting screw no. 4937 ...	SW	kg	Code no.	Availability
50	6	26	40	80	36	38.0	6,050	4	0.95	6,050	●
50	8	28	40	80	36	38.0	8,050	4	0.95	8,050	●
50	10	30	40	85	40	44.0	10,050	4	0.95	10,050	●
50	12	32	40	90	45	49.0	12,050	4	0.95	12,050	●
50	14	34	40	90	45	49.0	14,050	4	0.95	14,050	●
50	16	38	53	95	48	36.0	16,050	5	1.25	16,050	●
50	18	40	57	95	48	36.0	18,050	5	1.25	18,050	●
50	20	42	60	100	50	39.0	20,050	5	1.25	20,050	●
63	6	26	50	80	36	34.5	6,100	5	1.25	6,063	●
63	8	28	50	80	36	35.5	8,100	5	1.25	8,063	●
63	10	30	50	85	40	40.0	10,100	5	1.25	10,063	●
63	12	32	50	90	45	45.0	12,100	5	1.35	12,063	●
63	14	34	50	90	45	46.0	14,100	5	1.35	14,063	●
63	16	38	50	95	48	51.0	16,100	5	1.45	16,063	●
63	18	40	50	95	48	52.0	18,100	5	1.45	18,063	●
63	20	42	50	100	50	58.0	20,100	5	1.45	20,063	●
63	25	57	63	115	56	50.0	25,100	6	2.45	25,063	●
63	32	64	75	120	60	58.0	32,100	6	3.10	32,063	●
100	6	26	50	85	36	36.0	6,100	5	2.60	6,100	●
100	8	28	50	85	36	36.0	8,100	5	2.60	8,100	●
100	10	30	50	90	40	42.0	10,100	5	2.60	10,100	●
100	12	32	50	95	45	47.0	12,100	5	2.65	12,100	●
100	14	34	50	95	45	47.0	14,100	5	2.65	14,100	●
100	16	38	50	100	48	53.0	16,100	5	2.85	16,100	●
100	18	40	50	100	48	53.0	18,100	5	2.85	18,100	●
100	20	42	50	105	50	59.0	20,100	5	3.35	20,100	●
100	25	57	63	115	56	67.0	25,100	6	3.50	25,100	●
100	32	64	75	120	60	72.0	32,100	6	3.95	32,100	●

MQL 1-channel shrink fit chucks HSK-A for manual tool change

Product information

- to Guhring MQL standard
- for 1-channel-systems
- balancing quality: G6.3 / 15,000 rev./min
- incl. balancing thread 4xM6/6xM6
- for tool shank tolerance h6
- also available in the lengths l1 = 120 mm and 160 mm (concentricity 5 µm)

Scope of delivery

- incl. MQL adjustment screw with sealing lip Guhring no. 4937 and MQL coolant delivery set Guhring no. 4940
- special dimensions on request

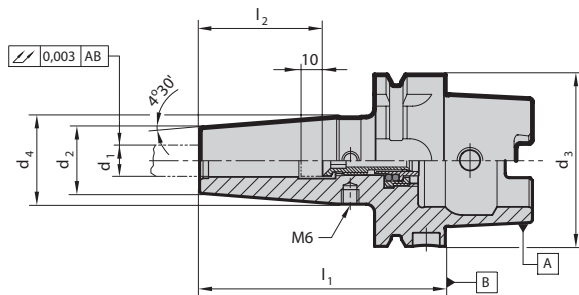

Guhring no. **4735**

Discount group **148**

HSK-A d ₃	for shank Ø d ₁ h ₆ mm	d ₂ mm	d ₄ mm	l ₁ mm	l ₂ mm	incl. setting screw no. 4937 ...	kg	Code no.	Availability
40	6	21	27	80	36	6,040	0.40	6,040	●
40	8	21	27	80	36	8,040	0.40	8,040	●
40	10	24	32	80	40	10,040	0.50	10,040	●
40	12	24	32	90	45	12,040	0.50	12,040	●
40	14	27	34	90	45	14,040	0.60	14,040	●
40	16	27	34	90	48	16,040	0.50	16,040	●
50	6	21	27	80	36	6,050	0.60	6,050	●
50	8	21	27	80	36	8,050	0.60	8,050	●
50	10	24	32	85	40	10,050	0.70	10,050	●
50	12	24	32	90	45	12,050	0.70	12,050	●
50	14	27	34	90	45	14,050	0.70	14,050	●
50	16	27	34	95	48	16,050	0.70	16,050	●
50	18	33	42	95	48	18,050	0.90	18,050	●
50	20	33	42	100	50	20,050	0.90	20,050	●
63	6	21	27	80	36	6,100	0.70	6,063	●
63	8	21	27	80	36	8,100	0.70	8,063	●
63	10	24	32	85	40	10,100	0.70	10,063	●
63	12	24	32	90	45	12,100	0.80	12,063	●
63	14	27	34	90	45	14,100	0.80	14,063	●
63	16	27	34	95	48	16,100	0.90	16,063	●
63	18	33	42	95	48	18,100	0.90	18,063	●
63	20	33	42	100	50	20,100	1.00	20,063	●
63	25	44	53	115	56	25,100	1.00	25,063	●
63	32	44	53	120	60	32,100	1.10	32,063	●
63	6	21	27	120	36	6,032	0.90	806,063	●
63	8	21	27	120	36	8,040	1.00	808,063	●
63	10	24	32	120	40	10,050	1.10	810,063	●
63	12	24	32	120	45	12,100	1.20	212,063	●
63	14	27	34	120	45	14,100	1.40	214,063	●
63	16	27	34	120	48	16,100	1.40	216,063	●
63	18	33	42	120	48	18,100	1.60	218,063	●
63	20	33	42	120	50	20,100	1.60	220,063	●
63	6	21	27	160	36	6,032	0.80	906,063	●
63	8	21	27	160	36	8,040	0.80	908,063	●
63	10	24	32	160	40	10,050	0.90	910,063	●
63	12	24	32	160	45	12,100	0.90	112,063	●
63	14	27	34	160	45	14,100	1.00	114,063	●
63	16	27	34	160	48	16,100	1.00	116,063	●
63	18	33	42	160	48	18,100	1.20	118,063	●
63	20	33	42	160	50	20,100	1.20	120,063	●
63	25	44	53	160	56	25,100	1.80	125,063	●
63	32	44	53	160	60	32,100	1.70	132,063	●

Product information

- to Guhring MQL standard
- for 1-channel-systems
- balancing quality: G6.3 / 15,000 rev./min
- incl. balancing thread 4xM6/6xM6
- for tool shank tolerance h6
- max. deviation f. concentricity 3 µm
- also available in the lengths l₁ = 120 mm and 160 mm (concentricity 5 µm)

Scope of delivery

- incl. MQL adjustment screw with sealing lip Guhring no. 4937 and MQL coolant delivery set Guhring no. 4939
- special dimensions on request

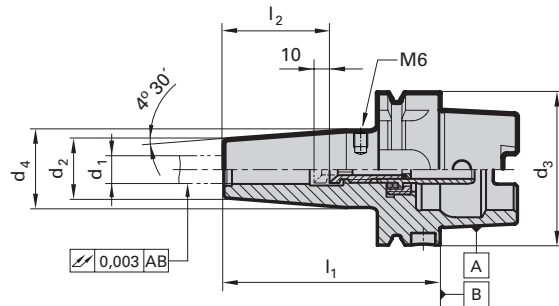

Guhring no. **4741**

Discount group **148**

HSK-A d ₃	for shank Ø d ₁ h6 mm	d ₂ mm	d ₄ mm	l ₁ mm	l ₂ mm	incl. setting screw no. 4937 ...	kg	Code no.	Availability
40	6	21	27	80	36	6,040	0.40	6,040	●
40	8	21	27	80	36	8,040	0.40	8,040	●
40	10	24	32	80	40	10,040	0.50	10,040	●
40	12	24	32	90	45	12,040	0.50	12,040	●
40	14	27	34	90	45	14,040	0.60	14,040	●
40	16	27	34	90	48	16,040	0.50	16,040	●
50	6	21	27	80	36	6,050	0.60	6,050	●
50	8	21	27	80	36	8,050	0.60	8,050	●
50	10	24	32	85	40	10,050	0.70	10,050	●
50	12	24	32	90	45	12,050	0.70	12,050	●
50	14	27	34	90	45	14,050	0.70	14,050	●
50	16	27	34	95	48	16,050	0.70	16,050	●
50	18	33	42	95	48	18,050	0.90	18,050	●
50	20	33	42	100	50	20,050	0.90	20,050	●
63	6	21	27	80	36	6,100	0.70	6,063	●
63	8	21	27	80	36	8,100	0.70	8,063	●
63	10	24	32	85	40	10,100	0.70	10,063	●
63	12	24	32	90	45	12,100	0.80	12,063	●
63	14	27	34	90	45	14,100	0.80	14,063	●
63	16	27	34	95	48	16,100	0.90	16,063	●
63	18	33	42	95	48	18,100	0.90	18,063	●
63	20	33	42	100	50	20,100	1.00	20,063	●
63	25	44	53	115	56	25,100	1.00	25,063	●
63	32	44	53	120	60	32,100	1.10	32,063	●
63	6	21	27	120	36	6,032	0.90	806,063	●
63	8	21	27	120	36	8,040	1.00	808,063	●
63	10	24	32	120	40	10,050	1.10	810,063	●
63	12	24	32	120	45	12,100	1.20	212,063	●
63	14	27	34	120	45	14,100	1.40	214,063	●
63	16	27	34	120	48	16,100	1.40	216,063	●
63	18	33	42	120	48	18,100	1.60	218,063	●
63	20	33	42	120	50	20,100	1.60	220,063	●
63	6	21	27	160	36	6,032	0.80	906,063	●
63	8	21	27	160	36	8,040	0.80	908,063	●
63	10	24	32	160	40	10,050	0.90	910,063	●
63	12	24	32	160	45	12,100	0.90	112,063	●
63	14	27	34	160	45	14,100	1.00	114,063	●
63	16	27	34	160	48	16,100	1.00	116,063	●
63	18	33	42	160	48	18,100	1.20	118,063	●
63	20	33	42	160	50	20,100	1.20	120,063	●
63	25	44	53	160	56	25,100	1.80	125,063	●
63	32	44	53	160	60	32,100	1.70	132,063	●

MQL 1-channel length setting screws for HSK-A

Product information

- to Guhring MQL standard
- for 1-channel-systems
- for the use of tool shanks to Guhring MQL standard
- gold colour, corrosion protective coating to visually identify the 1-channel system
- the patented face orientated o-ring provides axial force clamping which eliminates concentricity errors

Scope of delivery

- incl. sealing lip
- MQL key tool for the assembly Guhring no. 4050 to be ordered separately

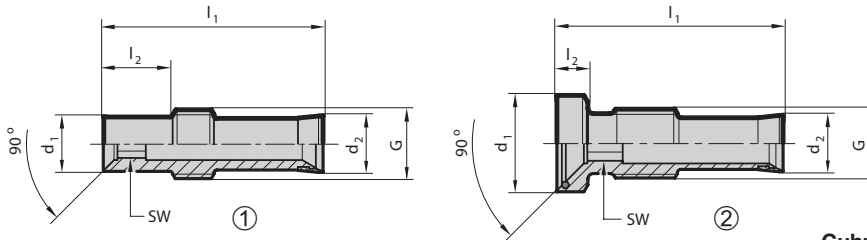

Guhring no. 4937

Discount group 114

HSK-A	for shank Ø d1 h6 mm	for d2 mm	l1 mm	l2 mm	G	SW	picture	Code no.	Availability
32	6	4.0	34.7	2.5	M5x0.8	2	2	6,032	●
32	8	4.0	34.7	3.0	M7x1	2	2	8,032	●
32	10	4.0	35.7	3.5	M8x1	2	2	10,032	●
32	12	4.0	35.7	3.5	M10x1	2	2	12,032	●
40	6	5.4	34.3	11.0	M7x1	3	1	6,040	●
40	8	5.4	34.3	3.0	M7x1	3	2	8,040	●
40	10	5.4	30.3	3.5	M8x1	3	2	10,040	●
40	12	5.4	35.3	3.5	M10x1	3	2	12,040	●
40	14	5.4	35.3	4.5	M10x1	3	2	14,040	●
40	16	5.4	32.3	5.5	M12x1	3	2	16,040	●
50	6	6.5	32.0	10.0	M8x1	4	1	6,050	●
50	8	6.5	32.0	3.0	M8x1	4	2	8,050	●
50	10	6.5	33.0	3.5	M8x1	4	2	10,050	●
50	12	6.5	33.0	3.5	M10x1	4	2	12,050	●
50	14	6.5	33.0	4.5	M10x1	4	2	14,050	●
50	16	6.5	35.0	5.5	M12x1	4	2	16,050	●
50	18	6.5	35.0	6.5	M12x1	4	2	18,050	●
50	20	6.5	38.0	6.5	M16x1	4	2	20,050	●
63/80/100	6	8.0	31.0	10.0	M10x1	4	1	6,100	●
63/80/100	8	8.0	31.8	10.0	M10x1	4	1	8,100	●
63/80/100	10	8.0	32.8	3.5	M10x1	4	2	10,100	●
63/80/100	12	8.0	32.8	3.5	M10x1	5	2	12,100	●
63/80/100	14	8.0	32.8	4.5	M10x1	5	2	14,100	●
63/80/100	16	8.0	34.8	5.5	M12x1	5	2	16,100	●
63/80/100	18	8.0	34.8	6.5	M12x1	5	2	18,100	●
63/80/100	20	8.0	37.8	6.5	M16x1	5	2	20,100	●
63/80/100	25	8.0	43.8	10.0	M16x1	5	2	25,100	●
63/80/100	32	8.0	44.8	14.0	M16x1	5	2	32,100	●

Sealing lips for MQL 1-channel length setting screws

Product information

- sealing lips for MQL 1-channel length setting screws Guhring no. 4937

Scope of delivery

- packaging unit: 5 pieces

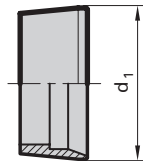

		Guhring no.	4617	
		Discount group	114	
HSK-A	d ₁ mm	Code no.	Availability	
32	4.0	1,032	●	
40	5.6	1,040	●	
50	6.7	1,050	●	
63 / 80 / 100	8.2	1,100	●	

MQL-Key 3000

Product information

- special tool set for the secure assembly of MQL tapered screws for 1- and 2-channel systems
- simplifies the handling when assembling the MQL length setting screws
- prevents damage to the MQL sealing elements
- i.e. to be applied for:
MQL 1-channel length setting screws Guhring no. 4937 or MQL 2-channel length setting screws Guhring no. 4621

Scope of delivery

- complete set in case or additional set



		Guhring no.	4050	
		Discount group	Net price	
		Code no.	Availability	
Case with complete 1- channel basis set		1,000	●	
2-channel additional set		2,000	●	

MQL 1-channel coolant delivery set HSK-A (filler)

Product information

- to Guhring MQL standard
- for 1-channel-systems
- for tool holders with manual tool change
- optimal seal for MQL clamping set

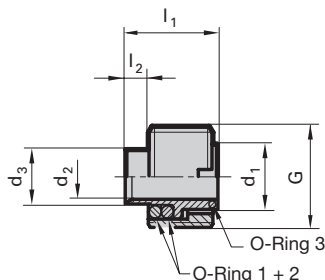

Guhring no. 4940

Discount group 114

for HSK-A	d ₁ mm	d ₂ mm	d ₃ mm	l ₁ mm	l ₂ mm	G	O-ring 1 & 2 Viton 75	O-ring 3 Viton 80	Code no.	Availability
32*	5.8	4.0	4.8	18.7	12.5	M10x1	5x1.2	4.3x0.5	10,032	●
40	7.6	5.4	6.8	13.8	5.5	M12x1.0	7.5x1.5	6x0.7	12,040	●
50	9.6	6.5	7.8	15.8	5.5	M16x1.0	9.0x2.0	7.5x0.8	16,050	●
63	11.6	8.0	9.7	16.3	4.0	M18x1.0	10x2.5	9x1	18,063	●
80	13.6	8.0	9.7	18.4	4.0	M20x1.5	13.0x2.0	9.5x1.5	20,080	●
100	15.6	8.0	11.7	18.4	2.0	M24x1.5	14.0x3.0	11.5x1.5	24,100	●

* for HSK extensions Guhring no. 4350

MQL 1-channel coolant delivery set HSK-A

Product information

- to Guhring MQL standard
- for 1-channel-systems
- for tool holders with automatic tool change

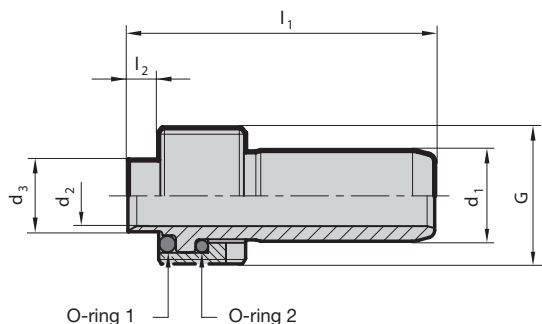

Guhring no. 4939

Discount group 114

for HSK-A	d ₁ mm	d ₂ mm	d ₃ mm	l ₁ mm	l ₂ mm	G	O-ring 1 Viton 75	O-ring 2 Viton 75	Code no.	Availability
32	6	4.0	4.8	38.5	12.5	M10x1.0	5x1.2	5x1.2	10,032	●
40	8	5.4	6.5	35.0	5.5	M12x1.0	7.5x1.5	7.5x1.5	12,040	●
50	10	6.5	7.5	38.5	5.5	M16x1.0	9.0x2.0	9.0x2.0	16,050	●
63	12	8.0	9.5	40.5	4.0	M18x1.0	10.0x2.5	10.0x2.0	18,063	●
80	14	8.0	9.7	44.0	4.0	M20x1.5	13.0x2.0	13.0x2.0	20,080	●
100	16	8.0	11.5	46.0	2.0	M24x1.5	14.0x3.0	14.0x3.0	24,100	●

Mounting adaptor for MQL HSK-A coolant delivery set (filler)

Product information

- adaptor for socket spanner, Guhring no. 4911
- for mounting MQL HSK-A coolant delivery set (filler), Guhring no. 4940, for manual tool change

Scope of delivery

- incl. operating manual
- socket spanner, Guhring no. 4911 to be ordered separately

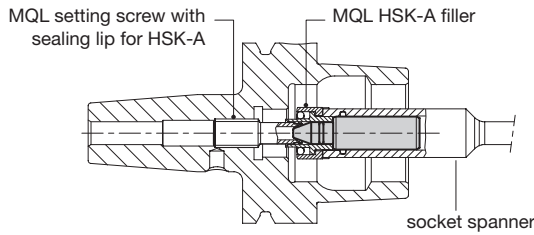
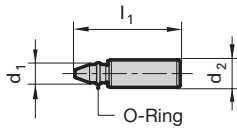

Guhring no.	4948
Discount group	114

for HSK-A	d ₁ mm	d ₂ mm	l ₁ mm	Code no.	Availability
40	5.4	8	38.5	8,040	●
50	6.5	10	42.0	10,050	●
63	8.0	12	46.0	12,063	●
80	8.0	14	48.5	14,080	●
100	8.0	16	51.5	16,100	●

HSK-A/HSK-C extensions with MQL 4 point clamping set

Product information

- MQL suitable
- for 1-channel-systems

Scope of delivery

- incl. MQL 4 point clamping set Guhring no. 4930 and adaptor for extensions
- incl. brass locking ring Guhring no. 4953
- order coolant delivery set separately:
 - for automatic tool change Guhring no. 4939
 - for manual tool change Guhring no. 4940

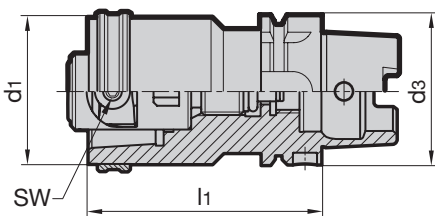

Guhring no.	4350
Discount group	114

HSK-A/HSK-C d ₁ / d ₃	l ₁ mm	SW	kg	Code no.	Availability
32	60	2.5	0.30	60,032	●
40	80	3.0	0.70	80,040	●
50	80	4.0	0.90	80,050	●
50	100	4.0	1.10	100,050	●
63	100	5.0	1.80	100,063	●
63	140	5.0	2.30	140,063	●
80	120	6.0	4.20	120,080	●
80	160	6.0	5.80	160,080	●
100	140	8.0	8.00	140,100	●

MQL HSK-A synchro tapping chucks for manual tool change

Product information

- for MQL single and double channel systems
- compensate synchronisation errors
- minimal length compensation in tension and compression direction balances very small pitch differences between synchro spindle and tap, which can cause high frictional forces on the thread flanks and increase thread quality and tool life
- length-setting screw allows 2 to 3 mm readjustment
- MQL pressure up to max. 10 bar
- mounted MQL coolant supply pipe
- Guhring MQL identifiable by green coloured ring

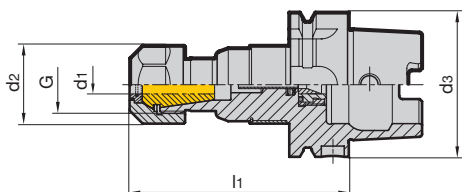

Scope of delivery

- incl. MQL coolant delivery set for manual tool change (filler)
- Incl. sealed IC/ER clamping nut Guhring no. 4306 (*see torque)
- incl. adjustment key for MQL adjustment screw
- order MQL adjustment screw Guhring no. 4305 separately
- order sealing washer Guhring no. 4335 separately
- order collet Guhring no. 4308 separately
- order chuck spanner Guhring no. 4913 for ER retaining nut separately



Guhring no. 4298

Discount group 114

HSK-A d ₃	nom. size	for thread	G	d ₁ mm	d ₂ mm	l ₁ mm	tension/compr. ± mm	torque* Nm	kg	Code no.	Availability
63	ER20	M3.5-M14	M25x1.5	4.5-11	34	95.5	0.15	40	1.00	20,063	●
63	ER32	M3.5-M28	M40x1.5	4.5-20	50	109.0	0.15	170	1.50	32,063	●

MQL HSK-A synchro tapping chucks for single channel systems for automatic tool change

Product information

- for MQL single channel systems
- compensate synchronisation errors
- minimal length compensation in tension and compression direction balances very small pitch differences between synchro spindle and tap, which can cause high frictional forces on the thread flanks and increase thread quality and tool life
- length-setting screw allows 2 to 3 mm readjustment
- MQL pressure up to max. 10 bar
- mounted MQL coolant supply pipe
- Guhring MQL identifiable by green coloured ring

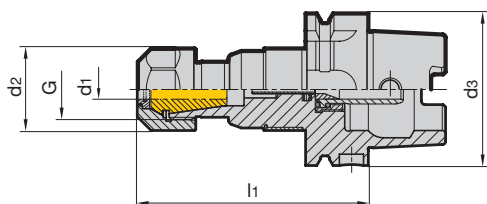

Scope of delivery

- incl. MQL coolant delivery set for automatic tool change
- Incl. sealed IC/ER clamping nut Guhring no. 4306 (*see torque)
- incl. adjustment key for MQL adjustment screw
- order MQL adjustment screw Guhring no. 4305 separately
- order sealing washer Guhring no. 4335 separately
- order collet Guhring no. 4308 separately
- order chuck spanner Guhring no. 4913 for ER retaining nut separately



Guhring no. 4330

Discount group 114

HSK-A d ₃	nom. size	for thread	G	d ₁ mm	d ₂ mm	l ₁ mm	tension/compr. ± mm	torque* Nm	kg	Code no.	Availability
63	ER20	M3.5-M14	M25x1.5	4.5-11	34	95.5	0.15	40	1.00	20,063	●
63	ER32	M3.5-M28	M40x1.5	4.5-20	50	109.0	0.15	170	1.50	32,063	●
100	ER20	M3.5-M14	M25x1.5	4.5-11	34	102.0	0.15	40	2.40	20,100	●
100	ER32	M3.5-M28	M40x1.5	4.5-20	50	115.5	0.15	170	3.00	32,100	●



Our products for the MQL 2-channel technology are identified by this symbol.

Visual feature of the 2-channel system is the black coloured MQL length setting screw.

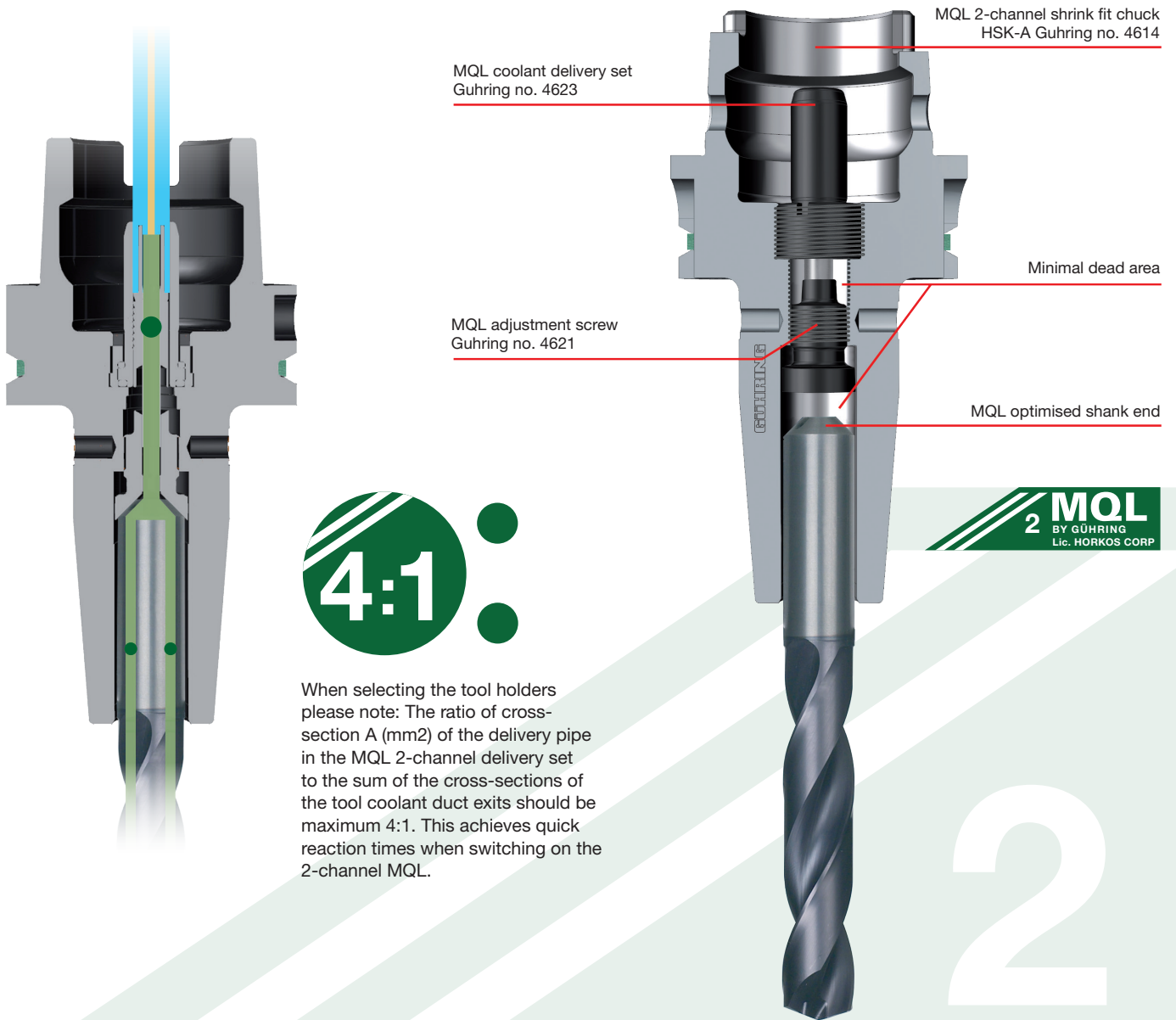

4:1

When selecting the tool holders please note: The ratio of cross-section A (mm²) of the delivery pipe in the MQL 2-channel delivery set to the sum of the cross-sections of the tool coolant duct exits should be maximum 4:1. This achieves quick reaction times when switching on the 2-channel MQL.



MQL 2-channel hydraulic chucks HSK-A for manual tool change

Product information

- to Guhring MQL standard
- for 2-channel-systems
- balancing quality: G6.3 / 15,000 rev./min
- for tool shank tolerance h6
- also available in the lengths $l_1 = 120$ mm and 160 mm (concentricity $5 \mu\text{m}$)
- axial length setting

Scope of delivery

- incl. MQL adjustment screw Guhring no. 4621 and MQL coolant delivery set Guhring no. 4622
- incl. hexagon chuck key Guhring no. 4912
- special dimensions on request

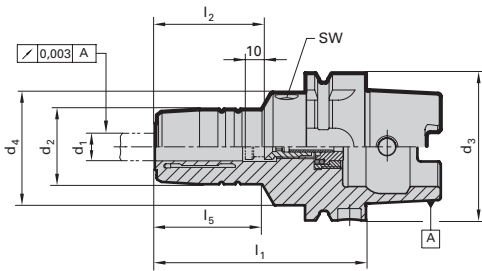

Guhring no. **4611**

Discount group **147**

HSK-A d ₃	for shank Ø d ₁ h ₆ mm	A mm ²	d ₂ mm	d ₄ mm	l ₁ mm	l ₂ mm	l ₅ mm	incl. setting screw no. 4621 ...	incl. filler no. 4622 ...	SW	kg	4:1	
												Code no.	Availability
50	6	2.01	26	40	80	36	38	6.050	10.050	4	0.95	6,050	●
50	6	4.15	26	40	80	36	38	6.150	10.150	4	0.95	6,150	●
50	8	2.01	28	40	80	36	38	8.050	10.050	4	0.95	8,050	●
50	8	4.15	28	40	80	36	38	8.150	10.150	4	0.95	8,150	●
50	10	2.01	30	40	85	40	44	10.050	10.050	4	0.95	10,050	●
50	10	4.15	30	40	85	40	44	10.150	10.150	4	0.95	10,150	●
50	12	2.01	32	40	90	45	49	12.050	18.050	4	0.95	12,050	●
50	12	4.15	32	40	90	45	49	12.150	20.050	4	0.95	12,150	●
50	12	9.08	32	40	90	45	49	12.250	20.150	4	0.95	12,250	●
50	14	2.01	34	40	90	45	49	14.050	18.050	4	0.95	14,050	●
50	14	4.15	34	40	90	45	49	14.150	20.050	4	0.95	14,150	●
50	14	9.08	34	40	90	45	49	14.250	20.150	4	0.95	14,250	●
50	16	2.01	38	53	95	48	36	16.050	18.050	5	1.25	16,050	●
50	16	4.15	38	53	95	48	36	16.150	20.050	5	1.25	16,150	●
50	16	9.08	38	53	95	48	36	16.250	20.150	5	1.25	16,250	●
50	18	2.01	40	57	95	48	36	18.050	18.050	5	1.25	18,050	●
50	18	4.15	40	57	95	48	36	18.150	20.050	5	1.25	18,150	●
50	18	9.08	40	57	95	48	36	18.250	20.150	5	1.25	18,250	●
50	20	4.15	42	60	100	50	39	20.050	20.050	5	1.25	20,050	●
50	20	9.08	42	60	100	50	39	20.150	20.150	5	1.25	20,150	●
50	20	16.62	42	60	100	50	39	20.250	20.250	5	1.25	20,250	●
63	6	2.01	26	50	80	36	34.5	6.100	10.063	5	1.25	6,063	●
63	6	4.15	26	50	80	36	34.5	6.101	10.163	5	1.25	6,163	●
63	8	2.01	28	50	80	36	35.5	8.100	10.063	5	1.25	8,063	●
63	8	4.15	28	50	80	36	35.5	8.101	10.163	5	1.25	8,163	●
63	10	2.01	30	50	85	40	40	10.100	10.063	5	1.25	10,063	●
63	10	4.15	30	50	85	40	40	10.101	10.163	5	1.25	10,163	●
63	12	2.01	32	50	90	45	45	12.100	18.063	5	1.35	12,063	●
63	12	4.15	32	50	90	45	45	12.101	20.063	5	1.35	12,163	●
63	12	9.08	32	50	90	45	45	12.102	20.163	5	1.35	12,263	●
63	14	2.01	34	50	90	45	46	14.100	18.063	5	1.35	14,063	●
63	14	4.15	34	50	90	45	46	14.101	20.063	5	1.35	14,163	●
63	14	9.08	34	50	90	45	46	14.102	20.163	5	1.35	14,263	●
63	16	2.01	38	50	95	48	51	16.100	18.063	5	1.45	16,063	●
63	16	4.15	38	50	95	48	51	16.101	20.063	5	1.45	16,163	●
63	16	9.08	38	50	95	48	51	16.102	20.163	5	1.45	16,263	●
63	18	2.01	40	50	95	48	52	18.100	18.063	5	1.45	18,063	●
63	18	4.15	40	50	95	48	52	18.101	20.063	5	1.45	18,163	●
63	18	9.08	40	50	95	48	52	18.102	20.163	5	1.45	18,263	●
63	20	4.15	42	50	100	50	58	20.100	20.063	5	1.45	20,063	●
63	20	9.08	42	50	100	50	58	20.101	20.163	5	1.45	20,163	●
63	20	16.62	42	50	100	50	58	20.102	20.263	5	1.45	20,263	●
63	25	4.15	57	63	115	56	50	25.100	32.063	6	2.45	25,063	●
63	25	9.08	57	63	115	56	50	25.101	32.163	6	2.45	25,163	●
63	25	16.62	57	63	115	56	50	25.102	32.263	6	2.45	25,263	●
63	32	4.15	64	75	120	60	58	32.100	32.063	6	3.10	32,063	●

MQL 2-channel hydraulic chucks HSK-A for manual tool change

												Guhring no. 4611	
												Discount group 147	
HSK-A d ₃	for shank Ø d ₁ h ₆ mm	A mm ²	d ₂ mm	d ₄ mm	l ₁ mm	l ₂ mm	l ₅ mm	incl. setting screw no. 4621 ...	incl. filler no. 4622 ...	SW	kg	Code no.	Availability
63	32	9.08	64	75	120	60	58	32.101	32.163	6	3.10	32,163	●
63	32	16.62	64	75	120	60	58	32.102	32.263	6	3.10	32,263	●
100	6	2.01	26	50	85	36	36	6.100	10.100	5	2.60	6,100	●
100	6	4.15	26	50	85	36	36	6.101	10.101	5	2.60	6,101	●
100	8	2.01	28	50	85	36	36	8.100	10.100	5	2.60	8,100	●
100	8	4.15	28	50	85	36	36	8.101	10.101	5	2.60	8,101	●
100	10	2.01	30	50	90	40	42	10.100	10.100	5	2.60	10,100	●
100	10	4.15	30	50	90	40	42	10.101	10.101	5	2.60	10,101	●
100	12	2.01	32	50	95	45	47	12.100	18.100	5	2.65	12,100	●
100	12	4.15	32	50	95	45	47	12.101	32.100	5	2.65	12,101	●
100	12	9.08	32	50	95	45	47	12.102	32.101	5	2.65	12,102	●
100	14	2.01	34	50	95	45	47	14.100	18.100	5	2.65	14,100	●
100	14	4.15	34	50	95	45	47	14.101	32.100	5	2.65	14,101	●
100	14	9.08	34	50	95	45	47	14.102	32.101	5	2.65	14,102	●
100	16	2.01	38	50	100	48	53	16.100	18.100	5	2.85	16,100	●
100	16	4.15	38	50	100	48	53	16.101	32.100	5	2.85	16,101	●
100	16	9.08	38	50	100	48	53	16.102	32.101	5	2.85	16,102	●
100	18	2.01	40	50	100	48	53	18.100	18.100	5	2.85	18,100	●
100	18	4.15	40	50	100	48	53	18.101	32.100	5	2.85	18,101	●
100	18	9.08	40	50	100	48	53	18.102	32.101	5	2.85	18,102	●
100	20	4.15	42	50	105	50	59	20.100	32.100	5	3.35	20,100	●
100	20	9.08	42	50	105	50	59	20.101	32.101	5	3.35	20,101	●
100	20	16.62	42	50	105	50	59	20.102	32.102	5	3.35	20,102	●
100	25	4.15	57	63	115	56	67	25.100	32.100	6	3.50	25,100	●
100	25	9.08	57	63	115	56	67	25.101	32.101	6	3.50	25,101	●
100	25	16.62	57	63	115	56	67	25.102	32.102	6	3.50	25,102	●
100	32	4.15	64	75	120	60	72	32.100	32.100	6	3.95	32,100	●
100	32	9.08	64	75	120	60	72	32.101	32.101	6	3.95	32,101	●
100	32	16.62	64	75	120	60	72	32.102	32.102	6	3.95	32,102	●

MQL 2-channel hydraulic chucks HSK-A for automatic tool change

Product information

- to Guhring MQL standard
- for 2-channel-systems
- balancing quality: G6.3 / 15,000 rev./min
- for tool shank tolerance h6
- axial length setting

Scope of delivery

- incl. MQL adjustment screw with sealing lip Guhring no. 4621 and MQL coolant delivery set Guhring no. 4623
- incl. hexagon chuck key Guhring no. 4912
- special dimensions on request

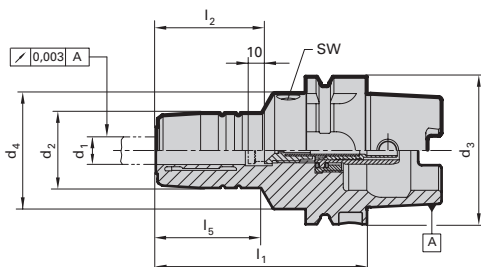

												Guhring no. 4612	
												Discount group 147	
HSK-A d ₃	for shank Ø d ₁ h ₆ mm	A mm ²	d ₂ mm	d ₄ mm	l ₁ mm	l ₂ mm	l ₅ mm	incl. setting screw no. 4621 ...	incl. filler no. 4623 ...	SW	kg	Code no.	Availability
50	6	2.01	26	40	80	36	38	6.050	10.050	4	0.95	6,050	●
50	6	4.15	26	40	80	36	38	6.150	10.150	4	0.95	6,150	●
50	8	2.01	28	40	80	36	38	8.050	10.050	4	0.95	8,050	●
50	8	4.15	28	40	80	36	38	8.150	10.150	4	0.95	8,150	●
50	10	2.01	30	40	85	40	44	10.050	10.050	4	0.95	10,050	●
50	10	4.15	30	40	85	40	44	10.150	10.150	4	0.95	10,150	●
50	12	2.01	32	40	90	45	49	12.050	18.050	4	0.95	12,050	●

MQL 2-channel hydraulic chucks HSK-A for automatic tool change

												Guhring no. 4612	
												Discount group 147	
HSK-A d ₃	for shank Ø d ₁ h ₆ mm	4:1 A mm ²	d ₂ mm	d ₄ mm	l ₁ mm	l ₂ mm	l ₅ mm	incl. setting screw no. 4621 ...	incl. filler no. 4623 ...	SW	kg	Code no.	Availability
50	12	4.15	32	40	90	45	49	12.150	20.050	4	0.95	12,150	●
50	12	9.08	32	40	90	45	49	12.250	20.150	4	0.95	12,250	●
50	14	2.01	34	40	90	45	49	14.050	18.050	4	0.95	14,050	●
50	14	4.15	34	40	90	45	49	14.150	20.050	4	0.95	14,150	●
50	14	9.08	34	40	90	45	49	14.250	20.150	4	0.95	14,250	●
50	16	2.01	38	53	95	48	36	16.050	18.050	5	1.25	16,050	●
50	16	4.15	38	53	95	48	36	16.150	20.050	5	1.25	16,150	●
50	16	9.08	38	53	95	48	36	16.250	20.150	5	1.25	16,250	●
50	18	2.01	40	57	95	48	36	18.050	18.050	5	1.25	18,050	●
50	18	4.15	40	57	95	48	36	18.150	20.050	5	1.25	18,150	●
50	18	9.08	40	57	95	48	36	18.250	20.150	5	1.25	18,250	●
50	20	4.15	42	60	100	50	39	20.050	20.050	5	1.25	20,050	●
50	20	9.08	42	60	100	50	39	20.150	20.150	5	1.25	20,150	●
50	20	16.62	42	60	100	50	39	20.250	20.250	5	1.25	20,250	●
63	6	2.01	26	50	80	36	34.5	6.100	10.063	5	1.25	6,063	●
63	6	4.15	26	50	80	36	34.5	6.101	10.163	5	1.25	6,163	●
63	8	2.01	28	50	80	36	35.5	8.100	10.063	5	1.25	8,063	●
63	8	4.15	28	50	80	36	35.5	8.101	10.163	5	1.25	8,163	●
63	10	2.01	30	50	85	40	40	10.100	10.063	5	1.25	10,063	●
63	10	4.15	30	50	85	40	40	10.101	10.163	5	1.25	10,163	●
63	12	2.01	32	50	90	45	45	12.100	18.063	5	1.35	12,063	●
63	12	4.15	32	50	90	45	45	12.101	20.063	5	1.35	12,163	●
63	12	9.08	32	50	90	45	45	12.102	20.163	5	1.35	12,263	●
63	14	2.01	34	50	90	45	46	14.100	18.063	5	1.35	14,063	●
63	14	4.15	34	50	90	45	46	14.101	20.063	5	1.35	14,163	●
63	14	9.08	34	50	90	45	46	14.102	20.163	5	1.35	14,263	●
63	16	2.01	38	50	95	48	51	16.100	18.063	5	1.45	16,063	●
63	16	4.15	38	50	95	48	51	16.101	20.063	5	1.45	16,163	●
63	16	9.08	38	50	95	48	51	16.102	20.163	5	1.45	16,263	●
63	18	2.01	40	50	95	48	52	18.100	18.063	5	1.45	18,063	●
63	18	4.15	40	50	95	48	52	18.101	20.063	5	1.45	18,163	●
63	18	9.08	40	50	95	48	52	18.102	20.163	5	1.45	18,263	●
63	20	4.15	42	50	100	50	58	20.100	20.063	5	1.45	20,063	●
63	20	9.08	42	50	100	50	58	20.101	20.163	5	1.45	20,163	●
63	20	16.62	42	50	100	50	58	20.102	20.263	5	1.45	20,263	●
63	25	4.15	57	63	115	56	50	25.100	32.063	6	2.45	25,063	●
63	25	9.08	57	63	115	56	50	25.101	32.163	6	2.45	25,163	●
63	25	16.62	57	63	115	56	50	25.102	32.263	6	2.45	25,263	●
63	32	4.15	64	75	120	60	58	32.100	32.063	6	3.10	32,063	●
63	32	9.08	64	75	120	60	58	32.101	32.163	6	3.10	32,163	●
63	32	16.62	64	75	120	60	58	32.102	32.263	6	3.10	32,263	●
100	6	2.01	26	50	85	36	36	6.100	10.100	5	2.60	6,100	●
100	6	4.15	26	50	85	36	36	6.101	10.101	5	2.60	6,101	●
100	8	2.01	28	50	85	36	36	8.100	10.100	5	2.60	8,100	●
100	8	4.15	28	50	85	36	36	8.101	10.101	5	2.60	8,101	●
100	10	2.01	30	50	90	40	42	10.100	10.100	5	2.60	10,100	●
100	10	4.15	30	50	90	40	42	10.101	10.101	5	2.60	10,101	●
100	12	2.01	32	50	95	45	47	12.100	18.100	5	2.65	12,100	●
100	12	4.15	32	50	95	45	47	12.101	32.100	5	2.65	12,101	●
100	12	9.08	32	50	95	45	47	12.102	32.101	5	2.65	12,102	●
100	14	2.01	34	50	95	45	47	14.100	18.100	5	2.65	14,100	●
100	14	4.15	34	50	95	45	47	14.101	32.100	5	2.65	14,101	●
100	14	9.08	34	50	95	45	47	14.102	32.101	5	2.65	14,102	●
100	16	2.01	38	50	100	48	53	16.100	18.100	5	2.85	16,100	●
100	16	4.15	38	50	100	48	53	16.101	32.100	5	2.85	16,101	●
100	16	9.08	38	50	100	48	53	16.102	32.101	5	2.85	16,102	●
100	18	2.01	40	50	100	48	53	18.100	18.100	5	2.85	18,100	●
100	18	4.15	40	50	100	48	53	18.101	32.100	5	2.85	18,101	●
100	18	9.08	40	50	100	48	53	18.102	32.101	5	2.85	18,102	●
100	20	4.15	42	50	105	50	59	20.100	32.100	5	3.35	20,100	●
100	20	9.08	42	50	105	50	59	20.101	32.101	5	3.35	20,101	●
100	20	16.62	42	50	105	50	59	20.102	32.102	5	3.35	20,102	●
100	25	4.15	57	63	115	56	67	25.100	32.100	6	3.50	25,100	●
100	25	9.08	57	63	115	56	67	25.101	32.101	6	3.50	25,101	●
100	25	16.62	57	63	115	56	67	25.102	32.102	6	3.50	25,102	●
100	32	4.15	64	75	120	60	72	32.100	32.100	6	3.95	32,100	●
100	32	9.08	64	75	120	60	72	32.101	32.101	6	3.95	32,101	●
100	32	16.62	64	75	120	60	72	32.102	32.102	6	3.95	32,102	●

MQL 2-channel shrink fit chucks HSK-A for manual tool change

Product information

- to Guhring MQL standard
- for 2-channel-systems
- balancing quality: G6.3 / 15,000 rev./min
- incl. balancing thread 4xM6/6xM6
- for tool shank tolerance h6
- also available in the lengths l1 = 120 mm and 160 mm (concentricity 5 µm)

Scope of delivery

- incl. MQL adjustment screw Guhring no. 4621 and MQL coolant delivery set Guhring no. 4622
- special dimensions on request

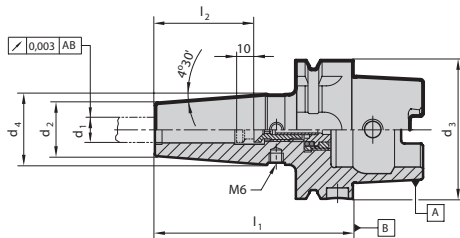

Guhring no. **4613**

Discount group **148**

HSK-A d3	for shank Ø d1 h6 mm	A mm ²	d2 mm	d4 mm	l1 mm	l2 mm	incl. setting screw no. 4621 ...	incl. filler no. 4622 ...	kg	4:1	
										Code no.	Availability
40	6	2.01	21	27	80	36	6.040	16.040	0.40	6,040	●
40	6	4.15	21	27	80	36	6.140	16.140	0.40	6,140	●
40	8	2.01	21	27	80	36	8.040	16.040	0.40	8,040	●
40	8	4.15	21	27	80	36	8.140	16.140	0.40	8,140	●
40	10	2.01	24	32	80	40	10.040	16.040	0.50	10,040	●
40	10	4.15	24	32	80	40	10.140	16.140	0.50	10,140	●
40	12	2.01	24	32	90	45	12.040	16.040	0.50	12,040	●
40	12	4.15	24	32	90	45	12.140	16.140	0.50	12,140	●
40	12	9.08	24	32	90	45	12.240	16.240	0.50	12,240	●
40	14	2.01	27	34	90	45	14.040	16.040	0.60	14,040	●
40	14	4.15	27	34	90	45	14.140	16.140	0.60	14,140	●
40	14	9.08	27	34	90	45	14.240	16.240	0.60	14,240	●
40	16	2.01	27	34	90	48	16.040	16.040	0.50	16,040	●
40	16	4.15	27	34	90	48	16.140	16.140	0.50	16,140	●
40	16	9.08	27	34	90	48	16.240	16.240	0.50	16,240	●
50	6	2.01	21	27	80	36	6.050	10.050	0.60	6,050	●
50	6	4.15	21	27	80	36	6.150	10.150	0.60	6,150	●
50	8	2.01	21	27	80	36	8.050	10.050	0.60	8,050	●
50	8	4.15	21	27	80	36	8.150	10.150	0.60	8,150	●
50	10	2.01	24	32	85	40	10.050	10.050	0.70	10,050	●
50	10	4.15	24	32	85	40	10.150	10.150	0.70	10,150	●
50	12	2.01	24	32	90	45	12.050	18.050	0.70	12,050	●
50	12	4.15	24	32	90	45	12.150	20.050	0.70	12,150	●
50	12	9.08	24	32	90	45	12.250	20.150	0.70	12,250	●
50	14	2.01	27	34	90	45	14.050	18.050	0.70	14,050	●
50	14	4.15	27	34	90	45	14.150	20.050	0.70	14,150	●
50	14	9.08	27	34	90	45	14.250	20.150	0.70	14,250	●
50	16	2.01	27	34	95	48	16.050	18.050	0.70	16,050	●
50	16	4.15	27	34	95	48	16.150	20.050	0.70	16,150	●
50	16	9.08	27	34	95	48	16.250	20.150	0.70	16,250	●
50	18	2.01	33	42	95	48	18.050	18.050	0.90	18,050	●
50	18	4.15	33	42	95	48	18.150	20.050	0.90	18,150	●
50	18	9.08	33	42	95	48	18.250	20.150	0.90	18,250	●
50	20	4.15	33	42	100	50	20.050	20.050	0.90	20,050	●
50	20	9.08	33	42	100	50	20.150	20.150	0.90	20,150	●
50	20	16.62	33	42	100	50	20.250	20.250	0.90	20,250	●
63	6	2.01	21	27	80	36	6.100	10.063	0.70	6,063	●
63	6	4.15	21	27	80	36	6.101	10.163	0.70	6,163	●
63	8	2.01	21	27	80	36	8.100	10.063	0.70	8,063	●
63	8	4.15	21	27	80	36	8.101	10.163	0.70	8,163	●
63	10	2.01	24	32	85	40	10.100	10.063	0.70	10,063	●
63	10	4.15	24	32	85	40	10.101	10.163	0.70	10,163	●
63	12	2.01	24	32	90	45	12.100	18.063	0.80	12,063	●
63	12	4.15	24	32	90	45	12.101	20.063	0.80	12,163	●
63	12	9.08	24	32	90	45	12.102	20.163	0.80	12,263	●
63	14	2.01	27	34	90	45	14.100	18.063	0.80	14,063	●
63	14	4.15	27	34	90	45	14.101	20.063	0.80	14,163	●

MQL 2-channel shrink fit chucks HSK-A for manual tool change

											Guhring no. 4613	
											Discount group 148	
HSK-A d ₃	for shank Ø d ₁ h ₆ mm	 A mm ²	d ₂ mm	d ₄ mm	l ₁ mm	l ₂ mm	incl. setting screw no. 4621 ...	incl. filler no. 4622 ...	kg	Code no.	Availability	
63	14	9.08	27	34	90	45	14.102	20.163	0.80	14,263	●	
63	16	2.01	27	34	95	48	16.100	18.063	0.90	16,063	●	
63	16	4.15	27	34	95	48	16.101	20.063	0.90	16,163	●	
63	16	9.08	27	34	95	48	16.102	20.163	0.90	16,263	●	
63	18	2.01	33	42	95	48	18.100	18.063	0.90	18,063	●	
63	18	4.15	33	42	95	48	18.101	20.063	0.90	18,163	●	
63	18	9.08	33	42	95	48	18.102	20.163	0.90	18,263	●	
63	20	4.15	33	42	100	50	20.100	20.063	1.00	20,063	●	
63	20	9.08	33	42	100	50	20.101	20.163	1.00	20,163	●	
63	20	16.62	33	42	100	50	20.102	20.263	1.00	20,263	●	
63	25	4.15	44	53	115	56	25.100	32.063	1.00	25,063	●	
63	25	9.08	44	53	115	56	25.101	32.163	1.00	25,163	●	
63	25	16.62	44	53	115	56	25.102	32.263	1.00	25,263	●	
63	32	4.15	44	53	120	60	32.100	32.063	1.10	32,063	●	
63	32	9.08	44	53	120	60	32.101	32.163	1.10	32,163	●	
63	32	16.62	44	53	120	60	32.102	32.263	1.10	32,263	●	
63	6	2.01	21	27	120	36	6.032	208.063	0.90	206,063	●	
63	6	4.15	21	27	120	36	6.132	208.163	0.90	206,163	●	
63	8	2.01	21	27	120	36	8.040	208.063	1.00	208,063	●	
63	8	4.15	21	27	120	36	8.140	208.163	1.00	208,163	●	
63	10	2.01	24	32	120	40	10.050	210.063	1.10	210,063	●	
63	10	4.15	24	32	120	40	10.150	210.063	1.10	210,163	●	
63	12	2.01	24	32	120	45	12.100	214.063	1.20	212,063	●	
63	12	4.15	24	32	120	45	12.101	214.163	1.20	212,163	●	
63	12	9.08	24	32	120	45	12.102	214.263	1.20	212,263	●	
63	14	2.01	27	34	120	45	14.100	214.063	1.20	214,063	●	
63	14	4.15	27	34	120	45	14.101	214.163	1.20	214,163	●	
63	14	9.08	27	34	120	45	14.102	214.263	1.20	214,263	●	
63	16	2.01	27	34	120	48	16.100	218.063	1.20	216,063	●	
63	16	4.15	27	34	120	48	16.101	218.163	1.20	216,163	●	
63	16	9.08	27	34	120	48	16.102	218.263	1.20	216,263	●	
63	18	2.01	33	42	120	48	18.100	218.063	1.40	218,063	●	
63	18	4.15	33	42	120	48	18.101	218.163	1.40	218,163	●	
63	18	9.08	33	42	120	48	18.102	218.263	1.40	218,263	●	
63	20	4.15	33	42	120	50	20.100	220.063	1.40	220,063	●	
63	20	9.08	33	42	120	50	20.101	220.163	1.40	220,163	●	
63	20	16.62	33	42	120	50	20.102	220.263	1.40	220,263	●	
63	6	2.01	21	27	160	36	6.032	108.063	0.80	106,063	●	
63	6	4.15	21	27	160	36	6.132	108.163	0.80	106,163	●	
63	8	2.01	21	27	160	36	8.040	108.063	0.80	108,063	●	
63	8	4.15	21	27	160	36	8.140	108.163	0.80	108,163	●	
63	10	2.01	24	32	160	40	10.050	110.063	0.90	110,063	●	
63	10	4.15	24	32	160	40	10.150	110.163	0.90	110,163	●	
63	12	2.01	24	32	160	45	12.100	114.063	0.90	112,063	●	
63	12	4.15	24	32	160	45	12.101	114.163	0.90	112,163	●	
63	12	9.08	24	32	160	45	12.102	114.263	0.90	112,263	●	
63	14	2.01	27	34	160	45	14.100	114.063	1.00	114,063	●	
63	14	4.15	27	34	160	45	14.101	114.163	1.00	114,163	●	
63	14	9.08	27	34	160	45	14.102	114.263	1.00	114,263	●	
63	16	2.01	27	34	160	48	16.100	118.063	1.00	116,063	●	
63	16	4.15	27	34	160	48	16.101	118.163	1.00	116,163	●	
63	16	9.08	27	34	160	48	16.102	118.263	1.00	116,263	●	
63	18	2.01	33	42	160	48	18.100	118.063	1.20	118,063	●	
63	18	4.15	33	42	160	48	18.101	118.163	1.20	118,163	●	
63	18	9.08	33	42	160	48	18.102	118.263	1.20	118,263	●	
63	20	4.15	33	42	160	50	20.100	120.063	1.20	120,063	●	
63	20	9.08	33	42	160	50	20.101	120.163	1.20	120,163	●	
63	20	16.62	33	42	160	50	20.102	120.263	1.20	120,263	●	
63	25	4.15	44	53	160	56	25.100	125.063	1.80	125,063	●	
63	25	9.08	44	53	160	56	25.101	125.163	1.80	125,163	●	
63	25	16.62	44	53	160	56	25.102	125.263	1.80	125,263	●	
63	32	4.15	44	53	160	60	32.100	132.063	1.70	132,063	●	
63	32	9.08	44	53	160	60	32.101	132.163	1.70	132,163	●	
63	32	16.62	44	53	160	60	32.102	132.263	1.70	132,263	●	
80	6	2.01	21	27	85	36	6.100	10.080	1.30	6,080	●	
80	6	4.15	21	27	85	36	6.101	10.180	1.30	6,180	●	
80	8	2.01	21	27	85	36	8.100	10.080	1.30	8,080	●	
80	8	4.15	21	27	85	36	8.101	10.180	1.30	8,180	●	

MQL 2-channel shrink fit chucks HSK-A for manual tool change

										Guhring no. 4613	
										Discount group 148	
HSK-A d ₃	for shank Ø d ₁ h ₆ mm	 A mm ²	d ₂ mm	d ₄ mm	l ₁ mm	l ₂ mm	incl. setting screw no. 4621 ...	incl. filler no. 4622 ...	kg	Code no.	Availability
80	10	2.01	24	32	90	40	10.100	10.080	1.40	10,080	●
80	10	4.15	24	32	90	40	10.101	10.180	1.40	10,180	●
80	12	2.01	24	32	95	45	12.100	18.080	1.40	12,080	●
80	12	4.15	24	32	95	45	12.101	32.080	1.40	12,180	●
80	12	9.08	24	32	95	45	12.102	32.180	1.40	12,280	●
80	14	2.01	27	34	95	45	14.100	18.080	1.50	14,080	●
80	14	4.15	27	34	95	45	14.101	32.080	1.50	14,180	●
80	14	9.08	27	34	95	45	14.102	32.180	1.50	14,280	●
80	16	2.01	27	34	100	48	16.100	18.080	1.50	16,080	●
80	16	4.15	27	34	100	48	16.101	32.080	1.50	16,180	●
80	16	9.08	27	34	100	48	16.102	32.180	1.50	16,280	●
80	18	2.01	33	42	100	48	18.100	18.080	1.70	18,080	●
80	18	4.15	33	42	100	48	18.101	32.080	1.70	18,180	●
80	18	9.08	33	42	100	48	18.102	32.180	1.70	18,280	●
80	20	4.15	33	42	105	50	20.100	32.080	1.70	20,080	●
80	20	9.08	33	42	105	50	20.101	32.180	1.70	20,180	●
80	20	16.62	33	42	105	50	20.102	32.280	1.70	20,280	●
80	25	4.15	44	53	115	56	25.100	32.080	2.20	25,080	●
80	25	9.08	44	53	115	56	25.101	32.180	2.20	25,180	●
80	25	16.62	44	53	115	56	25.102	32.280	2.20	25,280	●
80	32	4.15	44	53	120	60	32.100	32.080	2.10	32,080	●
80	32	9.08	44	53	120	60	32.101	32.180	2.10	32,180	●
80	32	16.62	44	53	120	60	32.102	32.280	2.10	32,280	●
100	6	2.01	21	27	85	36	6.100	10.100	2.10	6,100	●
100	6	4.15	21	27	85	36	6.101	10.101	2.10	6,101	●
100	8	2.01	21	27	85	36	8.100	10.100	2.20	8,100	●
100	8	4.15	21	27	85	36	8.101	10.101	2.20	8,101	●
100	10	2.01	24	32	90	40	10.100	10.100	2.30	10,100	●
100	10	4.15	24	32	90	40	10.101	10.101	2.30	10,101	●
100	12	2.01	24	32	95	45	12.100	18.100	2.30	12,100	●
100	12	4.15	24	32	95	45	12.101	32.100	2.30	12,101	●
100	12	9.08	24	32	95	45	12.102	32.101	2.30	12,102	●
100	14	2.01	27	34	95	45	14.100	18.100	2.30	14,100	●
100	14	4.15	27	34	95	45	14.101	32.100	2.30	14,101	●
100	14	9.08	27	34	95	45	14.102	32.101	2.30	14,102	●
100	16	2.01	27	34	100	48	16.100	18.100	2.30	16,100	●
100	16	4.15	27	34	100	48	16.101	32.100	2.30	16,101	●
100	16	9.08	27	34	100	48	16.102	32.101	2.30	16,102	●
100	18	2.01	33	42	100	48	18.100	18.100	2.50	18,100	●
100	18	4.15	33	42	100	48	18.101	32.100	2.50	18,101	●
100	18	9.08	33	42	100	48	18.102	32.101	2.50	18,102	●
100	20	4.15	33	42	105	50	20.100	32.100	2.50	20,100	●
100	20	9.08	33	42	105	50	20.101	32.101	2.50	20,101	●
100	20	16.62	33	42	105	50	20.102	32.102	2.50	20,102	●
100	25	4.15	44	53	115	56	25.100	32.100	3.00	25,100	●
100	25	9.08	44	53	115	56	25.101	32.101	3.00	25,101	●
100	25	16.62	44	53	115	56	25.102	32.102	3.00	25,102	●
100	32	4.15	44	53	120	60	32.100	32.100	3.00	32,100	●
100	32	9.08	44	53	120	60	32.101	32.101	3.00	32,101	●
100	32	16.62	44	53	120	60	32.102	32.102	3.00	32,102	●
100	6	2.01	21	27	160	36	6.032	108.100	2.60	106,100	●
100	6	4.15	21	27	160	36	6.132	108.101	2.60	106,101	●
100	8	2.01	21	27	160	36	8.040	108.100	2.50	108,100	●
100	8	4.15	21	27	160	36	8.140	108.101	2.50	108,101	●
100	10	2.01	24	32	160	40	10.050	110.100	2.70	110,100	●
100	10	4.15	24	32	160	40	10.150	110.101	2.70	110,101	●
100	12	2.01	24	32	160	45	12.100	114.100	2.70	112,100	●
100	12	4.15	24	32	160	45	12.101	114.101	2.70	112,101	●
100	12	9.08	24	32	160	45	12.102	114.102	2.70	112,102	●
100	14	2.01	27	34	160	45	14.100	114.100	2.80	114,100	●
100	14	4.15	27	34	160	45	14.101	114.101	2.80	114,101	●
100	14	9.08	27	34	160	45	14.102	114.102	2.80	114,102	●
100	16	2.01	27	34	160	48	16.100	118.100	2.80	116,100	●
100	16	4.15	27	34	160	48	16.101	118.101	2.80	116,101	●
100	16	9.08	27	34	160	48	16.102	118.102	2.80	116,102	●
100	18	2.01	33	42	160	48	18.100	118.100	3.20	118,100	●
100	18	4.15	33	42	160	48	18.101	118.101	3.20	118,101	●
100	18	9.08	33	42	160	48	18.102	118.102	3.20	118,102	●
100	20	4.15	33	42	160	50	20.100	120.100	3.10	120,100	●

MQL 2-channel shrink fit chucks HSK-A for manual tool change

										Guhring no. 4613	
										Discount group 148	
HSK-A d ₃	for shank Ø d ₁ h ₆ mm	A mm ²	d ₂ mm	d ₄ mm	l ₁ mm	l ₂ mm	incl. setting screw no. 4621 ...	incl. filler no. 4622 ...	kg	Code no.	Availability
100	20	9.08	33	42	160	50	20.101	120.101	3.10	120,101	●
100	20	16.62	33	42	160	50	20.102	120.102	3.10	120,102	●
100	25	4.15	44	53	160	56	25.100	125.100	3.90	125,100	●
100	25	9.08	44	53	160	56	25.101	125.101	3.90	125,101	●
100	25	16.62	44	53	160	56	25.102	125.102	3.90	125,102	●
100	32	4.15	44	53	160	60	32.100	132.100	3.70	132,100	●
100	32	9.08	44	53	160	60	32.101	132.101	3.70	132,101	●
100	32	16.62	44	53	160	60	32.102	132.102	3.70	132,102	●

MQL 2-channel shrink fit chucks HSK-A for automatic tool change

Product information

- to Guhring MQL standard
- for 2-channel-systems
- balancing quality: G6.3 / 15,000 rev./min
- incl. balancing thread 4xM6/6xM6
- for tool shank tolerance h6
- also available in the lengths l₁ = 120 mm and 160 mm (concentricity 5 µm)

Scope of delivery

- incl. MQL adjustment screw Guhring no. 4621 and MQL coolant delivery set Guhring no. 4623
- special dimensions on request

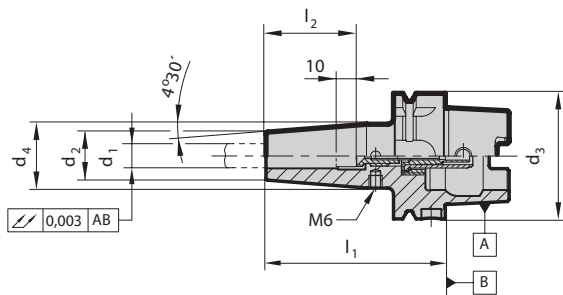

										Guhring no. 4614	
										Discount group 148	
HSK-A d ₃	for shank Ø d ₁ h ₆ mm	A mm ²	d ₂ mm	d ₄ mm	l ₁ mm	l ₂ mm	incl. setting screw no. 4621 ...	incl. cool. deliv. set 4623 ...	kg	Code no.	Availability
40	6	2.01	21	27	80	36	6.040	16.040	0.40	6,040	●
40	6	4.15	21	27	80	36	6.140	16.140	0.40	6,140	●
40	8	2.01	21	27	80	36	8.040	16.040	0.40	8,040	●
40	8	4.15	21	27	80	36	8.140	16.140	0.40	8,140	●
40	10	2.01	24	32	80	40	10.040	16.040	0.50	10,040	●
40	10	4.15	24	32	80	40	10.140	16.140	0.50	10,140	●
40	12	2.01	24	32	90	45	12.040	16.040	0.50	12,040	●
40	12	4.15	24	32	90	45	12.140	16.140	0.50	12,140	●
40	12	9.08	24	32	90	45	12.240	16.240	0.50	12,240	●
40	14	2.01	27	34	90	45	14.040	16.040	0.60	14,040	●
40	14	4.15	27	34	90	45	14.140	16.140	0.60	14,140	●
40	14	9.08	27	34	90	45	14.240	16.240	0.60	14,240	●
40	16	2.01	27	34	90	48	16.040	16.040	0.50	16,040	●
40	16	4.15	27	34	90	48	16.140	16.140	0.50	16,140	●
40	16	9.08	27	34	90	48	16.240	16.240	0.50	16,240	●
50	6	2.01	21	27	80	36	6.050	10.050	0.60	6,050	●
50	6	4.15	21	27	80	36	6.150	10.150	0.60	6,150	●
50	8	2.01	21	27	80	36	8.050	10.050	0.60	8,050	●
50	8	4.15	21	27	80	36	8.150	10.150	0.60	8,150	●
50	10	2.01	24	32	85	40	10.050	10.050	0.70	10,050	●
50	10	4.15	24	32	85	40	10.150	10.150	0.70	10,150	●
50	12	2.01	24	32	90	45	12.050	18.050	0.70	12,050	●
50	12	4.15	24	32	90	45	12.150	20.050	0.70	12,150	●
50	12	9.08	24	32	90	45	12.250	20.150	0.70	12,250	●
50	14	2.01	27	34	90	45	14.050	18.050	0.70	14,050	●
50	14	4.15	27	34	90	45	14.150	20.050	0.70	14,150	●
50	14	9.08	27	34	90	45	14.250	20.150	0.70	14,250	●
50	16	2.01	27	34	95	48	16.050	18.050	0.70	16,050	●

MQL 2-channel shrink fit chucks HSK-A for automatic tool change

HSK-A d ₃	for shank Ø d ₁ h ₆ mm	 A mm ²	d ₂ mm	d ₄ mm	l ₁ mm	l ₂ mm	incl. setting screw no. 4621 ...	incl. cool. deliv. set 4623 ...	kg	Guhring no.	4614		
										Discount group		148	
										Code no.	Availability		
50	16	4.15	27	34	95	48	16.150	20.050	0.70	16,150	●		
50	16	9.08	27	34	95	48	16.250	20.150	0.70	16,250	●		
50	18	2.01	33	42	95	48	18.050	18.050	0.90	18,050	●		
50	18	4.15	33	42	95	48	18.150	20.050	0.90	18,150	●		
50	18	9.08	33	42	95	48	18.250	20.150	0.90	18,250	●		
50	20	4.15	33	42	100	50	20.050	20.050	0.90	20,050	●		
50	20	9.08	33	42	100	50	20.150	20.150	0.90	20,150	●		
50	20	16.62	33	42	100	50	20.250	20.250	0.90	20,250	●		
63	6	2.01	21	27	80	36	6.100	10.063	0.70	6,063	●		
63	6	4.15	21	27	80	36	6.101	10.163	0.70	6,163	●		
63	8	2.01	21	27	80	36	8.100	10.063	0.70	8,063	●		
63	8	4.15	21	27	80	36	8.101	10.163	0.70	8,163	●		
63	10	2.01	24	32	85	40	10.100	10.063	0.70	10,063	●		
63	10	4.15	24	32	85	40	10.101	10.163	0.70	10,163	●		
63	12	2.01	24	32	90	45	12.100	18.063	0.80	12,063	●		
63	12	4.15	24	32	90	45	12.101	20.063	0.80	12,163	●		
63	12	9.08	24	32	90	45	12.102	20.163	0.80	12,263	●		
63	14	2.01	27	34	90	45	14.100	18.063	0.80	14,063	●		
63	14	4.15	27	34	90	45	14.101	20.063	0.80	14,163	●		
63	14	9.08	27	34	90	45	14.102	20.163	0.80	14,263	●		
63	16	2.01	27	34	95	48	16.100	18.063	0.90	16,063	●		
63	16	4.15	27	34	95	48	16.101	20.063	0.90	16,163	●		
63	16	9.08	27	34	95	48	16.102	20.163	0.90	16,263	●		
63	18	2.01	33	42	95	48	18.100	18.063	0.90	18,063	●		
63	18	4.15	33	42	95	48	18.101	20.063	0.90	18,163	●		
63	18	9.08	33	42	95	48	18.102	20.163	0.90	18,263	●		
63	20	4.15	33	42	100	50	20.100	20.063	1.00	20,063	●		
63	20	9.08	33	42	100	50	20.101	20.163	1.00	20,163	●		
63	20	16.62	33	42	100	50	20.102	20.263	1.00	20,263	●		
63	25	4.15	44	53	115	56	25.100	32.063	1.00	25,063	●		
63	25	9.08	44	53	115	56	25.101	32.163	1.00	25,163	●		
63	25	16.62	44	53	115	56	25.102	32.263	1.00	25,263	●		
63	32	4.15	44	53	120	60	32.100	32.063	1.10	32,063	●		
63	32	9.08	44	53	120	60	32.101	32.163	1.10	32,163	●		
63	32	16.62	44	53	120	60	32.102	32.263	1.10	32,263	●		
63	6	2.01	21	27	120	36	6.032	208.063	0.90	206,063	●		
63	6	4.15	21	27	120	36	6.132	208.163	0.90	206,163	●		
63	8	2.01	21	27	120	36	8.040	208.063	1.00	208,063	●		
63	8	4.15	21	27	120	36	8.140	208.163	1.00	208,163	●		
63	10	2.01	24	32	120	40	10.050	210.063	1.10	210,063	●		
63	10	4.15	24	32	120	40	10.150	210.063	1.10	210,163	●		
63	12	2.01	24	32	120	45	12.100	214.063	1.20	212,063	●		
63	12	4.15	24	32	120	45	12.101	214.163	1.20	212,163	●		
63	12	9.08	24	32	120	45	12.102	214.263	1.20	212,263	●		
63	14	2.01	27	34	120	45	14.100	214.063	1.20	214,063	●		
63	14	4.15	27	34	120	45	14.101	214.163	1.20	214,163	●		
63	14	9.08	27	34	120	45	14.102	214.263	1.20	214,263	●		
63	16	2.01	27	34	120	48	16.100	218.063	1.20	216,063	●		
63	16	4.15	27	34	120	48	16.101	218.163	1.20	216,163	●		
63	16	9.08	27	34	120	48	16.102	218.263	1.20	216,263	●		
63	18	2.01	33	42	120	48	18.100	218.063	1.40	218,063	●		
63	18	4.15	33	42	120	48	18.101	218.163	1.40	218,163	●		
63	18	9.08	33	42	120	48	18.102	218.263	1.40	218,263	●		
63	20	4.15	33	42	120	50	20.100	220.063	1.40	220,063	●		
63	20	9.08	33	42	120	50	20.101	220.163	1.40	220,163	●		
63	20	16.62	33	42	120	50	20.102	220.263	1.40	220,263	●		
63	6	2.01	21	27	160	36	6.032	108.063	0.80	106,063	●		
63	6	4.15	21	27	160	36	6.132	108.163	0.80	106,163	●		
63	8	2.01	21	27	160	36	8.040	108.063	0.80	108,063	●		
63	8	4.15	21	27	160	36	8.140	108.163	0.80	108,163	●		
63	10	2.01	24	32	160	40	10.050	110.063	0.90	110,063	●		
63	10	4.15	24	32	160	40	10.150	110.163	0.90	110,163	●		
63	12	2.01	24	32	160	45	12.100	114.063	0.90	112,063	●		
63	12	4.15	24	32	160	45	12.101	114.163	0.90	112,163	●		
63	12	9.08	24	32	160	45	12.102	114.263	0.90	112,263	●		
63	14	2.01	27	34	160	45	14.100	114.063	1.00	114,063	●		
63	14	4.15	27	34	160	45	14.101	114.163	1.00	114,163	●		
63	14	9.08	27	34	160	45	14.102	114.263	1.00	114,263	●		

MQL 2-channel shrink fit chucks HSK-A for automatic tool change

											Guhring no. 4614	
											Discount group 148	
HSK-A	for shank Ø	 A	d ₂	d ₄	l ₁	l ₂	incl. setting screw no. 4621 ...	incl. cool. deliv. set 4623 ...	kg	Code no.	Availability	
d ₃	d ₁ h ₆ mm	mm ²	mm	mm	mm	mm						
63	16	2.01	27	34	160	48	16.100	118.063	1.00	116,063	●	
63	16	4.15	27	34	160	48	16.101	118.163	1.00	116,163	●	
63	16	9.08	27	34	160	48	16.102	118.263	1.00	116,263	●	
63	18	2.01	33	42	160	48	18.100	118.063	1.20	118,063	●	
63	18	4.15	33	42	160	48	18.101	118.163	1.20	118,163	●	
63	18	9.08	33	42	160	48	18.102	118.263	1.20	118,263	●	
63	20	4.15	33	42	160	50	20.100	120.063	1.20	120,063	●	
63	20	9.08	33	42	160	50	20.101	120.163	1.20	120,163	●	
63	20	16.62	33	42	160	50	20.102	120.263	1.20	120,263	●	
63	25	4.15	44	53	160	56	25.100	125.063	1.80	125,063	●	
63	25	9.08	44	53	160	56	25.101	125.163	1.80	125,163	●	
63	25	16.62	44	53	160	56	25.102	125.263	1.80	125,263	●	
63	32	4.15	44	53	160	60	32.100	132.063	1.70	132,063	●	
63	32	9.08	44	53	160	60	32.101	132.163	1.70	132,163	●	
63	32	16.62	44	53	160	60	32.102	132.263	1.70	132,263	●	
80	6	2.01	21	27	85	36	6.100	10.080	1.30	6,080	●	
80	6	4.15	21	27	85	36	6.101	10.180	1.30	6,180	●	
80	8	2.01	21	27	85	36	8.100	10.080	1.30	8,080	●	
80	8	4.15	21	27	85	36	8.101	10.180	1.30	8,180	●	
80	10	2.01	24	32	90	40	10.100	10.080	1.40	10,080	●	
80	10	4.15	24	32	90	40	10.101	10.180	1.40	10,180	●	
80	12	2.01	24	32	95	45	12.100	18.080	1.40	12,080	●	
80	12	4.15	24	32	95	45	12.101	32.080	1.40	12,180	●	
80	12	9.08	24	32	95	45	12.102	32.180	1.40	12,280	●	
80	14	2.01	27	34	95	45	14.100	18.080	1.50	14,080	●	
80	14	4.15	27	34	95	45	14.101	32.080	1.50	14,180	●	
80	14	9.08	27	34	95	45	14.102	32.180	1.50	14,280	●	
80	16	2.01	27	34	100	48	16.100	18.080	1.50	16,080	●	
80	16	4.15	27	34	100	48	16.101	32.080	1.50	16,180	●	
80	16	9.08	27	34	100	48	16.102	32.180	1.50	16,280	●	
80	18	2.01	33	42	100	48	18.100	18.080	1.70	18,080	●	
80	18	4.15	33	42	100	48	18.101	32.080	1.70	18,180	●	
80	18	9.08	33	42	100	48	18.102	32.180	1.70	18,280	●	
80	20	4.15	33	42	105	50	20.100	32.080	1.70	20,080	●	
80	20	9.08	33	42	105	50	20.101	32.180	1.70	20,180	●	
80	20	16.62	33	42	105	50	20.102	32.280	1.70	20,280	●	
80	25	4.15	44	53	115	56	25.100	32.080	2.20	25,080	●	
80	25	9.08	44	53	115	56	25.101	32.180	2.20	25,180	●	
80	25	16.62	44	53	115	56	25.102	32.280	2.20	25,280	●	
80	32	4.15	44	53	120	60	32.100	32.080	2.10	32,080	●	
80	32	9.08	44	53	120	60	32.101	32.180	2.10	32,180	●	
80	32	16.62	44	53	120	60	32.102	32.280	2.10	32,280	●	
100	6	2.01	21	27	85	36	6.100	10.100	2.10	6,100	●	
100	6	4.15	21	27	85	36	6.101	10.101	2.10	6,101	●	
100	8	2.01	21	27	85	36	8.100	10.100	2.20	8,100	●	
100	8	4.15	21	27	85	36	8.101	10.101	2.20	8,101	●	
100	10	2.01	24	32	90	40	10.100	10.100	2.30	10,100	●	
100	10	4.15	24	32	90	40	10.101	10.101	2.30	10,101	●	
100	12	2.01	24	32	95	45	12.100	18.100	2.30	12,100	●	
100	12	4.15	24	32	95	45	12.101	32.100	2.30	12,101	●	
100	12	9.08	24	32	95	45	12.102	32.101	2.30	12,102	●	
100	14	2.01	27	34	95	45	14.100	18.100	2.30	14,100	●	
100	14	4.15	27	34	95	45	14.101	32.100	2.30	14,101	●	
100	14	9.08	27	34	95	45	14.102	32.101	2.30	14,102	●	
100	16	2.01	27	34	100	48	16.100	18.100	2.30	16,100	●	
100	16	4.15	27	34	100	48	16.101	32.100	2.30	16,101	●	
100	16	9.08	27	34	100	48	16.102	32.101	2.30	16,102	●	
100	18	2.01	33	42	100	48	18.100	18.100	2.50	18,100	●	
100	18	4.15	33	42	100	48	18.101	32.100	2.50	18,101	●	
100	18	9.08	33	42	100	48	18.102	32.101	2.50	18,102	●	
100	20	4.15	33	42	105	50	20.100	32.100	2.50	20,100	●	
100	20	9.08	33	42	105	50	20.101	32.101	2.50	20,101	●	
100	20	16.62	33	42	105	50	20.102	32.102	2.50	20,102	●	
100	25	4.15	44	53	115	56	25.100	32.100	3.00	25,100	●	
100	25	9.08	44	53	115	56	25.101	32.101	3.00	25,101	●	
100	25	16.62	44	53	115	56	25.102	32.102	3.00	25,102	●	
100	32	4.15	44	53	120	60	32.100	32.100	3.00	32,100	●	
100	32	9.08	44	53	120	60	32.101	32.101	3.00	32,101	●	
100	32	16.62	44	53	120	60	32.102	32.102	3.00	32,102	●	

MQL 2-channel shrink fit chucks HSK-A for automatic tool change

										Guhring no. 4614	
										Discount group 148	
HSK-A d ₃	for shank Ø d ₁ h ₆ mm	 A mm ²	d ₂ mm	d ₄ mm	l ₁ mm	l ₂ mm	incl. setting screw no. 4621 ...	incl. cool. deliv. set 4623 ...	kg	Code no.	Availability
100	6	2.01	21	27	160	36	6.032	108.100	2.60	106,100	●
100	6	4.15	21	27	160	36	6.132	108.101	2.60	106,101	●
100	8	2.01	21	27	160	36	8.040	108.100	2.50	108,100	●
100	8	4.15	21	27	160	36	8.140	108.101	2.50	108,101	●
100	10	2.01	24	32	160	40	10.050	110.100	2.70	110,100	●
100	10	4.15	24	32	160	40	10.150	110.101	2.70	110,101	●
100	12	2.01	24	32	160	45	12.100	114.100	2.70	112,100	●
100	12	4.15	24	32	160	45	12.101	114.101	2.70	112,101	●
100	12	9.08	24	32	160	45	12.102	114.102	2.70	112,102	●
100	14	2.01	27	34	160	45	14.100	114.100	2.80	114,100	●
100	14	4.15	27	34	160	45	14.101	114.101	2.80	114,101	●
100	14	9.08	27	34	160	45	14.102	114.102	2.80	114,102	●
100	16	2.01	27	34	160	48	16.100	118.100	2.80	116,100	●
100	16	4.15	27	34	160	48	16.101	118.101	2.80	116,101	●
100	16	9.08	27	34	160	48	16.102	118.102	2.80	116,102	●
100	18	2.01	33	42	160	48	18.100	118.100	3.20	118,100	●
100	18	4.15	33	42	160	48	18.101	118.101	3.20	118,101	●
100	18	9.08	33	42	160	48	18.102	118.102	3.20	118,102	●
100	20	4.15	33	42	160	50	20.100	120.100	3.10	120,100	●
100	20	9.08	33	42	160	50	20.101	120.101	3.10	120,101	●
100	20	16.62	33	42	160	50	20.102	120.102	3.10	120,102	●
100	25	4.15	44	53	160	56	25.100	125.100	3.90	125,100	●
100	25	9.08	44	53	160	56	25.101	125.101	3.90	125,101	●
100	25	16.62	44	53	160	56	25.102	125.102	3.90	125,102	●
100	32	4.15	44	53	160	60	32.100	132.100	3.70	132,100	●
100	32	9.08	44	53	160	60	32.101	132.101	3.70	132,101	●
100	32	16.62	44	53	160	60	32.102	132.102	3.70	132,102	●

MQL 2-channel length setting screws for HSK-A

Product information

- to Guhring MQL standard
- for 2-channel-systems
- for the use of tool shanks to Guhring MQL standard
- black colour, corrosion protective coating to visually identify the 2-channel system

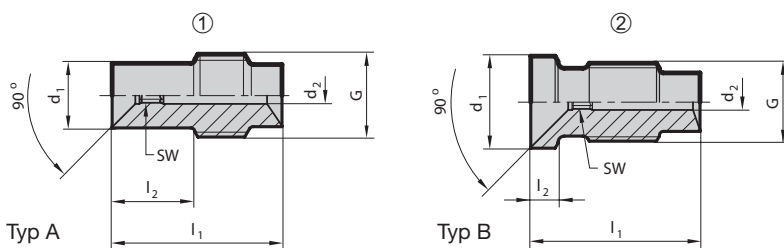

										Guhring no. 4621	
										Discount group 114	
HSK-A	holder Ø d ₁ mm	 für A mm ²	d ₂ mm	l ₁ mm	l ₂ mm	G	SW	Bild	Code no.	Availability	
32	6	2.01	2	25.8	2.5	M5x0.8	1.5	2	6,032	●	
32	6	4.15	2.9	25.8	2.5	M5x0.8	2	2	6,132	●	
32	8	2.01	2	21	3	M7x1	1.5	2	8,032	●	
32	8	4.15	2.9	21	3	M7x1	2	2	8,132	●	
32	10	2.01	2	22	3.5	M8x1	1.5	2	10,032	●	
32	10	4.15	2.9	22	3.5	M8x1	2	2	10,132	●	
32	12	2.01	2	22	3.5	M10x1	1.5	2	12,032	●	
32	12	4.15	2.9	22	3.5	M10x1	2	2	12,132	●	

MQL 2-channel length setting screws for HSK-A

HSK-A	holder Ø d ₁ mm	 für A mm ²	d ₂ mm	l ₁ mm	l ₂ mm	G	SW	Bild	Guhring no.	4621		
									Discount group		114	
									Code no.	Availability		
40	6	2.01	2	26.5	11	M7x1	1.5	1	6,040	●		
40	6	4.15	2.9	26.5	11	M7x1	2	1	6,140	●		
40	8	2.01	2	26.5	3	M7x1	1.5	2	8,040	●		
40	8	4.15	2.9	26.5	3	M7x1	2	2	8,140	●		
40	10	2.01	2	22.2	3.5	M8x1	1.5	2	10,040	●		
40	10	4.15	2.9	22.2	3.5	M8x1	2	2	10,140	●		
40	12	2.01	2	26.5	3.5	M10x1	1.5	2	12,040	●		
40	12	4.15	2.9	26.5	3.5	M10x1	2	2	12,140	●		
40	12	9.08	4.1	26.5	3.5	M10x1	3	2	12,240	●		
40	14	2.01	2	26.5	4.5	M10x1	1.5	2	14,040	●		
40	14	4.15	2.9	26.5	4.5	M10x1	2	2	14,140	●		
40	14	9.08	4.1	26.5	4.5	M10x1	3	2	14,240	●		
40	16	2.01	2	23.5	5.5	M12x1	1.5	2	16,040	●		
40	16	4.15	2.9	23.5	5.5	M12x1	2	2	16,140	●		
40	16	9.08	4.1	23.5	5.5	M12x1	3	2	16,240	●		
50	6	2.01	2	22	10	M8x1	1.5	1	6,050	●		
50	6	4.15	2.9	22	10	M8x1	2	1	6,150	●		
50	8	2.01	2	22	3	M8x1	1.5	2	8,050	●		
50	8	4.15	2.9	22	3	M8x1	2	2	8,150	●		
50	10	2.01	2	23	3.5	M8x1	1.5	2	10,050	●		
50	10	4.15	2.9	23	3.5	M8x1	2	2	10,150	●		
50	12	2.01	2	23.7	3.5	M10x1	1.5	2	12,050	●		
50	12	4.15	2.9	23.7	3.5	M10x1	2	2	12,150	●		
50	12	9.08	4.1	23.7	3.5	M10x1	3	2	12,250	●		
50	14	2.01	2	23.7	4.5	M10x1	1.5	2	14,050	●		
50	14	4.15	2.9	23.7	4.5	M10x1	2	2	14,150	●		
50	14	9.08	4.1	23.7	4.5	M10x1	3	2	14,250	●		
50	16	2.01	2	25.7	5.5	M12x1	1.5	2	16,050	●		
50	16	4.15	2.9	25.7	5.5	M12x1	2	2	16,150	●		
50	16	9.08	4.1	25.7	5.5	M12x1	3	2	16,250	●		
50	18	2.01	2	25.7	6.5	M12x1	1.5	2	18,050	●		
50	18	4.15	2.9	25.7	6.5	M12x1	2	2	18,150	●		
50	18	9.08	4.1	25.7	6.5	M12x1	3	2	18,250	●		
50	20	4.15	2.9	27.5	6.5	M16x1	2	2	20,050	●		
50	20	9.08	4.1	27.5	6.5	M16x1	3	2	20,150	●		
50	20	16.62	5.4	27.5	6.5	M16x1	4	2	20,250	●		
63/80/100	6	2.01	2	20.5	10	M10x1	1.5	1	6,100	●		
63/80/100	6	4.15	2.9	20.5	10	M10x1	2	1	6,101	●		
63/80/100	8	2.01	2	20.5	10	M10x1	1.5	1	8,100	●		
63/80/100	8	4.15	2.9	20.5	10	M10x1	2	1	8,101	●		
63/80/100	10	2.01	2	21.2	3.5	M10x1	1.5	2	10,100	●		
63/80/100	10	4.15	2.9	21.2	3.5	M10x1	2	2	10,101	●		
63/80/100	12	2.01	2	21.7	3.5	M10x1	1.5	2	12,100	●		
63/80/100	12	4.15	2.9	21.7	3.5	M10x1	2	2	12,101	●		
63/80/100	12	9.08	4.1	21.7	3.5	M10x1	3	2	12,102	●		
63/80/100	14	2.01	2	21.8	4.5	M10x1	1.5	2	14,100	●		
63/80/100	14	4.15	2.9	21.8	4.5	M10x1	2	2	14,101	●		
63/80/100	14	9.08	4.1	21.8	4.5	M10x1	3	2	14,102	●		
63/80/100	16	2.01	2	23.7	5.5	M12x1	1.5	2	16,100	●		
63/80/100	16	4.15	2.9	23.7	5.5	M12x1	2	2	16,101	●		
63/80/100	16	9.08	4.1	23.7	5.5	M12x1	3	2	16,102	●		
63/80/100	18	2.01	2	23.8	6.5	M12x1	1.5	2	18,100	●		
63/80/100	18	4.15	2.9	23.8	6.5	M12x1	2	2	18,101	●		
63/80/100	18	9.08	4.1	23.8	6.5	M12x1	3	2	18,102	●		
63/80/100	20	4.15	2.9	26.7	6.5	M16x1	2	2	20,100	●		
63/80/100	20	9.08	4.1	26.7	6.5	M16x1	3	2	20,101	●		
63/80/100	20	16.62	5.4	26.7	6.5	M16x1	4	2	20,102	●		
63/80/100	25	4.15	2.9	30.6	10	M16x1	2	2	25,100	●		
63/80/100	25	9.08	4.1	30.6	10	M16x1	3	2	25,101	●		
63/80/100	25	16.62	5.4	30.6	10	M16x1	4	2	25,102	●		
63/80/100	32	4.15	2.9	31.6	14	M16x1	2	2	32,100	●		
63/80/100	32	9.08	4.1	31.6	14	M16x1	3	2	32,101	●		
63/80/100	32	16.62	5.4	31.6	14	M16x1	4	2	32,102	●		

MQL 2-channel coolant delivery set HSK-A (filler)

Product information

- to Guhring MQL standard
- for 2-channel-systems
- for tool holders with manual tool change
- sealed thanks to bypass system

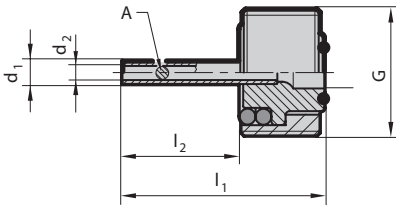

Guhring no. **4622**

Discount group **114**

for HSK-A	for clamp. Ø mm	 A mm ²	d ₁ mm	d ₂ mm	l ₁ mm	l ₂ mm	G	for chuck length	Code no.	Availability
40	6-16	2.01	1.9	1.6	22.8	14.5	M12x1	std.	16,040	●
40	6-16	4.15	2.8	2.3	22.8	14.5	M12x1	std.	16,140	●
40	12-16	9.08	4	3.4	22.6	14.3	M12x1	std.	16,240	●
50	6-10	2.01	1.9	1.6	26.3	16	M16x1.0	std.	10,050	●
50	6-10	4.15	2.8	2.3	26.3	16	M16x1.0	std.	10,150	●
50	12-18	2.01	1.9	1.6	24.2	13.9	M16x1.0	std.	18,050	●
50	12-20	4.15	2.8	2.3	24.2	13.9	M16x1.0	std.	20,050	●
50	12-20	9.08	4	3.4	24.2	13.9	M16x1.0	std.	20,150	●
50	20	16.62	5.3	4.6	24.2	13.9	M16x1.0	std.	20,250	●
63	6-10	2.01	1.9	1.6	26.4	14.1	M18x1.0	std.	10,063	●
63	6-10	4.15	2.8	2.3	26.4	14.1	M18x1.0	std.	10,163	●
63	12-18	2.01	1.9	1.6	25.3	13.0	M18x1.0	std.	18,063	●
63	12-20	4.15	2.8	2.3	25.3	13.0	M18x1.0	std.	20,063	●
63	12-20	9.08	4.0	3.4	25.3	13.0	M18x1.0	std.	20,163	●
63	20	16.62	5.3	4.6	26.5	14.2	M18x1.0	std.	20,263	●
63	25-32	4.15	2.8	2.3	30.6	18.3	M18x1.0	std.	32,063	●
63	25-32	9.08	4.0	3.4	30.6	18.3	M18x1.0	std.	32,163	●
63	25-32	16.62	5.3	4.6	30.6	18.3	M18x1.0	std.	32,263	●
63	6-8	2.01	1.9	1.6	66.4	54.1	M18x1.0	120	208,063	●
63	6-8	4.15	2.8	2.3	66.4	54.1	M18x1.0	120	208,163	●
63	10	2.01	1.9	1.6	61.4	49.1	M18x1.0	120	210,063	●
63	10	4.15	2.8	2.3	61.4	49.1	M18x1.0	120	210,163	●
63	12-14	2.01	1.9	1.6	55.3	43.0	M18x1.0	120	214,063	●
63	12-14	4.15	2.8	2.3	55.3	43.0	M18x1.0	120	214,163	●
63	12-14	9.08	4.0	3.4	55.3	43.0	M18x1.0	120	214,263	●
63	16-18	2.01	1.9	1.6	50.3	38.0	M18x1.0	120	218,063	●
63	16-18	4.15	2.8	2.3	50.3	38.0	M18x1.0	120	218,163	●
63	16-18	9.08	4.0	3.4	50.3	38.0	M18x1.0	120	218,263	●
63	20	4.15	2.8	2.3	46.5	34.2	M18x1.0	120	220,063	●
63	20	9.08	4.0	3.4	46.5	34.2	M18x1.0	120	220,163	●
63	20	16.62	5.3	4.6	46.5	34.2	M18x1.0	120	220,263	●
63	6-8	2.01	1.9	1.6	106.4	94.1	M18x1.0	160	108,063	●
63	6-8	4.15	2.8	2.3	106.4	94.1	M18x1.0	160	108,163	●
63	10	2.01	1.9	1.6	101.4	89.1	M18x1.0	160	110,063	●
63	10	4.15	2.8	2.3	101.4	89.1	M18x1.0	160	110,163	●
63	12-14	2.01	1.9	1.6	95.3	83.0	M18x1.0	160	114,063	●
63	12-14	4.15	2.8	2.3	95.3	83.0	M18x1.0	160	114,163	●
63	12-14	9.08	4.0	3.4	95.3	83.0	M18x1.0	160	114,263	●
63	16-18	2.01	1.9	1.6	90.3	78.0	M18x1.0	160	118,063	●
63	16-18	4.15	2.8	2.3	90.3	78.0	M18x1.0	160	118,163	●
63	16-18	9.08	4.0	3.4	90.3	78.0	M18x1.0	160	118,263	●
63	20	4.15	2.8	2.3	86.5	74.2	M18x1.0	160	120,063	●
63	20	9.08	4.0	3.4	86.5	74.2	M18x1.0	160	120,163	●
63	20	16.62	5.3	4.6	86.5	74.2	M18x1.0	160	120,263	●
63	25	4.15	2.8	2.3	75.6	63.3	M18x1.0	160	125,063	●
63	25	9.08	4.0	3.4	75.6	63.3	M18x1.0	160	125,163	●
63	25	16.62	5.3	4.6	75.6	63.3	M18x1.0	160	125,263	●
63	32	4.15	2.8	2.3	70.6	58.3	M18x1.0	160	132,063	●
63	32	9.08	4.0	3.4	70.6	58.3	M18x1.0	160	132,163	●
63	32	16.62	5.3	4.6	70.6	58.3	M18x1.0	160	132,263	●
80	6-10	2.01	1.9	1.6	29.0	14.6	M20x1.5	std.	10,080	●
80	6-10	4.15	2.8	2.3	29.0	14.6	M20x1.5	std.	10,180	●
80	12-18	2.01	1.9	1.6	27.9	13.5	M20x1.5	std.	18,080	●
80	12-32	4.15	2.8	2.3	27.9	13.5	M20x1.5	std.	32,080	●
80	12-32	9.08	4.0	3.4	27.9	13.5	M20x1.5	std.	32,180	●
80	20-32	16.62	5.3	4.6	28.4	14.0	M20x1.5	std.	32,280	●

MQL 2-channel coolant delivery set HSK-A (filler)

										Guhring no. 4622	
										Discount group 114	
for HSK-A	for clamp. Ø mm	 A mm ²	d ₁ mm	d ₂ mm	l ₁ mm	l ₂ mm	G	for chuck length	Code no.	Availability	
100	6-10	2.01	1.9	1.6	29.0	12.6	M24x1.5	std.	10,100	●	
100	6-10	4.15	2.8	2.3	29.0	12.6	M24x1.5	std.	10,101	●	
100	12-18	2.01	1.9	1.6	27.9	11.5	M24x1.5	std.	18,100	●	
100	12-32	4.15	2.8	2.3	27.9	11.5	M24x1.5	std.	32,100	●	
100	12-32	9.08	4.0	3.4	27.9	11.5	M24x1.5	std.	32,101	●	
100	20-32	16.62	5.3	4.6	28.4	12.0	M24x1.5	std.	32,102	●	
100	6-8	2.01	1.9	1.6	104.0	87.6	M24x1.5	160	108,100	●	
100	6-8	4.15	2.8	2.3	104.0	87.6	M24x1.5	160	108,101	●	
100	10	2.01	1.9	1.6	99.0	82.6	M24x1.5	160	110,100	●	
100	10	4.15	2.8	2.3	99.0	82.6	M24x1.5	160	110,101	●	
100	12-14	2.01	1.9	1.6	92.9	76.5	M24x1.5	160	114,100	●	
100	12-14	4.15	2.8	2.3	92.9	76.5	M24x1.5	160	114,101	●	
100	12-14	9.08	4.0	3.4	92.9	76.5	M24x1.5	160	114,102	●	
100	16-18	2.01	1.9	1.6	87.9	71.5	M24x1.5	160	118,100	●	
100	16-18	4.15	2.8	2.3	87.9	71.5	M24x1.5	160	118,101	●	
100	16-18	9.08	4.0	3.4	87.9	71.5	M24x1.5	160	118,102	●	
100	20	4.15	2.8	2.3	83.4	67.0	M24x1.5	160	120,100	●	
100	20	9.08	4.0	3.4	83.4	67.0	M24x1.5	160	120,101	●	
100	20	16.62	5.3	4.6	83.4	67.0	M24x1.5	160	120,102	●	
100	25	4.15	2.8	2.3	73.4	57.0	M24x1.5	160	125,100	●	
100	25	9.08	4.0	3.4	73.4	57.0	M24x1.5	160	125,101	●	
100	25	16.62	5.3	4.6	73.4	57.0	M24x1.5	160	125,102	●	
100	32	4.15	2.8	2.3	68.4	52.0	M24x1.5	160	132,100	●	
100	32	9.08	4.0	3.4	68.4	52.0	M24x1.5	160	132,101	●	
100	32	16.62	5.3	4.6	68.4	52.0	M24x1.5	160	132,102	●	

MQL 2-channel coolant delivery set HSK-A

Product information

- to Guhring MQL standard
- for 2-channel-systems
- for tool holders with automatic tool change
- sealed thanks to bypass system
- "Crashsafe" design similar to DIN 69090-2 delivery collar
- all dimensions to DIN 69895 unless stated

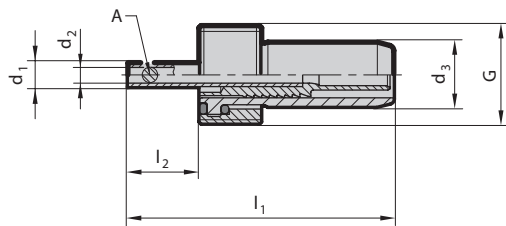

										Guhring no. 4623	
										Discount group 114	
for HSK-A	for clamp. Ø mm	 A mm ²	d ₁ mm	d ₂ mm	d ₃ mm	l ₁ mm	l ₂ mm	G	for chuck length	Code no.	Availability
40	6-16	2.01	1.9	1.6	8	43.3	14.5	M12x1	std.	16,040	●
40	6-16	4.15	2.8	2.3	8	43.3	14.5	M12x1	std.	16,140	●
40	12-16	9.08	4.0	3.4	8	43.1	14.3	M12x1	std.	16,240	●
50	6-10	2.01	1.9	1.6	10	48.6	16.0	M16x1.0	std.	10,050	●
50	6-10	4.15	2.8	2.3	10	48.6	16.0	M16x1.0	std.	10,150	●
50	12-18	2.01	1.9	1.6	10	46.5	13.9	M16x1.0	std.	18,050	●
50	12-20	4.15	2.8	2.3	10	46.5	13.9	M16x1.0	std.	20,050	●
50	12-20	9.08	4.0	3.4	10	46.5	13.9	M16x1.0	std.	20,150	●
50	20	16.62	5.3	4.6	10	46.5	13.9	M16x1.0	std.	20,250	●
63	6-10	2.01	1.9	1.6	12	50.0	14.1	M18x1.0	std.	10,063	●
63	6-10	4.15	2.8	2.3	12	50.0	14.1	M18x1.0	std.	10,163	●
63	12-18	2.01	1.9	1.6	12	48.8	13.0	M18x1.0	std.	18,063	●
63	12-20	4.15	2.8	2.3	12	48.8	13.0	M18x1.0	std.	20,063	●
63	12-20	9.08	4.0	3.4	12	48.8	13.0	M18x1.0	std.	20,163	●
63	20	16.62	5.3	4.6	12	50.0	14.2	M18x1.0	std.	20,263	●

										Guhring no. 4623	
										Discount group 114	
for HSK-A	for clamp. Ø mm	 A mm ²	d ₁ mm	d ₂ mm	d ₃ mm	l ₁ mm	l ₂ mm	G	for chuck length	Code no.	Availability
63	25-32	4.15	2.8	2.3	12	54.1	18.3	M18x1.0	std.	32,063	●
63	25-32	9.08	4.0	3.4	12	54.1	18.3	M18x1.0	std.	32,163	●
63	25-32	16.62	5.3	4.6	12	54.1	18.3	M18x1.0	std.	32,263	●
63	6-8	2.01	1.9	1.6	12	90.0	54.1	M18x1.0	120	208,063	●
63	6-8	4.15	2.8	2.3	12	90.0	54.1	M18x1.0	120	208,163	●
63	10	2.01	1.9	1.6	12	85.0	49.1	M18x1.0	120	210,063	●
63	10	4.15	2.8	2.3	12	85.0	49.1	M18x1.0	120	210,163	●
63	12-14	2.01	1.9	1.6	12	78.8	43.0	M18x1.0	120	214,063	●
63	12-14	4.15	2.8	2.3	12	78.8	43.0	M18x1.0	120	214,163	●
63	12-14	9.08	4.0	3.4	12	78.8	43.0	M18x1.0	120	214,263	●
63	16-18	2.01	1.9	1.6	12	73.8	38.0	M18x1.0	120	218,063	●
63	16-18	4.15	2.8	2.3	12	73.8	38.0	M18x1.0	120	218,163	●
63	16-18	9.08	4.0	3.4	12	73.8	38.0	M18x1.0	120	218,263	●
63	20	4.15	2.8	2.3	12	70.0	34.2	M18x1.0	120	220,063	●
63	20	9.08	4.0	3.4	12	70.0	34.2	M18x1.0	120	220,163	●
63	20	16.62	5.3	4.6	12	70.0	34.2	M18x1.0	120	220,263	●
63	6-8	2.01	1.9	1.6	12	130.0	94.1	M18x1.0	160	108,063	●
63	6-8	4.15	2.8	2.3	12	130.0	94.1	M18x1.0	160	108,163	●
63	10	2.01	1.9	1.6	12	125.0	89.1	M18x1.0	160	110,063	●
63	10	4.15	2.8	2.3	12	125.0	89.1	M18x1.0	160	110,163	●
63	12-14	2.01	1.9	1.6	12	118.8	83.0	M18x1.0	160	114,063	●
63	12-14	4.15	2.8	2.3	12	118.8	83.0	M18x1.0	160	114,163	●
63	12-14	9.08	4.0	3.4	12	118.8	83.0	M18x1.0	160	114,263	●
63	16-18	2.01	1.9	1.6	12	113.8	78.0	M18x1.0	160	118,063	●
63	16-18	4.15	2.8	2.3	12	113.8	78.0	M18x1.0	160	118,163	●
63	16-18	9.08	4.0	3.4	12	113.8	78.0	M18x1.0	160	118,263	●
63	20	4.15	2.8	2.3	12	110.0	74.2	M18x1.0	160	120,063	●
63	20	9.08	4.0	3.4	12	110.0	74.2	M18x1.0	160	120,163	●
63	20	16.62	5.3	4.6	12	110.0	74.2	M18x1.0	160	120,263	●
63	25	4.15	2.8	2.3	12	99.1	63.3	M18x1.0	160	125,063	●
63	25	9.08	4	3.4	12	99.1	63.3	M18x1.0	160	125,163	●
63	25	16.62	5.3	4.6	12	99.1	63.3	M18x1.0	160	125,263	●
63	32	4.15	2.8	2.3	12	94.1	58.3	M18x1.0	160	132,063	●
63	32	9.08	4.0	3.4	12	94.1	58.3	M18x1.0	160	132,163	●
63	32	16.62	5.3	4.6	12	94.1	58.3	M18x1.0	160	132,263	●
80	6-10	2.01	1.9	1.6	14	54.2	14.6	M20x1.5	std.	10,080	●
80	6-10	4.15	2.8	2.3	14	54.2	14.6	M20x1.5	std.	10,180	●
80	12-18	2.01	1.9	1.6	14	53.1	13.5	M20x1.5	std.	18,080	●
80	12-32	4.15	2.8	2.3	14	53.1	13.5	M20x1.5	std.	32,080	●
80	12-32	9.08	4.0	3.4	14	53.1	13.5	M20x1.5	std.	32,180	●
80	20-32	16.62	5.3	4.6	14	53.6	14.0	M20x1.5	std.	32,280	●
100	6-10	2.01	1.9	1.6	14	56.2	12.6	M24x1.5	std.	10,100	●
100	6-10	4.15	2.8	2.3	14	56.2	12.6	M24x1.5	std.	10,101	●
100	12-18	2.01	1.9	1.6	14	55.1	11.5	M24x1.5	std.	18,100	●
100	12-32	4.15	2.8	2.3	14	55.1	11.5	M24x1.5	std.	32,100	●
100	12-32	9.08	4.0	3.4	14	55.1	11.5	M24x1.5	std.	32,101	●
100	20-32	16.62	5.3	4.6	14	55.6	12.0	M24x1.5	std.	32,102	●
100	6-8	2.01	1.9	1.6	12	131.2	87.6	M24x1.5	160	108,100	●
100	6-8	4.15	2.8	2.3	12	131.2	87.6	M24x1.5	160	108,101	●
100	10	2.01	1.9	1.6	12	126.2	82.6	M24x1.5	160	110,100	●
100	10	4.15	2.8	2.3	12	126.2	82.6	M24x1.5	160	110,101	●
100	12-14	2.01	1.9	1.6	12	120.1	76.5	M24x1.5	160	114,100	●
100	12-14	4.15	2.8	2.3	12	120.1	76.5	M24x1.5	160	114,101	●
100	12-14	9.08	4.0	3.4	12	120.1	76.5	M24x1.5	160	114,102	●
100	16-18	2.01	1.9	1.6	12	115.1	71.5	M24x1.5	160	118,100	●
100	16-18	4.15	2.8	2.3	12	115.1	71.5	M24x1.5	160	118,101	●
100	16-18	9.08	4.0	3.4	12	115.1	71.5	M24x1.5	160	118,102	●
100	20	4.15	2.8	2.3	12	110.6	67.0	M24x1.5	160	120,100	●
100	20	9.08	4.0	3.4	12	110.6	67.0	M24x1.5	160	120,101	●
100	20	16.62	5.3	4.6	12	110.6	67.0	M24x1.5	160	120,102	●
100	25	4.15	2.8	2.3	12	100.6	57.0	M24x1.5	160	125,100	●
100	25	9.08	4.0	3.4	12	100.6	57.0	M24x1.5	160	125,101	●
100	25	16.62	5.3	4.6	12	100.6	57.0	M24x1.5	160	125,102	●
100	32	4.15	2.8	2.3	12	95.6	52.0	M24x1.5	160	132,100	●
100	32	9.08	4.0	3.4	12	95.6	52.0	M24x1.5	160	132,101	●
100	32	16.62	5.3	4.6	12	95.6	52.0	M24x1.5	160	132,102	●

MQL HSK-A synchro tapping chucks for manual tool change

Product information

- for MQL single and double channel systems
- compensate synchronisation errors
- minimal length compensation in tension and compression direction balances very small pitch differences between synchro spindle and tap, which can cause high frictional forces on the thread flanks and increase thread quality and tool life
- length-setting screw allows 2 to 3 mm readjustment
- MQL pressure up to max. 10 bar
- mounted MQL coolant supply pipe
- Guhring MQL identifiable by green coloured ring

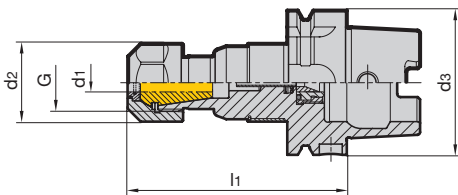

Scope of delivery

- incl. MQL coolant delivery set for manual tool change (filler)
- Incl. sealed IC/ER clamping nut Guhring no. 4306 (*see torque)
- incl. adjustment key for MQL adjustment screw
- order MQL adjustment screw Guhring no. 4305 separately
- order sealing washer Guhring no. 4335 separately
- order collet Guhring no. 4308 separately
- order chuck spanner Guhring no. 4913 for ER retaining nut separately



HSK-A d ₃	nom. size	for thread	G	d ₁ mm	d ₂ mm	l ₁ mm	tension/compr. ± mm	torque* Nm	kg	Code no.	Availability
63	ER20	M3.5-M14	M25x1.5	4.5-11	34	95.5	0.15	40	1.00	20,063	●
63	ER32	M3.5-M28	M40x1.5	4.5-20	50	109.0	0.15	170	1.50	32,063	●

Guhring no. 4298

Discount group 114

MQL HSK-A synchro tapping chucks for 2-channel systems for automatic tool change

Product information

- for 2-channel-systems
- compensate synchronisation errors
- minimal length compensation in tension and compression direction balances very small pitch differences between synchro spindle and tap, which can cause high frictional forces on the thread flanks and increase thread quality and tool life
- length-setting screw allows 2 to 3 mm readjustment
- MQL pressure up to max. 10 bar
- mounted MQL coolant supply pipe
- Guhring MQL identifiable by green coloured ring

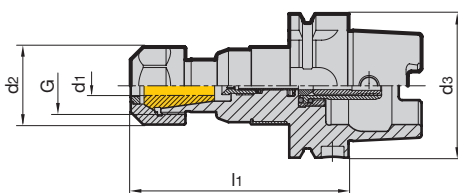

Scope of delivery

- incl. MQL coolant delivery set for automatic tool change
- Incl. sealed IC/ER clamping nut Guhring no. 4306 (*see torque)
- incl. adjustment key for MQL adjustment screw
- order MQL adjustment screw Guhring no. 4305 separately
- order sealing washer Guhring no. 4335 separately
- order collet Guhring no. 4308 separately
- order chuck spanner Guhring no. 4913 for ER retaining nut separately



HSK-A d ₃	nom. size	for thread	G	d ₁ mm	d ₂ mm	l ₁ mm	tension/compr. ± mm	torque* Nm	kg	Code no.	Availability
63	ER20	M3.5-M14	M25x1.5	4.5-11	34	95.5	0.15	40	1.00	20,063	●
63	ER32	M3.5-M28	M40x1.5	4.5-20	50	109.0	0.15	170	1.50	32,063	●
100	ER20	M3.5-M14	M25x1.5	4.5-11	34	102.0	0.15	40	2.40	20,100	●
100	ER32	M3.5-M28	M40x1.5	4.5-20	50	115.5	0.15	170	3.00	32,100	●

Guhring no. 4341

Discount group 114

HSK



HSK CLAMPING TECHNOLOGY



MOQ
BY GÜHRING

ONE CLAMPING SET
MANY NEW
POSSIBILITIES!





*SUITABLE FOR DIFFERENT
SPINDLE CONTOURS*



*MAXIMUM
CLAMPING FORCE*



*OPTIMAL COOLANT
SUPPLY – MQL &
CONVENTIONAL*



*STRAIGHT-
LINE COOLANT
THROUGHFLOW*

MQL
BY GÜHRING



4-POINT CLAMPING TECHNOLOGY FOR MQL TECHNICAL INFORMATION AND ADVANTAGES

GÜHROCLAMP



Our 4-point clamping system is suitable for radial manual clamping. Primarily designed for installation in spindles (short drilling spindles, multiple-spindle drilling heads).



Advantages:

- simple and hence more economic spindle manufacture
- short, small diameter spindles with constricted spindle bearing spacing
- suitable for a pressure up to 160 bar (for conventional internal cooling)
- fast response time thanks to uninterrupted MQL delivery
- compatible installation contour and application of our 4-point clamping set for conventional cooling

Internal contour of spindle

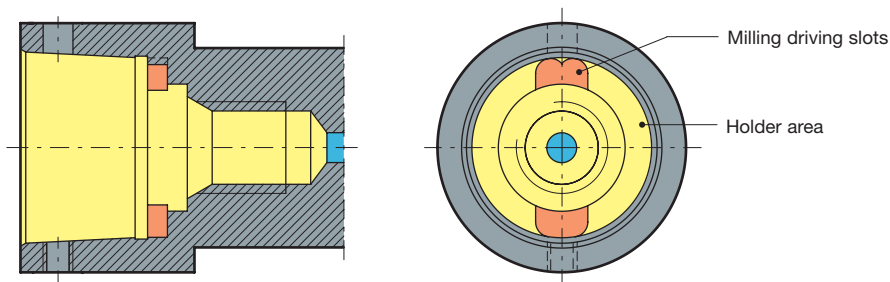

Installation and principle of operation

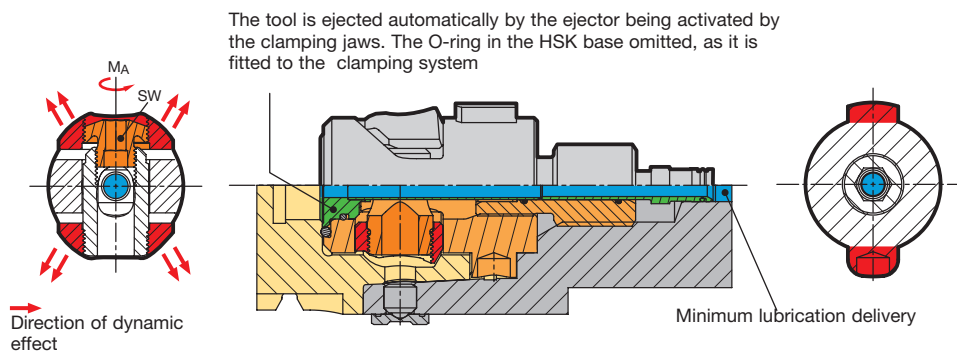

Bending, torsional and tightening moment for 4-point clamping sets for MQL

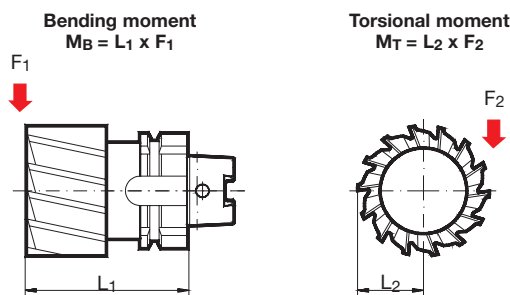

① We recommend M_A max. for rough machining and milling operations. For drilling and reaming operations a lower deviation of M_A max. up to 30% is permissible. Please check the torque with a torque wrench.

② Depending on temperature and lubricating conditions these values can be up to 15% lower.

③ Due to the screwed connection, M_T max. can be lower with adaptors.

HSK-C	max. torque M_A [Nm] ①	Key size	max. drawing force [kN] ②	max. linear bending moment M_B [Nm] ②	max. transferrable torsional moment M_T [Nm] ② ③
32	3.0	2.5	8.5	72	105
40	6.0	3.0	12.5	135	180
50	12.0	4.0	24.0	330	390
63	24.0	5.0	32.0	570	680
80	40.0	6.0	45.0	1000	1570
100	60.0	8.0	53.0	1620	4200

General notes: Our manual clamping sets must not be operated with motor-driven tools (impulse screwdriver or similar). The hexagonal key should not exceed the key size over its entire length, this largely prevents excessive torque being transferred. We recommend the T-handle hexagonal key, Guhring no. 4912. For accurate setting of the maximum torque and achieving the maximum interface rigidity, we recommend the application of a torque wrench, Guhring no. 4915 with hexagonal sockets, Guhring no. 4916. Production drawings of the spindle contour to suit direct installation are available on request, including .dxf.



MQL 4-point clamping set connection dimensions for new designs

Direct installation in spindle with MQL adaptor

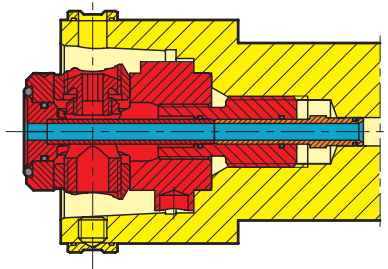

Short spindle adaptor with MQL delivery pipe

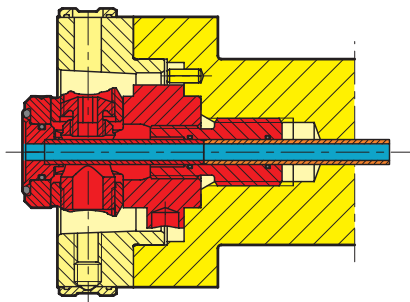

Adaptor (in front) with MQL delivery pipe

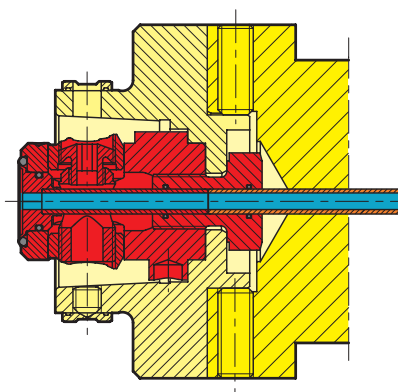

GÜHROCLAMP MQL 4-point clamping sets for MQL and IC

Product information

- for radial manual HSK tool clamping
- universal application for MQL and high-pressure IC
- the central and coaxial MQL supply with constant internal diameter prevents coolant from consolidating to DIN 69090-2
- For a coolant pressure up to 160 bar
- for clamping HSK-A/C shanks to ISO 12164-1/DIN 69893

Scope of delivery

- complete as shown in illustration
- Installation and operating instructions



GÜHROCLAMP

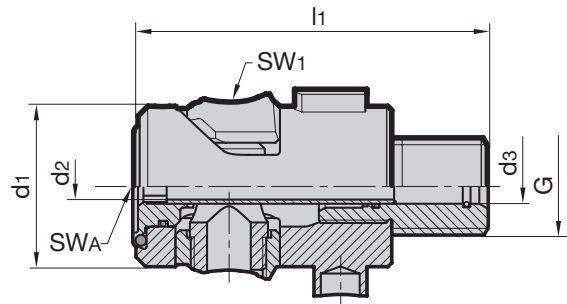

Guhring no.	4930
Discount group	114

HSK-C	d1 mm	d2 mm	d3 mm	l1 mm	G	SW1	SWA	kg	Code no.	Availability
32	16.7	3	4.1	41.75	M10	2.5	3	0.05	24,100	●
40	20.6	4	5.1	43.90	M12	3	4	0.09	30,100	●
50	25.5	5	7.1	54.20	M16	4	5	0.18	38,100	●
50	25.5	5	6.1	54.20	M16	4	5	0.18	38,200	●
63	33.0	6	7.1	72.20	M20	5	6	0.37	48,100	●
80	41.0	8	10.1	90.20	M24	6	8	0.70	60,100	●
100	52.0	10	12.1	107.10	M24	8	10	1.30	75,100	●

GÜHROCLAMP component parts for MQL 4-point clamping sets Guhring no. 4930

- retention screw only for adaptor
- If spindle cannot be locked, please use torque socket Guhring no. 4963

GÜHROCLAMP

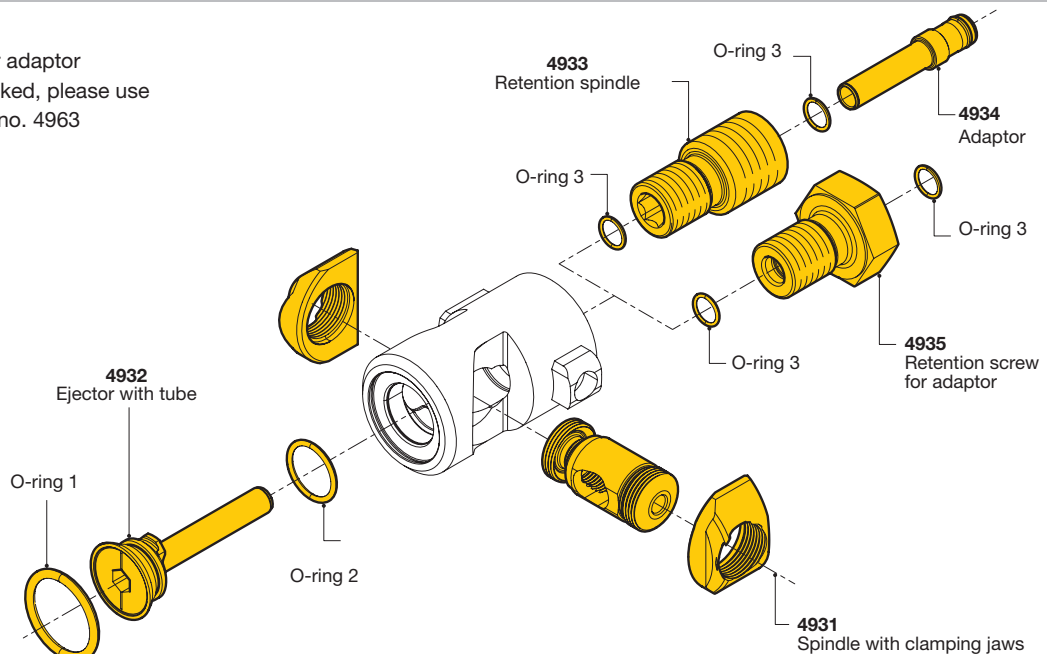

				4931		4932	
--	--	--	--	------	--	------	--

HSK-C	O-ring 1 mm	O-ring 2 mm	O-ring 3 mm	Spindle with clamping jaws	Unit price in € Discount group 114	Ejector with tube	Unit price in € Discount group 114
32	10,5x2,0	6,0x1,5	3,5x1/4x1	24,000		24,100	●
40	13,0x2,0	7,0x1,5	4,5x1,0/5,0x1,0	30,000		30,100	●
50	16,0x2,0	10,0x1,5	5,5x1,0/7x1,0	38,000		38,100	●
63	20,3x2,4	14,0x1,5	7,0x1,0	48,000		48,100	●
80	23,4x3,53	16,0x2,0	10,0x1,5	60,000		60,100	●
100	28,17x3,53	22,0x2,0	12,0x1,70	75,000		75,100	●

Retention spindles for GÜHROCLAMP MQL 4-point clamping sets

Product information

- retention spindle for direct installation in spindle

Scope of delivery

- complete as shown in illustration

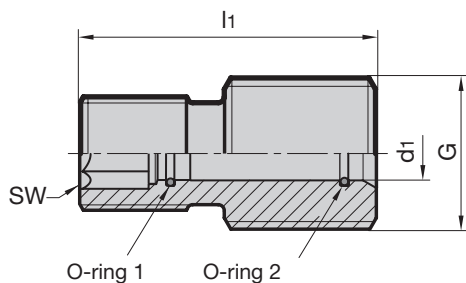

Guhring no. **4933**

Discount group **114**

for HSK-C	d ₁ mm	l ₁ mm	G	SW	O-ring 1	O-ring 2	Code no.	Availability
32	4.1	22.5	M10	4	3.5x1.0	4.0x1.0	24,100	●
40	5.1	23.2	M 12	5	4.5x1.0	5.0x1.0	30,100	●
50	7.1	27.0	M 16	6	5.5x1.0	7.0x1.0	38,100	●
50	6.1	27.0	M 16	6	5.5x1.0	5.5x1.0	38,200	●
63	7.1	39.0	M 20	8	7.0x1.0	7.0x1.0	48,100	●
80	10.1	50.0	M 24	10	10.0x1.5	10.0x1.5	60,100	●
100	12.1	60.0	M 24	12	12.0x1.70	12.0x1.70	75,100	●

Adaptor for GÜHROCLAMP MQL 4-point clamping sets

Product information

- Adaptor for direct installation in spindle and spindle adaptor (integrated) for coolant delivery and sealing

Scope of delivery

- complete as shown in illustration

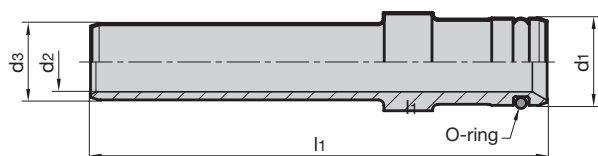

Guhring no. **4934**

Discount group **114**

for HSK-C	d ₁ mm	d ₂ mm	d ₃ mm	l ₁ mm	O-ring	Code no.	Availability
32	4.0	2.0	4.0	14	2.0 x 1.0	24,100	●
40	5.0	3.0	5.0	28	3.0 x 1.0	30,100	●
50	6.0	5.0	6.0	28	4.0 x 1.0	38,200	●
50	6.0	4.0	7.0	28	4.0 x 1.0	38,100	●
63	8.0	5.5	7.0	42	6.0 x 1.0	48,100	●
80	10.2	7.5	10.0	56	8.0 x 1.0	60,100	●
100	12.0	9.5	12.0	60	10.0 x 1.0	75,100	●

Retention screw for GÜHROCLAMP MQL 4-point clamping sets

Product information

- necessary for installation of MQL 4-point clamping set in spindle adaptors and module adaptor flange Guhring no. 4363, 4386, 4387 and 4713
- change against standard retention bolt

Scope of delivery

- complete as shown in illustration

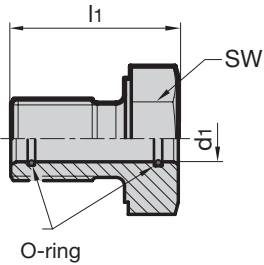

Guhring no. **4935**

Discount group **114**

for HSK-C	d ₁ mm	l ₁ mm	SW	O-ring 1	O-ring 2	torque Nm	Code no.	Availability
32	4.1	23.5	13	4x1.0	4x1.0	14	24,100	●
40	5.1	21	16	4.5x1.0	5x1.0	30	30,100	●
50	6.1	25	18	5.5x1.0	6x1.0	60	38,200	●
50	7.1	25	18	5.5x1.0	7x1.0	60	38,100	●
63	7.1	29	24	7x1.0	7x1.0	110	48,100	●
80	10.1	36	24	10x1.5	10x1.5	180	60,100	●
100	12.1	40	32	12x1.7	12x1.7	200	75,100	●

M contour clamping sets for MQL and IC

Product information

- HSK clamping sets compatible with M contour spindles and adaptors
- universal application for MQL and high-pressure IC
- the central, coaxial MQL supply with constant internal diameter ensures a uninterrupted coolant delivery to DIN 69090-2
- for a coolant pressure up to 160 bar
- for radial manual HSK tool clamping
- for clamping HSK-A/C shanks to ISO 12164-1/DIN 69893

Scope of delivery

- incl. adaptor with through hole for uninterrupted coolant delivery
- including installation and operating instructions
- order adaptor with spigot connection Guhring no. 4616 separately
- spindle connection dimensions on request

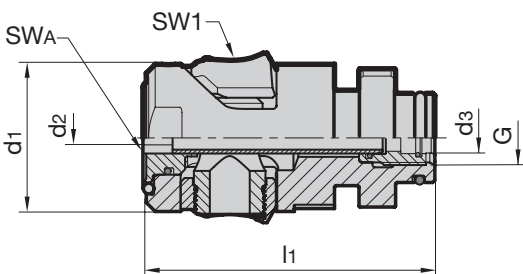

Guhring no. **4615**

Discount group **114**

HSK-C	d ₁ mm	d ₂ mm	d ₃ mm	l ₁ mm	G	SW1	SWA	Code no.	Availability
32	16.7	3.0	4.1	43.4	M8x1	2.5	3	24,000	●
40	20.6	4.0	5.1	48.3	M10x1	3	4	30,000	●
50	22.5	5.0	6.1	55.3	M12x1	4	5	38,100	●
50	22.5	5.0	7.1	55.3	M12x1	4	5	38,000	●
63	33.0	6.0	7.1	64.7	M12x1	5	6	48,000	●
80	41.0	8.0	10.1	75.3	M16x1	6	8	60,000	●
100	52.0	10.0	12.1	94.5	M18x1	8	10	75,000	●

Adaptor with spigot transition for M contour clamping set

Product information

- application on M contour clamping sets Guhring no. 4615 instead of adaptor with coolant transfer hole
- universal application for MQL and high-pressure IC
- for a coolant pressure up to 160 bar
- adaptor for spindles without coolant tube for uninterrupted coolant delivery
- spindle connection dimensions on request

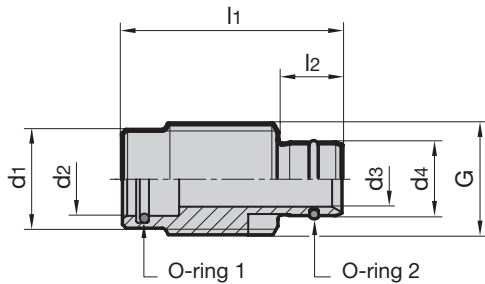

Guhring no. 4616
Discount group 114

for HSK-C	d ₁ mm	d ₂ mm	d ₃ mm	d ₄ mm	l ₁ mm	l ₂ mm	O-ring 1	O-ring 2	G	Code no.	Availability
32	-	3.5	3	5.00	14.4	5.4	3.5x1	3x1	M8x1	24,000	●
40	7.7	4.5	4	6.00	22.0	6.5	4.0x1	4x1	M10x1	30,000	●
50	8.5	5.5	5	8.00	23.0	7.5	5.5x1	6x1	M12x1	38,000	●
63	10.6	7.0	6	8.00	24.0	7.0	7.0x1	6x1	M12x1	48,000	●
80	-	10.0	8	11.30	23.3	8.3	10x1.5	8x1.5	M12x1	60,000	●
100	-	12.0	10	13.80	30.6	9.6	12x1.5	12x1.5	M18x1	75,000	●

Tool for the assembly / disassembly of M contour clamping sets

Product information

- for the assembly and disassembly of M contour clamping sets
- Guhring no. 4615

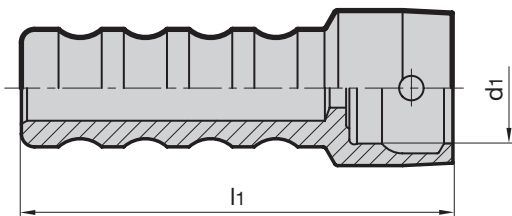

Guhring no. 4624
Discount group 114

for HSK	d ₁ mm	l ₁ mm	Code no.	Availability
32	17	119	32,000	●
40	21	121.5	40,000	●
50	26	127.5	50,000	●
63	34	132	63,000	●
80	42	143	80,000	●
100	53	152	100,000	●

MQL-CHECK 3000

PROVIDES AN OVERVIEW

Especially with minimal quantity lubrication, optimal delivery of the minimal coolant volume to the cutting edge is paramount. An insufficient delivery or a delayed response time respectively can lead to disastrous results such as premature wear, a deterioration in machining quality or even tool breakage. In contrast, excessive coolant volume results in increased costs through unnecessary coolant consumption and additional cleaning expense for components or machines as well as an unnecessary impact on the environment and personnel.

- ⇒ simple, quick measurements of the coolant volume directly at the tool point
- ⇒ ascertaining the actual response time, i.e. the time from starting the system to the coolant exiting at the tool point
- ⇒ reproduceable and at any time comparable measuring data
- ⇒ a workshop suitable system, wireless operation - in terms of power supply as well as data transfer
- ⇒ comparative measuring regarding function of MQL equipment, machine, spindle, tool holder and tool



Technical Data

Measuring range	5 to 60 ml/h
Tool diameter range	3 to 20 mm
Measuring position	0 to 90° (vertical and horizontal machining)
Power supply	battery

MQL-Check 3000 consists of:

- measuring unit incl. sender and magnetic base for installation with horizontal machining
- display facility with receiver
- measuring filter for measuring range up to 30 ml/h

Data interface and PC software are available as an option.

Introduction

Alongside the machine and tooling the costs for coolant are a considerable portion of the overall cost of the machining process. Therefore, a reduction in the cooling lubrication requirements offers a potential for cost savings.

The reduction of cooling lubricants is not only cost saving but is also of benefit to the environment and health protection. Guhring is one of the pioneers in the research and development of MQL that began in the mid 1990's.

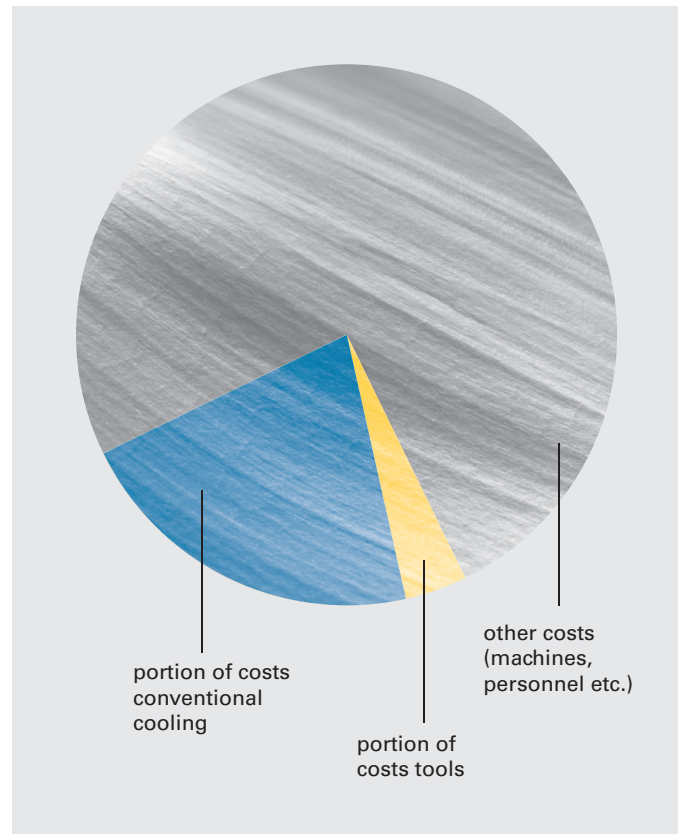

The aim of MQL machining

The acquisition of a new MQL cooling lubricant system is significantly less expensive than conventional cooling!

- reduction of thermal stresses at the tool point
- less tool wear
- effective chip evacuation from deep holes
- reduction of cooling lubricant requirement
- high cooling and lubrication effect especially in deep holes
- lowering the resulting costs such as:
 - component cleaning costs
 - cooling lubricant disposal costs
 - swarf disposal costs
- environment and health protection

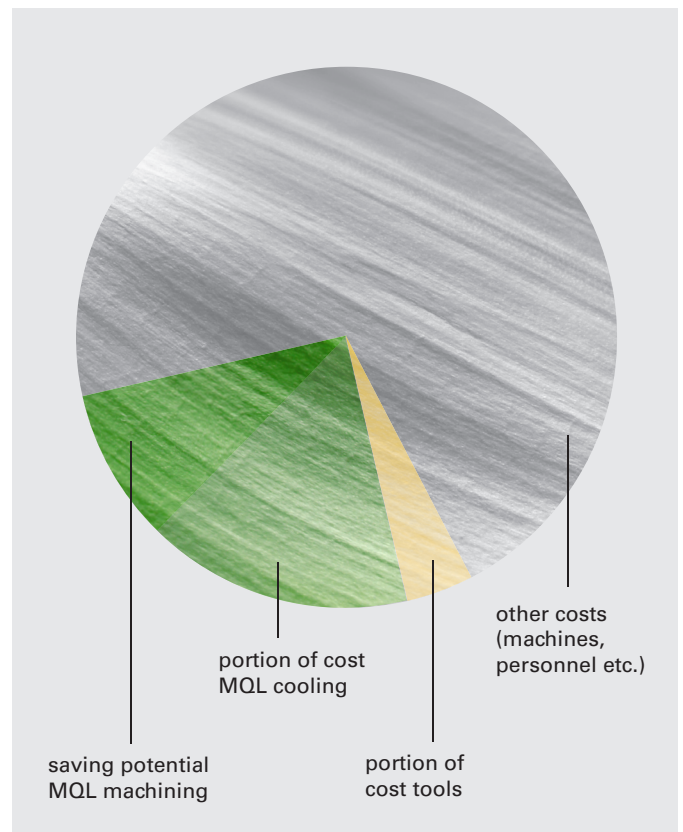

The development of present-day MQL systems

Thanks to the research in MQL machining Guhring created the pre-condition for a practical MQL technology. From the clamping set to the tool's cutting edge all the components were integrated in the development – the result was the first MQL delivery system.

Features:

- modular constructed and standardised system
- MQL and conventional clamping set are freely interchangeable thanks to an identical spindle contour
- hydraulic, shrink fit and synchro chucks are all designed for the MQL clamping set



Guhring's current MQL system

By incorporating the MQL length adjustment screw to Guhring's first MQL delivery system in 2007, the original drawback was eliminated. There is, therefore, currently a MQL delivery system available to the customer that optimally meets the requirements of the present-day production process.

Features of the first Guhring MQL delivery system:

- no lubricant delays
- special MQL coolant delivery unit
- MQL suitable tool shank end
- tapered length setting screw

The user, therefore, benefits from a standardised system and a clearly reduced stock keeping thanks to compatible components.



Optimally formed shank end! For a secure MQL delivery

The delivery of these extremely low coolant quantities directly to the effective area is of utmost importance. Hereby, the geometric design of the shank end plays a significant role! The Guhring developed conical shank end optimally satisfies the relevant MQL conditions.

Advantages of the tapered shank end:

- no lubricant delays
- minimal dead area
- simple operation
- cost-efficient production

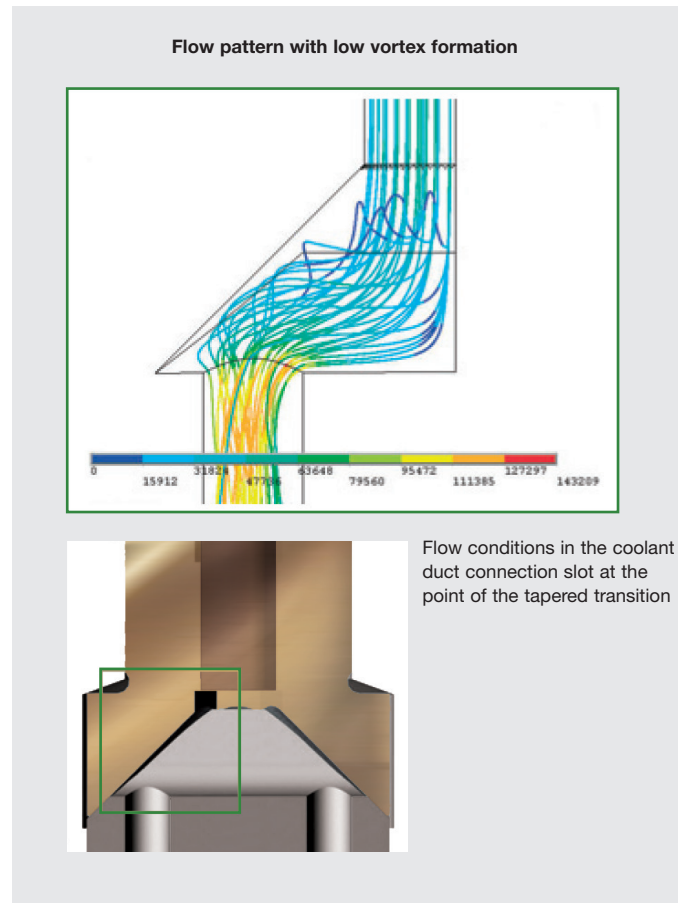

Keeping a cool point

With MQL the process temperature can be considerably reduced in comparison to dry machining resulting in longer tool life and an increased process reliability.

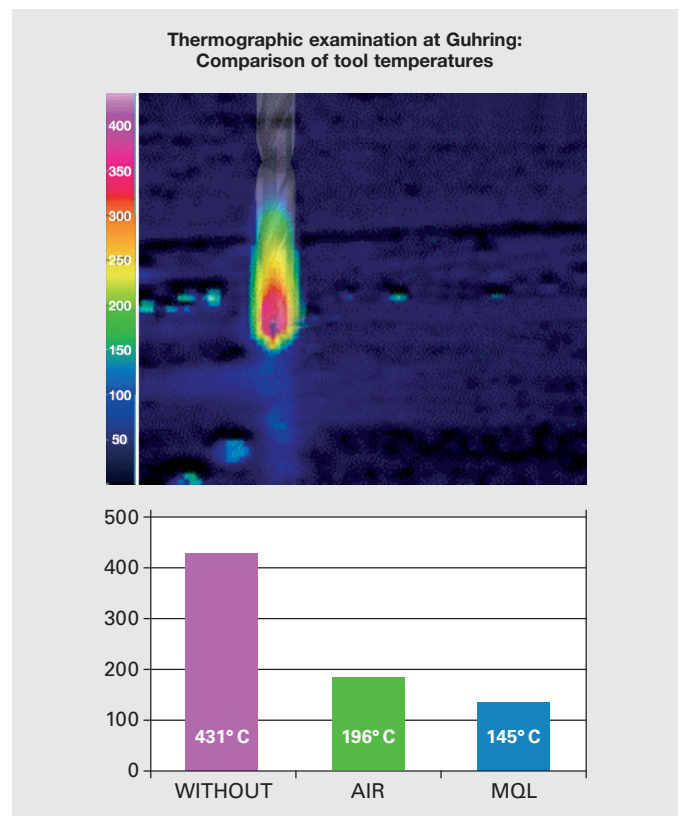

The best form for MQL!

Optimal MQL machining results thanks to the optimised tool geometry of RT 100 T!



1. Flute cross section:

The flute geometry of Guhring MQL tools ensures short chips that are optimally evacuated from deep holes.

2. Maximum coolant duct cross-section:

The cooling lubricant supply as well as the chip evacuation have been optimised through the tool's maximum coolant duct cross-section.

Flow speed comparison

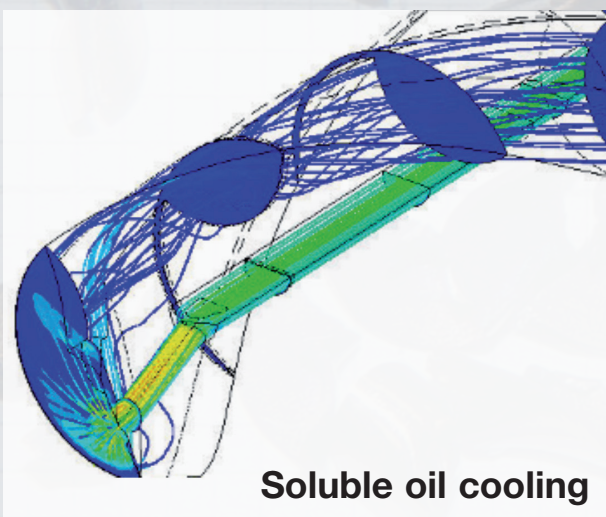
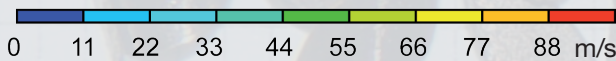
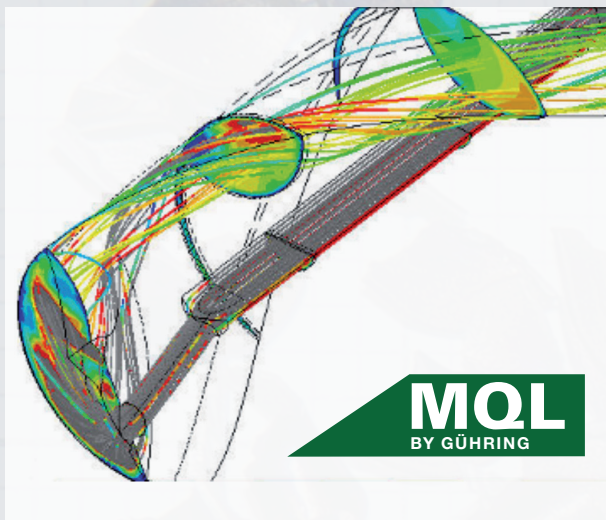

The flow speed

in the flute with MQL is 30.4 m/s.

The volume with MQL

is 6.960 l/h (std.litres air/h).

Tool \varnothing = 11.7 mm

Pressure at pump = 6 bar

Pressure at tool = 4 bar

The flow speed

In the flute with soluble oil is 3.5 m/s.

The volume with soluble oil

is 600 l/h (std.litres air/h).

Tool \varnothing = 11.7 mm

Pressure at pump = 60 bar

Pressure at tool = 31 bar

MQL system types

The provision of the MQL medium to the tool can be achieved in two ways: the aerosol mixture can be prepared outside the machine and conveyed to the machining location (1-channel system) or compressed air and MQL medium are conveyed separately to the mixing chamber where they are then mixed together (2-channel system).

The aerosol feed to the machining location is achieved via a suitable minimal quantity lubrication rotary adaptor (preferably with axial flowthrough), the spindle, the clamping system and finally the cutting tool. Unavoidable cross-section modifications should be as streamlined as possible.

1-channel MQL system

With a 1-channel MQL system, a lubricating aerosol is created in a separate MQL unit attached to the machine tool. Special nozzle systems inside a pressurised container create a lubricating aerosol via a regulated compressed air feed, its neat oil content adjustable and then maintained within the physical limits by the MQL control.

With a 1-channel MQL system, a lubricating aerosol is created in a separate MQL unit attached to the machine tool. Special nozzle systems inside a pressurised container create a lubricating aerosol via a regulated compressed air feed, its neat oil content adjustable and then maintained within the physical limits by the MQL control.

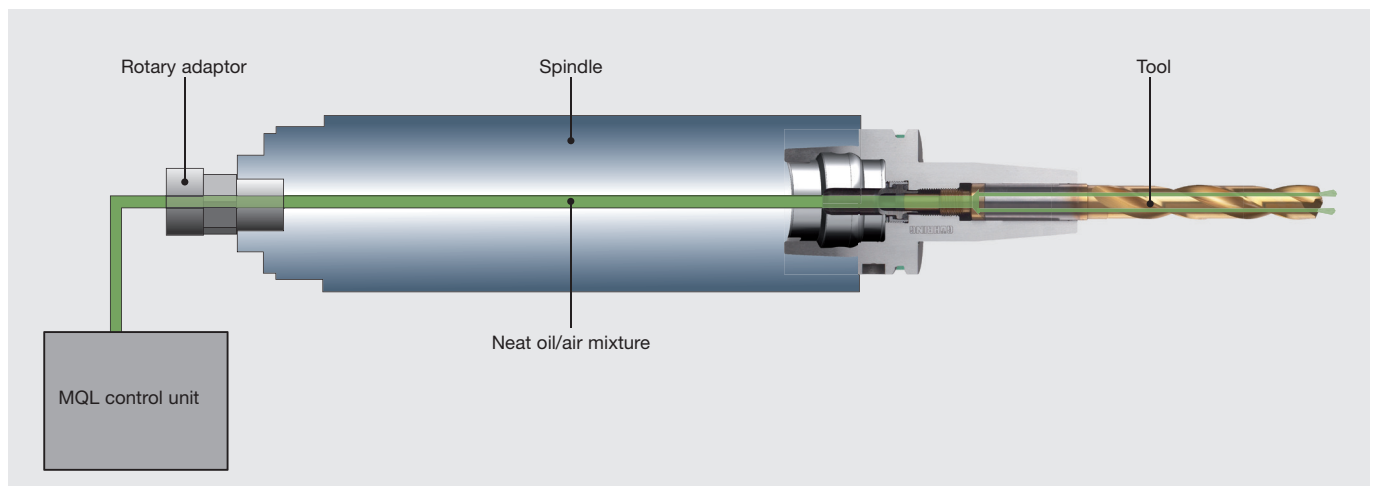

The 2-channel MQL system

With a 2-channel system the neat oil reaches the rotary adaptor from the unit via a ring line and a as short as possible stub line. In it is incorporated a quick valve that regulates minute quantities of neat oil. The neat oil is transported into the tool holder via a lance attached in the spindle. The second channel of the rotary adaptor is used for the air supply to the tool holder. Only at this point the air is mixed with the neat oil.

To achieve this, the tool holder possesses a pressed-in pipe nozzle in which the mixing chamber is located. Neat oil and air can be mixed with this system in more or less any quantities. The route from the mixing chamber to the point of destination is only minimal resulting in a rapid response time and allowing a very quick alteration of the volume of neat oil.

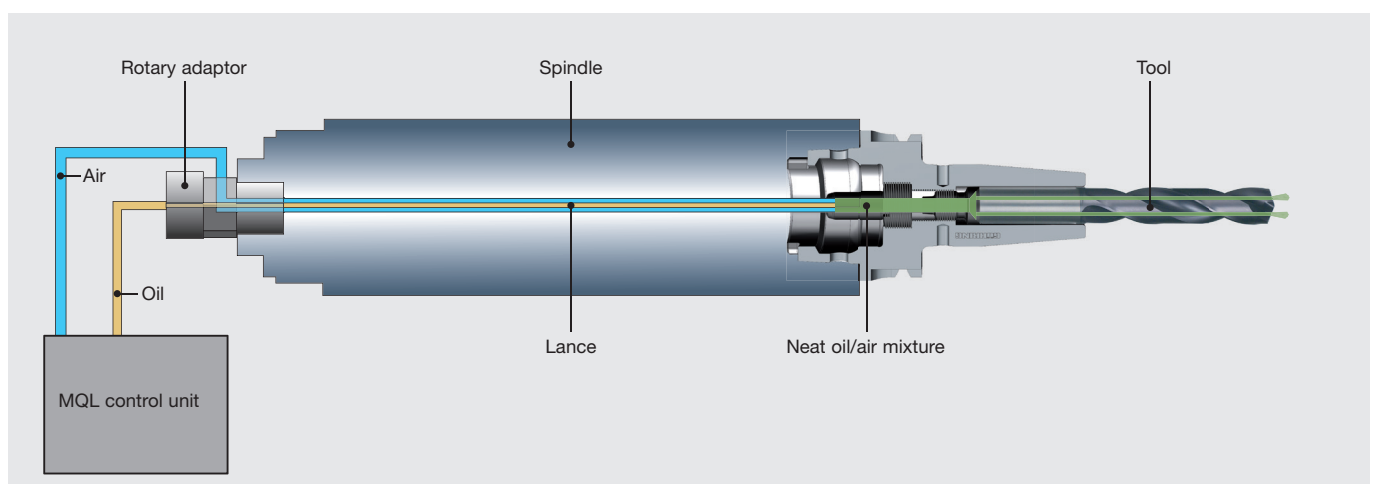

INSTALLATION INSTRUCTIONS

1. The HSK holder must be clean, free of swarf and undamaged.
2. Grease the O-rings prior to assembly.
3. Centrally insert the complete coolant delivery set (coolant pipe, union nut and 2 O-rings) in the HSK with the assistance of the socket spanner. When inserting the MQL coolant delivery unit, it is paramount to ensure that the MQL pipe is inserted centrally and undamaged into the MQL length setting screw (do not kink).
4. Screw in the coolant delivery set/coolant delivery unit and tighten (see table for torque figures)
5. Check coolant pipe for radial mobility.

Torque figures

for HSK	MA Nm
32	7
40	11
50	15
63	20
80	25
100	30

Installation of MQL coolant delivery set 4939

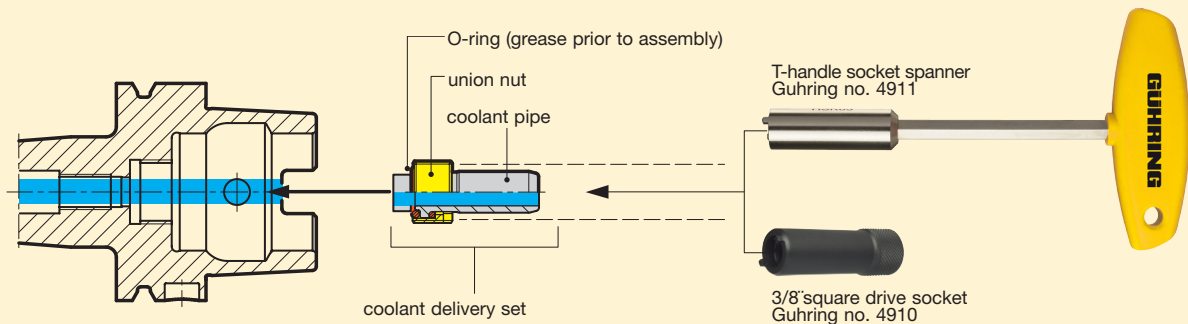

Installation of MQL coolant delivery set filler 4940

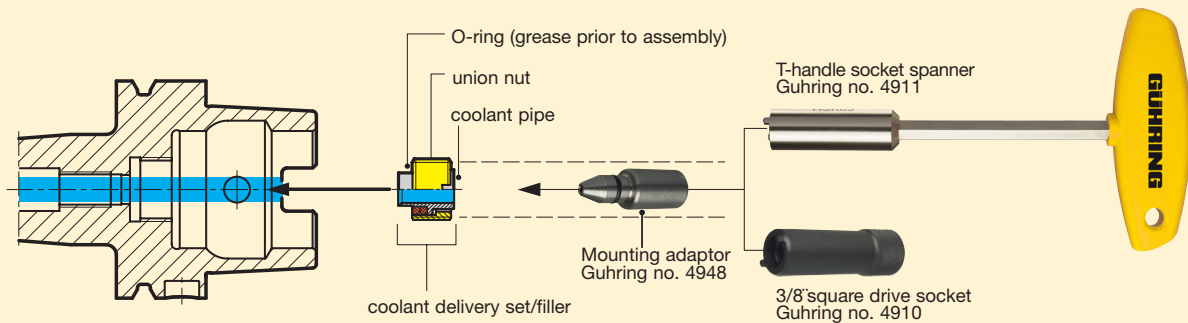

Installation of MQL coolant delivery unit 4623/4924

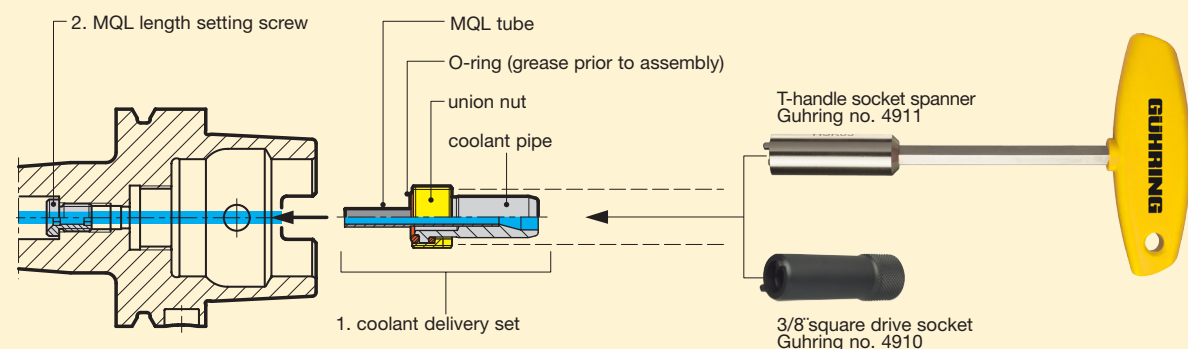

GUHRING NO. INDEX

Guhring no.	Tool	Page
4050	MQL-Key 3000	15
4209	MQL 1-channel hydraulic chucks HSK-A for manual tool change	8
4210	MQL 1-channel hydraulic chucks HSK-A for automatic tool change	9
4298	MQL synchro tapping chucks HSK-A for manual tool change	19/35
4305	MQL setting screws with internal taper for synchro chucks	36
4330	MQL 1-channel synchro tapping chucks HSK-A for automatic tool change	19
4341	MQL 2-channel synchro tapping chucks HSK-A for automatic tool change	35
4350	Extensions HSK-A/HSK-C with MQL 4-point clamping set	17
4611	MQL 2-channel hydraulic chucks HSK-A for manual tool change	21
4612	MQL 2-channel hydraulic chucks HSK-A for automatic tool change	22
4613	MQL 2-channel shrink fit chucks HSK-A for manual tool change	24
4614	MQL 2-channel shrink fit chucks HSK-A for automatic tool change	27
4615	M contour clamping sets for MQL and IC	45
4616	Assembly / disassembly tool for M contour clamping sets	46
4617	Sealing lip for MMS 1-channel length setting screws	15
4621	MQL 2-channel length setting screws for HSK-A	30
4622	MQL 2-channel coolant delivery set HSK-A (filler)	32
4623	MQL 2-channel coolant delivery set HSK-A	33
4624	Assembly / disassembly tool for M contour clamping sets	46
4735	MQL 1-channel shrink fit chucks HSK-A for manual tool change	10
4741	MQL 1-channel shrink fit chucks HSK-A for automatic tool change	12
4930	GÜHROCLAMP MQL 4-point clamping sets for MQL and IC	43
4931	GÜHROCLAMP Spindle with clamping jaws	43
4932	GÜHROCLAMP Ejector with tube	43
4933	Retention spindles for GÜHROCLAMP MQL 4-point clamping sets	44
4934	Adaptor for GÜHROCLAMP MQL 4-point clamping sets	44
4935	Retention screw for GÜHROCLAMP MQL 4-point clamping sets	45
4937	MQL 1-channel length setting screws for HSK-A	14
4939	MQL 1-channel coolant delivery set HSK-A	16
4940	MQL 1-channel coolant delivery set HSK-A (filler)	16
4941	Length adjustment screw for conventional cooling	18
4948	Mounting adaptor for MQL HSK-A coolant delivery sets HSK-A (filler)	17
	MQL-Check 3000	47

MQL - PERFORMANCE TEST

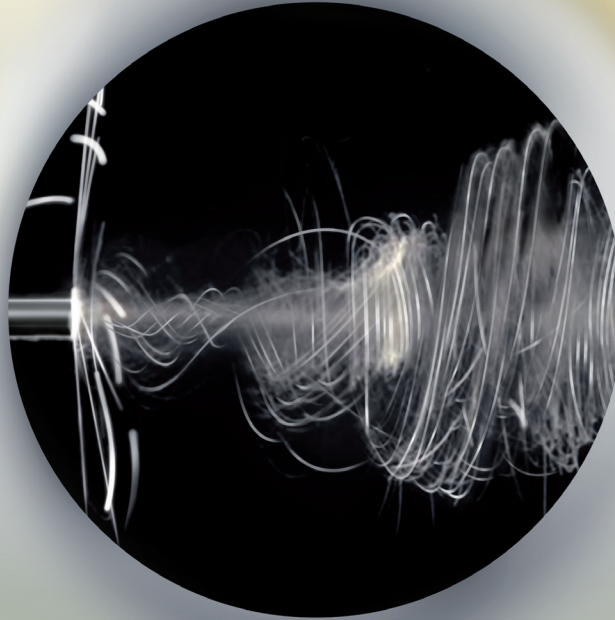

MQL
BY GÜHRING

RESEARCH & DEVELOPMENT

MADE VISIBLE

In Guhring's R&D department the MQL spray pattern of a tool can be made visible under the most diverse application conditions such as MQL 1- or 2-channel system, pressure and speed with the help of a test facility as well as a high speed camera always giving you the assurance that your MQL supply operates perfectly.

Guhring KG

Herderstraße 50 - 54 | 72458 Albstadt
Tel.: +49 74 31 17 - 0 | Fax: +49 74 31 17 - 21 279
info@guehring.de | www.guehring.de